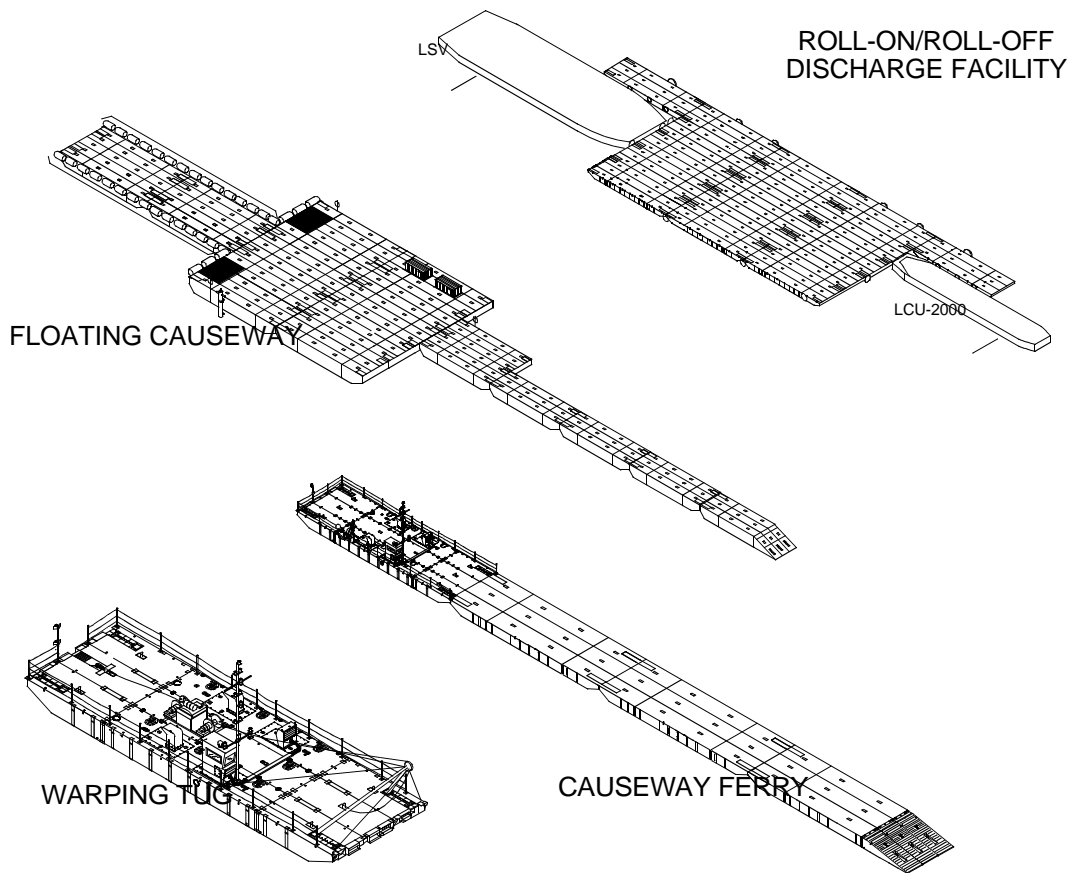


TM 55-1945-205-10-1

TECHNICAL MANUAL OPERATORS MANUAL FOR

MODULAR CAUSEWAY SYSTEM (MCS) CAUSEWAY FERRY (CF) CF-1 NSN 1945-01-398-3856



This manual supersedes TM 55-1945-205-10 dated 29 August 1997, including all changes.

DISTRIBUTION STATEMENT A - Approved for public release; distribution is unlimited.

HEADQUARTERS, DEPARTMENT OF THE ARMY

SEPTEMBER 2003

WARNING SUMMARY

NO SMOKING

Smoking is prohibited aboard this vessel.

JEWELRY

Remove rings, bracelets, wristwatches, and neck chains before working around or on a unit.

HEAVY OBJECTS

Handling heavily weighted objects can cause bodily injury. Do not lift materials or equipment over 50 lbs without using appropriate material handling equipment.

BATTERIES

Do not smoke around batteries. Personnel must wear goggles and chemical resistant gloves when adding electrolyte and cleaning up spills.

HAZARD REPORTING

Report all hazards. It is your responsibility to report hazards through your chain-of-command.

HIGH VOLTAGE

Use extreme caution when checking energized circuits. Always place power off warning tags on power supply switches so that no one will apply power while performing maintenance.

HAZARDOUS FUMES IN CONFINED SPACES

The lazaret, engine, fuel and storage compartments are confined spaces and may contain hazardous fumes. Refer to FM 55-502 before entering a confined space. Never enter a confined space before checking the confined space with a gas free meter. Operate the exhaust plenum ventilation fan to remove fumes.

NUCLEAR, BIOLOGICAL OR CHEMICAL

In the event equipment has been exposed to nuclear, biological or chemical warfare, the equipment shall be handled with extreme caution and decontaminated in accordance with FM 3-5, instructions for immediate, operational and thorough decon procedures adapted for the marine environment. Unprotected personnel can experience injury or death if residual toxic agents or radioactive material are present. If equipment is exposed to radioactive, biological or chemical agents, personnel must wear protective mask, hood, protective overgarments, chemical gloves and chemical boots in accordance with MOPP - level prescribed by the OIC or NCOIC.

FUELS

Personnel must wear chemical resistant gloves when handling fuels. Promptly wash exposed skin and change fuel-soaked clothing.

COOLANTS

Before opening coolant system, allow time to cool and wear effective hand, eye and skin protection.

ICE BUILDUP

Cold weather operations could create ice buildup on exposed surfaces producing hazardous footing conditions. Use extreme care when operating under icing conditions; death or serious injury to personnel could occur.

SAFETY WARNING ICONS



ELECTRICAL

ELECTRICAL - Electrical wire to hand with electricity symbol running through hand shows that shock hazard is present.



ELECTRICAL

ELECTRICAL 2- Electrical wire to arm with electricity symbol running through hand shows that shock hazard is present.



EYE PROTECTION

EYE PROTECTION - Person with goggles shows that the material will injure the eyes.



HEAVY OBJECTS

HEAVY OBJECTS - Human figure stooping over heavy object shows physical injury potential from improper lifting technique.



HEAVY PARTS

HEAVY PARTS - Foot with heavy object on top shows that heavy parts can crush and harm.



HEAVY PARTS

HEAVY PARTS 3 - Heavy object on human figure shows that heavy parts present a danger to life or limb.



HELMET PROTECTION

HELMET - Arrow bouncing off head with helmet shows that falling parts present a danger.



HOT AREA

HOT AREA - Hand over object radiating heat shows that part is hot and can burn.



MOVING PARTS

MOVING PARTS 2 - Hand with fingers caught between gears shows that the moving parts of the equipment present a danger to life or limb.



VEST

VEST - Life preserver on human figure shows life preserver must be worn to prevent drowning.

HAZARDOUS MATERIAL WARNING ICONS



CHEMICAL

CHEMICALS - Drops of liquid on hand shows that the material will cause burns or irritation to human skin or tissue.



EXPLOSION

EXPLOSION - Rapidly expanding symbol shows that the material may explode if subjected to high temperatures, sources of ignition or high pressure.



FIRE

FIRE - Flame shows that a material may ignite and cause burns.



POISON

POISON - Skull and crossbones shows that a material is poisonous or is a danger to life.



VAPOR

VAPOR - Human figure in a cloud shows that material vapors present a danger to life or health.

TECHNICAL MANUAL
OPERATORS MAINTENANCE MANUAL
FOR
MODULAR CAUSEWAY SYSTEM (MCS)
CAUSEWAY FERRY (CF)
CF-1
NSN 1945-01-398-3856

DISTRIBUTION STATEMENT A - Approved for public release; distribution is unlimited.

TM 55-1945-205-10-1, 13 September 2003, is updated as follows:

1. File this sheet in front of the manual for reference.
2. The portion of text affected by the changes is indicated by a vertical line in the outer margins of the page.
3. Changes to illustrations are indicated by a vertical line and/or miniature pointing hand adjacent to the changed area.
4. When tables are updated or added, the change bar shall also be placed to the left of the table number and title.
5. Remove old pages and insert new pages as indicated below:

Remove Pages

a and b
A and B
Title Block Page
i through iv
INDEX-1 through INDEX-6
Back Cover

Insert Pages

a through d
A and B
Title Block Page
i through iv
INDEX-1 through INDEX-8
Back Cover

6. Replace the following work packages with their revised version:

Work Package Number

WP 0001 00
WP 0002 00
WP 0003 00
WP 0004 00
WP 0005 00
WP 0006 00
WP 0007 00
WP 0010 00
WP 0011 00
WP 0012 00
WP 0013 00
WP 0014 00

6. Replace the following work packages with their revised version: (Cont'd)

Work Package Number (Cont'd)

WP 0016 00
WP 0017 00
WP 0018 00
WP 0020 00
WP 0035 00
WP 0036 00
WP 0037 00
WP 0039 00
WP 0041 00
WP 0042 00
WP 0044 00
WP 0045 00
WP 0046 00
WP 0047 00
WP 0048 00
WP 0049 00
WP 0052 00
WP 0061 00
WP 0084 00
WP 0085 00
WP 0100 00
WP 0101 00
WP 0102 00
WP 0103 00
WP 0104 00
WP 0105 00
WP 0106 00
WP 0107 00

7. Add the following new work packages:

Work Package Number

WP 0013 10
WP 0013 20
WP 0016 10
WP 0016 20
WP 0019 10
WP 0019 20
WP 0034 10
WP 0034 20
WP 0035 10
WP 0035 20
WP 0038 10
WP 0040 10
WP 0041 10
WP 0042 10
WP 0049 10

7. Add the following new work packages: (Cont'd)

Work Package Number

WP 0050 10

WP 0050 20

WP 0060 10

WP 0060 20

WP 0060 30

WP 0085 10

WP 0085 20

WP 0085 30

WP 0098 10

WP 0098 20

By Order of the Secretary of the Army:

PETER J. SCHOOMAKER
General, United States Army
Chief of Staff

Official:



SANDRA R. RILEY

*Administrative Assistant to the
Secretary of the Army*

0518114

DISTRIBUTION: To be distributed in accordance with the Initial Distribution Number (IDN) 256440 requirements for TM 55-1945-205-10-1.

INSERT LATEST CHANGED PAGE/WORK PACKAGES. DESTROY SUPERSEDED DATA.

LIST OF EFFECTIVE PAGES / WORK PACKAGES

Dates of issue for original and changed pages / work packages are:

NOTE: The portion of text affected by the changes is indicated by a vertical line in the outer margins of the page. Changes to illustrations are indicated by a vertical line and/or miniature pointing hand adjacent to the changed area. When tables are updated or added, the change bar shall also be placed to the left of the table number and title.

Original 13 SEP 03
 Change 1 15 AUG 05

TOTAL NUMBER OF PAGES FOR FRONT AND REAR MATTER IS 40 AND TOTAL NUMBER OF WORK PACKAGES IS 107 CONSISTING OF THE FOLLOWING:

Page / WP No.	*Change No.	Page / WP No.	*Change No.
Front Cover (2 pgs)	0	WP 0019 20 (8 pgs)	1
Warning Summary (a-d pgs)	1	WP 0020 00 (10 pgs)	1
Change Sheet Transmittal (4 pgs)	1	WP 0021 00 (10 pgs)	0
List of Effective Pages (A and B pgs)	1	WP 0022 00 (2 pgs)	0
Title Block Page (2 pgs)	1	WP 0023 00 (6 pgs)	0
Table of Contents (i-iv pgs)	1	WP 0024 00 (2 pgs)	0
How to Use This Manual (v-viii pgs)	0	WP 0025 00 (4 pgs)	0
WP 0001 00 (4 pgs)	1	WP 0026 00 (16 pgs)	0
Chp 1 title page	0	WP 0027 00 (12 pgs)	0
WP 0002 00 (2 pgs)	1	WP 0028 00 (22 pgs)	0
WP 0003 00 (20 pgs)	1	WP 0029 00 (8 pgs)	0
WP 0004 00 (4 pgs)	1	WP 0030 00 (6 pgs)	0
WP 0005 00 (16 pgs)	1	WP 0031 00 (6 pgs)	0
Chp 2 title page	0	WP 0032 00 (4 pgs)	0
WP 0006 00 (44 pgs)	1	WP 0033 00 (2 pgs)	0
WP 0007 00 (12 pgs)	1	WP 0034 00 (4 pgs)	0
WP 0008 00 (4 pgs)	0	WP 0034 10 (2 pgs)	1
WP 0009 00 (2 pgs)	0	WP 0034 20 (6 pgs)	1
WP 0010 00 (4 pgs)	1	WP 0034 30 (2 pgs)	1
WP 0011 00 (4 pgs)	1	WP 0035 00 (4 pgs)	1
WP 0012 00 (4 pgs)	1	WP 0035 10 (2 pgs)	1
WP 0013 00 (4 pgs)	1	WP 0035 20 (6 pgs)	1
WP 0013 10 (2 pgs)	1	WP 0036 00 (6 pgs)	1
WP 0013 20 (2 pgs)	1	WP 0037 00 (4 pgs)	1
WP 0014 00 (28 pgs)	1	WP 0038 00 (4 pgs)	0
WP 0015 00 (2 pgs)	0	WP 0038 10 (4 pgs)	1
WP 0016 00 (4 pgs)	1	WP 0039 00 (4 pgs)	1
WP 0016 10 (4 pgs)	1	WP 0040 00 (2 pgs)	0
WP 0016 20 (2 pgs)	1	WP 0040 10 (2 pgs)	1
WP 0017 00 (6 pgs)	1	WP 0041 00 (28 pgs)	1
WP 0018 00 (8 pgs)	1	WP 0041 10 (2 pgs)	1
WP 0019 00 (4 pgs)	0	WP 0042 00 (4 pgs)	1
WP 0019 10 (2 pgs)	1	WP 0042 10 (2 pgs)	1

TM 55-1945-205-10-1

Page / WP No.	*Change No.	Page / WP No.	*Change No.
WP 0043 00 (4 pgs)	0	WP 0083 00 (2 pgs)	0
WP 0044 00 (4 pgs)	1	WP 0084 00 (2 pgs)	1
WP 0045 00 (4 pgs)	1	WP 0085 00 (2 pgs)	1
WP 0046 00 (4 pgs)	1	WP 0085 10 (2 pgs)	1
WP 0047 00 (4 pgs)	1	WP 0085 20 (2 pgs)	1
WP 0048 00 (2 pgs)	1	WP 0085 30 (2 pgs)	1
WP 0049 00 (12 pgs)	1	WP 0086 00 (2 pgs)	0
WP 0049 10 (2 pgs)	1	WP 0087 00 (2 pgs)	0
WP 0050 00 (2 pgs)	0	WP 0088 00 (2 pgs)	0
WP 0050 10 (2 pgs)	1	WP 0089 00 (2 pgs)	0
WP 0050 20 (4 pgs)	1	WP 0090 00 (2 pgs)	0
WP 0051 00 (2 pgs)	0	WP 0091 00 (2 pgs)	0
WP 0052 00 (4 pgs)	1	WP 0092 00 (2 pgs)	0
WP 0053 00 (4 pgs)	0	WP 0093 00 (2 pgs)	0
WP 0054 00 (2 pgs)	0	WP 0094 00 (2 pgs)	0
WP 0055 00 (2 pgs)	0	WP 0095 00 (2 pgs)	0
WP 0056 00 (4 pgs)	0	WP 0096 00 (2 pgs)	0
WP 0057 00 (6 pgs)	0	WP 0097 00 (2 pgs)	0
WP 0058 00 (2 pgs)	0	WP 0098 00 (2 pgs)	0
WP 0059 00 (2 pgs)	0	WP 0098 10 (2 pgs)	1
WP 0060 00 (6 pgs)	0	WP 0098 20 (2 pgs)	1
WP 0060 10 (4 pgs)	1	Chp 4 title page	0
WP 0060 20 (6 pgs)	1	WP 0099 00 (4 pgs)	0
WP 0060 30 (4 pgs)	1	WP 0100 00 (82 pgs)	1
Chp 3 title page	0	Chp 5 title page	0
WP 0061 00 (4 pgs)	1	WP 0101 00 (2 pgs)	1
WP 0062 00 (2 pgs)	0	WP 0102 00 (4 pgs)	1
WP 0063 00 (2 pgs)	0	WP 0103 00 (74 pgs)	1
WP 0064 00 (2 pgs)	0	WP 0104 00 (6 pgs)	1
WP 0065 00 (2 pgs)	0	WP 0105 00 (12 pgs)	1
WP 0066 00 (2 pgs)	0	WP 0106 00 (4 pgs)	1
WP 0067 00 (2 pgs)	0	WP 0107 00 (2 pgs)	1
WP 0068 00 (2 pgs)	0	Index-1 - Index-8 (8 pgs)	1
WP 0069 00 (2 pgs)	0	DA Form 2028 (4 pgs)	0
WP 0070 00 (2 pgs)	0	Authentication Page (2 pgs)	0
WP 0071 00 (2 pgs)	0	Back Cover (2 pgs)	1
WP 0072 00 (2 pgs)	0		
WP 0073 00 (2 pgs)	0		
WP 0074 00 (2 pgs)	0		
WP 0075 00 (2 pgs)	0		
WP 0076 00 (2 pgs)	0		
WP 0077 00 (2 pgs)	0		
WP 0078 00 (2 pgs)	0		
WP 0079 00 (2 pgs)	0		
WP 0080 00 (2 pgs)	0		
WP 0081 00 (2 pgs)	0		
WP 0082 00 (2 pgs)	0		

* Zero in this column indicates an original page.

TECHNICAL MANUAL

**OPERATORS MANUAL
FOR**

**MODULAR CAUSEWAY SYSTEM (MCS)
CAUSEWAY FERRY (CF)
CF-1
NSN 1945-01-398-3856**

This manual supersedes TM 55-1945-205-10 dated 29 August 1997, including all changes.

REPORTING ERRORS AND RECOMMENDING IMPROVEMENTS

You can help improve this publication. If you find any mistakes or if you know of a way to improve the procedures, please let us know. Submit your DA Form 2028 (Recommended Changes to Equipment Technical Publications), through the Internet, on the Army Electronic Product Support (AEPS) website. The Internet address is <http://aeeps.ria.army.mil>. If you need a password, scroll down and click on "ACCESS REQUEST FORM". The DA Form 2028 is located in the ONLINE FORMS PROCESSING section of the AEPS. Fill out the form and click on SUBMIT. Using this form on the AEPS will enable us to respond quicker to your comments and better manage the DA Form 2028 program. You may also mail, fax or email your letter or DA Form 2028 direct to: AMSTA-LC-CI / TECH PUBS, TACOM-RI, 1 Rock Island Arsenal, Rock Island, IL 61299-7630. The email address is TACOM-TECH-PUBS@ria.army.mil. The fax number is DSN 793-0726 or Commercial (309) 782-0726.

DISTRIBUTION STATEMENT A - Approved for public release; distribution is unlimited.

TABLE OF CONTENTS

WP Sequence No.

WARNING SUMMARY

HOW TO USE THIS MANUAL

General Information 0001 00

CHAPTER 1 - DESCRIPTION AND THEORY OF OPERATION

Description and Data, Equipment Characteristics, Capabilities and Features 0002 00
 Description and Data, Location and Description of Major Components 0003 00
 Description and Data, Equipment Data 0004 00
 Theory of Operation 0005 00

CHAPTER 2 - OPERATOR INSTRUCTIONS

Operator Controls and Indicators, Description and Use 0006 00
 Module ISOPAK, Preparation For Use 0007 00
 Male and Female Guillotine Connectors, Preparation For Use 0008 00
 D-Ring/Cloverleaf and Deck Cleat Fittings, Preparation For Use 0009 00
 Module Strings, Preparation For Use 0010 00
 Intermediate Section, Preparation For Use 0011 00
 Beach End Section, Preparation For Use 0012 00
 Powered Section On Deck, Preparation For Use 0013 00
 Powered Section In Water, Preparation For Use 0013 10
 Stabilizers, Preparation For Use 0013 20
 Above Deck Equipment, Preparation For Use 0014 00
 Anchorboard Assembly, Preparation For Use 0015 00
 Stub Navigation Mast, Preparation For Use 0016 00
 Bow Stub Mast, Preparation For Use 0016 10
 Main Mast Deck Floodlight, Preparation For Use 0016 20
 Fenders, Preparation For Use 0017 00
 Safety Equipment, Preparation For Use 0018 00
 Causeway Ferry, Preparation For Use 0019 00
 Deck Box, Preparation For Use 0019 10
 Crew Shelter, Preparation For Use 0019 20
 Causeway Ferry, Operating Procedures 0020 00
 VHF/FM Handheld Transceiver, Operating Procedures 0021 00
 Interface and Switchbox, Operating Procedures 0022 00
 Public Address Set (Loudhailer), Operating Procedures 0023 00
 SINCGARS Radio, Operating Procedures 0024 00
 VHF/FM DSC Transceiver, Perform Initial Setup, Operating Procedures 0025 00
 VHF/FM DSC Transceiver, Operating Procedures 0026 00
 VHF/FM DSC Transceiver, Perform User Setups, Operating Procedures 0027 00
 VHF/FM DSC Transceiver, DSC Functions, Operating Procedures 0028 00
 Precision Lightweight Global Positioning Receiver (PLGR), Perform Initial Setup,
 Operating Procedures 0029 00

TABLE OF CONTENTS (CONT'D)

WP Sequence No.

CHAPTER 2 - OPERATOR INSTRUCTIONS (CONT'D)

Precision Lightweight Global Positioning Receiver (PLGR), Setup Waypoints,
 Operating Procedures 0030 00

Precision Lightweight Global Positioning Receiver (PLGR), Setup Route Navigation,
 Operating Procedures 0031 00

Precision Lightweight Global Positioning Receiver (PLGR), Perform Crypto Variable
 Operations, Operating Procedures 0032 00

DC To DC Converter, Operating Procedures 0033 00

Anchor Deployment and Recovery, Operating Procedures 0034 00

Battery Selector Switch, Operating Procedures 0034 10

Chart (Map) Light, Operating Procedures 0034 20

Decals and Instruction Plates Location 0035 00

Deck Box, Preparation For Movement 0035 10

Crew Shelter, Preparation For Movement 0035 20

Safety Equipment, Preparation For Movement 0036 00

Fenders, Preparation For Movement 0037 00

D-Ring/Cloverleaf and Deck Cleat Fittings, Preparation For Movement 0038 00

Bow Mast, Preparation For Movement 0038 10

Stub Navigation Mast, Preparation For Movement 0039 00

Anchorboard Assembly, Preparation For Movement 0040 00

Main Mast Deck Floodlight, Preparation For Movement 0040 10

Above Deck Equipment, Preparation For Stowage or Shipment 0041 00

Stabilizers, Preparation For Movement 0041 10

Powered Section On Deck, Preparation For Movement 0042 00

Powered Section In Water, Preparation For Movement 0042 10

Causeway Ferry, Preparation For Movement 0043 00

Beach End Section, Preparation For Movement 0044 00

Intermediate Section, Preparation For Movement 0045 00

Module Strings, Preparation For Movement 0046 00

Male and Female Guillotine Connectors, Preparation For Movement 0047 00

Flexor Connectors, Preparation For Movement (Deleted) 0048 00

Module ISOPAK, Preparation For Movement 0049 00

Nuclear, Biological Or Chemical Decontamination, Unusual 0049 10

Environment/Weather, Unusual 0050 00

Starting Engine, Emergency Procedure 0050 10

Emergency Starting Procedures, Slaving the Causeway Ferry, Emergency Procedure 0050 20

Diesel Engine, Emergency Procedure 0051 00

Fire Suppression System, Manually Operate, Emergency Procedure 0052 00

Steering System, Emergency Steering, Emergency Procedure 0053 00

Steering System, Emergency Engagement of Marine Gear, Emergency Procedure 0054 00

Precision Lightweight Global Positioning Receiver (PLGR), Mark Position of Man
 Overboard, Emergency Procedure 0055 00

VHF/FM DSC Transceiver, Send Distress, Emergency Procedure 0056 00

VHF/FM DSC Transceiver, Receiving a Distress, Emergency Procedure 0057 00

VHF/FM DSC Transceiver, Cancel Distress, Emergency Procedure 0058 00

Public Address Set (Loudhailer), Emergency Procedure 0059 00

TABLE OF CONTENTS (CONT'D)

WP Sequence No.

CHAPTER 2 - OPERATOR INSTRUCTIONS (CONT'D)

Basic Issue Items (BII) and Equipment, Stowage	0060 00
Side Fenders, Stowage.....	0060 10
Pilothouse (Operators Cab), Stowage.....	0060 20
Stowage, Anchorboard and Ship Fendering	0060 30

CHAPTER 3 - OPERATOR TROUBLESHOOTING PROCEDURES

Troubleshooting Procedures Index	0061 00
Exhaust Plenum Ventilation Fan Will Not Operate	0062 00
Diesel Engine Has a Sudden Loss of Power (Heavy Black Smoke)	0063 00
Diesel Engine Will Turn Over, But Will Not Start	0064 00
Diesel Engine Fails to Start, Starts With Difficulty and Runs Badly	0065 00
Diesel Engine Will Not Turn Over	0066 00
Diesel Engine Starts With Difficulty and Runs Rough	0067 00
Diesel Engine Has a Sudden Loss Of Power (No Black Smoke)	0068 00
Diesel Engine Audible Alarm and Warning Light On (Normal Operation)	0069 00
Diesel Engine Oil Pressure Gauge Reads Above 70 PSI (Normal Operation)	0070 00
Diesel Engine Overheating (Audible Alarm and Warning Light On)	0071 00
Drive Train Does Not Operate Freely and Smoothly, Excessive Vibration Is Experienced	
During Operation	0072 00
Marine Gear Clutch Will Not Engage In Engage/Backflush Directions	0073 00
Marine Gear Clutch Status Light, Not Operational	0074 00
Hydraulic System Has No Pressure	0075 00
No Propulsion From Pump-Jet	0076 00
Pump-Jet Can Only Develop a Small Amount of Thrust (Not Enough Water	
Being Delivered)	0077 00
No Steering Control From the Pump-Jet	0078 00
Pump-Jet Steering Reacts Sluggishly	0079 00
Steering System, No Steering From Operators Cab	0080 00
Pump-Jet, No Steering Control Indication	0081 00
Diesel Engine, Ammeter Indicates Discharging of System	0082 00
Bilge Pump(s) Will Not Function	0083 00
No Power To Operators Cab Control Panels	0084 00
Operators Cab Accessories Do Not Function	0085 00
Operators Cab Defroster Does Not Operate (No Fan and No Heat)	0085 10
Heater Does Not Operate.....	0085 20
All Circuits Controlled By 3A3CB1 - 3A3CB10 Are Not Functioning	0085 30
Public Address Set (Loudhailer) Has No Power	0086 00
Public Address Set (Loudhailer) Will Not Transmit Voice To Hailer Horn	
(Loudhailer External Speaker)	0087 00
Public Address Set (Loudhailer) Will Not Transmit Fog Signal To (Loudhailer	
External Speaker)	0088 00
Public Address Set (Loudhailer) Will Not Transmit VHF/FM DSC Transceiver Audio	
To Hailer Horn (Loudhailer External Speaker)	0089 00
VHF/FM DSC Transceiver Has No Power	0090 00
VHF/FM DSC Transceiver Will Not Receive	0091 00
VHF/FM DSC Transceiver Will Not Transmit	0092 00
VHF/FM DSC Transceiver Does Not Display a Valid Position	0093 00

TABLE OF CONTENTS (CONT'D)

WP Sequence No.

CHAPTER 3 - OPERATOR TROUBLESHOOTING PROCEDURES (CONT'D)

Precision Lightweight Global Positioning Receiver (PLGR) Has No Power 0094 00
 Precision Lightweight Global Positioning Receiver (PLGR) Does Not Display a Valid
 Valid Position 0095 00
 Precision Lightweight Global Positioning Receiver (PLGR) Has Cleared Memory 0096 00
 Navigation Lights, Audible Pulse Beeper Sounds 0097 00
 Navigation Lights Will Not Function 0098 00
 Bow Light Will Not Function..... 0098 10
 Main Mast Deck Floodlights Will Not Function..... 0098 20

CHAPTER 4 - OPERATOR MAINTENANCE INSTRUCTIONS

Preventive Maintenance Checks and Services (PMCS), Procedures Introduction 0099 00
 Preventive Maintenance Checks and Services (PMCS) and Lubrication Procedures 0100 00

CHAPTER 5 - OPERATOR SUPPORTING INFORMATION

References 0101 00
 Maintenance Allocation Chart (MAC), Introduction 0102 00
 Maintenance Allocation Chart (MAC) 0103 00
 Components of End Item (COEI) List 0104 00
 Basic Issue Items (BII) List 0105 00
 Expendable and Durable Items List (EDIL) 0106 00
 Tool Identification List (TIL) 0107 00

INDEX

Alphabetical.....INDEX - 1

HOW TO USE THIS MANUAL

This manual contains certain features to improve the convenience of using this manual and increase the user's efficiency. These features include:

a. Accessing Information

Information is accessed by referring to the Table of Contents, located in the front of this manual or by looking in the Alphabetical Index, located in the back of this manual.

b. Illustrations

Various methods are used to locate and repair components. Locator illustrations in Controls and Indicator tables, PMCS tables, exploded views and cut-away diagrams make the information in the manual easier to understand and follow.

c. Using This Manual

When using this manual, read and understand the entire maintenance action before performing the task. Also, read and understand all warnings, cautions and notes as well as general safety precautions that apply to the task to be performed. The warning summary will inform personnel of hazards associated with the equipment to be worked on. However, the summary is not all inclusive and personnel should be aware at all times of hazardous conditions that may arise.

Prior to starting the procedures in this manual, the initial setup requirements are located directly above each procedure. The information is given to ensure all materials, expendables, tools and any other equipment necessary are readily available for use. The initial setup will be accomplished prior to starting the actual steps of each maintenance procedure.

Locating Major Components

Obtain the manual for the system to be worked on. Open to the Table of Contents located in the front of this manual. Find Chapter 1, *Description and Theory of Operation*. Under the chapter title you will find the work package titled *Location and Description of Major Components*. Turn to the work package indicated. This work package will give a brief description of the major components and show an illustration of what the component looks like and its location.

The Alphabetical Index, located in the back of this manual contains an alphabetical list of all sections of this manual. *Location and Description of Major Components* is found in section L. The work package is found on the right side of the title where the *Location and Description of Major Components* is located. Turn to the work package indicated to find the description and location of each component.

Operator Instructions

To locate an operator task, open the manual to the Table of Contents located in the front of this manual. Locate the procedure that is to be performed. Next to the procedure, on the right, locate the work package number. Turn to the work package number in the manual. Perform the initial setup by obtaining the expendables, tools, materials and other items listed prior to starting the task. Perform the listed steps in order. The Alphabetical Index can also be used to locate the item and procedures to follow.

Tools: Lists all tools (standard or special) required to perform the task. Tools are identified with an item number and work package number from the *Tool Identification List* located in Chapter 4, *Supporting Information*.

Materials/Parts: Lists all parts or materials necessary to perform the task. Expendables and durables are identified with an item number from the applicable work package located in Chapter 4, *Supporting Information*.

Personnel Required: Lists all personnel necessary to perform the task.

Equipment Condition: Notes the conditions that must exist before starting the task. The equipment condition will also include any prerequisite maintenance tasks to be performed with reference to the work package number or to the TM number.

References: Includes any other manuals necessary to complete the task. When there are no references listed, all steps necessary to complete the task are contained within this manual. A listing of reference materials is contained in the work package *References* in Chapter 4, *Supporting Information*.

Location of Controls and Indicators

To locate a particular control and/or indicator, open the manual to the Table of Contents located in the front of the manual. Find Chapter 2, *Operator Instructions*. Locate the work package titled *Description and Use of Operator Controls and Indicators*. Turn to the work package indicated. Locate the control and/or indicator that you are attempting to identify. Take note of the number pointing to the control or indicator. Refer to the table below the picture and find the number in the column on the far left hand side. Reading from left to right, find the number that matches the number from the picture, then read the name of the control/indicator and following function of the item, as detailed in the far right hand column.

Troubleshooting Procedures

The Table of Contents or Alphabetical Index may be used to locate sections within this manual. To locate a particular troubleshooting procedure, open the manual to the Table of Contents located in the front of this manual. Find Chapter 3, *Troubleshooting Procedures*. Under this section, find a work package titled *Troubleshooting Index*. Turn to the work package indicated, which lists all of the troubleshooting procedures. Look down the list until you find the appropriate work package for the problem you are trying to solve. To the right side of the procedure will be a work package number. Turn to the work package indicated and follow the steps to complete the troubleshooting procedure. The procedures list the malfunction, symptom and the corrective action. The corrective action will indicate which maintenance procedure to go to for the repair of the symptom or what level of maintenance is capable of repairing the problem. Follow the procedures indicated to complete the task. At the top of the task you will have a section called INITIAL SETUP. There are five basic headings listed under INITIAL SETUP.

Test Equipment: Lists all test equipment (standard or special) required to troubleshoot, test and inspect the equipment covered in this manual. The test equipment is identified with an item number and work package number from the *Tool Identification List* located in Chapter 4, *Supporting Information*.

Tools: Lists all tools (standard or special) required to perform the task. Tools are identified with an item number and work package number from the *Tool Identification List* located in Chapter 4, *Supporting Information*.

Personnel Required: Lists all personnel necessary to perform the task.

Equipment Condition: Notes the conditions that must exist before starting the task. The equipment condition will also include any prerequisite maintenance tasks to be performed with reference to the work package number or to the TM number.

References: Includes any other manuals necessary to complete the task. When there are no references listed, all steps necessary to complete the task are contained within this manual. A listing of reference materials is contained in the work package *References* in Chapter 4, *Supporting Information*.

Maintenance Instructions

To locate a maintenance procedure, open the manual to the Table of Contents located in the front of this manual. Find Chapter 4, *Maintenance Instructions*. Look down the list and find the maintenance procedure to be accomplished. On the right side of the maintenance procedure will be a work package number. Turn to the work package indicated.

Before beginning the maintenance task, look through the procedure to familiarize yourself with the entire maintenance procedure. At the top of the task you will have a section called INITIAL SETUP. There are five basic headings listed under INITIAL SETUP.

Tools: Lists all tools (standard or special) required to perform the task. Tools are identified with an item number and work package number from the *Tool Identification List* located in Chapter 4, *Supporting Information*.

Materials/Parts: Lists all parts or materials necessary to perform the task. Expendable and durables are identified with an item number from the applicable work package located in Chapter 4, *Supporting Information*.

Personnel Required: Lists all personnel necessary to perform the task.

References: Includes any other manuals necessary to complete the task. When there are no references listed, all steps necessary to complete the task are contained within this manual. A listing of reference materials is contained in the work package *References* in Chapter 4, *Supporting Information*.

Equipment Condition: Notes the conditions that must exist before starting the task. The equipment condition will also include any prerequisite maintenance tasks to be performed with reference to the work package number or to the TM number.

Test Equipment: Lists all test equipment (standard or special) required to troubleshoot, test and inspect the equipment covered in this manual. The test equipment is identified with an item number and work package number from the *Tool Identification List* located in Chapter 4, *Supporting Information*.

CHAPTER 1
DESCRIPTION AND THEORY OF OPERATION
FOR
CAUSEWAY FERRY (CF)

**OPERATOR MAINTENANCE
CAUSEWAY FERRY
GENERAL INFORMATION**

SCOPE

This manual contains descriptions and instructions for the Causeway Ferry (CF).

Type of Manual: Operator Maintenance.

Purpose of Equipment: The purpose of the CF is for Logistics Over The Shore (LOTS) deployment and handling of supplies between ship and beach. CF sections are connected together to form a floating powered causeway.

MAINTENANCE FORMS, RECORDS AND REPORTS

Department of the Army forms and procedures used for equipment maintenance will be those prescribed by DA PAM 738-750, The Army Maintenance Management System (TAMMS) and AR 700-138, Army Logistics Readiness and Sustainability.

REPORTING EQUIPMENT IMPROVEMENT RECOMMENDATIONS (EIR)

If any component in your system needs improvement, let us know. Send us an EIR. You, the user, are the only one who can tell us what you don't like about your equipment. Let us know why you don't like the design or performance. Put it on an SF 368, Product Quality Deficiency Report. Mail it to the address specified in DA PAM 738-750 or as specified by the contracting activity. We will send you a reply.

CORROSION PREVENTION AND CONTROL (CPC)

CPC of Army materiel is a continuing concern. It is important that any corrosion problems with this item be reported so that the problem can be corrected and improvements can be made to prevent the problem in future items.

While corrosion is typically associated with rusting of metals, it can also include deterioration of other materials, such as rubber and plastic. Unusual cracking, softening, swelling or breaking of the materials may be a corrosion problem. If a corrosion problem is identified, it can be reported using SF 368, Product Quality Deficiency Report. Use of key words such as "corrosion", "rust", "deterioration" or "cracking" will ensure that the information is identified as a CPC Problem. The form should be submitted to the address specified in DA PAM 738-750, Functional Users Manual for The Army Maintenance Management System (TAMMS).

OZONE DEPLETING SUBSTANCES (ODS)

The continued use of ODS has been prohibited by Executive Order 12856 of 3 August 1993.

DESTRUCTION OF ARMY MATERIEL TO PREVENT ENEMY USE

The procedures for destruction of Army materiel to prevent enemy use are contained in TM 750-244-6.

PREPARATION FOR STORAGE AND SHIPMENT REFERENCE

Reference WP 0035 10 through WP 0049 00 for preparation for storage or shipment of the CF.

LIST OF ABBREVIATIONS/ACRONYMS

Abbreviation/Acronym	Name
AC	Alternating Current
■ AEPS	Army Electronic Product Support
ANS	Answer
ANT	Antenna
AOAP	Army Oil Analysis Program
■ AR	Army Regulation
BII	Basic Issue Items
C	Centigrade
CAGEC	Commercial and Government Entity Code
■ CFBE	Causeway Ferry Beach End
CF	Causeway Ferry
CLR	Clear
cm	Centimeters
CO2	Carbon Dioxide
COEI	Components of End Item
CPC	Corrosion Prevention Control
CS	Causeway Section
CCW	Counterclockwise
CW	Clockwise
■ DA PAM	Department of Army Pamphlet
dB	Decibels
DC	Direct Current
Deg	Degrees
DSC	Digital Selective Calling
EIR	Equipment Improvement Recommendations
ESD	Electrostatic Discharge
F	Fahrenheit
FCC	Federal Communications Commission
■ FGC	Functional Group Code
fl	Fluid
■ FM	Field Manual
FNC	Function
FSS	Fast Sealift Ship
ft	Feet
■ ft lb	Foot Pound\Foot Pounds
FWD	Forward
GAL	Gallon
GFI	Ground Fault Indicator
GND	Ground
GPH	Gallons Per Hour
■ GPS	Global Positioning System
H	Height
H/L	High/Low
HP	Horse Power
Hz	Hertz
IAW	In Accordance With
ICM	Intercommunication (short-form)
ID	Identification
in.	Inches
■ in. lb	Inch Pound\Inch Pounds
INTL	International

LIST OF ABBREVIATIONS/ACRONYMS (CONT'D)

Abbreviation/Acronym	Name
ISO	International Standards Organization
ISOPAK	International Standards Organization Package
kg	Kilograms
kHz	Kilohertz
kW	Kilowatt
LASH	Lighter Aboard Ship
lb	Pound
LCD	Liquid Crystal Display
LED	Light Emittiing Diode
LOTS	Logistics Over the Shore
M	Meters
mA	Milliampere
MAC	Maintenance Allocation Chart
MCS	Modular Causeway System
MEM	Memory
MHz	Megahertz
ML	Milliliters
MTBE	Methyl Tertiary Butyl Ether
MTO&E	Modified Table of Organization and Equipment
NATO	North Atlantic Treaty Organization
NBC	Nuclear, Biological and Chemical
NEMA	National Electrical Manufacturers Association
NHA	Next Higher Assembly
Ni-Cd	Nickel Cadmium
NL	Navy Lighter
N-m	Newton-Meters
NOAA	National Oceanic and Atmospheric Administration
NSA	National Security Agency
NSN	National Stock Number
ODS	Ozone Depleting Substance
oz	Ounces
PLGR	Precision Lightweight Global Positioning Receiver
PMCS	Preventive Maintenance Checks and Services
PN	Part Number
PSI	Pounds Per Square Inch
PTT	Push To Talk
PWR	Power
rcv	Receive
RF	Radio Frequency
RPM	Revolutions Per Minute
RPSTL	Repair Parts and Special Tools List
SCR	Scrambler
SINCGARS	Single Channel Ground and Airborne Radio
SMR	Source, Maintenance Recoverability
SRA	Specialized Repair Activity
STBD	Starboard
sw	Switch
TACOM	United States Army Tank-Automotive and Armaments Command
TAMMS	The Army Maintenance Management System
TEL	Telephone
TMDE	Test, Measurement and Diagnostic Equipment

LIST OF ABBREVIATIONS/ACRONYMS (CONT'D)

Abbreviation/Acronym	Name
TO&E	Table of Organization and Equipment
Tx	Transmit
UTC	Coordinated Universal Time
uV	Ultra Violet
VAC	Voltage, Alternating Current
VDC	Voltage, Direct Current
VHF/FM	Very High Frequency/Frequency Modulation
W	Width
XMIT	Transmit

**OPERATOR MAINTENANCE
CAUSEWAY FERRY
DESCRIPTION AND DATA**

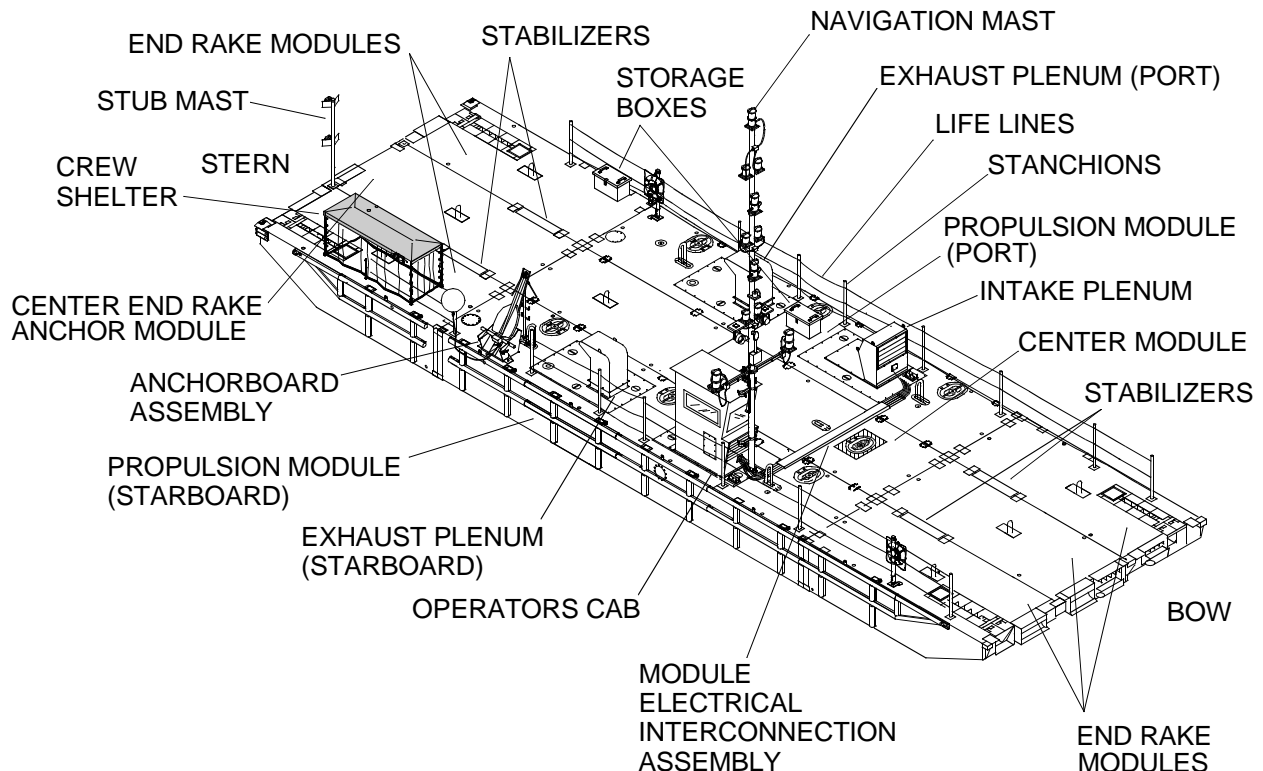
EQUIPMENT CHARACTERISTICS, CAPABILITIES AND FEATURES

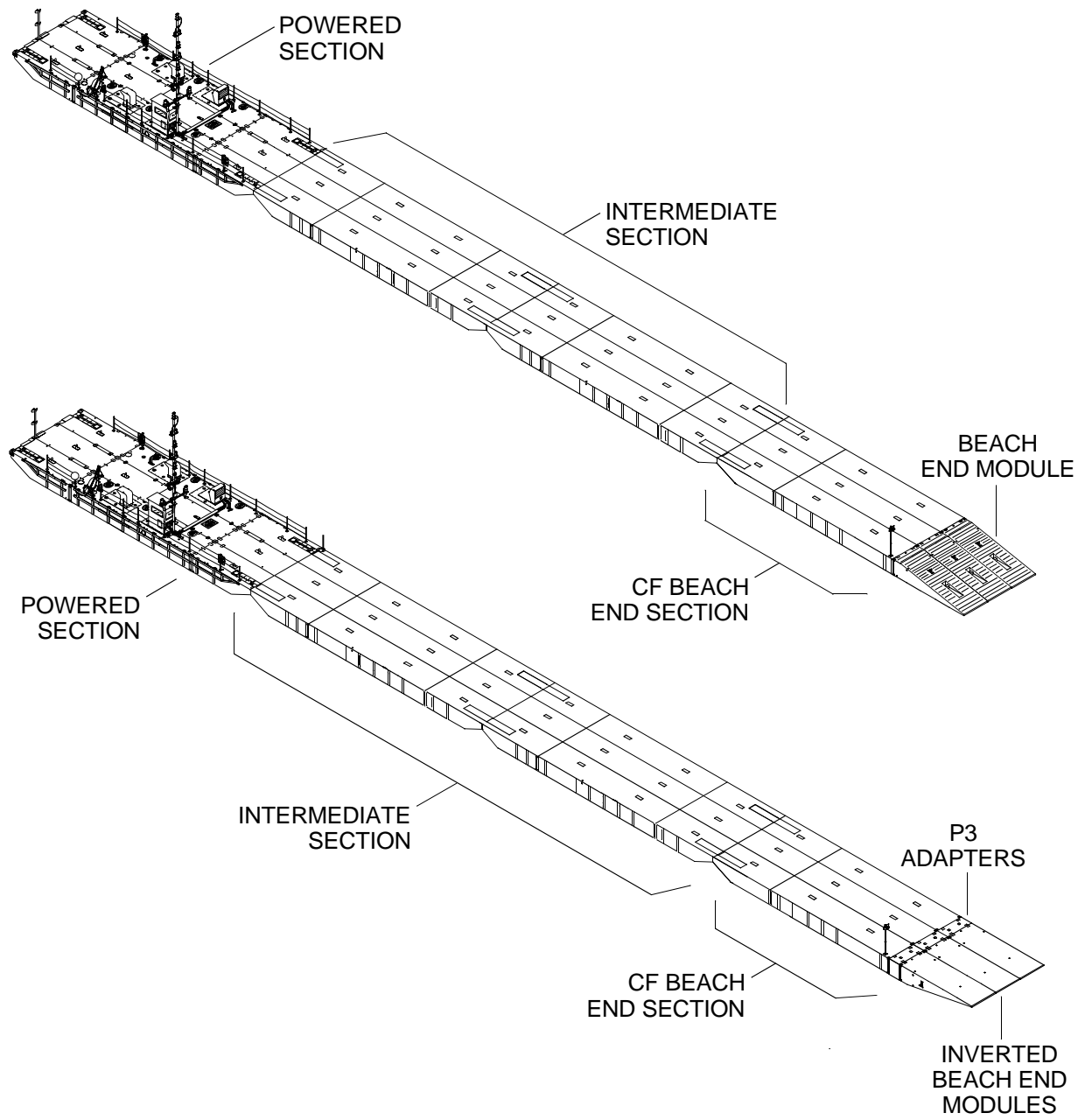
The Causeway Ferry (CF) system is a combination of modules assembled to form section assemblies. The assembled CF consists of four sections: one propulsion (powered) section, two non-powered intermediate sections and one causeway ferry beach end section. The powered section and the non-powered intermediate sections are 24 ft wide and 80 ft long. The non-powered causeway ferry beach end section is 24 ft wide and 85 ft long. When all four sections are connected end-to-end they form a single CF, 24 ft wide and 325 ft long. The powered section is assembled with two propulsion modules that facilitate self-powered movement and maneuvering. Individual modules are connected by male/female locking assemblies located around the perimeter of each module. Section assemblies are then connected end-to-end to form the completed CF. The system utilizes the Navy flexor and shear connector system for causeway end-to-end connection. It is interchangeable with existing Navy Lighter (NL) and Army hardware at the sectional level.

The powered section is fitted with an operators cab, intake/exhaust plenums, main navigational mast, stub mast, anchorboard assembly and life lines.

The CF is used to transport containerized, rolling break bulk cargo from ocean going vessels in the stream to the beach. The disassembled components of the CF are transported in an International Standards Organization Package (ISOPAK) configuration by Fast Sealift Ship (FSS) and/or commercial container ships to the operational area. They are assembled after arrival. The CF modules are ISO container compatible and are outfitted with ISO corner fittings. Components can also be transported by rail and motor vehicle over improved and unimproved roads. Upon arrival in the operational area, the CF can be assembled on deck, land and/or in water at Sea State 0. The CF is designed to augment the Modular Causeway System (MCS) in applications where powered assemblies are required.

The CF, with maximum payload, is capable of beaching and retracting under its own power in those gradients commonly found in beach environments and operating in surf conditions up to 5 ft.





CAUSEWAY FERRY SYSTEM

**OPERATOR MAINTENANCE
CAUSEWAY FERRY
DESCRIPTION AND DATA**

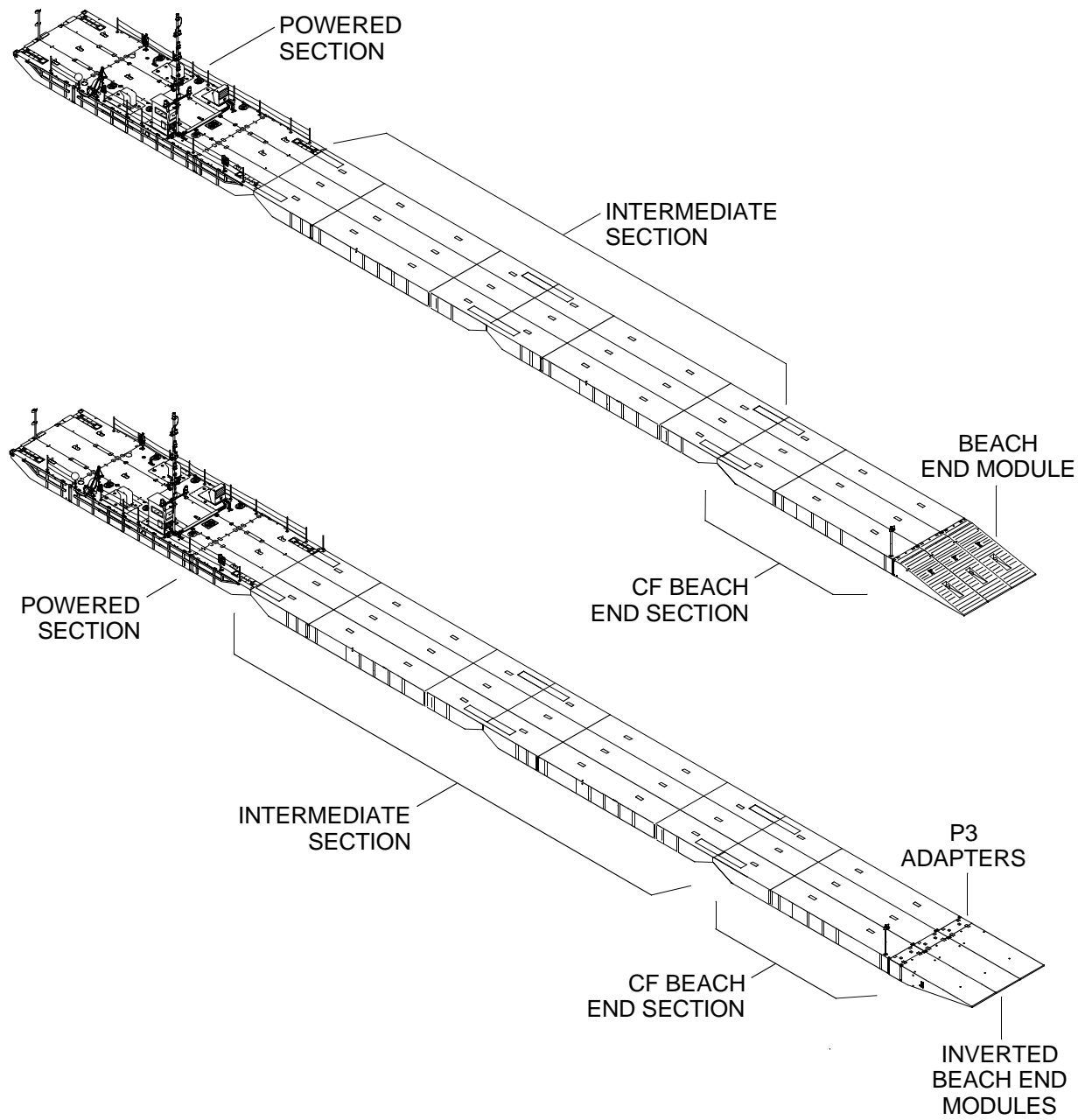
LOCATION AND DESCRIPTION OF MAJOR COMPONENTS

CAUSEWAY FERRY SYSTEM

The Causeway Ferry (CF) system consists of one powered section, a number of intermediate sections and one causeway ferry beach/sea end section. The powered section consist of the following: two propulsion modules, non-powered center module, six end rake modules, (two right, two left and two center), operators cab, intake/exhaust plenums, main navigation and stub masts, module electrical interconnect assembly, anchor board and life lines. The powered section is the prime mover for the CF and is powered by two 8 cylinder, 600 hp water cooled, marine diesel engines driving two 360° steerable, 5,000 lb output pump-jets. The intermediate sections are assembled with three non-powered center modules and six end rake modules. The causeway ferry beach end section consists of three non-powered center modules, three end rakes and three beach end modules. The completely assembled CF is 325 ft long, 24 foot wide. When operating in an optional configuration, using P3 adaptor modules called inverted beach end modules, the length is increased to approximately 329 ft.

The modules are connected together by male/female locking assemblies. At each connector location there are upper and lower engagement points. Both engagement points are actuated simultaneously by lifting the guillotine bar vertically from the deck. The pairs of vertical connectors are spaced evenly around the perimeter of each module allowing for universal module configuration. The male connector assembly contains a retractable connector pin designed to be flush with the surface when in a stowed position. In the stowed position, the tapered shear lugs of the lock housings protrude around the pin housing. In the retracted position, the pin is compressed against the deployment spring and is held in place by the guillotine bar. The female connector assembly receives the male connector pin and when locked, forms a positive mechanical interlock. The female connector assembly can be identified by the projecting shear lug which completely surrounds the housing. The female connector shear lug is internally tapered and sized to fit tightly with the mating lugs on the opposing male connector. This arrangement enhances the strength of the connectors, enabling it to withstand heavy shear loads.

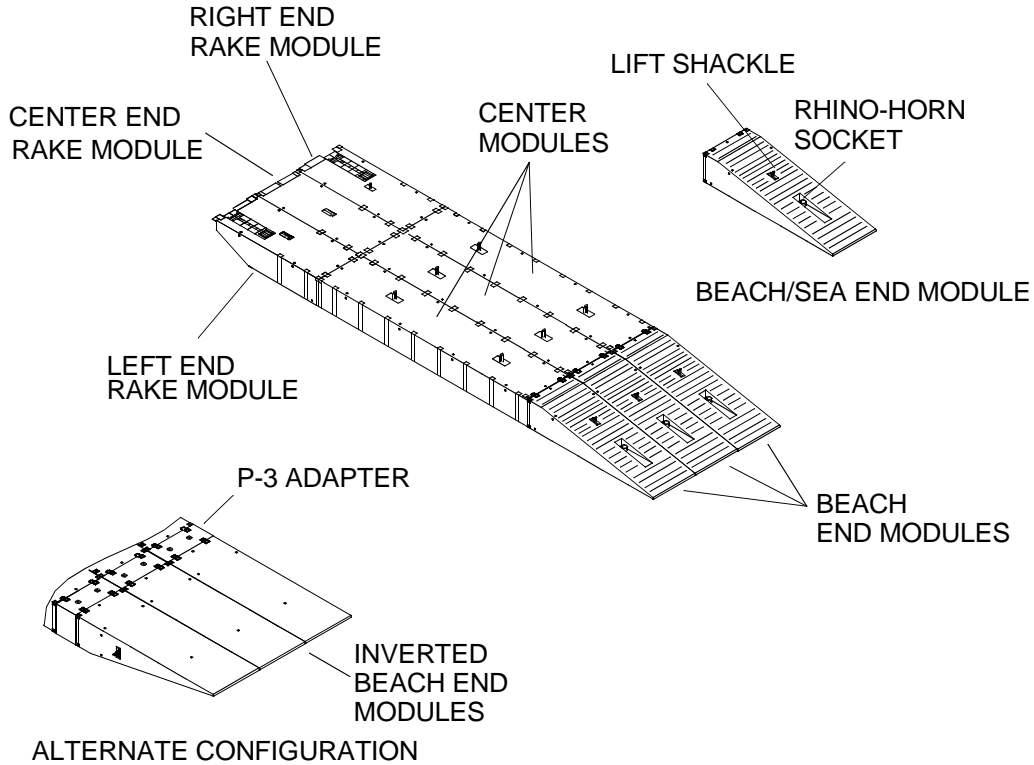
The fully assembled CF has a cargo capacity of 350 short tons and can maintain a speed of 6 knots at a maximum load capacity in SEA STATE 2. The powered section carries enough fuel to operate under these conditions for 10 hours. The fully loaded CF will maintain a minimum vertical distance from the surface of the water to the gunwale (freeboard) of approximately 12 in., it can execute a 180° turn within two minutes, a 360° turn within four minutes and can be brought from full speed of 6 knots to a complete stop within 320 ft.



CAUSEWAY FERRY SYSTEM

CAUSEWAY FERRY BEACH END SECTION AND P-3 ADAPTOR

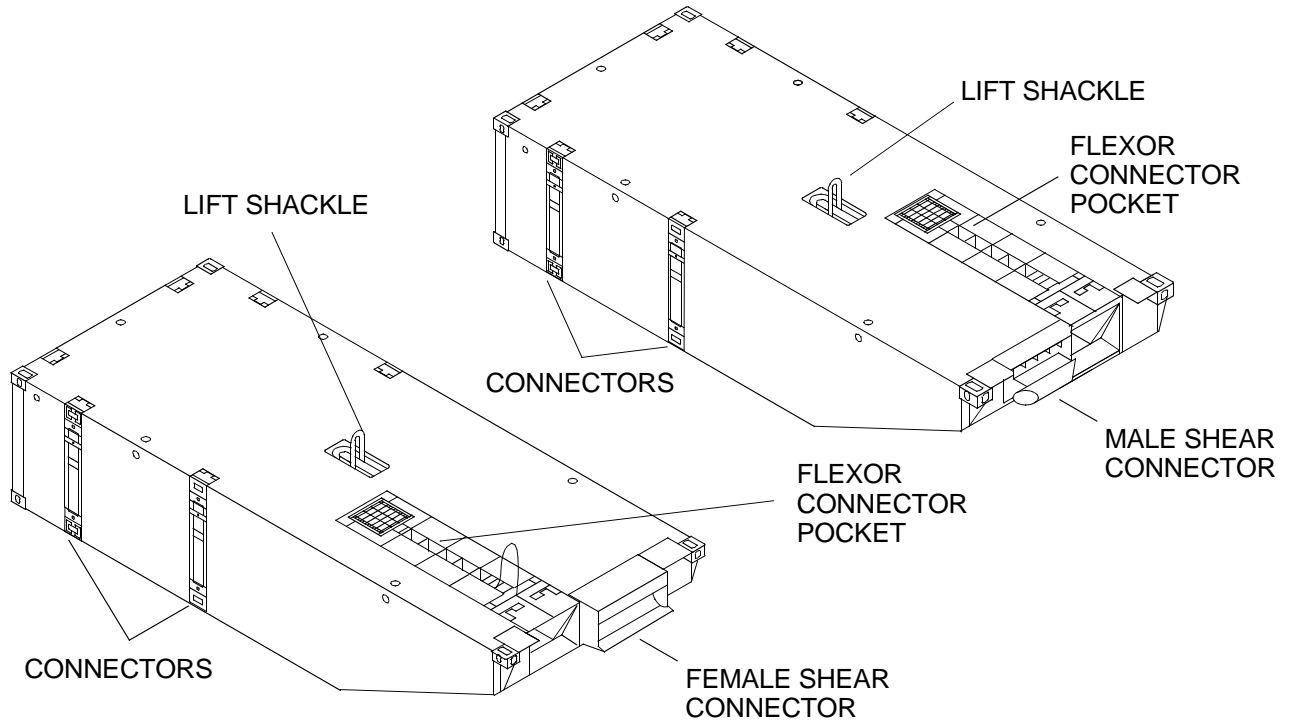
The causeway ferry beach end section is attached to the last intermediate section of the beach end of the causeway. The causeway ferry beach end section is made up of three center modules, three end modules (left, center and right) and three beach/sea end modules. The beach end section weighs approximately 37,500 lb, are 8 ft wide, 3 ft long, 4 ft 6 inches high and provide an alternate configuration capability. The P3 adaptors allow the beach end modules to be mated in the inverted position, referred to as inverted beach end modules.



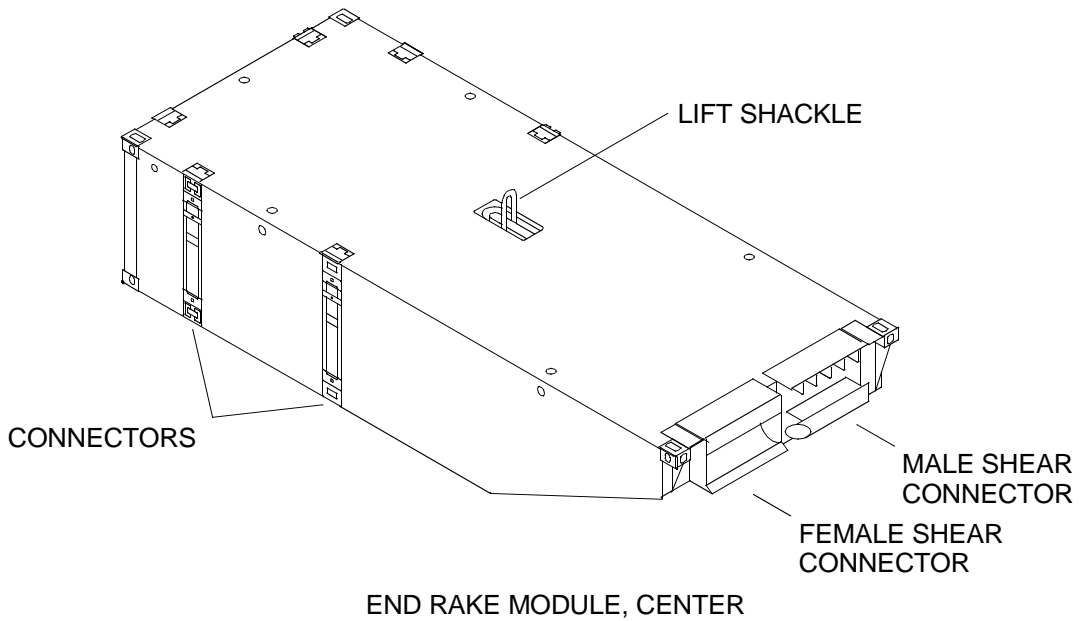
COMBINATION BEACH/SEA END SECTION

END RAKE MODULES

The left, right and center end rake modules are empty modules which are 8 ft wide, 20 ft long and 4 ft 6 in. high. Each left, right and center end rake module has one 25 ton capacity lifting shackle, which is flush mounted in the deck. The textured deck and smooth bottom are free of any protrusions that might obstruct packing. Access for internal leak detection of each compartment is provided by a recessed threaded plug. The left end rake has a flexor connector pocket for flexor connector installation in the left corner of the module. The right end rake has a flexor connector pocket for flexor connector installation in the right corner of the module. Weight of the left, right and center end rake modules is approximately 12,500 lb.

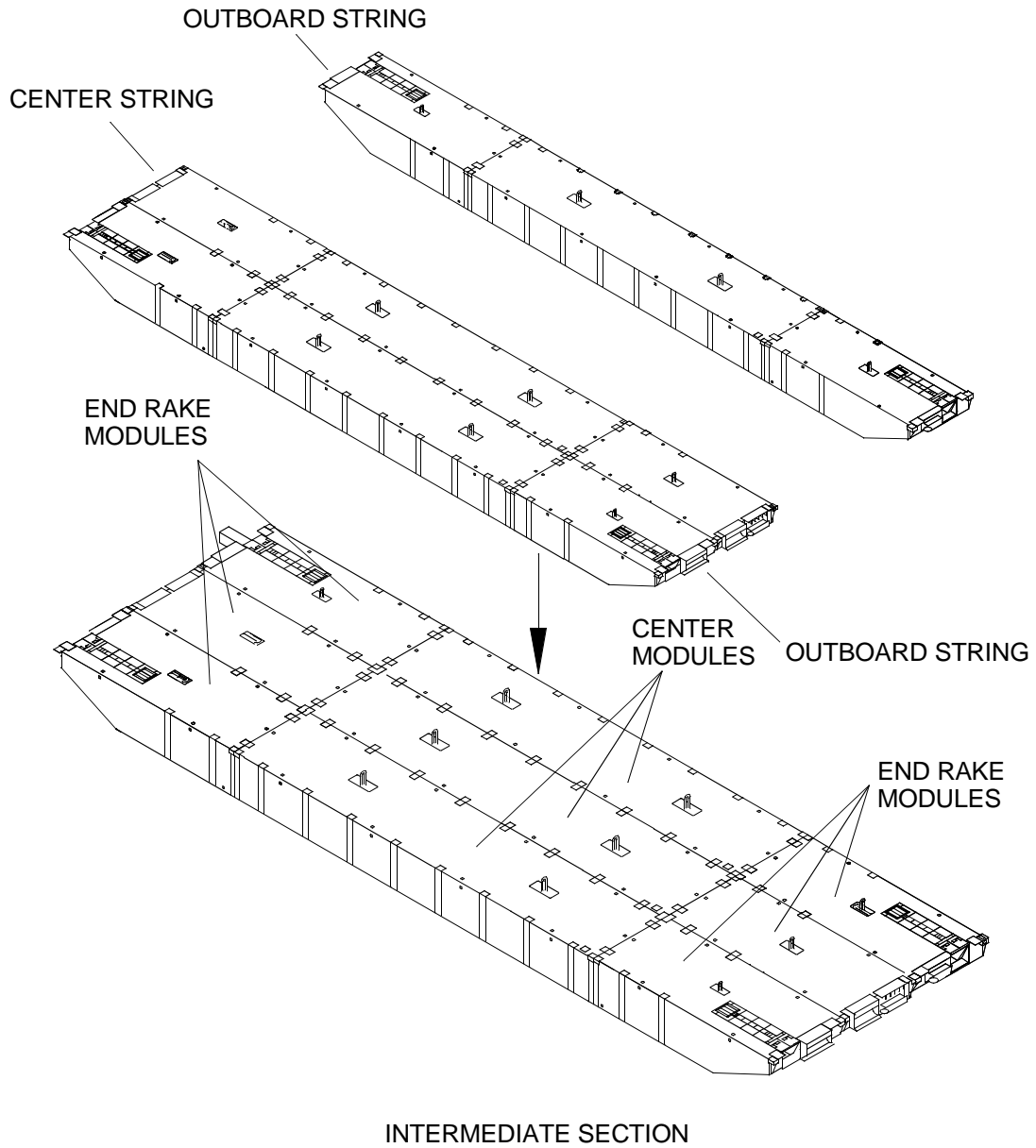


END RAKE MODULES, LEFT HAND (PORT) AND RIGHT HAND (STARBOARD)



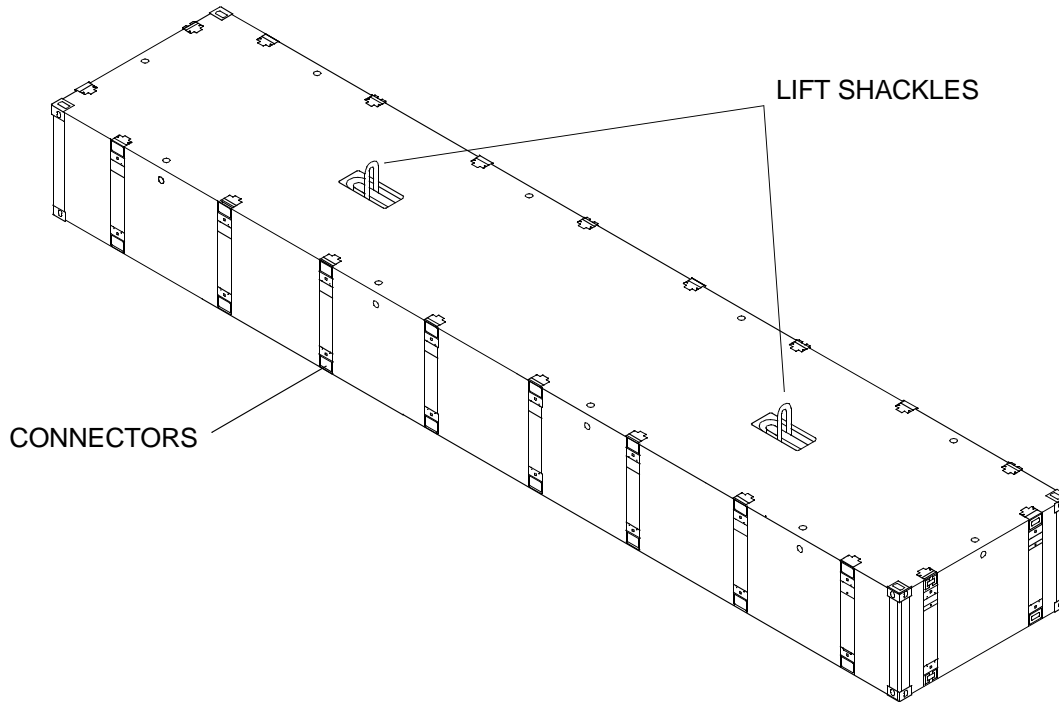
INTERMEDIATE SECTION

The intermediate section is attached to other intermediate sections to construct a CF segment. The intermediate section is made up of three non-powered center modules and six end rake modules. All end rakes are fully compatible with U.S. Navy flexor attachments and shear connectors are fully compatible with ISO container standards. The complete assembled intermediate section is 80 ft long, 24 ft wide, 4 ft 6 in. high and weighs approximately 142,500 lb.



CENTER MODULE

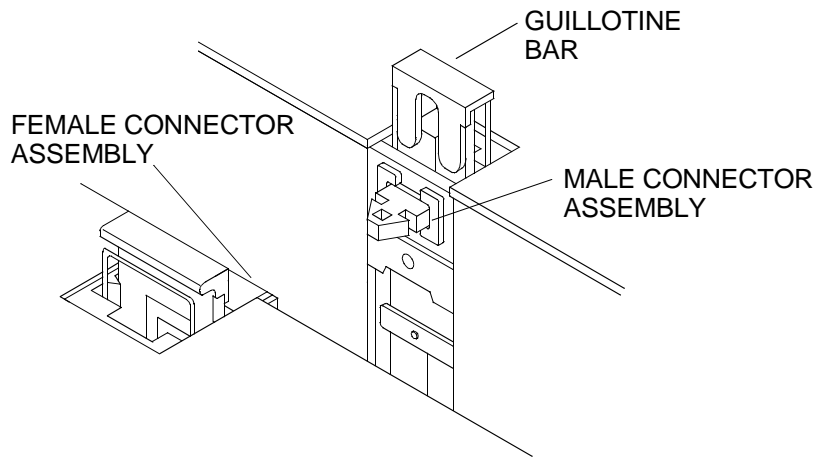
The non-powered center module is an empty module which is 8 ft wide, 40 ft long, 4 ft 6 in. high and is ISO compatible. Each center module has two 25 ton capacity lifting shackles, flush mounted in the deck. The textured deck and smooth bottom are free of any protrusions that might obstruct stacking. Access for internal leak detection of each compartment is provided by three recessed threaded plugs. Alternating male and female connectors are equally spaced along both sides and ends of the center module. These connectors are stowed flush with the surface and, when deployed, connect modules with minimum clearance. Weight of the center module is approximately 22,500 lb.



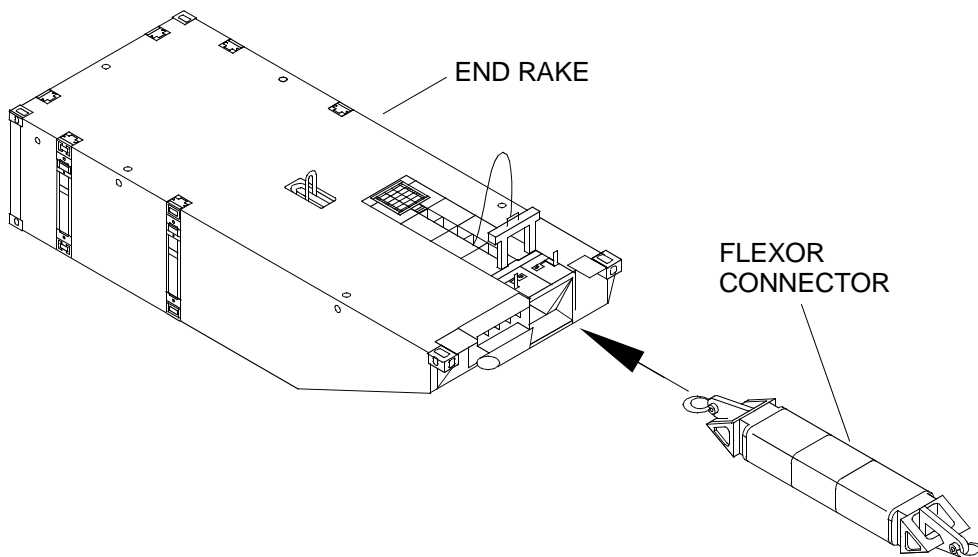
NON-POWERED CENTER MODULE

CONNECTOR ASSEMBLIES

The modules are connected together by male/female connector assemblies. At each connector location there are upper and lower engagement points. Both engagement points are actuated simultaneously by lifting the guillotine bar vertically from the deck. The pairs of vertical connectors are spaced evenly around the perimeter of each module allowing for universal module configuration. The male connector assembly contains a retractable connector pin designed to be flush with the surface when in a stowed position. In the stowed position, the tapered shear lugs of the lock housings protrude around the pin housing. In the retracted position, the pin is compressed against the deployment spring and is held in place by the guillotine bar. The female connector assembly receives the male connector pin and when locked, forms a positive mechanical interlock. The female connector assembly can be identified by the projecting shear lug which completely surrounds the housing. The female connector shear lug is internally tapered and sized to fit tightly with the mating lugs on the opposing male connector. This arrangement enhances the strength of the connectors, enabling it to withstand heavy shear loads. Flexor connectors are used in the right and left end rakes when connecting sections together. The flexor is designed to reduce and relieve dynamic loads that occur as a result of relative motions and tug induced forces.

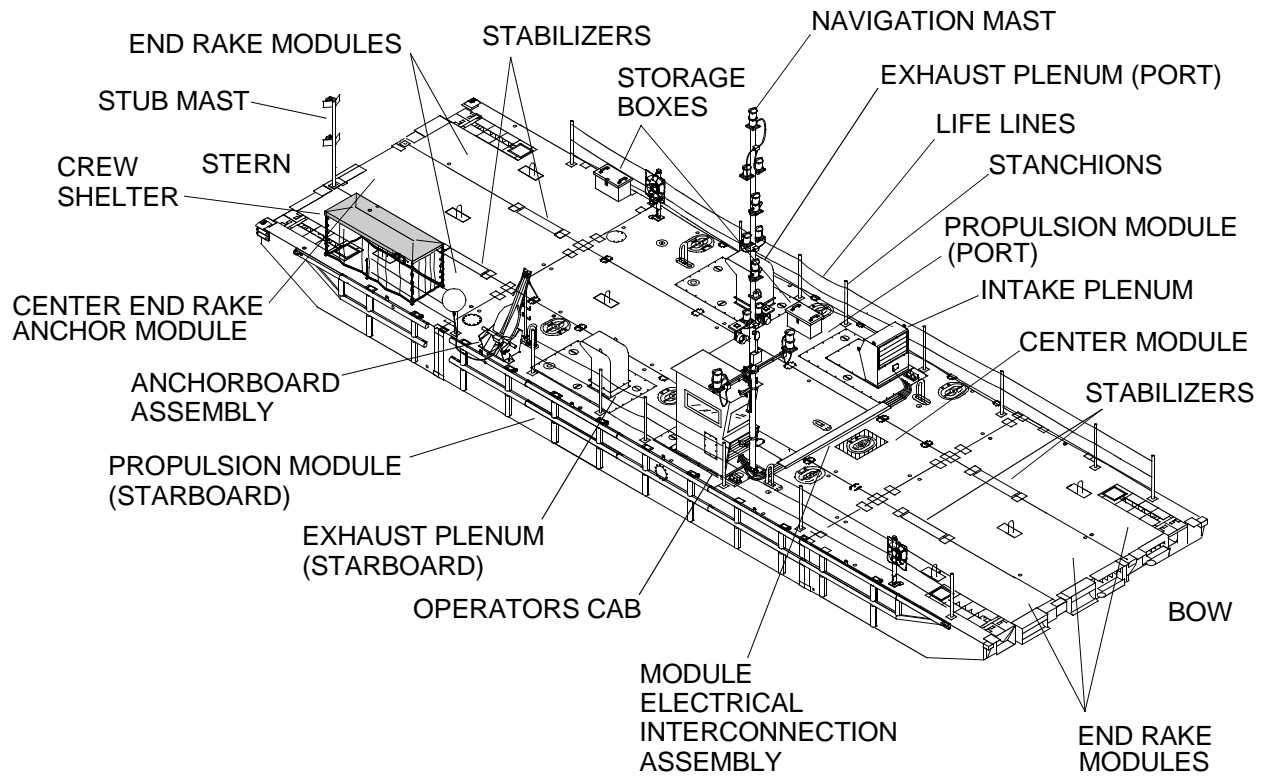


MALE/FEMALE CONNECTOR ASSEMBLY



POWERED SECTION

The powered section is made up of two propulsion (powered) modules, one non-powered center module that are 8 ft wide, 40 ft long and 4 ft 6 in. high and six end rake modules (two right, two left, and two center) that are 8 ft wide and 20 ft long. The individual modules are connected together by male/female locking assemblies located around the perimeter of each module. The powered section is the prime mover for the CF and is propelled by two 8 cylinder, 600 HP, diesel marine engines driving two 360° steerable, 5,000 lb output, pump-jets. The operators cab, with controls, is a self-contained unit designed to be removed for transport and can be mounted on either port or starboard propulsion module. Plug-in type electrical connectors are provided to tie electrical control into the cab location. A module electrical interconnect assembly is the electrical control link between the cab to the propulsion module opposite the cab. Jumper cables are supplied for movement of the cab from the operational position to a location on the deck for the performance of engine maintenance. Navigation lighting is provided in the form of a 28½ foot, main navigational mast mounted on the cab and a 8½ foot stub mast that is installed at the extreme aft end of the powered section. Both masts are removable for shipment. Raising and lowering of the navigation mast can be accomplished by the installed winch/cable system. Deck work lights are attached to the navigation mast to provide illumination for night operations. Air intake and exhaust plenums are installed on the powered modules to provide air flow through the machinery spaces. One of the air intakes is integral to the cab. A hand held portable fire extinguisher mounts to either exhaust plenum. An anchorboard assembly with a 1,500 lb anchor mounts to the starboard propulsion module, aft of the exhaust plenum. A removable personnel safety railing system made up of stanchions and life lines, is installed along both sides. The powered section, completely assembled and without fuel weighs approximately 95 tons.



PROPULSION MODULE

The propulsion module is the prime module in the CF and is divided into three compartments separated by watertight bulkheads with hatches. The center (machinery) compartment is the largest and contains the following; engine cooling, exhaust components, drive train, hydraulic system and any electrical components not stored in lazaret compartment. Located in the lazaret end compartment are: one bilge pump, a single bilge pump control panel and a pressure operated switch.

The drive train consists of the following: engine, marine gear, transfer case and pump-jet. Guarded drive shafts connect the marine gear to the transfer case and the transfer case to the pump-jet.

The engine cooling and exhaust system consists of the following: sea chest, butterfly valve, duplex strainer, engine raw water pump, fuel cooler, engine cooler heat exchanger, marine gear oil cooler, exhaust water shut-off valve, transfer case oil cooler, transfer case shut-off ball valve, water cooled muffler and exhaust flappers.

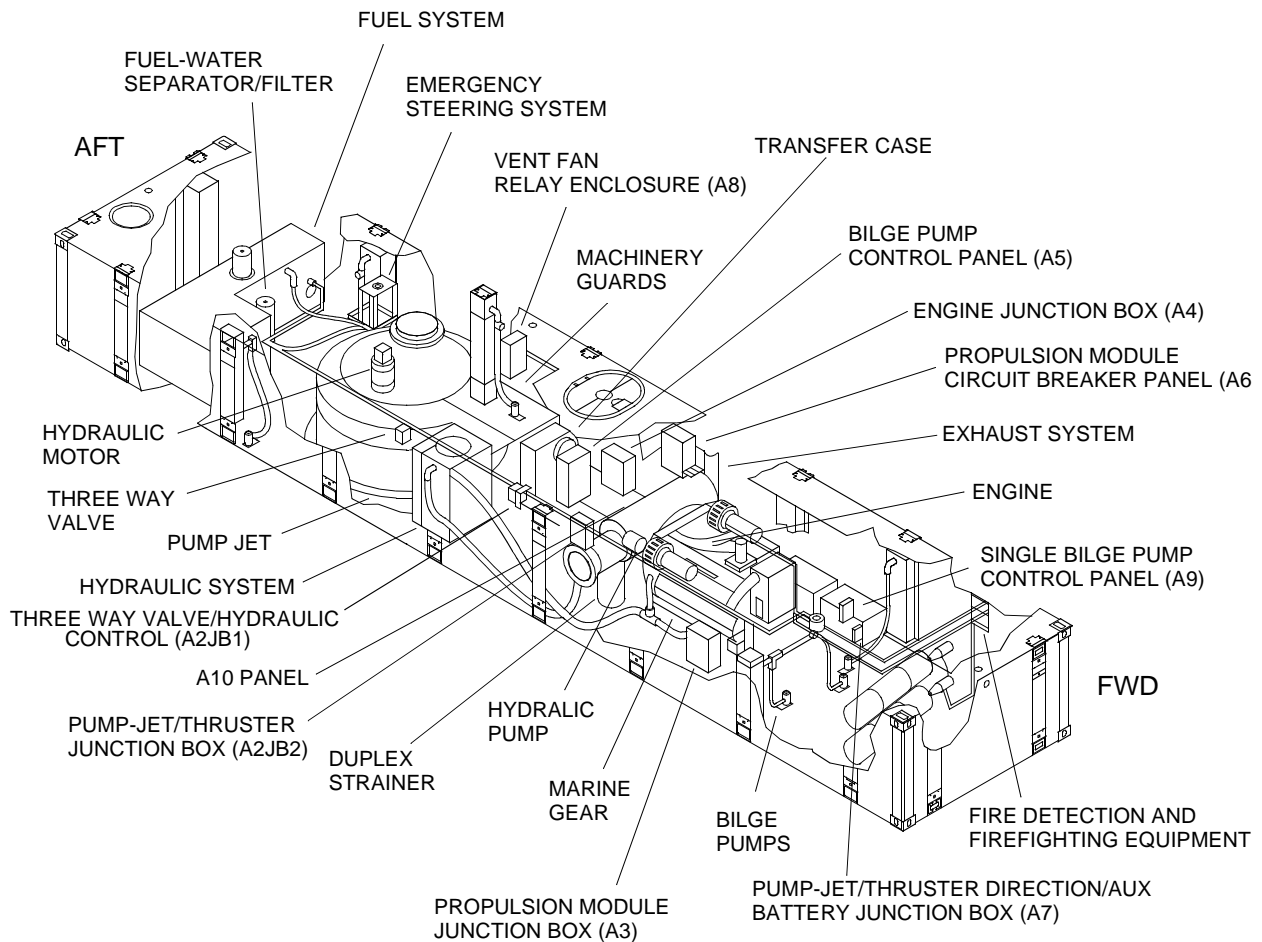
The hydraulic system consists of a hydraulic pump driven by the marine gear, a hydraulic motor that drives the primary steering planetary gearbox (mounted on the pump-jet), a hydraulic brake (mounted on the pump-jet), an electrically actuated way-valve with auxiliary manual control, manually operated ball valve, needle valve, braking valve unit, pressure filter and a hydraulic reservoir with return line filter. A manual hydraulic hand pump is also provided for manual release of the hydraulic brake in case of system malfunction.

The propulsion module electrical system consists of an engine mounted alternator, six lead-acid storage batteries, propulsion module circuit breaker panel A6, battery selector switch, high current multi-battery solenoid and operators cab 50 amp circuit breaker all located on the A10 panel, bilge pump control panel A5, single bilge pump control panel A7, engine junction box with emergency stop control A4, emergency stop push button, propulsion module junction box A3, pump-jet thruster junction box A2JB2, vent fan relay enclosure A8, pump-jet thruster direction/auxiliary battery junction box A9, fire detection system consisting of two thermal detectors and a thermal switch electrically tied into the cab controls. This compartment is also equipped with five electrically operated bilge pumps.

The aft (fuel) compartment contains the fuel tank, fuel/water separator and fuel system shutoff valves. This compartment is also protected by the fire detection system. It is important to note that there are no electrical connections, controls or operating devices in this compartment. A bilge pump is not provided in this compartment. Fire detection is accomplished by means of a probe extending through the bulkhead that separates the fuel and machinery compartments with all electrical terminations made on the machinery compartment side. In the event of fire, this compartment is flooded with CO₂ upon activation of the fire suppression system.

The forward compartment (lazaret) contains the fire suppression system control and agent storage components and provides stowage for the emergency steering assembly when not in use. This compartment is equipped with a bilge pump and is not protected by the fire suppression system.

Each propulsion module has six 3,700 gph submersible bilge pumps; five in the machinery compartment and one in the lazaret. The pumps are locally controlled from control stations mounted in the machinery compartment and lazaret or remotely controlled from the operators cab. The pump-jet is driven by an 8 cylinder, marine diesel engine, delivering 600 hp at 2,100 RPM on the output shaft. Weight of the propulsion module is approximately 41,100 lb dry or 45,000 lb fully loaded. Listed below are detailed descriptions of the major components found in each propulsion module.



PROPULSION MODULE MAJOR INTERNAL COMPONENTS

Engine

The engine is an 8 cylinder, water cooled, turbo charged, after cooled, two cycle diesel marine engine, delivering 600 hp at 2,100 RPM. Control of the engine is accomplished from the operators cab, with the exception of below deck emergency stop push buttons and emergency stop actuation control of the fire suppression system.

Exhaust System

The propulsion module exhaust system consists of a water cooled muffler assembly with inputs directly coupled from both engine turbocharger exhaust ports. The muffler is supplied with two exit ports. One is plugged and one is ported to the exhaust flapper for configuration as either a port or starboard exhaust system. The piping between the turbocharger, muffler and exhaust flapper is a flexible silicone hose to accommodate for thermal expansion in the system.

Fuel System

Each propulsion module is equipped with a 400 gallon stainless steel fuel tank permanently welded inside the fuel compartment. Fuel suction and return lines are fitted with shut-off ball valves to isolate fuel to the tank when not in use or during repairs to the fuel system. A filler neck/strainer basket located on top of the fuel tank is accessible through a deck hatch from outside the fuel compartment.

Fuel-Water Separator/Filter

A dual purpose fuel-water separator and filter is located near the fuel tank in the fuel tank compartment at the rear of the module. Its main function is to remove water and contaminants from the diesel fuel.

Marine Gear

The marine gear provides the capability to reverse the directional rotation of the other drive train components. This allows backflushing of the pump-jet and is mounted directly to the flywheel housing of the diesel engine. The transmission is equipped with an integral hydraulic system consisting of a pump, shifting valve and internal hydraulic cylinders. The pump utilizes the transmission lubricating oil to operate hydraulic cylinders which shifts the gears to the backflush, neutral or engaged configurations. The shifting valve is solenoid actuated from a toggle control switch in the operators cab. In addition to powering the shifting cylinders, the pump also circulates case oil through an oil cooler that is plumbed into the engine raw water cooling system. In the event of electrical power loss to the marine gear shifting solenoids, an emergency engagement capability is provided for the marine gear by replacing a shifting valve solenoid with an emergency lock-up plug that locks the transmission gearing. The lock-up plug is used to provide independent forward or backflush capabilities and is mounted externally to the shifting valve solenoid housing.

Transfer Case

The transfer case compensates for off-set alignment between the output flange of the marine gear and the input flange of the pump-jet. It has a 1:1 gear ratio, utilizing spur gears throughout and is equipped with an oil pump that circulates lubricating oil from its gearcase through an oil cooler. The oil cooler is plumbed off of the engine raw water cooling system and back to the top of the transfer case to lubricate the upper gearing. The transfer case is connected to the marine gear and the pump-jet via drive shafts.

Machinery Guards

Removable metal machinery guards cover the drive shafts, engine flywheel and alternator belt to protect personnel from contact with rotating parts.

Pump-Jet

Each propulsion module is equipped with a 360° steerable pump-jet propulsion unit capable of delivering 5,000 lb of thrust. The pump-jet works on the principal of a rotary pump and consists of a drive shaft that drives an upper gearbox assembly which drives an impeller. Water is drawn into the pump-jet through a feeding funnel on the bottom of the module and fed into the enclosed pressure casing. The pressure casing bottom plate is provided with three systematically arranged outlet nozzles from which water is ejected at a 13° angle. A hydraulic steering motor drives a spur gear through a planetary gearbox to rotate the pressure casing and steering nozzles, located on the bottom, in both senses of rotation without limitation. A second planetary gearbox is provided to facilitate emergency steering. The emergency steering control stand is mounted above deck and interfaces with the through shaft of the planetary gearbox. The emergency steering gearbox contains a spring set, hydraulically released disc brake. The brake maintains the position of the steering nozzle until rotation is called for by the operator. In the event of hydraulic system failure the brake can be released via the hydraulic hand pump to facilitate emergency steering. An electromechanical feedback unit monitors relative steering position of the steering nozzle and transmits that position to a dial indicator in the operators cab. An electric sensor monitors the oil level in the upper gearbox and sends a signal to an indicating light in the operators cab, when the oil level is below the required level.

Duplex Strainer

The duplex strainer is located by the diesel engine and is considered part of the raw water system. Its purpose is to collect debris from raw seawater and prevent it from entering the raw water pump.

Hydraulic System

The hydraulic system contained within each propulsion module provides the steering control for the pump-jet. The system includes an axial piston hydraulic pump (mounted off the marine gear), a fixed displacement hydraulic motor (mounted to the planetary gear drive off the pump-jet), hydraulic brake, control valves, filters and a 26 gallon hydraulic reservoir. The reservoir is fitted with an external sight level, in-tank suction strainer and in-tank return line filter. A pressure filter is located between the hydraulic pump and the way-valve control block. The interconnect piping between components includes a short section of hose to minimize the effects of vibration.

Hydraulic Pump

A flange mounted, axial piston hydraulic pump driven by the marine gear provides hydraulic pressure to operate the hydraulic steering motor and normal release of the hydraulic steering brake.

Hydraulic Motor

A fixed displacement, axial piston hydraulic motor is flange mounted on the input shaft of the (steering) pump-jet steering planetary gearbox. Hydraulic flow from the hydraulic pump is directed through the way-valve unit to drive the hydraulic motor in a clockwise or counterclockwise direction to rotate the steering nozzles.

Way-Valve Unit

The way-valve is controlled hydraulically by means of electrically operated pressure control valves or manually by means of a control lever mounted on the valve unit assembly. The way-valve directs hydraulic fluid via the load retaining valve, which controls directional rotation of the hydraulic motor. A brake valve (located on the pump-jet) directs hydraulic pressure to the emergency steering planetary gearbox to release the hydraulic brake when rotation of the hydraulic motor is initiated.

Three-Way-Valve

A manually operated control handle on the valve is positioned to select normal hydraulic operation or to isolate the normal hydraulics so that the emergency steering hydraulic hand pump can be used to release the hydraulic brake in the emergency steering mode.

Hydraulic Reservoir

The hydraulic reservoir is a 26 gallon holding tank for the system hydraulic fluid. The tank is equipped with a fill and drain port (for replenishment of the fluid), a sight gauge (to determine fluid level) and a return line filter (with dirt indicator) to filter hydraulic fluid returning to the tank and outlet line strainer. The tank has a removable access panel to facilitate cleaning. A float switch monitors fluid level and lights an indicating light in the operators cab if the fluid level is below the required level.

Bilge Pumps

Each propulsion module is equipped with six bilge pumps capable of pumping a total of 3,700 GPH in the event the propulsion module takes on water. Five are located in the machinery compartment and one in the forward lazaret. The pumps can be controlled remotely from the operators cab by toggle switches and can be tested locally at the bilge pump control panels.

Fire Detection and Fire Fighting Equipment

A fixed CO₂ fire suppression system is designed to flood the engine, pump-jet compartment and the fuel storage compartment with CO₂, if a fire occurs. Thermal detection probes activate an alarm in the operators cab if the temperature in the propulsion module reaches 225°F. One is mounted below the deck through the bulkhead behind the pump-jet to monitor the fuel compartment. The other one is mounted below the deck to monitor the machinery compartment. There is no thermal detector in the lazaret compartment. In the operators cab on terminal strip A4, the fire alarm horn speaker will sound. The lower control panel in the operators cab has PORT FIRE ALARM and STBD FIRE ALARM red indicator lights. Above deck manual activation is accomplished using a remote cable pull box recessed in the deck and located directly in front of the access hatch and forward of the operators cab. Pulling the handle activates the fire suppression system and floods the compartment with CO₂. A below deck manual release is located on the upper 50 lb bottle. When any of the fire suppression controls are manually pulled, four events occur:

- (1) Activates fixed time delayed CO₂ fire suppression system that, 30 seconds later, discharges into propulsion module to suffocate fire.
- (2) Cable disconnects from intake plenum inner vent cover causing it to close and shut off oxygen sources.
- (3) Cable action shuts off relay for exhaust fan in exhaust plenum.
- (4) Activates pressure trip mechanism to shut off diesel engine.

A portable CO₂ fire extinguisher is mounted on either exhaust plenum.

Emergency Steering System

Each propulsion module is equipped with an emergency steering system consisting of a mounting stand, shaft with pillow block bearing support and hand crank. It is stored in the lazaret and is used to manually maneuver the CF in the event of a hydraulic system failure.

Pump-Jet Thruster Junction Box (A2JB2)

The pump-jet thruster junction box is mounted opposite the personnel access hatch approximately midway in the machinery compartment. The box contains relays and circuitry necessary to operate the way-valve steering solenoids circuit breaker for over-current protection.

Pump-Jet Thruster Direction/Auxiliary Battery Junction Box (A9)

The pump-jet thruster direction/aux. battery junction box is mounted on the machinery compartment side of the bulkhead that separates the machinery compartment and the lazaret. The box contains a battery charging circuit, two 24VDC auxiliary battery packs, control relay and two terminal blocks. The enclosure is vented due to possible off-gassing of the batteries.

Propulsion Module Junction Box (A3)

The propulsion module junction box is located forward in the machinery compartment opposite the main storage batteries. The box is the termination point for connection of three of the four main power cables that connect the propulsion modules to the cab.

Engine Junction Box (A4)

The engine junction box is located inboard and next to the personnel access hatch. It is a steel enclosure that contains the diesel engine governor controller, terminal strips, two relays controlling the emergency stop air flap solenoid and the emergency malfunction bell. An engine emergency stop push button is mounted to the enclosure cover.

Bilge Pump Control Panel (A5)

The bilge pump control panel is mounted very near the center line of the propulsion module inboard of the personnel access hatch. The panel consists of a steel enclosure with five toggle switches, one for each bilge pump in the machinery compartment.

Propulsion Module Circuit Breaker Panel (A6)

The propulsion module circuit breaker panel is located in the machinery compartment, opposite the engine junction box, next to the personnel access hatch. The panel is a steel enclosure with 14 circuit breakers mounted to the enclosure cover. Thirteen circuit breakers are protected by a plexiglas guard plate mounted with stand-offs. Access slots permit operation of the circuit breakers while protecting them from accidental shut off or damage.

Single Bilge Pump Control Panel (A7)

The single bilge pump control panel is located in the lazaret and consists of a steel enclosure mounted to the bulkhead that separates the lazaret from the machinery compartment. A single toggle switch for the lazaret bilge pump operation is mounted to the enclosure cover.

Vent Fan Relay Enclosure (A8)

The vent fan relay enclosure is located in the machinery compartment just forward of the pump-jet on the same side as the personnel access hatch. The assembly consists of a steel enclosure with a plug-in type receptacle located on the bottom. The enclosure is the power source for vent fan operation and contains the relay for fan operation. Once the exhaust plenum is mounted, the power cord that is hard wired to the fan can be plugged into the receptacle to complete the installation. A screw-on cover protects the receptacle when not in use. The power cord from the fan is equipped with a screw cap that matches the receptacle thread to secure the cord to the enclosure.

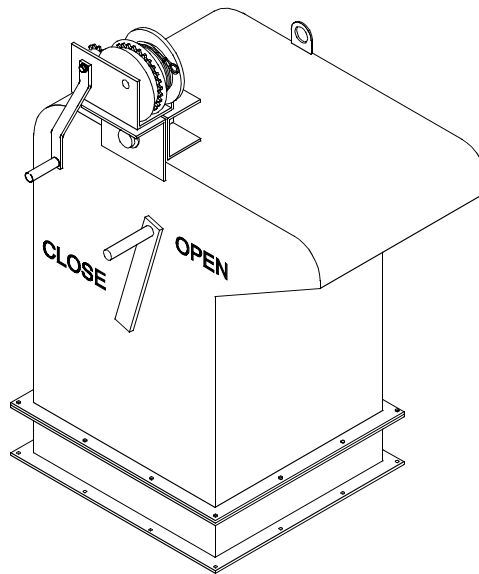
A10 Panel

The propulsion module A10 panel consists of the battery selector switch, high current multi-battery solenoid and operators cab 50 amp circuit breaker. The A10 panel is located in the propulsion module near the engine muffler. The 50 amp circuit breaker must be in the ON (closed) position and the battery selector switch in either position one or two for the operators cab to receive power.

VENTILATION

Although not a part of the propulsion module itself, the intake plenum is mounted over the engine. The other air intake is located in the operators cab. The intake plenum access panel allows connection of the module electrical interconnect cable to the engine operation receptacles. The exhaust plenums are mounted over the pump-jet. The plenums facilitate the fresh air flow through the compartment and limit the engine compartment to a temperature rise of 20°F above ambient temperature. The exhaust plenum has a flapper door (damper) that is manually opened and closed. In the closed position it eliminates a second source of air to any fire below deck.

Located on top of the exhaust plenum is a manual winch that is used to raise and lower the main navigational mast.



OPERATORS CAB

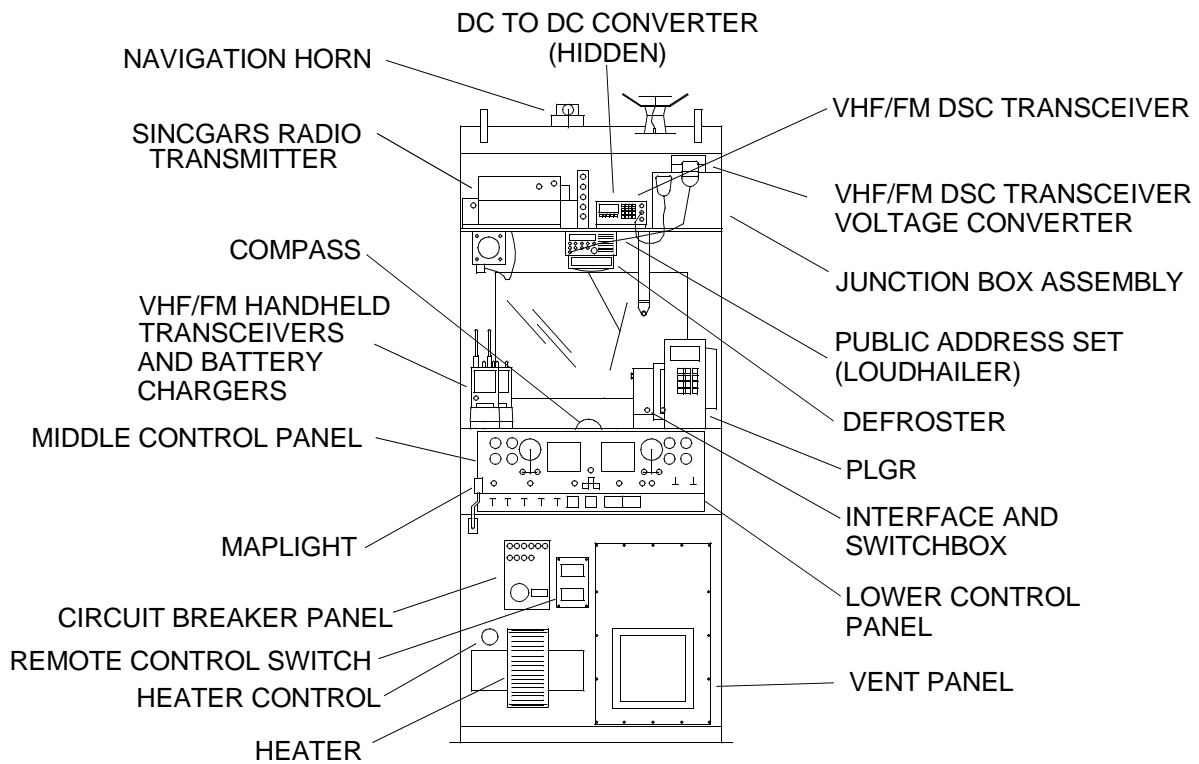
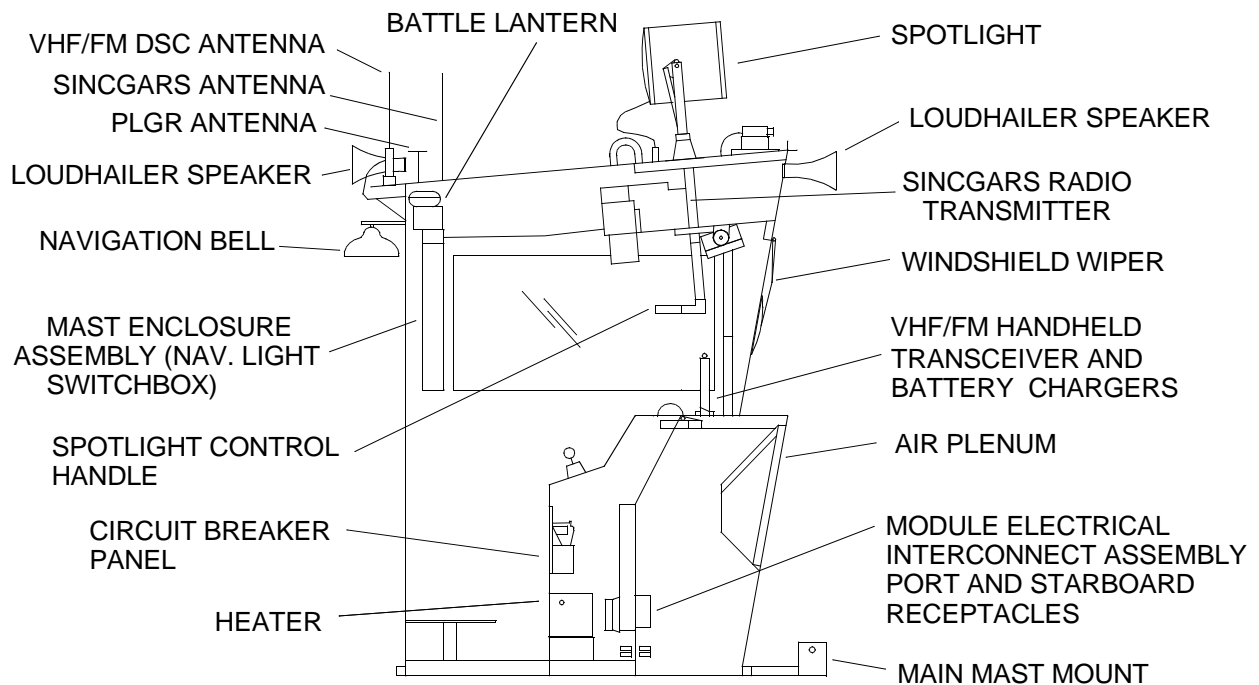
The operators cab is a portable steel fabricated unit which can be mounted on either the port or starboard propulsion module. It houses the following: middle control panel A1, lower control panel A2, operators cab circuit breaker panel A3, mast enclosure assembly A7, navigation light switch box containing controls and indicators for the main mast (primary and secondary), a battle lantern and a magnetic compass. A module electrical interconnect assembly is the electrical control link that allows control of both propulsion modules from the operators cab. The receptacles for the interconnect assembly are located within an operators cab access panel and intake plenum access panel

Communications and electronic equipment required to operate the CF include the VHF/FM DSC (Digital Selective Calling) transceiver programmable with weather channel, VHF DSC transceiver voltage converter, AN/VRC-88D SINGARS radio transmitter, two VHF/FM handheld transceivers with hands free capability and their associated battery chargers, public address set (loudhailer), AN/PSN-11(V)1 precision lightweight global positioning receiver (PLGR), AN/PSN-11 PLGR interface and switchbox and a DC to DC converter.

The following items are located on top of the operators cab: antennas for the VHF/FM DSC transceiver, AN/PSN-11(V)1 PLGR, AN/VRC-88D SINGARS radio transmitter, along with a navigation horn, forward and aft public address set (loudhailer) hailer horns and a 12 in. diameter 24 VDC marine duty spot light. The spotlight is controlled by a manual remote lever, which penetrates through the operators cab. An electric toggle switch in the middle control panel A1 activates the spotlight.

The operators cab contains an electrically powered heater and defroster with independent controls for each.

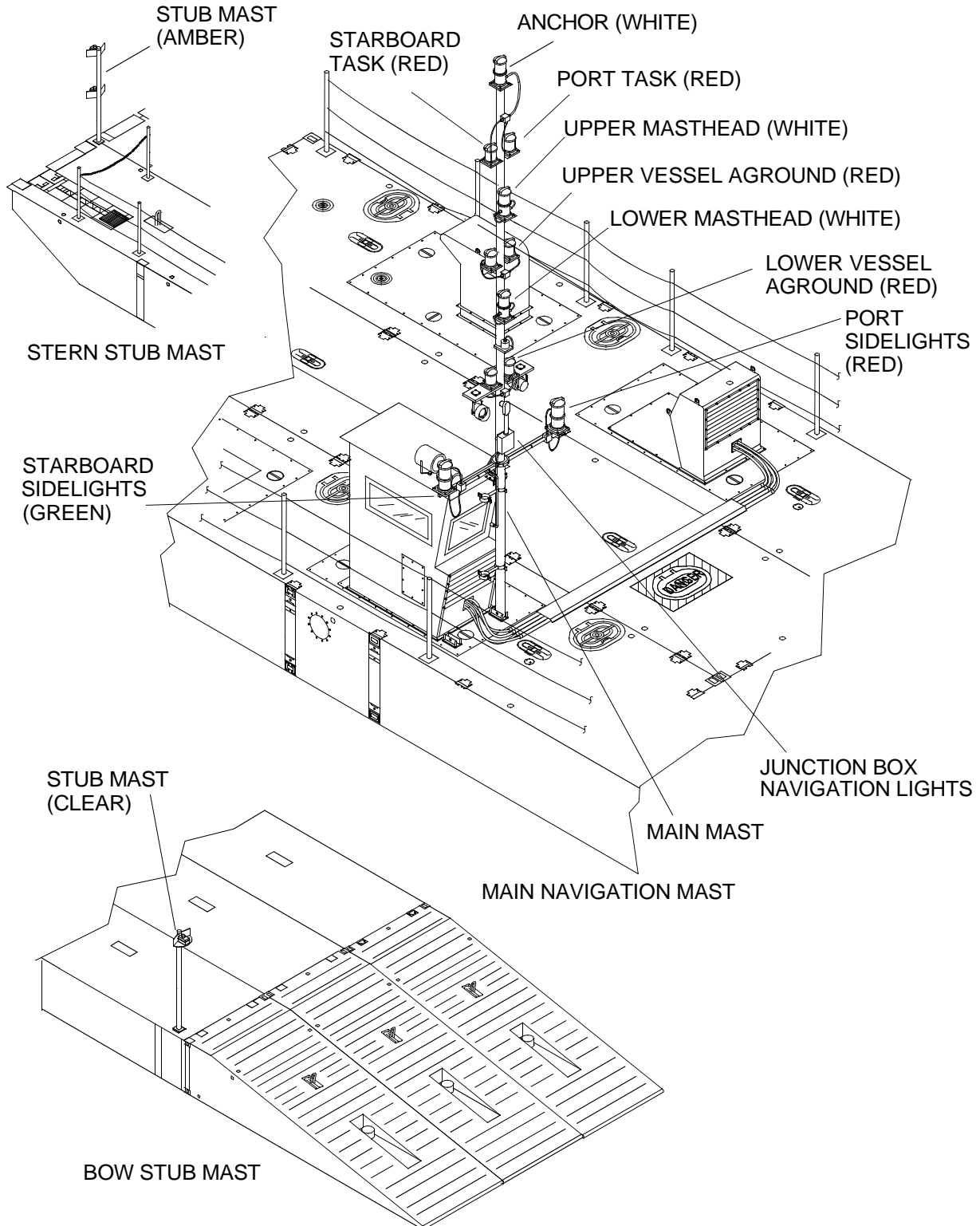
The receptacles for the interconnection cables to operate both propulsion modules from one set of controls are located within the cab. The main navigational mast mounting clamps and supports are externally mounted to the cab. Miscellaneous cab equipment includes a windshield wiper.



OPERATORS CAB

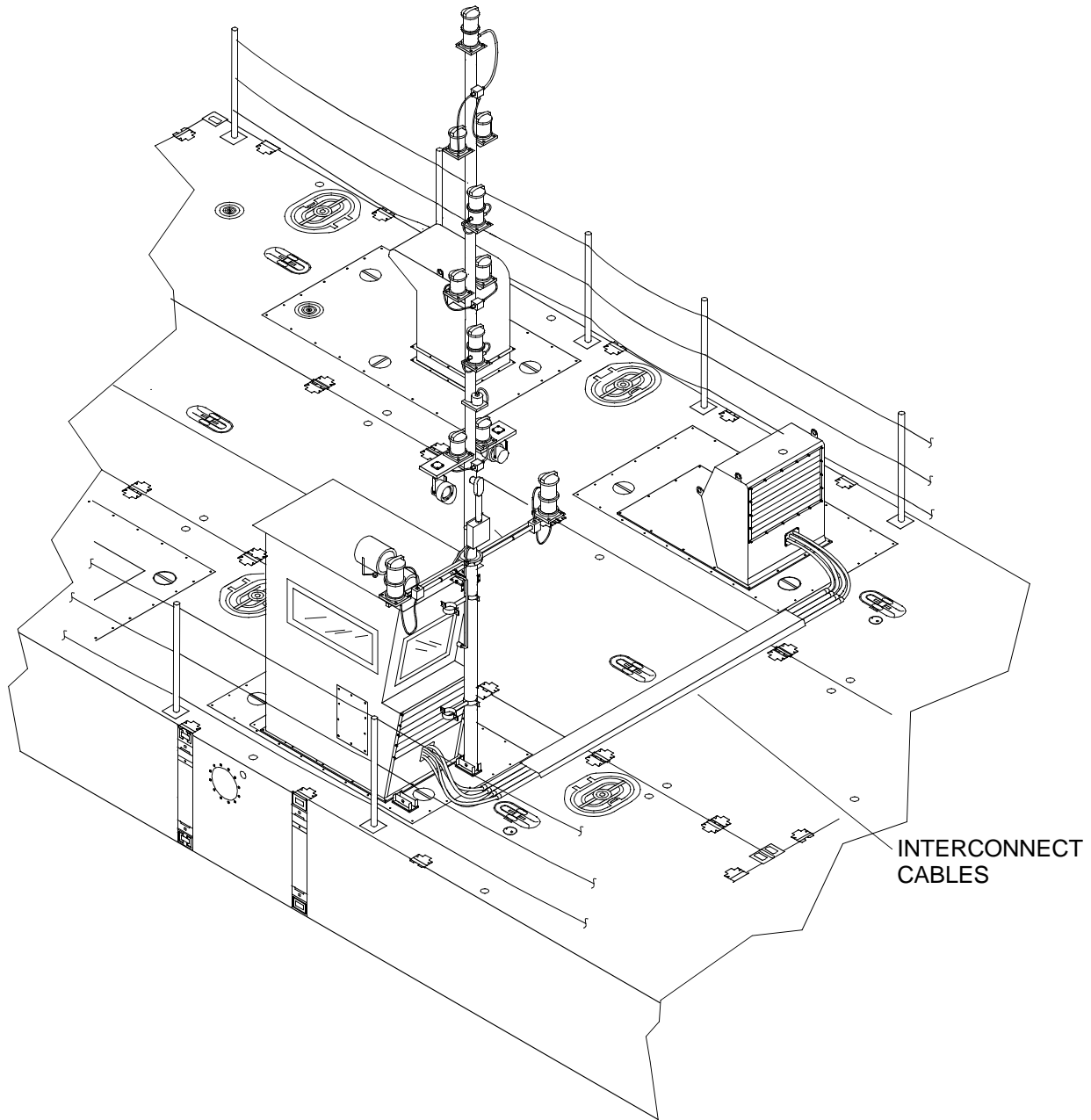
NAVIGATION LIGHTS

The main navigational mast is mounted on the front and to the inboard side of the operators cab, the bow stub mast is mounted on the forward starboard side of beach sea end section end rake and the stern stub mast is mounted on the aft end of the CF. These masts provide the necessary navigational running lights for signal and safety while the CF is in operation.



MODULE ELECTRICAL INTERCONNECT CABLES

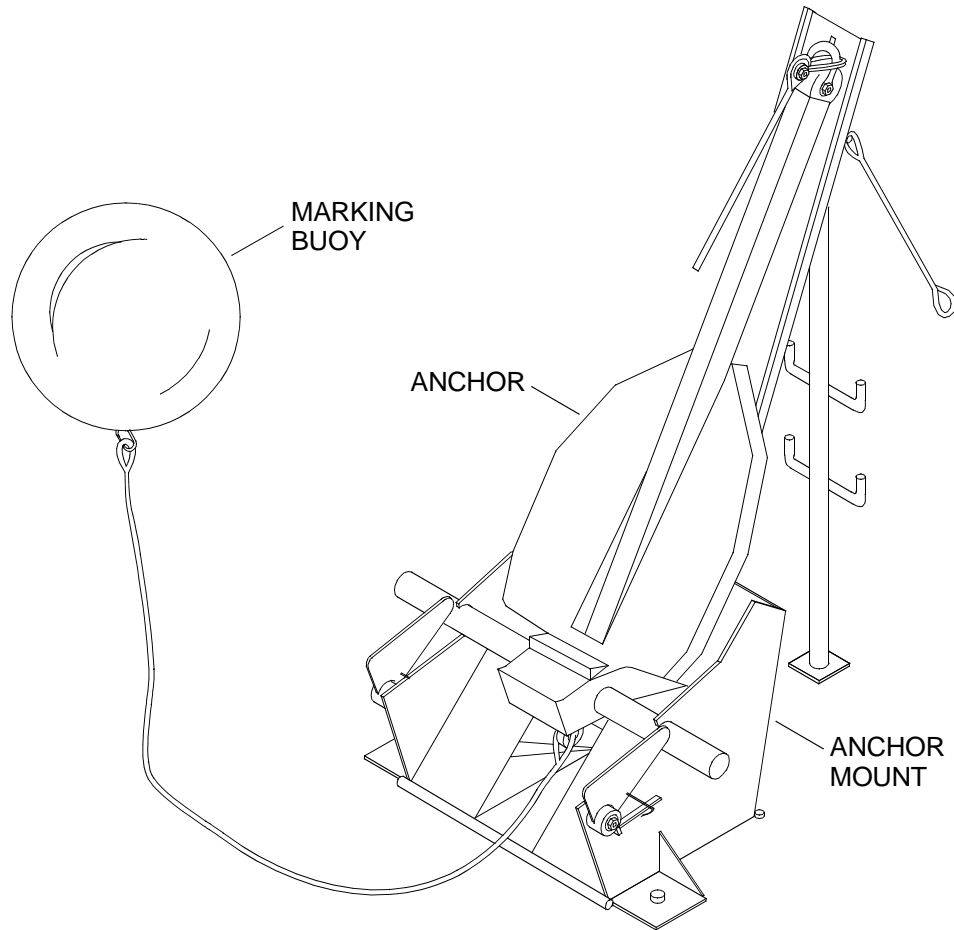
The two propulsion modules are linked together with a reinforced and hardened set of interconnect cables. The interconnect cable allows operation commands to be transmitted from the operators cab to both propulsion module engines and pump-jet thrusters. The interconnect cable is connected to the receptacles located in front of the operators cab and front of the intake plenum on the opposite propulsion module.



MODULE ELECTRICAL INTERCONNECT CABLES

ANCHORBOARD

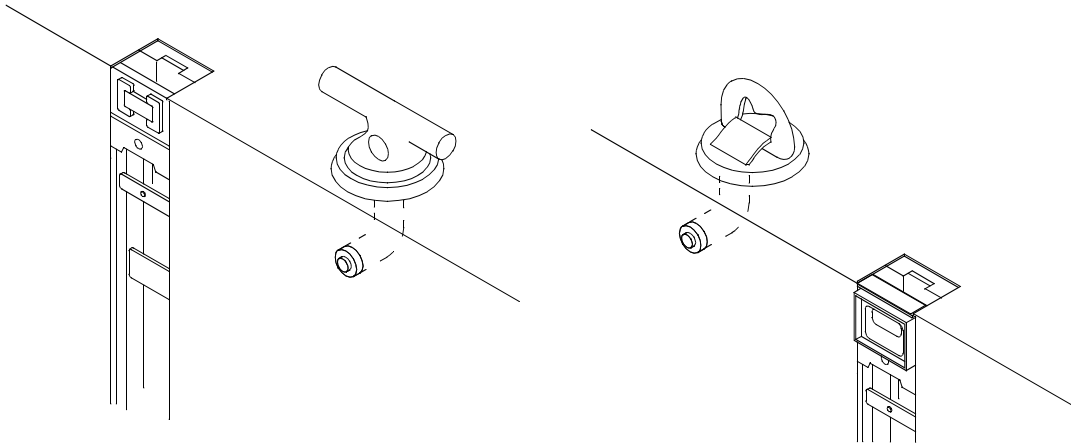
A 3,500 lb emergency anchorboard assembly is mounted on the starboard propulsion module. When losing power or an emergency situation causes the CF to lose steering or become inoperative the 1,500 lb anchor, with a marking buoy attached, can be manually deployed by the crew. When the inoperative CF becomes operational or is towed away, the crew disconnects the anchor from the CF. The buoy marks the location of the anchor for retrieval by another watercraft.



ANCHORBOARD ASSEMBLY

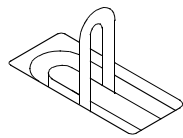
DECK FITTINGS

CF assemblies are provided with deck fittings to meet various operational needs. Available fittings include deck cleats and a combination D-ring/cloverleaf. These fittings have a 15,000 lb load capacity. There are 10 tube turns, for installing the deck fittings, on each center and propulsion modules and five on the end rakes. The CF modules are provided with recessed lift shackles welded into the deck structure. The propulsion module lift shackles have a safe working load capacity of 35 tons. The center and end rake modules lift shackles have a safe working load capacity of 25 tons. There are two shackles per center and propulsion module and one on the end rake. When stowed, the shackles fold down flush with the deck. The rhino horn is used when the CF needs to be mated to Army/Navy Lighters (NL).

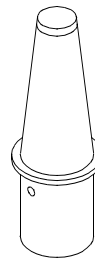


DECK CLEAT

CLOVERLEAF/D-RING



LIFT SHACKLE



RHINO HORN

DECK FITTINGS

**OPERATOR MAINTENANCE
CAUSEWAY FERRY
DESCRIPTION AND DATA**

EQUIPMENT DATA

The following tables provides data applicable to major component levels.

■ **Table 1. CF Equipment Data.**

ITEM CHARACTERISTIC	DESCRIPTION
CAUSEWAY FERRY SYSTEM	
Length	329 ft with P3 adaptor
Beam	24 ft
Depth	4 ft 6 in.
Freeboard (Unloaded)	40 ± 2 in.
Freeboard (Loaded)	12 ± 2 in.
Weight (Unloaded)	226 tons
Weight (Fully Loaded)	576 tons
Maximum Speed	6 knots, Sea State 2
Cargo Capacity	350 short tons
Fuel Tank Capacity (Each)	800 gallons (400 gallons per tank)
POWERED SECTION	
Length	80 ft
Beam	24 ft
Depth	4 ft 6 in.
Freeboard (Unloaded)	40 ± 2 in.
Freeboard (Loaded)	12 ± 2 in.
Weight	86 tons dry, 87.9 tons wet
ISO Compatible	Yes
Sea State Operation	SS 2
Engine (2 Per Section)	8V92TA 2 cycle, diesel
Rated Horse Power (Each)	600 hp at 2,100 RPM at output shaft
Cylinders	Qty 8
Starting System	24 volt electric
Fuel Capacity	800 gallons (400 gallons per tank)
Average Operating Time Per Tank Of Fuel	10 hours

Table 1. CF Equipment Data. (Continued)

ITEM CHARACTERISTIC	DESCRIPTION
Marine Gear	Twin Disc Model DD-5111V
Pump-Jet (2 Per Section)	Model SPJ-82-T
Pump-Jet Output (Each)	5,000 lbs horizontal thrust at ship's speed of 6 knots
Steering	360°
Total Thrust	10,000 lbs at 2,100 engine RPM
Electrical System	24 volt 220 amps
Bilge Pumps	12 each at 3,700 GPH
Fire Suppression System	Manually Activated CO2
INTERMEDIATE SECTION	
Length	80 ft
Beam	24 ft
Depth	4 ft 6 in.
Freeboard (Unloaded)	40 ± 2 in.
Freeboard (Loaded)	12 ± 2 in.
Weight	67.5 tons
ISO Compatible	Yes
Sea State Operation	SS 2
BEACH END SECTION	
Length	85 ft
Beam	24 ft
Depth	4 ft 6 in.
Freeboard (Unloaded)	40 ± 2 in.
Freeboard (Loaded)	12 ± 2 in.
Weight	77.6 tons
ISO Compatible	Yes
Sea State Operation	SS 2

Table 1. CF Equipment Data. (Continued)

ITEM CHARACTERISTIC	DESCRIPTION
P-3 ADAPTOR ASSEMBLY	
Length	3 ft 2 in.
Beam	8 ft
Depth	4 ft 6 in.
Weight	5 Tons
ISO Compatible	No
Sea State Operation	SS 2
CENTER MODULE	
Length	40 ft
Beam	8 ft
Depth	4 ft 6 in.
Weight	11.25 Tons (approximate)
ISO Compatible	Yes
Sea State Operation	SS 2
END RAKE MODULES	
Length	20 ft
Beam	8 ft
Depth	4 ft 6 in.
Weight	6.25 Tons (approximate)
ISO Compatible	Yes
Sea State Operation	SS 2

**OPERATOR MAINTENANCE
CAUSEWAY FERRY
THEORY OF OPERATION**

SYSTEM OPERATION

Operation of the CF revolves around the diesel engine (power) and the pump-jet for movement and direction. When the diesel engine is running, the marine gear engages the transfer case into gear, which changes the engine speed to shaft speed. Seawater is brought into the pump-jet through the inlet grating at relatively low velocity in order to minimize ingestion of debris. Seawater travels through the heliconic converter at high head and moderate velocity, thus reducing losses due to turbulent flow. Seawater then flows through the discharge port, which contains a hydraulically actuated, specially designed steering nozzle. The accelerated water mass provides a reactive force acting on the hull of the vessel. Direction is controlled by rotation of the steering nozzle. Thrust is increased or decreased by varying the speed of the diesel engine. Control and indicators necessary to operate the pump-jet are located in the operators cab. The following paragraphs provide the theory of operation of the CF subsystems.

DRIVE TRAIN

The drive train consists of the engine, marine gear, transfer case and pump-jet. Guarded drive shafts connect the marine gear to the transfer case and the transfer case to the pump-jet.

Engine

The engine is an 8 cylinder, water cooled, turbo charged, after cooled, two cycle, diesel marine engine, delivering 600 hp at 2100 RPM. Control of the engine is accomplished from the operators cab.

Marine Gear

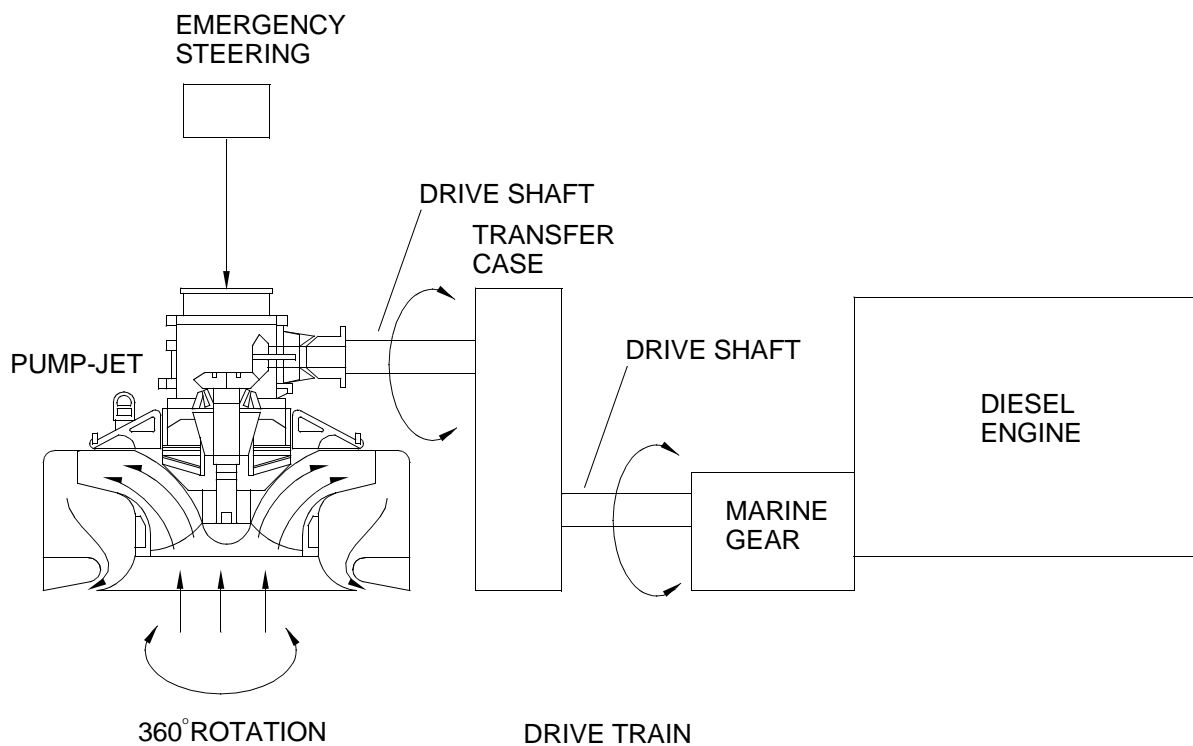
The marine gear is mounted directly to the flywheel housing of the diesel engine and provides the capability to reverse the directional rotation of the other drive train components, making it possible to backflush the pump-jet. The transmission is equipped with an integral hydraulic system consisting of a pump, shifting valve and internal hydraulic cylinders. The pump utilizes the transmission lubricating oil to operate hydraulic cylinders, which shifts the gears to the backflush, neutral or engaged configurations. The shifting valve is solenoid actuated from a toggle control switch in the operators cab. In addition to powering the shifting cylinders, the pump also circulates case oil through an oil cooler that is cooled by the engine raw water cooling system. In the event of electrical power loss to the marine gear shifting solenoids, an emergency engagement capability is provided for the marine gear by replacing a shifting valve solenoid with an emergency lock-up plug that locks the marine gear. The lock-up plug is used to provide independent forward or backflush capabilities and is mounted externally to the shifting valve solenoid housing.

Transfer Case

The transfer case compensates for offset alignment between the output flange of the marine gear and the input flange of the pump-jet. It has a 1:1 gear ratio, utilizing spur gears throughout and is equipped with an oil pump that circulates lubricating oil from its gearcase through an oil cooler that is cooled by the engine raw water cooling system and back to the top of the transfer case to lubricate the upper gearing. The transfer case is connected to the marine gear and pump-jet via drive shafts.

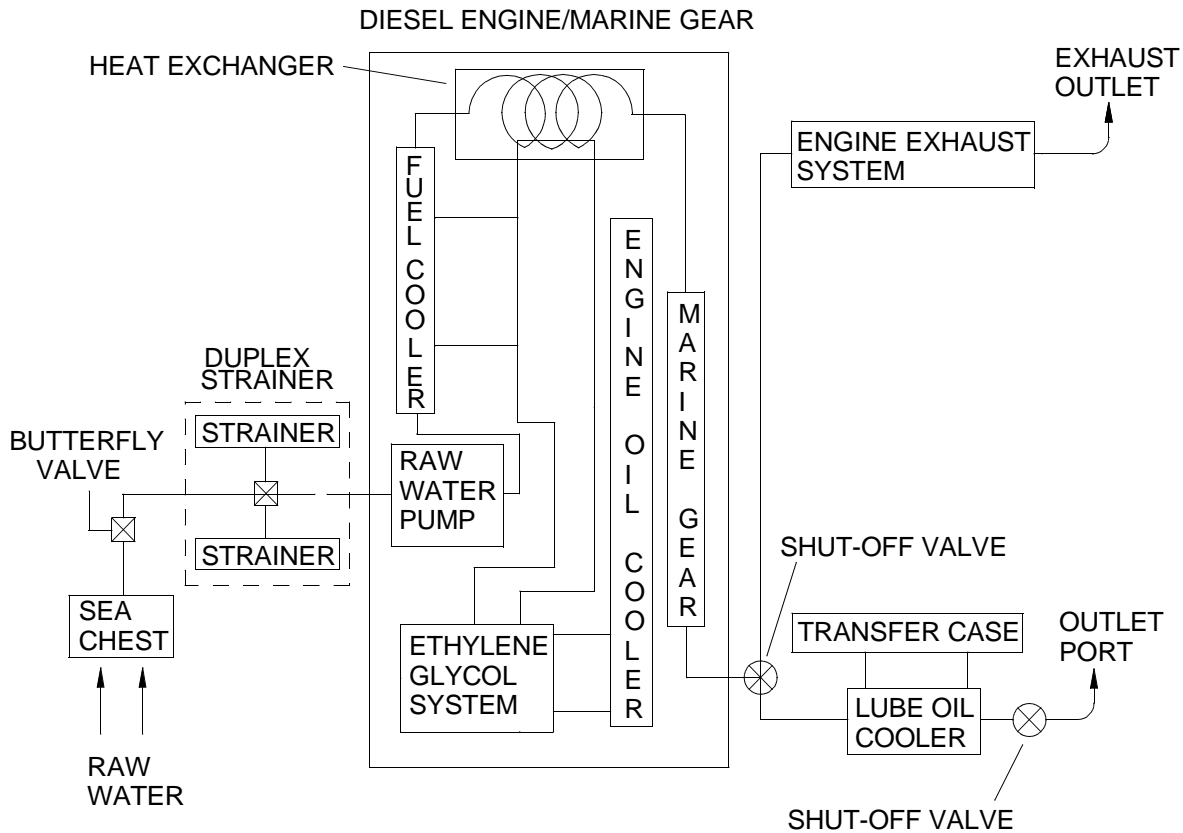
Pump-Jet

Each propulsion module is equipped with a 360° steerable pump-jet propulsion unit capable of delivering 5,000 lb of thrust. The pump-jet works on the principal of a rotary pump and consists of a drive shaft that drives an upper gearbox assembly that drives an impeller. Water is sucked into the pump-jet through a feeding funnel on the bottom of the module and fed into the enclosed pressure casing, whose bottom plate is provided with three systematically arranged outlet nozzles from which water is ejected at a 13° angle. A hydraulic steering motor drives a spur gear through a planetary gearbox to rotate the pressure casing and bottom plate (steering nozzles) in both senses of rotation without limitation. A second planetary gearbox is provided to facilitate emergency steering. The emergency steering control stand is mounted above deck and interfaces with the through shaft of the planetary gearbox. The emergency steering gearbox contains a spring set, hydraulically released disc brake. The brake maintains the position of the steering nozzle until rotation is called for by the operator. In the event of hydraulic system failure, the brake can be released via the hydraulic hand pump to facilitate emergency steering. An electromechanical feedback unit monitors relative steering position of the steering nozzle and transmits that position to a dial indicator in the operators cab. An electric sensor monitors the oil level in the upper gearbox and sends a signal to an indicating light in the operators cab when the oil level is below the required level.



COOLING AND EXHAUST (SEA WATER) SUBSYSTEM

The engine and exhaust system consists of the seachest (raw water inlet, integral with the structure of the module), butterfly valve, duplex strainer, engine raw water pump, aftercooler, fuel cooler, engine coolant heat exchanger, marine gear oil cooler, exhaust water shutoff valve, transfer case oil cooler, transfer case shut-off ball valve, water cooled muffler and exhaust flappers. The water cooling system dissipates heat generated by the diesel engine, engine exhaust, marine gear and transfer case. This is accomplished by circulating raw (sea) water through the engine raw water pump, engine heat exchanger, marine gear oil cooler, transfer case oil cooler and muffler. The system is an open loop, drawing naturally cool sea water in one side and discharging heated sea water out of the other in a continuous cycle. The process requires the interaction of the following five subsystems.



COOLING SYSTEM SCHEMATIC DIAGRAM

Raw Water (Sea Water) Subsystem

An engine driven raw water pump draws sea water from the sea chest in the bottom of the hull through a duplex strainer to a heat exchanger at the front of the engine. A fuel cooler is located in the raw water system between the raw water pump and the heat exchanger. Fresh water (ethylene glycol) cooling lines are passed through the heat exchanger. The raw water circulates around the engine coolant lines, lowering the temperature of the ethylene glycol coolant. Raw water exiting the heat exchanger is channeled through the marine gear oil cooler. Raw water from the marine gear oil cooler is then channeled in two directions. A portion of the water is piped into the exhaust inlets to the muffler, cooling the muffler and exiting the module via the thru hull assembly. The remaining water is piped through the transfer case lube oil cooler and exits the module via an outlet port.

Fresh Water (Ethylene Glycol) Subsystem

Coolant is drawn by the engine water pump from the heat exchanger and is circulated through the fuel cooler, engine lube oil cooler, cylinder block, cylinder heads and exhaust manifolds to the thermostat housings. A bypass from the thermostat housings to the inlet side of the water pump permits circulation of coolant through the engine when thermostats are closed. When the thermostats are open, the coolant flows through the heat exchanger where it is cooled. Thermostats control and regulate the flow of coolant within the fresh water cooling system to control engine temperature.

Marine Gear Oil Cooler

Raw water exiting the engine heat exchanger passes through the marine gear lube oil cooler. A gear pump, integral to the marine gear, circulates case oil from the marine gear through external lines to a heat exchanger type oil cooler and back to the transmission. Seawater passing through the oil cooler is circulated around the heat exchanger, lowering the temperature of the lube oil. The bearings, clutches and gears are lubricated and cooled by the returning lube oil.

Water Cooled Muffler

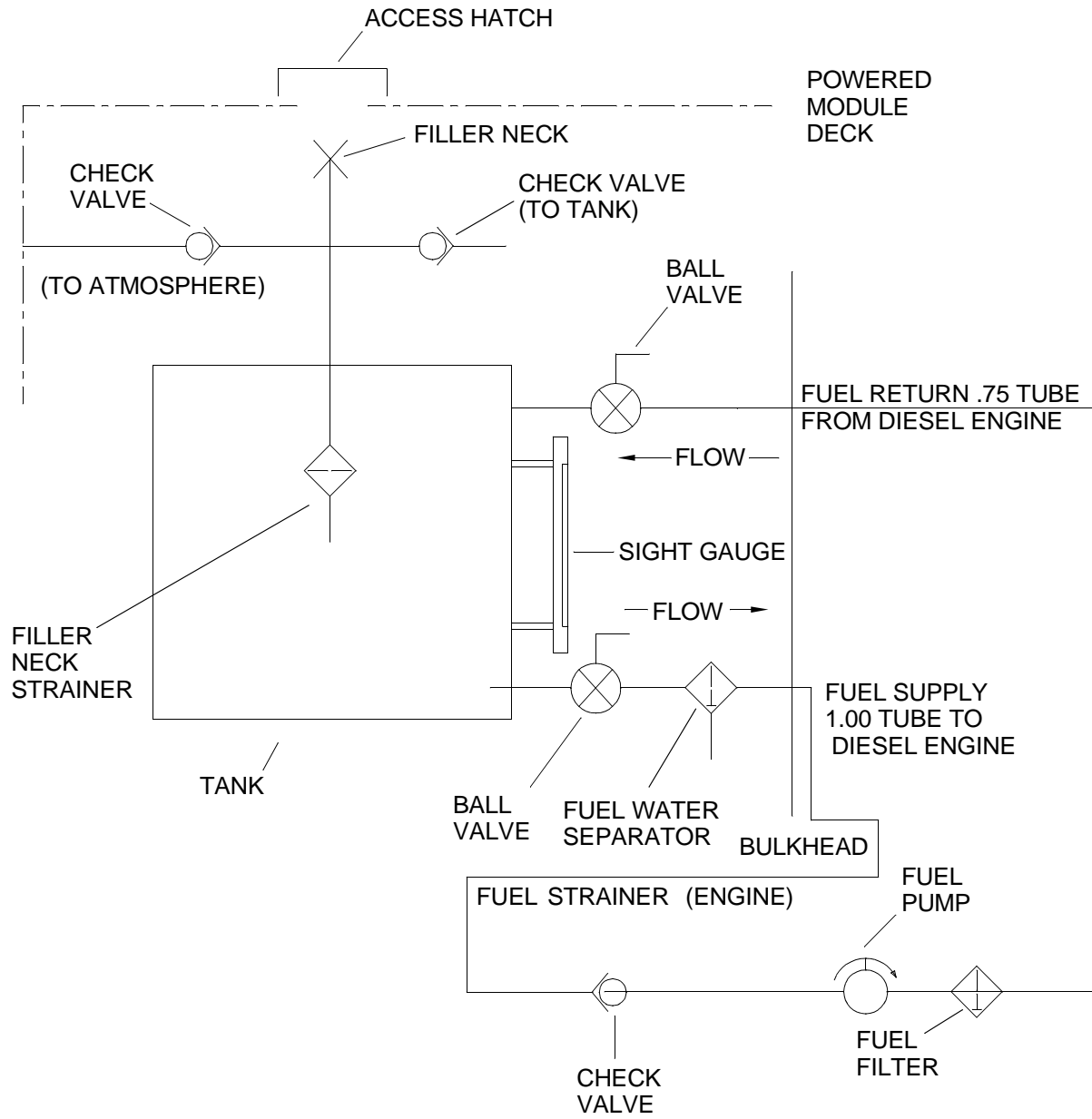
A normally open ball valve allows raw water exiting the marine gear oil cooler to be pumped into the exhaust system between the turbo chargers and the muffler, filling the muffler with water and cooling prior to being expelled through the exhaust flapper port with the engine exhaust fumes. In addition to cooling the muffler, the water also acts as a noise dampening media within the muffler itself.

Transfer Case Lube Oil Cooler

A normally open ball valve allows raw water exiting the marine gear oil cooler to be pumped through the transfer case oil cooler. A gear driven pump, operated by rotation of the transfer case gearing, circulates lube oil from the transfer case through external lines to the heat exchanger type transfer case lube oil cooler and back to the transfer case. Seawater passing through the heat exchanger cools the lube oil. The cooled oil is returned to the top of the transfer case, lubricating the upper gears and bearings and cooling the unit simultaneously.

FUEL SYSTEM

The fuel system provides a filtered fuel supply to the diesel engine and is identical for port and starboard propulsion modules. A fabricated steel fuel tank stores 400 gallons of diesel fuel. The level of fuel in the tank can be viewed through a sight gauge located on the side of the tank. Fuel is added to the tank through a filler neck and filtered through a mesh strainer and plug, located on the top of the tank. The filler neck is accessible from the deck of the propulsion module through an 8 in. hatch. During refueling, air is vented from the tank through a check valve. Another check valve allows air to be drawn into the fuel tank as fuel is consumed. Fuel supply and return lines are sized to reduce fuel line pressures. During operation, fuel flows out of the tank through a 1 in. diameter fuel supply line to a fuel/water separator to remove water (condensation or other moisture) from the fuel. Fuel then travels through the supply line and is drawn through a secondary fuel filter mounted on the engine before entering the inlet fuel manifold, then through the fuel pipes to the inlet side of the fuel injectors. Surplus fuel returns from the outlet side of the fuel injectors to the fuel return manifold and then back to the fuel tank through a 0.75 in. diameter fuel return line. A fitting in the fuel outlet manifold in one of the cylinder heads maintains fuel system pressure. A check valve in the supply line prevents fuel from draining back to the tank when the engine is not running. Ball valves are provided on the supply and return lines to shut off the flow of fuel during maintenance and when the CF is not in operation.



FUEL SYSTEM SCHEMATIC DIAGRAM

VENTILATION SYSTEM

The ventilation system draws outside air and directs it below deck around the engine and other propulsion module components, removing heat and toxic fumes aft to be expelled to the atmosphere through the exhaust plenums. In addition, the intake plenum flapper door closes when the fire suppression system is activated, shutting off the supply of air to the machinery compartment. A secondary purpose of the system is to provide service access to the components below deck through large, removable deck covers. The CF ventilation system is comprised of the following components and operating mechanisms listed below.

Air Intake Plenum

The air intake plenum accepts outside air and directs it below deck to the machinery compartment. It is mounted on the engine hatch of the propulsion module facing forward. The plenum may be located on either the port or starboard side, depending on placement of the operators cab for that section. An air intake plenum is built into the front of the operators cab. The intake plenums also include the conduit entry plates for the electrical interconnect when the propulsion modules are assembled into a powered section.

Air Intake Plenum Flapper Door (Damper)

The intake plenum contains a flapper door which works in conjunction with the fire suppression system. A wire rope, (attached to the flapper door within the intake plenum) is released when the fire suppression system is activated. This allows the flapper door to fall due to its own weight and rotate about 45° downward, closing the door and preventing oxygen from feeding a fire within the machinery compartment of the propulsion module.

Ventilation Fan (Exhaust Fan)

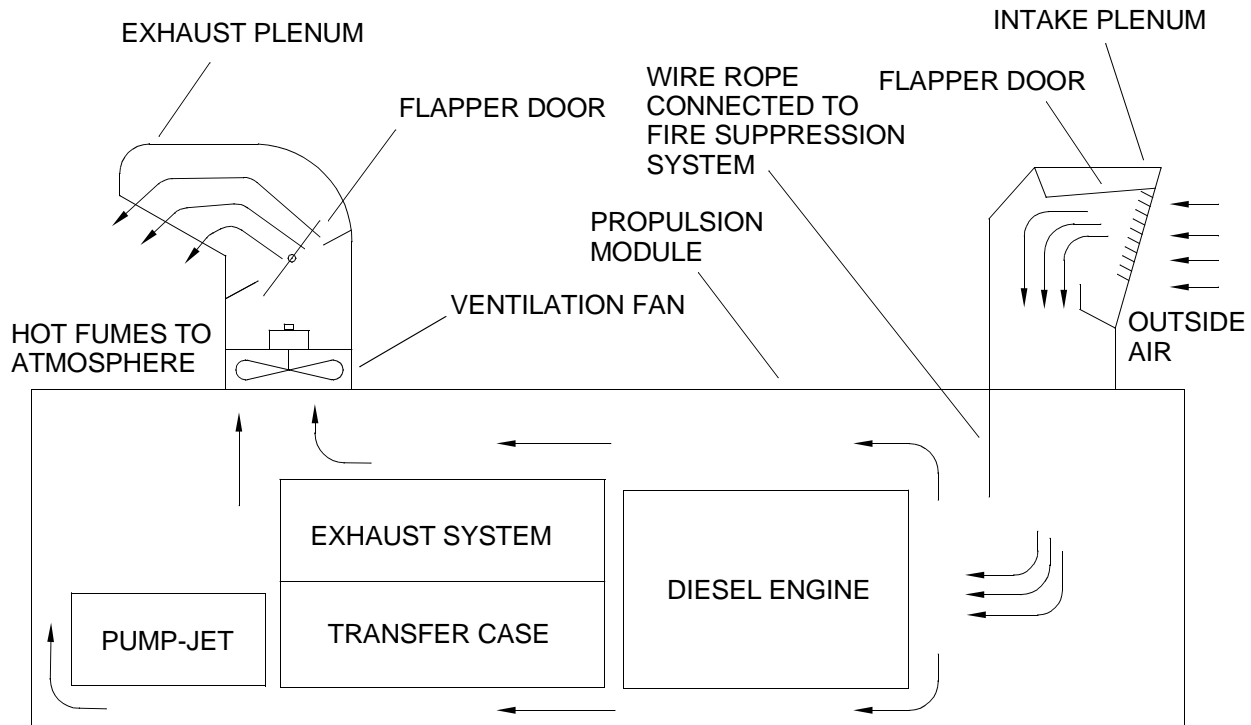
A ventilation fan draws hot fumes from below deck within the machinery compartment of the propulsion module. The blower moves air through the exhaust plenum at 3,075 cubic ft per minute. It removes heat from the engine, pump-jet and drive train components, forcing the hot fumes above deck and expelling them to the atmosphere. The marine duty 18 in. inner diameter ventilation fan has a cast aluminum alloy fan and is located at the intake side of the exhaust plenum. The blower has a ¾ hp, 24 VDC motor and runs at 1,750 RPM. Under normal operating conditions, the blower is controlled from a toggle switch located in the operators cab. If the fire suppression system is activated, power to the blower is disconnected automatically.

Exhaust Plenum

A welded metal structure, the exhaust plenum contains a ventilation fan and a flapper door. It is mounted on the thruster hatch of the propulsion module facing aft and provides ventilation for the machinery compartment of the propulsion module. A ventilation fan at the intake end of the plenum draws air from below deck, creating a vacuum which draws air through the intake plenum and expels hot, toxic fumes to the atmosphere.

Exhaust Plenum Flapper Door (Damper)

A hinged flapper is housed within the plenum. It is manually opened and closed. If the fire suppression system is activated, the flapper has to be closed manually, eliminating a second source of air to any fire below deck.



VENTILATION SYSTEM FUNCTIONAL DIAGRAM

CF ELECTRICAL SYSTEM

The CF propulsion units are supplied with a 24 VDC main power source which consists of six batteries that are located within the powered module. This provides power to the engine starter solenoid, alternator and operating systems. The main power source is charged from the engine alternator system via the voltage regulator. The voltage regulator uses alternator and battery temperature sensors. The sensors signal the voltage regulator for monitoring and balancing over-temperature conditions by reducing field output. The voltage regulator allows control of field output at the field wire which can be used in warmer operating areas. This system will also assist in minimizing belt slippage. The propulsion units are also equipped with an auxiliary 24 VDC power supply that is used to operate the pump-jet thruster indicator directional system. The two 12 VDC auxiliary batteries are also charged from the engine alternator via the isolator located on the A10 panel. The auxiliary battery system provides power in case the main 24 VDC power source fails. The main power source provides power to the propulsion module circuit breaker panel A6 and to the 50 amp breaker (located on the A10 panel) for distribution to the propulsion module and operators cab electrical systems. The power cables feed from the propulsion module through the electrical interconnection box up to the cab. The propulsion module has a multi-battery isolator that allows for all six batteries to be paralleled for emergency starting of the engine. A remote switch is located inside the operators cab that allows the operator to parallel the batteries.

Ventilation

Both port and starboard units are equipped with a ventilation system. This system circulates outside air from the intake plenum through the engine compartment and out the exhaust plenum. The ventilation system is operated by a blower equipped with a ¾ hp, 24 VDC motor. The unit is powered by the 24 VDC main power system, main circuit breaker, CO2 pressure switch, operator switch and vent fan relay enclosure A8K1 relay.

Bilge Flood Warning and Control System (Port or Starboard)

The system is powered by the main 24 VDC power source. The power is fed through the propulsion module circuit breaker panel A6 to the bilge pump control panel A5 and single bilge pump control panel A7 up to the cab control. The float switches provide the signal to the cab control that allows the operator to hear the alarm and check the red activated indicator(s) for location of flooding. The alarm silence switch should also be activated. The pump run switch provides power to the pump start relay contacts that start the pump and activates the green indicating lamp.

Communications

AN/VRC-88D SINGGARS RADIO. The AN/VRC-88D SINGGARS radio receives 24 VDC power from the main power system via the cab circuit breaker panel. The signal output of the transmitter is generated from the outdoor antenna.

VHF/FM DSC TRANSCEIVER. The VHF/FM DSC transceiver receives 12 VDC power from the main power system via the VHF/FM DSC transceiver voltage converter. This circuit is protected by an in line 10 amp fuse that is fed through a ferrite line interference conditioner from the cab circuit breaker panel. The signal output of the transceiver is generated from the transceiver antenna.

VHF/FM HANDHELD TRANSCEIVER. The VHF/FM handheld transceiver receives its power from a self-contained, replaceable and rechargeable nickel-cadmium battery pack. The battery packs are recharged by battery chargers. The battery chargers receive 12 VDC power from the main power system via the DC to DC converter.

PUBLIC ADDRESS SET (LOUDHAILER). The loudhailer receives 12 VDC power from the main power system via the DC to DC converter.

VHF/FM DSC TRANSCEIVER VOLTAGE CONVERTER. The 24 VDC to 12 VDC voltage converter receives 24 VDC power from the main power system and reduces the voltage to 12 VDC to power the VHF/FM DSC transceiver.

DC TO DC CONVERTER. The 24 VDC to 12 VDC voltage converter receives 24 VDC power from the main power system and reduces the voltage to 12 VDC to power the loudhailer, interface and switchbox and VHF/FM hand-held transceiver battery chargers.

AN/PSN-11 INTERFACE AND SWITCHBOX. The AN/PSN-11 interface and switchbox receives 12 VDC power from the main power system via the DC to DC converter.

AN/PSN-11(V)1 PRECISION LIGHTWEIGHT GLOBAL POSITIONING RECEIVER (PLGR). The AN/PSN-11(V)1 PLGR receives 12 VDC power from the AN/PSN-11 interface and switchbox.

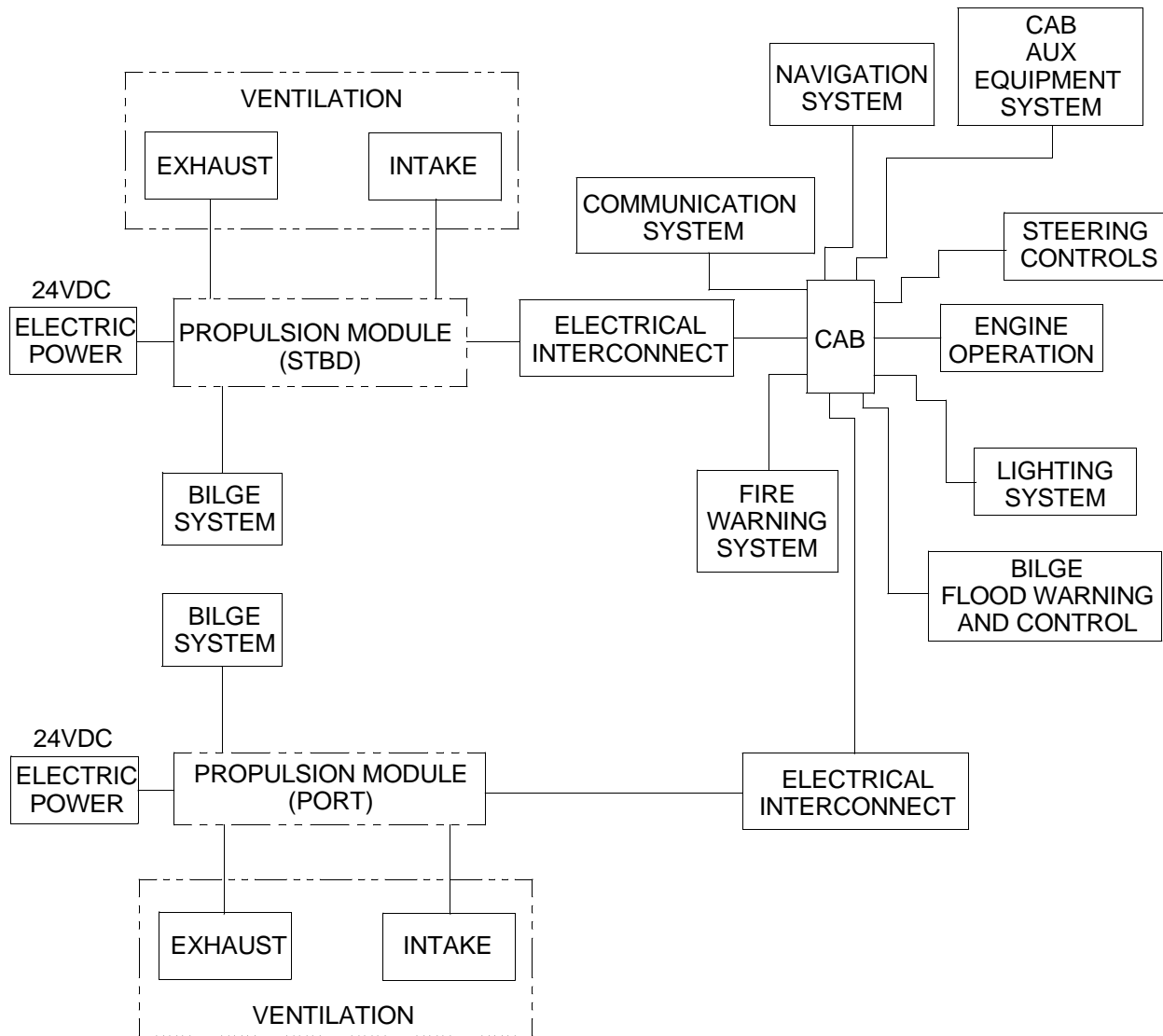
Navigation System

NAVIGATION LIGHTS. The main mast navigation lights receive 24 VDC power from the main power system via the cab circuit breaker panel A3 through the mast enclosure assembly A7. The enclosure contains the switches, warning lights and alarm system for controlling the main mast lights. The stub mast lights are self-contained and powered by 6 volt batteries.

HORN. The outside horn receives 24 VDC power from the main power system via the cab circuit breaker panel A3 and the operator control pushbutton on the middle control panel A1.

COMPASS. The compass combined with a digital heading sensor provides navigation direction. The compass has automatic compensation and an LCD readout displays heading in digits as well as in cardinal points. The compass can be changed from compass rose to graphic steering indicator and has 10 levels of damping.

SPOTLIGHT. The spotlight receives 24 VDC power from the main power system via the cab circuit breaker panel A3 and the operator control switch on the middle control panel A1.



CF ELECTRICAL BLOCK DIAGRAM

Engine Operation (Port and Starboard)

The engine receives 24 VDC power from the main power system that operates the engine starter motor, starter contact B1, and engine starter solenoids L3, which is activated by a “K” relay-operator control. During cold weather conditions (-25°F or less), an engine cold pack starting aid automatically supplies ether into the air inlet housing of the blower. In case of extreme cold weather starting conditions, the engine power system is also equipped with a NATO jumper cable receptacle. The engine contains the following operation switches of sending units that provide signals to the operator controls listed below.

FUEL OIL PRESSURE SWITCHES. The fuel oil pressure switches provide signals to the operator console for starting or stopping of the engine.

LOW OIL PRESSURE SWITCH. The low oil pressure switch provides a signal to the operator console to activate the “K2” relay that activates the engine alarm bell and light.

HIGH WATER TEMP SWITCH. The high water temp switch provides a signal to the operator console to activate the “K2” relay that activates the engine alarm bell and light.

WATER TEMP SENDING UNIT. The water temp sending unit provides a signal to the operator console for engine water temperature readout.

OIL TEMP SENDING UNIT. The oil temp sending unit provides a signal to the operator console for engine oil temperature readout.

OIL PRESSURE SENDING UNIT. The oil pressure sending unit provides a signal to the operator console for engine oil pressure readout.

ENGINE NORMAL STOP PUSHBUTTONS. The engine normal stop pushbuttons disconnect the 24 VDC signal to the governor controller that will stop the engine under normal conditions.

ENGINE HOUR METER. The engine hour meter receives 24 VDC power from the main power system and is energized when the fuel oil pressure switch is closed, the engine power switch is turned on and the circuit breaker switch is activated.

Engine Alternator

The engine alternator provides power to recharge the main battery and auxiliary battery systems. It is controlled by the voltage regulator located on and distributed through the A10 panel. The alternator also provides a signal to the operator console for the engine RPM/tachometer readout. The alternator and batteries have a temperature sensor that provides a signal to the voltage regulator to prevent overheating of the alternator and batteries. The operator’s console ammeter(s) indicate the system batteries charge and discharge in amps.

Electronic Speed Switch

The electronic speed switch provides a signal to the system via the engine magnetic pick-up. This system activates the emergency stop circuit by energizing the air flap solenoid, tripping the air flap closed when the engine RPM exceeds 2,300 RPM. The power source is 24 VDC power from the main power system operated through the fuel oil pressure switch from the main breaker.

Engine Governor

The engine governor provides a minimum/maximum speed range (800 - 2,100 RPM) for normal engine operation. The power source is 24 VDC power from the main power system operated through the engine power switch on the middle control panel A1 and propulsion module circuit breaker panel A6.

Operator Engine Control, Alarms and Indicator System

The following items extend the engine system for engine operation.

ENGINE GAUGES. The engine gauges receive their signals from the engine and are powered from the fuel oil pressure switch via the main breaker panel and the engine power switch.

ENGINE GAUGES TEST SWITCHES. The engine gauges test switches provide power from the main circuit breaker to the power side of the gauges to activate them during test prior to start-up.

ENGINE POWER SWITCHES. The engine power switches provide power from the main circuit breaker to the engine starting, stopping and fuel oil pressure switch for gauge operation.

ENGINE START SWITCHES. The engine start switches provide power to the engine start relay A1K1 from the main breaker panel through the engine power switch through the clutch deenergized normally closed relay. If the clutch switch is not disengaged from either the engaged forward or backflush positions, the engine will not start.

ENGINE ALARM WARNING/INDICATING SYSTEM. The engine alarm warning/indicating system, upon receiving an alarm from the port or starboard engine high water temp or low oil pressure, will activate an indicating light and bell. At this point, the alarm/silence/test switch can be actuated.

ALARM/SILENCE/TEST SWITCH. The alarm/silence/test switch, when moved from the alarm to the silence position, cuts power to the bell A4LS1 and provides power to the indicating light. When the alarm condition is cleared, the indicating light will go out and the switch can be moved back to the alarm position. The test position will provide power to the bell and the indicating light via the circuit breaker panel. This test position is a monetary contact.

ENGINE THROTTLE CONTROL. The engine throttle control provides a signal to the engine governor that tells the engine to speed up or to slow down. The power source for this control comes from the governor.

MARINE GEAR (FORWARD/DISENGAGED/BACKFLUSH). The marine gear (forward/disengaged/backflush) provides power to shift the gear solenoids. This power comes from the main breaker panel and activates the forward solenoid or backflush solenoid. The engine junction box A4K2 port and A4K3 starboard relays activate an indicating light. If the clutch is left in the forward or backflush position, the engine starting system will not work because the clutch relay contacts in the starting circuit will be open and the engine will not start.

Lighting System

OPERATOR STATIONS. The operator stations middle and lower control panel lights receive 24 VDC power from the main power system via the cab circuit breaker panel A3. The lights are activated by their switch control source and controlled by a dimmer switch. The operation lights used for the gauges are red and require no dimming effect. The operation lights are powered from the same circuit, however the dimmer switch does not affect the operation lights.

CAB SPOTLIGHT. The cab spotlight receives 24 VDC power from the main power system via the cab circuit breaker panel A3 and the operator control switch. The spotlight is used for navigation buoy night identification.

BATTLE LANTERNS. The battle lanterns are powered by six VDC batteries. The cab light has a red lens and below deck lights have white lenses.

Steering (Port and Starboard) Systems

PUMP-JET THRUSTER DIRECTIONAL CONTROL. The pump-jet thruster directional controls are manually controlled joysticks on the operator console, receiving 24 VDC power from the main power system to direct port and starboard pump-jet thrusters. The joysticks move forward and backward only. The system is controlled from the A10 panel circuit breaker through the thruster junction box breaker, which operates the clockwise and counterclockwise rotation relays and contacts K1 and K2 that operate the hydraulic power units thruster solenoids A2jb1-L4 and L5. The reaction speed of the solenoids are controlled by variable resistors A2jb2-R1 and R2.

PUMP-JET THRUSTER DIRECTIONAL INDICATORS. The pump-jet thruster directional indicators receive 24 VDC power from the alternator and the auxiliary 24 VDC battery supply through a voltage regulator located on the A10 panel and is activated by the A9K1 relay contact, which is controlled by the engine starting system. The 24 VDC power to the pump-jet thruster directional signal and indicator has a line converter that stabilizes the 24 VDC power source. The pump-jet thruster directional signal comes from the feed back resistor control.

FIRE ALARM SYSTEM (PORT AND STARBOARD). The fire alarm system (port and starboard) receives 24 VDC power from the propulsion module circuit breaker A6CB4. The circuit is activated by two temperature switches S8 and S9 that send signals up to the operator console and activates the fire alarm horn and warning light. The circuit also has an alarm/silence/test switch which when moved from the alarm to the silence position, cuts power to the alarm horn and provides power to the indicating light. When the alarm condition has cleared, the indicating light will go out and the switch can be moved back to the alarm position. The test position will provide power to the horn and indicating light via the cab circuit breaker panel. This test position is a momentary contact.

Cab Auxiliary Systems

HYDRAULIC OIL LOW LEVEL INDICATOR (PORT AND STARBOARD) UNITS. The hydraulic oil low level indicators (port and starboard units) receive a signal from a float switch sending unit in the hydraulic tank, which provides a signal up to the operator console via the main breaker 24 VDC power system.

PUMP-JET GEARCASE LOW OIL LEVEL INDICATOR. The pump-jet gearcase low oil level indicator receives its signal from the oil level sending unit. The 24 VDC power comes from the main breaker panel through the sending unit and activates the low level indicator.

WINDSHIELD WIPER. The operator control switch provides power to the wiper motor from the cab circuit breaker panel main 24 VDC power system.

CAB HEATER. The cab heater is electrically powered from the 24 VDC power system through the A3 panel located in the operators cab. A toggle switch controls the fan and the temperature is controlled by a thermostat located above the heater vent.

WINDOW DEFROSTER. The cab defroster is electrically powered by the 24 VDC power system through the A3 panel located in the operators cab. The defroster is controlled by a three position switch FAN, OFF and HEAT. The HEAT position operates the fan and heat. The temperature is controlled by the THERMOSTAT control knob. Rotating the knob to the right (clockwise) increases the temperature and rotating the knob to the left (counter clockwise) decreases the temperature

CAB CIRCUIT BREAKER PANEL. The operators cab circuit breaker panel provides circuit protection for all electrical circuits in the operators cab. The panel also provides testing jacks for testing the operators cab electrical circuits.

HYDRAULIC SYSTEM

Powered (Normal) Operation

The hydraulic system contained within each propulsion module provides the steering power and control for rotation of the pump-jet discharge nozzle. The four subsystems comprising this system include: 1) the reservoir system that stores, cools and filters the hydraulic fluid being pumped through the system; 2) the pump drive system, which provides the power to the steering motor; 3) the way-valve assembly, which protects the hydraulic system from over pressurization and controls the actuation of the hydraulic steering motor and; 4) the hydraulic steering motor drive system, which turns the discharge nozzle through 360° continuous rotation in both directions.

Emergency (Manual) Operation

In the event of loss of steering control at the cab due to an electrical failure, the steering system can be manually operated by one of two methods: 1) the use of a manual control lever on the way-valve unit and; 2) the fit-up of the emergency steering unit on the auxiliary planetary gearbox with manual release of the hydraulic brake.

Hydraulic Reservoir

In addition to storing the system hydraulic fluid, the hydraulic reservoir also cools 26 gallons of fluid with open air to all sides, including top and bottom. It also filters the oil through the suction line strainer, return line filter and filler neck screen. The reservoir is equipped with an external sight level gauge to determine actual fluid level and an in-tank float switch to monitor fluid level within and to notify the operator via an indicating light in the cab when it falls below the required level.

Hydraulic Pump

The axial piston hydraulic pump provides the power to drive the hydraulic motor. The pump is driven off the marine gear and is fitted with a flow control regulator. The drive shaft of the hydraulic pump drives a cylinder block causing the pistons within to move in an axial direction. The stroke of the pistons is limited by an internal swash plate which adjusts around the vertical axis of the input shaft, varying the displacement of oil flow infinitely.

Way-Valve Unit

The proportional way-valve is controlled by means of the electrically operated proportional pressure valves or manually by means of the lever on the valve unit. The way-valve guides the hydraulic oil via the dual braking valve to the hydraulic motor.

Dual Braking Valve

The dual braking valve (load retaining valve) avoids uncontrolled rotation of the hydraulic motor caused by negative loads and locks the lines to the hydraulic motor tightly when the way-valve is in the rest position.

Hydraulic Motor

The hydraulic motor is mounted on the input shaft of the pump-jet steering planetary gearbox. The axial piston motor is a constant speed unit with fixed oblique discs supporting nine pistons configured as a rotor.

Three-Way-Valve

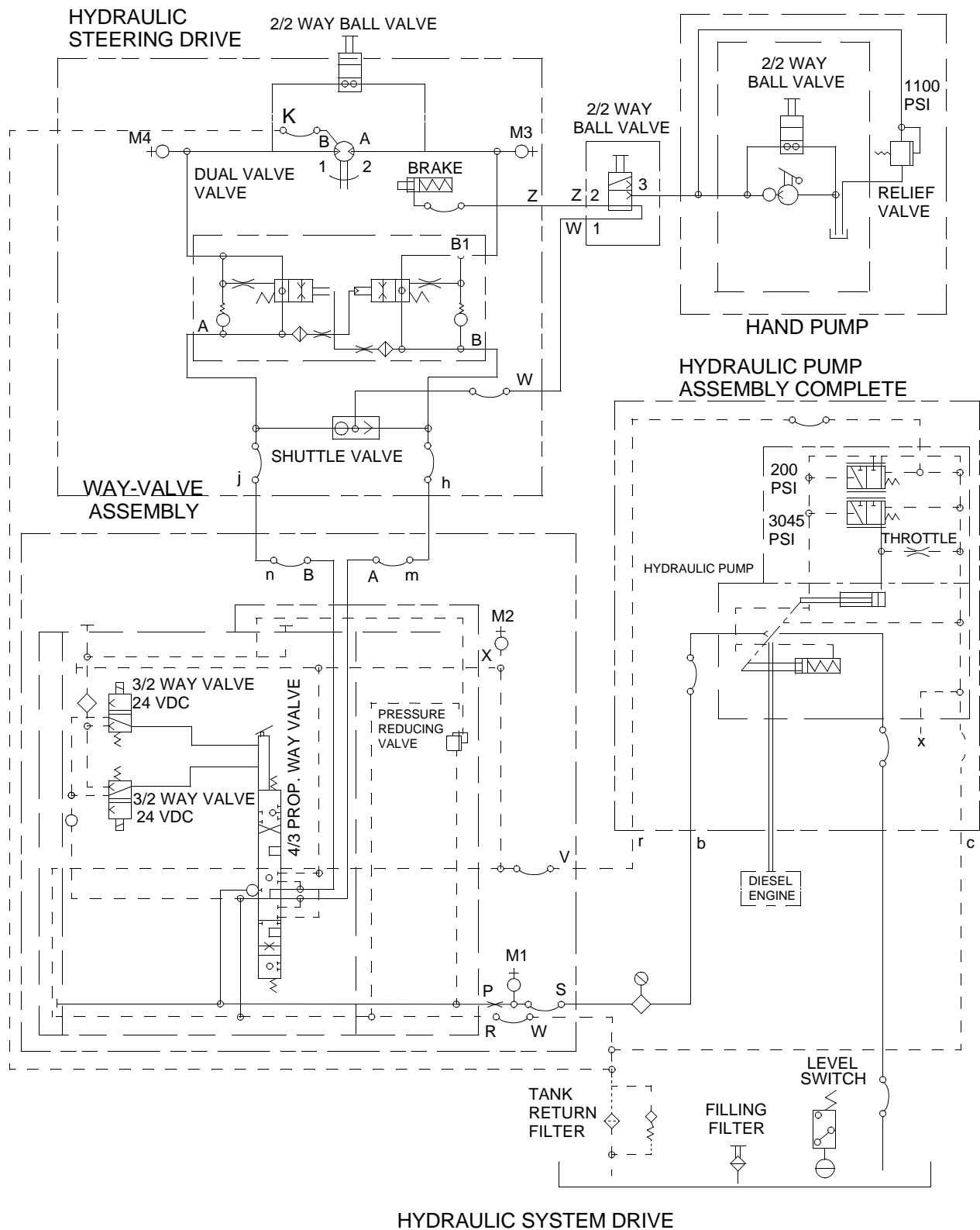
A manually operated, lever actuated, three-way-valve is positioned to select normal hydraulic operation or to isolate the normal hydraulic system, so the manual hydraulic hand pump can be used to release the hydraulic brake for emergency steering operation.

Two-Way-Valve

A two-way (needle) valve in the closed position during normal operation must be opened to allow for the manual releasing of the hydraulic brake via the hydraulic hand pump.

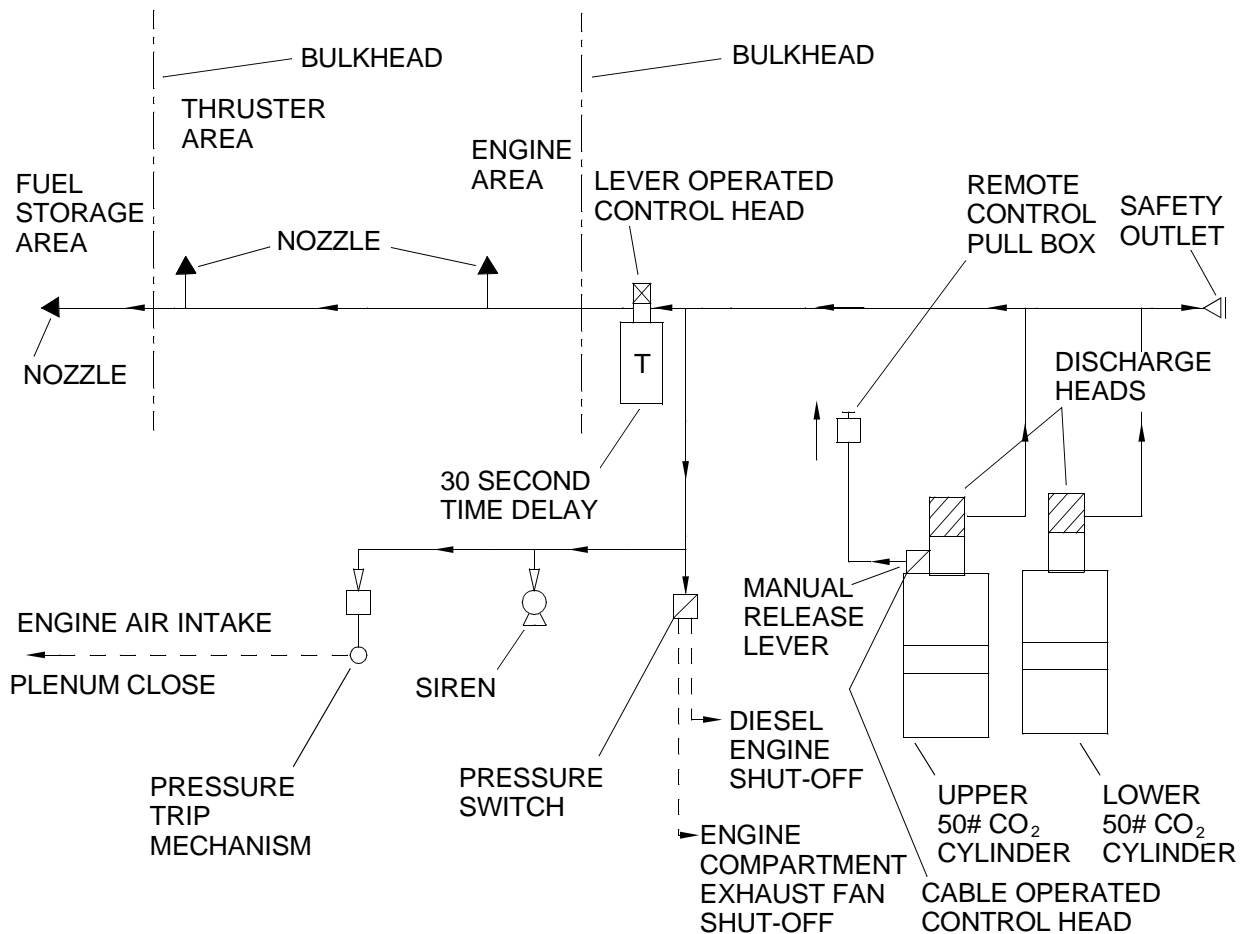
Manual Hydraulic Hand Pump

The hydraulic hand pump used to release the hydraulic brake for emergency steering operation is equipped with its own small hydraulic reservoir, pressure relief valve and oil level dipstick.



FIRE SUPPRESSION SYSTEM

The fire suppression system is designed to flood the powered module machinery and fuel storage compartments with carbon dioxide (CO2) if a fire occurs. System activation is accomplished manually using a remote control pull box recessed in the deck directly forward of the operators cab and air intake plenum. Manual activation is also provided below deck in the lazaret, where the agent is stored, but not dispersed. The upper 50 lb CO2 cylinder is equipped with a manual release lever, which initiates discharge the same way as the remote control pull box handle. The 30 second time delay device is also equipped with a manual release handle. However, actuation using this control will bypass the 30 second time delay. Upon activation, CO2 is released into the system. The discharged CO2 is directed down two circuit paths. One circuit directs the agent to a pressure operated switch, which immediately shuts off the diesel engine and machinery compartment exhaust fan. The flow of CO2 also activates a warning siren and operates a pressure trip mechanism to close off the machinery compartment air intake plenum opening. The second circuit directs CO2 to a 30 second time delay device to allow evacuation time for personnel prior to CO2 discharge into the protected compartments via the three nozzles. It also provides the delay time needed for the other circuit to shut-down the engine and close all air intake and exhaust systems.



FIRE SUPPRESSION SYSTEM SCHEMATIC

Deck Fittings

CF assemblies are provided with deck fittings to meet various operational needs. Available fittings include deck cleats and a combination Cloverleaf/D-ring. These fittings have a 30,000-pound load capacity. There are 10 tube turns per non-powered nodule and five per end rake. The CF modules are provided with recessed lift shackles welded into the deck structure. Shackles have a safe working load capacity of 35 tons. There are two shackles per center and propulsion module and one per end rake. When stowed, the shackles fold down flush with deck.

CHAPTER 2

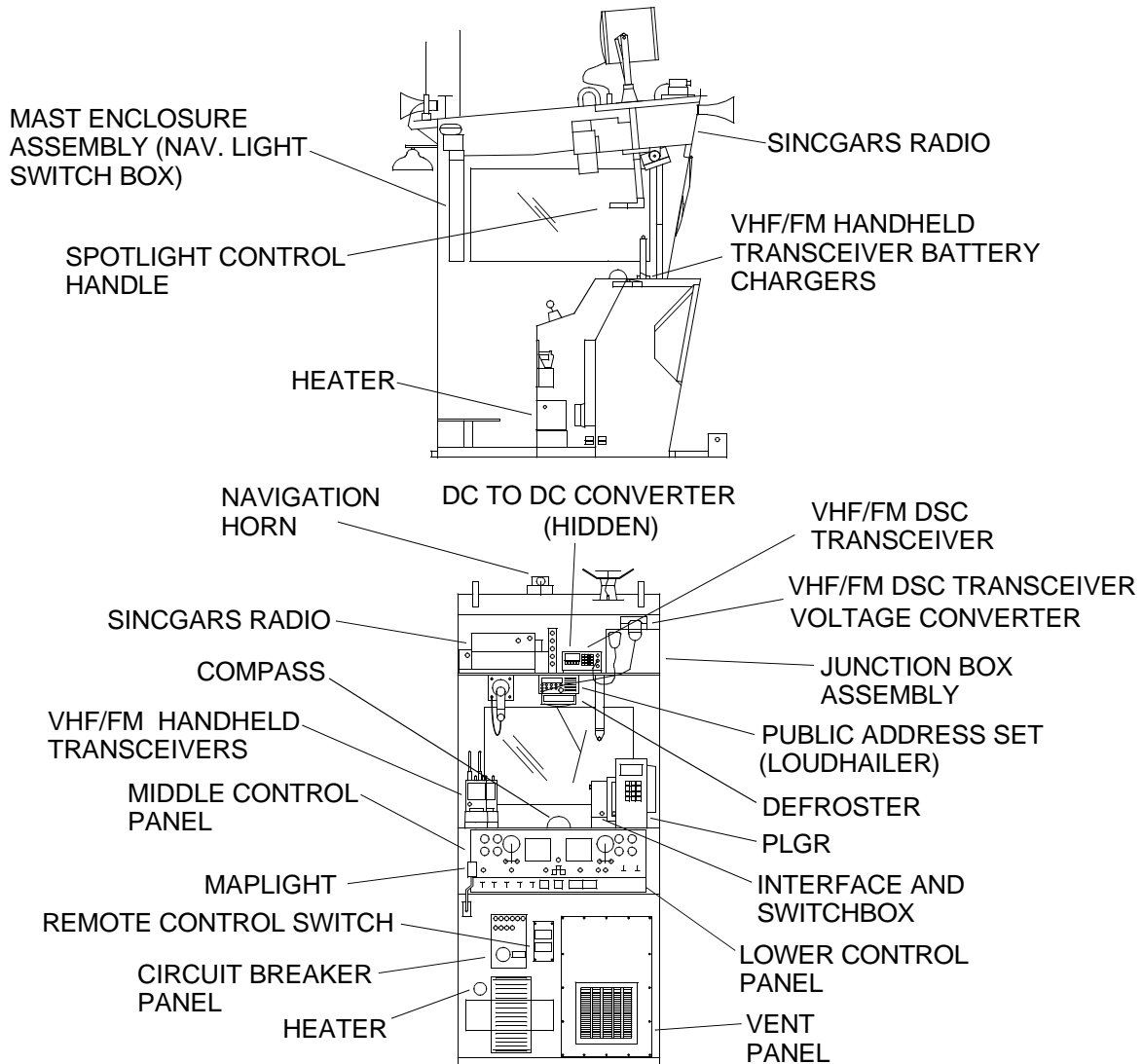
OPERATOR INSTRUCTIONS
FOR
MODULAR CAUSEWAY SYSTEM (MCS)
CAUSEWAY FERRY (CF)

**OPERATOR MAINTENANCE
CAUSEWAY FERRY
DESCRIPTION AND USE OF OPERATOR
CONTROLS AND INDICATORS**

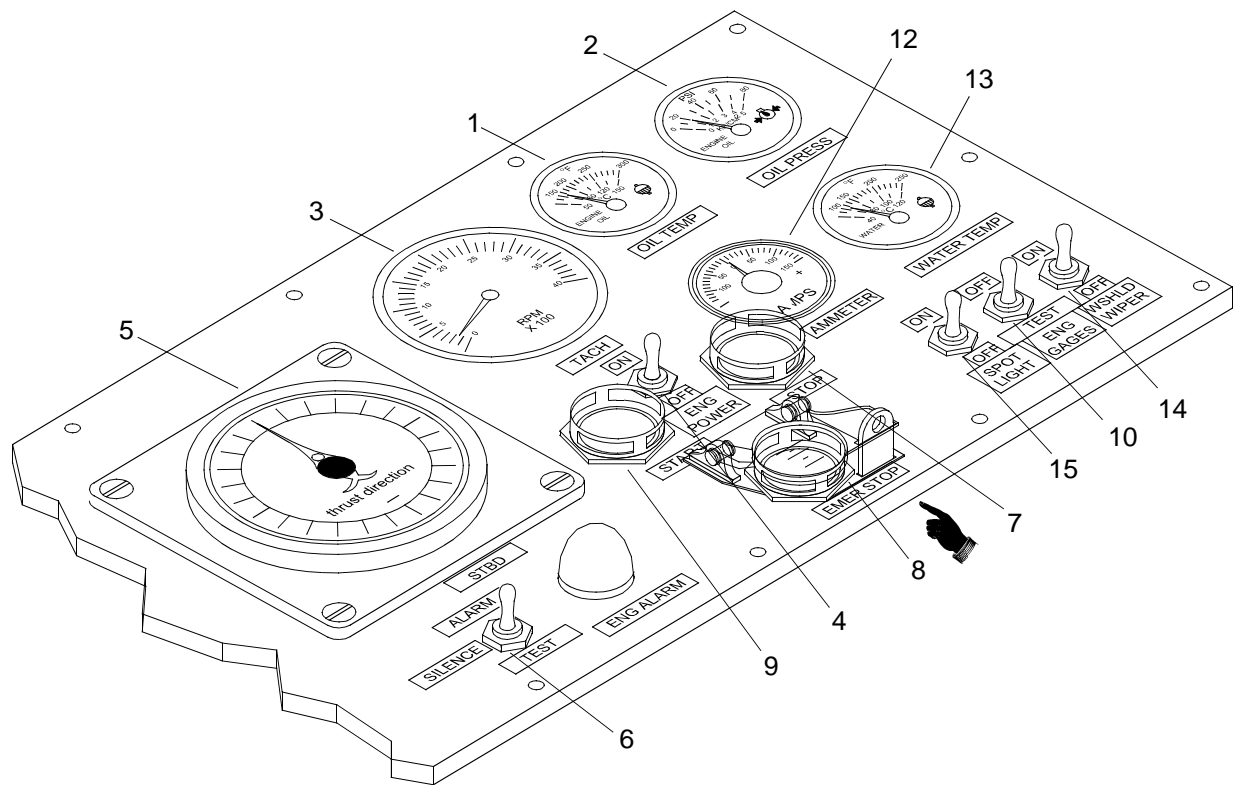
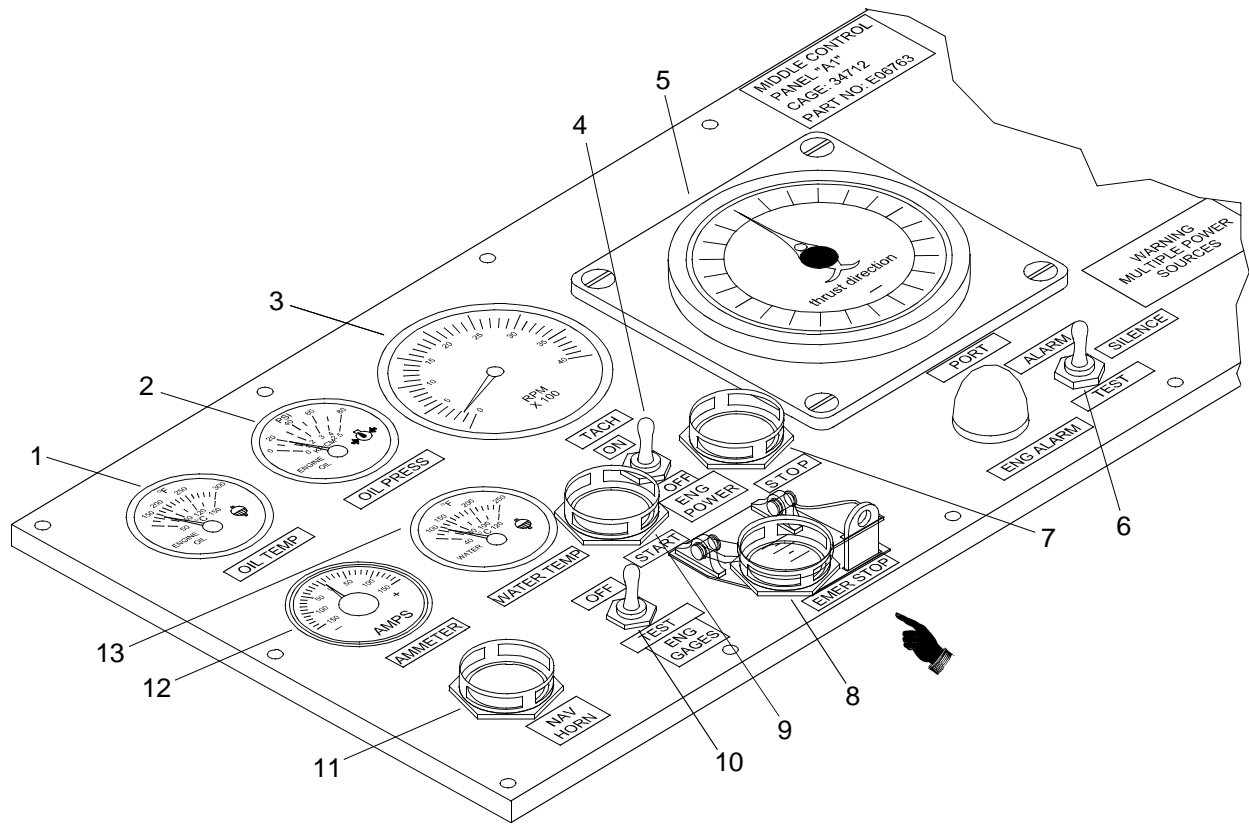
INTRODUCTION

This work package contains tables and illustrations depicting the location of each control and/or indicator for operation of the CF. The tables are broken down into three major areas: operators cab/above deck, below deck and emergency equipment. Each control and/or indicator is clearly labeled as it appears on the equipment. Numbers on illustrations are keyed to the tabular listing which contains the name (based on the equipment markings) and the functional description of each control and/or indicator.

OPERATORS CAB AND ABOVE DECK CONTROLS AND INDICATORS (OVERVIEW)



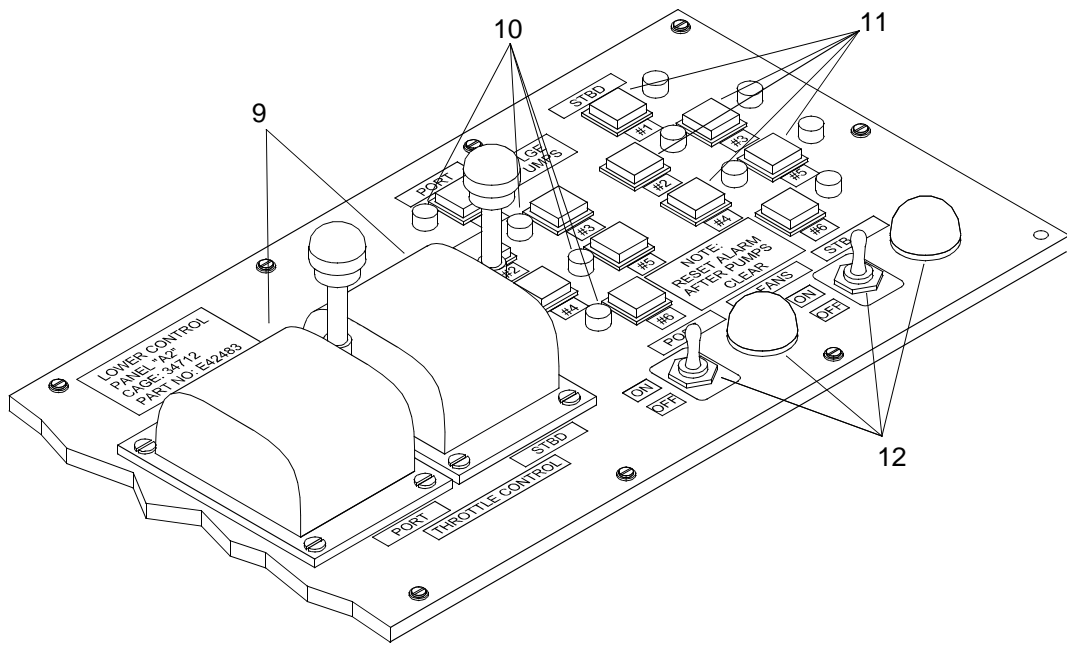
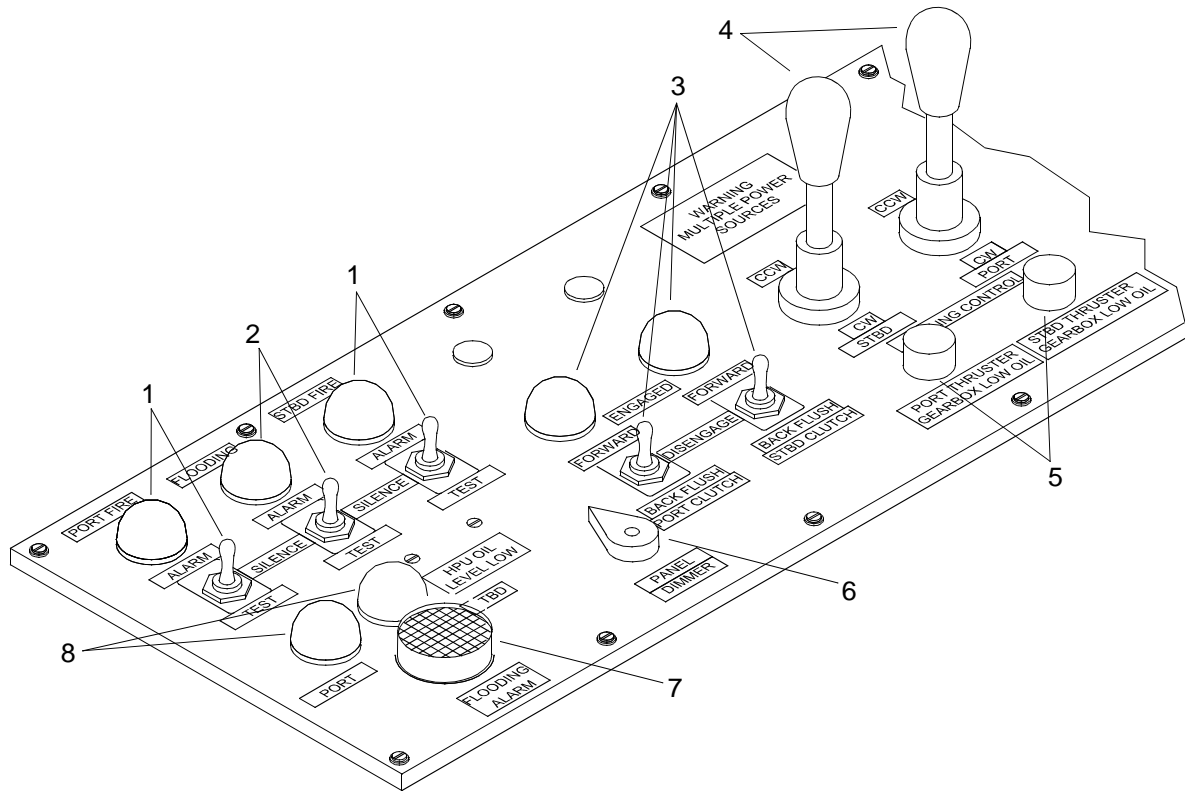
DESCRIPTION OF OPERATOR CONTROLS AND INDICATORS, MIDDLE CONTROL PANEL (A1)



■ **Table 1. Middle Control Panel (A1) Controls and Indicators.**

KEY	CONTROL/INDICATOR	FUNCTION
1	OIL TEMP Gauges (Port and Starboard)	Indicates engine oil temperature (normal operating 215 - 230°F).
2	OIL PRESS Gauges (Port and Starboard)	Indicates engine oil pressure (normal operating 50 - 70 PSI).
3	TACH Gauges (Port and Starboard)	Indicates engine speed (0 - 4,000 RPM).
4	ENG POWER Toggle Switches (Port and Starboard)	Turns power ON/OFF to electrical system.
5	THRUST DIRECTION Dial Indicators (Port and Starboard)	Indicates direction of the thrust by the pump-jet thrusters (clockwise and counterclockwise) that control CF movement.
6	Engine ALARM Toggle Switches with Red Indicator Lights (Port and Starboard)	Engine Alarm System. Audible alarm bell sounds and red light illumination indicates low oil pressure or high water temperature. If alarm is sounded, operator must visually observe port and starboard engine alarm indicator lights to determine which engine is indicating a problem. ALARM = bell sounds and red light comes on. SILENCE = bell alarm silenced, red light remains on. TEST (momentary) = bell sounds, red light comes on.
7	STOP Pushbuttons (Port and Starboard)	When depressed, shuts down electrical circuit to stop the engine.
8	EMER STOP Pushbuttons (Port and Starboard)	When plastic cover is raised and button is depressed, shuts down engine by cutting off air supply.
9	START Pushbuttons (Port and Starboard)	When depressed, completes electrical circuit to start engine.
10	ENG GAGES Toggle Switches (Port and Starboard)	Allows engine gauges, indicating oil pressure, water temperature and amperage to be read without engine(s) running (TEST). Otherwise, toggle left in OFF position.
11	NAV HORN Pushbutton	When depressed, navigation horn sounds.
12	AMMETER Gauges (Port and Starboard)	Indicates battery charge and discharge.
13	WATER TEMP Gauges (Port and Starboard)	Indicates engine water temperature (normal operating 170 - 185°F).
14	WSHLD WIPER Toggle Switch	Turns windshield wiper ON/OFF.
15	SPOTLIGHT Toggle Switch	Turns spotlight ON/OFF.

DESCRIPTION OF OPERATOR CONTROLS AND INDICATORS, LOWER CONTROL PANEL (A2)



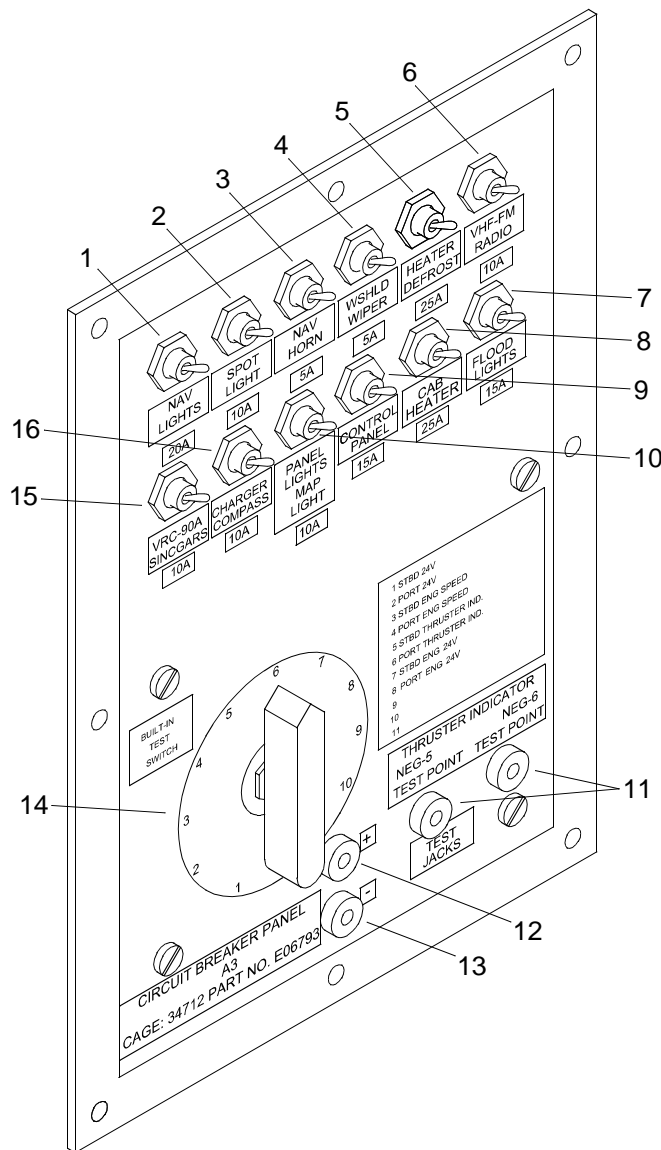
■ **Table 2. Lower Control Panel (A2) Controls and Indicators.**

KEY	CONTROL/INDICATOR	FUNCTION
1	PORT FIRE and STBD FIRE Toggle Switches with Red Indicator Lights	Audible alarm (horn) indicates below deck temperature above 225°F indicates a possible fire in port and/or starboard propulsion module. ALARM = horn sounds and red light on. SILENCE = horn silenced, red light remains on. TEST (momentary) = horn sounds, red light goes on. Reset to ALARM when normal conditions exist.
2	FLOODING Toggle Switch with Red Indicator Light	Audible alarm (pulse beeper) indicates possible flooding in port and/or starboard propulsion module. ALARM = pulse beeper sounds and red light on. SILENCE = pulse beeper is silenced, red light on. TEST (momentary) = pulse beeper sounds, red light on. Reset to ALARM when normal conditions exist.
3	PORT and STBD CLUTCH Toggle Switches with Green (ENGAGED) Indicator Lights	Control clutch engagements. To engage clutch FORWARD, position toggle switch up. Green light comes on. To DISENGAGE, return toggle to center position. Green light goes off. To engage clutch to BACKFLUSH, lift up on switch handle and position toggle switch down. Green light comes on.
4	PORT and STBD STEERING CONTROL Joystick Levers	Control directional rotation of the pump-jet steering nozzles. Pull level back to produce clockwise CW rotation. Push lever forward to produce counterclockwise CCW rotation. Thrust direction indicators located on the middle control panel will rotate accordingly.
5	PORT and STBD THRUSTER GEARBOX LOW OIL Red Indicator Lights	Red light illuminates when pump-jet gearbox oil level is below required operating level.
6	PANEL DIMMER Rotating Switch	Controls brightness of green and amber indicator lights, thrust direction dial indicator lights, compass and gauge control lights on both middle and lower panels for night operations.
7	FLOODING ALARM Pulse Beeper w/Speaker	Audible pulse beeper that sounds when flooding of the powered module occurs and the FLOODING toggle switch is set to ALARM (Item 3).
8	HPU OIL LEVEL LOW Red Indicator Lights (Port and Starboard)	Red light illuminates when Hydraulic Power Unit (HPU) oil level is below required operating level.
9	PORT and STBD THROTTLE CONTROL Levers	Levers control engine RPMs which are indicated on tachometer gauges. Push forward for higher RPMs or pull back to reduce RPMs.
10	Bilge Pump Red Indicator Lights (Port and Starboard)	Six red indicator lights for each module (total of 12 on the control panel) illuminates when a float switch is tripped by water.

Table 2. Lower Control Panel (A2) Controls and Indicators. (Continued)

KEY	CONTROL/INDICATOR	FUNCTION
11	PORT and STBD BILGE PUMPS Buttons with Green Indicator Lights	Six green buttons for each module (total of 12 on the control panel) control the operation of bilge pumps and illuminate when pumps are functioning.
12	PORT and STBD VENT FANS Toggle Switches with Amber Indicator Lights	ON/OFF control of exhaust plenum vent fans. Amber light is illuminated when switch is on and vent fans are functioning.

**DESCRIPTION OF OPERATOR CONTROLS AND INDICATORS, OPERATORS CAB
CIRCUIT BREAKER PANEL (A3).**



■ **Table 3. Operators Cab Circuit Breaker Panel (A3) Controls and Indicators.**

KEY	CONTROL/INDICATOR	FUNCTION
1	NAV LIGHTS Circuit Breaker, 20A	Up (On)/Down (Off) = Controls electrical power to the mast enclosure (navigation light switch box).
2	SPOTLIGHT Circuit Breaker, 10A	Up (On)/Down (Off) = Controls electrical power to the spotlight toggle switch on the middle control panel.
3	NAV HORN Circuit Breaker, 5A	Up (On)/Down (Off) = Controls electrical power to the navigational horn pushbutton on the middle control panel.
4	WSHLD WIPER Circuit Breaker, 5A	Up (On)/Down (Off) = Controls electrical power to windshield wiper toggle switch on the middle control panel.
5	HEATER DEFROST Circuit Breaker, 25A	Up (On)/Down (Off) = Controls electrical power to the cab defroster.
6	VHF/FM Radio Circuit Breaker, 10A	Up (On)/Down (Off) = Controls electrical power to VHF/FM DSC transceiver in operators cab.
7	FLOOD LIGHTS, Circuit Breaker, 15A	Up (On)/Down (Off) = Controls electrical power to flood lights.
8	CAB HEATER Circuit Breaker, 25A	Up (On)/Down (Off) = Controls electrical power to operators cab heater.
9	CONTROL PANEL Circuit Breaker, 15A	Up (On)/Down (Off) = Controls electrical power to alarms, emergency stops and bilge pumps in operators cab.
10	PANEL LIGHTS/MAP LIGHT Circuit Breaker, 10A	Up (On)/Down (Off) = Controls electrical power to panel lights dimmer control and map light located on lower control panel.
11	THRUSTER INDICATOR NEG-5 and NEG-6 Jack Plug TEST JACKS	Negative Plug ins = Two connections for diagnostic tester.
12	+ Jack Plug (Positive)	Positive Plug in = Connection for diagnostic tester.
13	- Jack Plug (Negative)	Negative Plug in = Connection for diagnostic tester.
14	BUILT IN TEST SWITCH	11 rotary contact function switch to troubleshoot controls.
15	VRC-90A SINCGARS Circuit Breaker, 10A	Up (On)/Down (Off) = Controls electrical power to SINCGARS radio transmitter in operators cab.
16	CHARGER/COMPASS, 10A	Up (On)/Down (Off) = Controls electrical power to RADIO CHARGER and Compass.

DESCRIPTION OF OPERATOR CONTROLS AND INDICATORS, VHF/FM DSC TRANSCEIVER

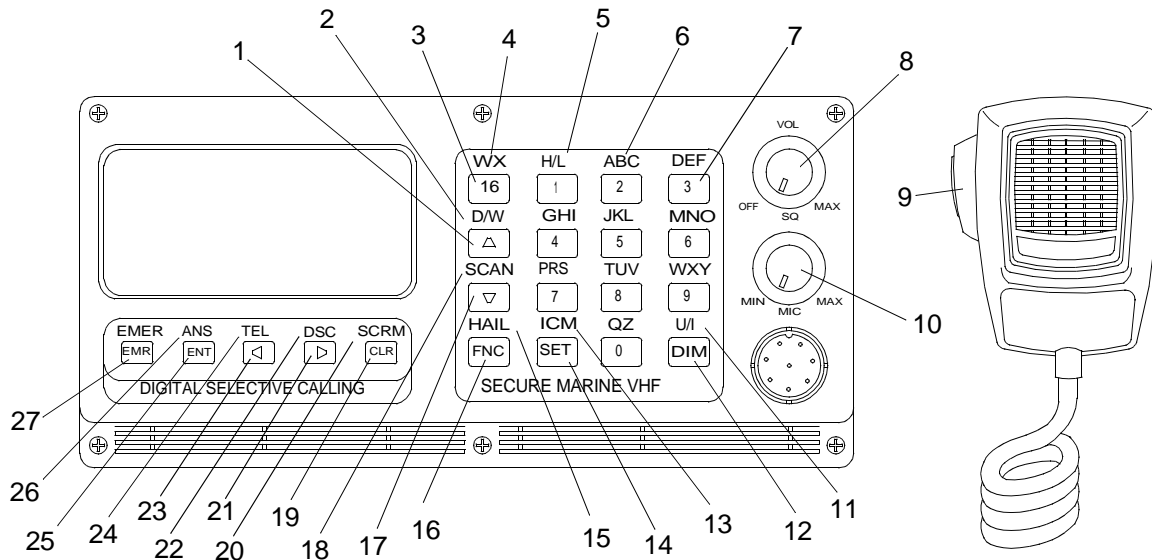


Table 4. VHF/FM DSC Transceiver Controls and Indicators.

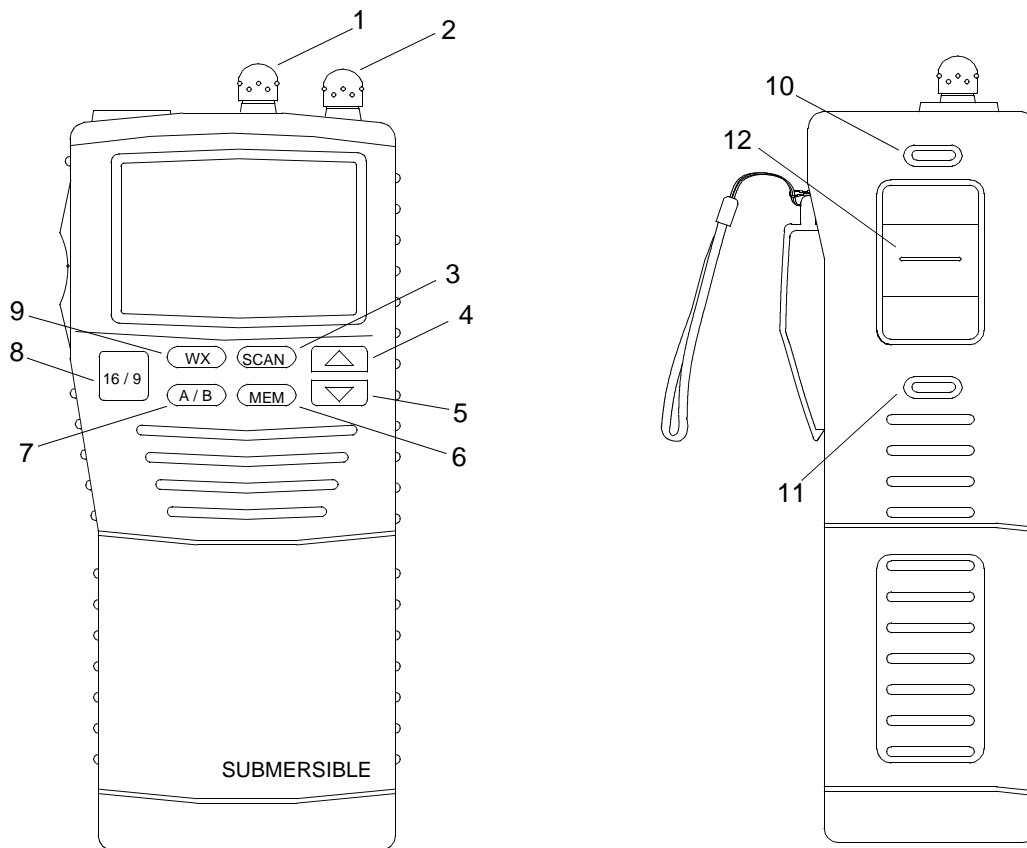
KEY	CONTROL/INDICATOR	FUNCTION
1	Up Arrow Key	Used to select the next higher channel number or move selection bar upward in menus.
2	D/W Key	Dual Watch. Allows any two channels to be selected and monitored simultaneously.
3	16 Key	Sets the transceiver to transmit and receive on channel 16 and overrides any other function when pressed.
4	WX Key	Allows 10 weather channels to be selected individually or scanned.
5	H/L Key	High/Low. Selects HIGH (25 watt) or LOW (1 watt) transmit power. Also selects LOCAL or DISTANCE receive mode.
6	Letter Keys	Used for entry of names into directories.
7	Number Keys	Used for channel selection and entry of numeric values.
8	Off/Volume Knob	Turns power on and off. Adjusts speaker volume level.
9	Microphone Push To Talk Button	Press the button to transmit. Release button to receive. A transmit timer limits continuous transmission to 5 minutes.
10	Squelch Knob	Sets the threshold level (squelch) of received signals that will produce audio output from the speaker.
11	U/I Key	USA or International. Selects USA or International frequency sets.
12	DIM Key	Selects any of four display backlighting levels; Low, Medium, High or Off.

■ **Table 4. VHF/FM DSC Transceiver Controls and Indicators. (Continued)**

KEY	CONTROL/INDICATOR	FUNCTION
13	ICM Key	Intercom. Activates the INTERCOM mode. Remote station speakers required.
14	SET Key	Displays USER SETUPS menu. Choose from Clock, Viewing Angle, User Options, NMEA Position and Security Code.
15	HAIL Key	Activates the HAIL mode. Remote speaker required.
16	FNC Key	Function key. Selects the second function for a key. The second function is shown above the key. Does not select the letters above keys 2 thru 0.
17	Down Arrow Key	Used to select the next lower channel number or move selection bar downward in menus.
18	SCAN Key	Displays SCAN SELECTION menu. Choose MEMORY SCAN, ALL CHANNELS or SCAN REVIEW.
19	CLR Key	Clear key. Clears erroneous entries. Clears displayed channel from MEMORY SCAN memory. Stops call ringing.
20	SCRM Key	Scrambler. Displays the SCRAMBLER selections menu. Choose INDIVIDUAL, GROUP SCRAMBLE or SEARCH for directory entry.
21	Right Arrow Key	Used to change pages in multiple page menus and advance the entry position when entering or editing data.
22	DSC Key	Displays the DSC CALLING and several other menus regarding DSC operations. Use arrow keys to make selection.
23	Left Arrow Key	Used to change pages in multiple page menus and backspace the entry position when entering or editing data.
24	TEL Key	Displays the TELEPHONE and COAST STATION menus. Choose any existing entry, new entry or search for individual telephone numbers and coast station DSC ID numbers.
25	ENT Key	Enter. Used to complete selections and terminate multiple key entries. Enter displayed channel into MEMORY SCAN memory.
26	ANS Key	Answer. Displays the CALL WAITING menu. Select any entry to respond.
27	EMR Key	Emergency key. Displays the EMERGENCY menu. When SEND DISTRESS is selected and button is pushed and held in for five seconds, transmits emergency message on channel 70.

**DESCRIPTION OF OPERATOR CONTROLS AND INDICATORS, AN/VRC-88D
SINGARS RADIO TRANSMITTER**

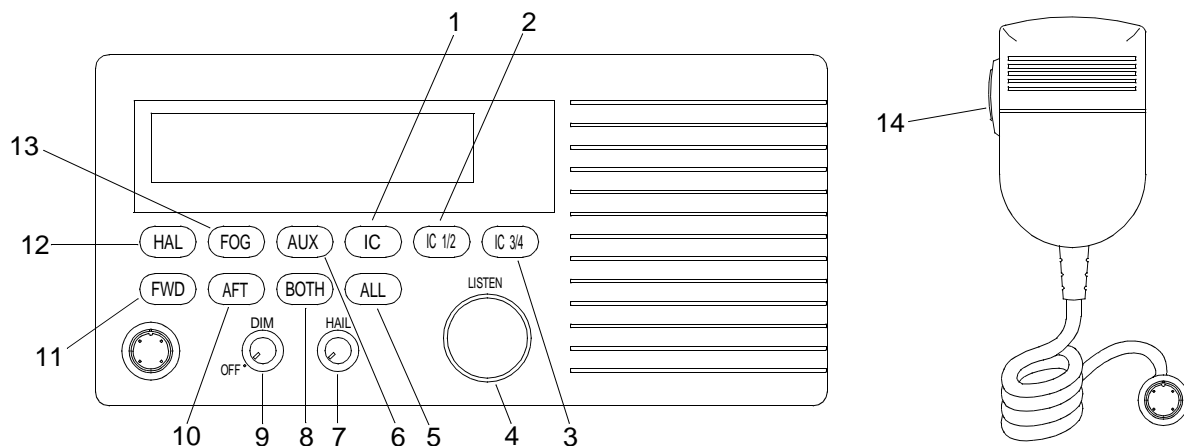
Refer to AN/VRC-88D SINGARS Radio Operators Manual, TM 11-5820-890-10-8, for controls and indicators.

**DESCRIPTION OF OPERATOR CONTROLS AND INDICATORS, VHF/FM
HANDHELD TRANSCEIVER**

Table 5. VHF/FM Handheld Transceiver Controls and Indicators.

KEY	CONTROL/INDICATOR	FUNCTION
1	SQUELCH CONTROL Knob	Sets the threshold level of signals that will produce audio output from the speaker.
2	POWER/VOLUME Knob	Turns power on and off. Adjusts speaker level.
3	SCAN Key	Starts scanning programmed channels. Press key for at least one second to turn on and off priority scan during scan.
4	Up Arrow Key	Selects the desired channel. Each press increases the channel number. When held down, the channels increase continuously.
5	Down Arrow Key	Selects the desired channel. Each press decreases the channel number. When held down, the channels decrease continuously.
6	MEM Key	Memorizes the selected channel. When pressed again, deletes the selected channel.
7	A/B Key	Immediately recalls two user assigned channels from any channel location.

■ **Table 5. VHF/FM Handheld Transceiver Controls and Indicators. (Continued)**

KEY	CONTROL/INDICATOR	FUNCTION
8	16/9 Key	Immediately recalls channel 16 from any channel location. Holding this key down recalls channel 9. When the WX key is pressed while holding this key, the mode toggles between USA, International and Canada.
9	WX Key	Immediately recalls a weather channel from any channel location. Recalls the previous channel when the WX key is pressed again.
10	LAMP/KEY LOCK Key	Turns the display lamp on and off. Hold down key to lock the displayed channel. Key symbol appears in display. Hold down until key symbol in display disappears to unlock.
11	H/L Key	Toggles between high and low power. To change from low power to high power, hold down key on Canada channel 13, USA channel 13 or 67.
12	Microphone PUSH TO TALK (PTT) Switch	Press the PUSH TO TALK switch to transmit. Release button to receive. A transmit timer limits continuous transmissions to 5 minutes.

DESCRIPTION OF OPERATOR CONTROLS AND INDICATORS, PUBLIC ADDRESS SET (LOUDHAILER)

Table 6. Public Address Set (Loudhailer) Controls and Indicators.

KEY	CONTROL/INDICATOR	FUNCTION
1	IC Key	Intercom. Pressing this key puts the loudhailer in the INTERCOM mode.
2	IC1/2 Key	Selects between intercom station one and two.
3	IC 3/4 Key	Selects between intercom station three and four.
4	LISTEN Control Knob	Rotating the knob clockwise increases the volume to the internal speaker, rotating the knob counterclockwise decreases the volume to the internal speaker.
5	ALL Key	Selects the input/output circuitry to all speaker stations for use simultaneously during foghorn, hailer, or public address operations. When selecting intercom operations, select ALL intercom stations only.
6	AUX Key	When pressed, allows radio transmissions received on VHF/FM DSC transceiver to be monitored using the loudhailer external horn.
7	HAIL Output Knob	Rotating the knob clockwise increases the volume to the hailer horns, rotating the knob counterclockwise decreases the volume to the hailer horn.
8	BOTH Key	Selects both forward and aft loudhailer horns.
9	ON/OFF and DIMMER Knob	Rotating the knob clockwise turns the loudhailer on, rotating the knob counterclockwise turns the loudhailer off. Rotating the knob adjusts the display backlighting level.
10	AFT Key	Selects the aft loudhailer horn.
11	FWD Key	Forward. Selects the forward loudhailer horn.
12	HAIL Key	Pressing this key puts the loudhailer into the HAIL mode. HAILER is displayed on the LCD.
13	FOG Key	Pressing the FOG key sequentially selects one of nine different horn or automatic fog signals.
14	Microphone PUSH TO TALK Switch	When pressed allows operator to transmit. Allows listening when not pressed.

**DESCRIPTION OF OPERATOR CONTROLS AND INDICATORS, AN/PSN-11(V)1
PRECISION GLOBAL POSITIONING RECEIVER (PLGR)**

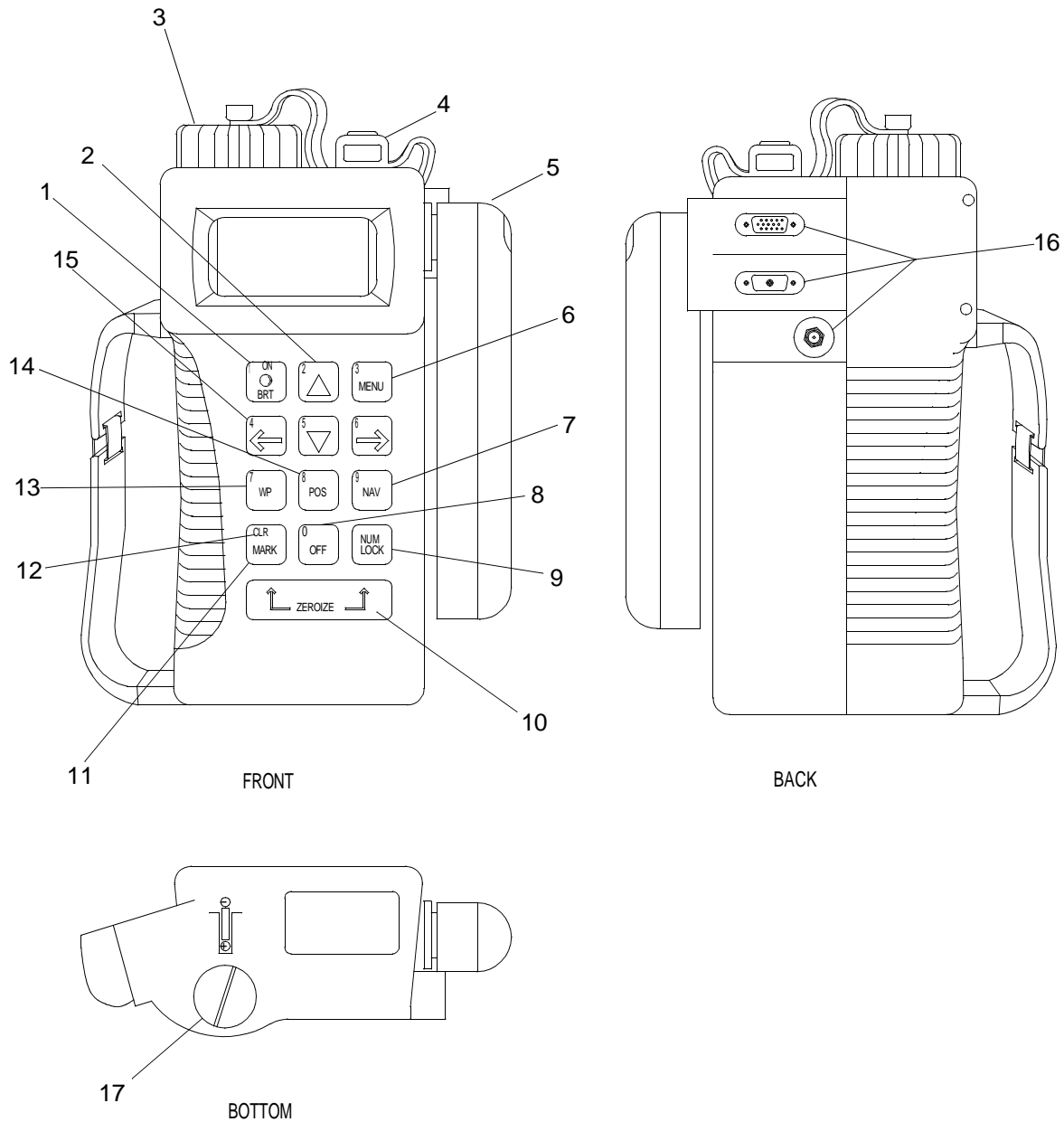


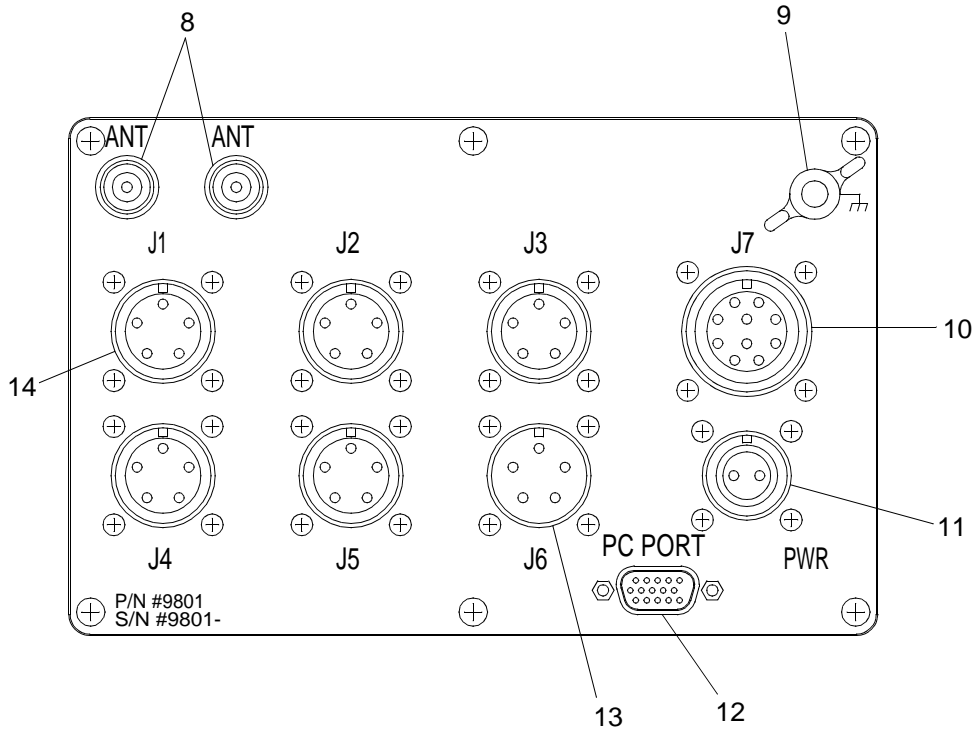
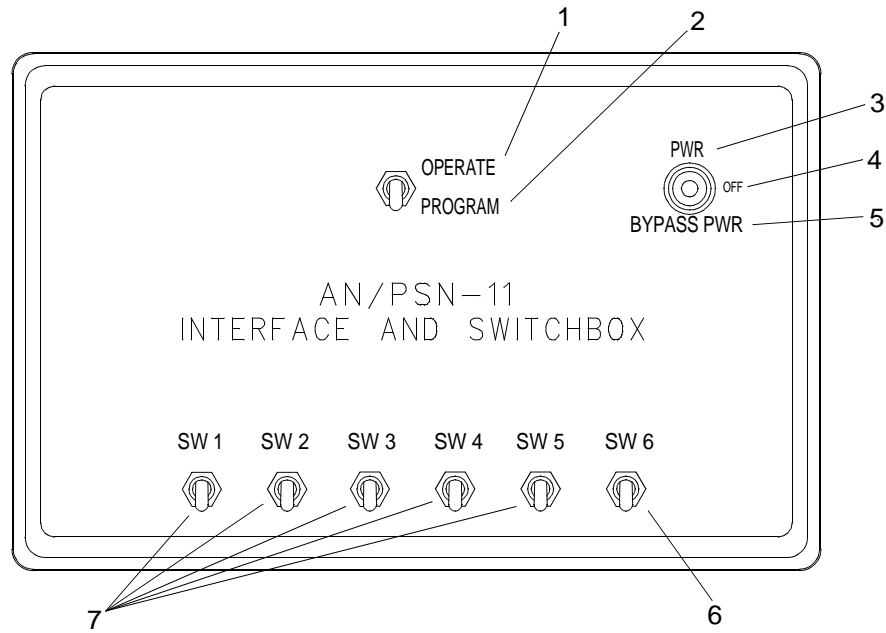
Table 7. AN/PSN-11(V)1 PLGR Controls and Indicators.

KEY	CONTROL/INDICATOR	FUNCTION
1	ON/BRT Key	Turns the PLGR on. Also adjusts the brightness of the display backlighting.
2	Up and Down Arrow Keys	Used to change display pages, change alphanumeric field values and activate functions.
3	Battery Compartment	Powers the PLGR when external power is not used. Battery must be removed before external power is applied.

■ **Table 7. AN/PSN-11(V)1 PLGR Controls and Indicators. (Continued)**

KEY	CONTROL/INDICATOR	FUNCTION
4	KYK-13 Encryption Port	When loaded, allows user to receive or read encrypted data.
5	Integral Antenna	Receives GPS signal when external antenna is not used.
6	MENU Key	Displays the system menu. Changes to new menu page.
7	NAV Key	Brings up the NAV menu displays. Key is inoperable until waypoints are loaded.
8	OFF Key	Turns the PLGR off.
9	NUM LOCK Key	Toggles the keyboard between control mode and numeric mode.
10	ZEROIZE Key	Destroys all data that has been entered into, collected or stored by the PLGR.
11	MARK Key	Activates the MARK and Man Overboard (MOB) waypoint selection page.
12	CLR KEY	Used in numeric mode. Moves the cursor to the left.
13	WP Key	Displays the WAYPOINT menu.
14	POS Key	Brings up the POSITION menu. Changes position display pages.
15	Left and Right Arrow Keys	Moves the cursor from field to field in the display.
16	J2, J3 and J4 Ports	Allows PLGR to be used with external power and provides external output of GPS data. Provides a receptacle for connecting PLGR to a data terminal.
17	Memory Battery Compartment	Contains memory battery which retains PLGR memory when the PLGR is turned off.

**DESCRIPTION OF OPERATOR CONTROLS AND INDICATORS, AN/PSN-11 PLGR
INTERFACE AND SWITCHBOX**



■ **Table 8. AN/PSN-11 PLGR Interface and Switchbox Controls and Indicators.**

KEY	CONTROL/INDICATOR	FUNCTION
1	Operate/Program Switch in OPERATE Position	Normal switch position for the interface and switchbox when installed in the navigation location.
2	Operate/Program Switch in PROGRAM Position	This switch position is not used when the interface and switchbox is installed in the navigation location.
3	Power Switch in PWR Position	Allows the interface and switchbox to receive power from ship's power source and supplies regulated power to the PLGR.
4	Power Switch in OFF Position	Allows the interface and switchbox to receive ship's power, but does not allow power output to PLGR.
5	Power Switch in BYPASS PWR Position	Allows interface and switchbox to receive ship's power and supplies unregulated power to the PLGR.
6	SW6	Allows interface of GPS differential signal data. Switch up for on, switch down for off.
7	SW1 - SW5	SW3 switches GPS signal on and off for VHF/FM transceiver. SW1, SW2, SW4 and SW5 not used.
8	ANT Connectors	Antenna connections for PLGR signal input and output. Connections are interchangeable.
9	Grounding Point	Grounding point for grounding the interface and switchbox to the vessel.
10	J7 Connector	Provides ship's power to PLGR.
11	PWR Connector	Receives power from ship power source to operate PLGR.
12	PC PORT Connector	Provides data terminal interface with PLGR for programming PLGR from data terminal.
13	J6 Connector	Allows input of GPS differential data.
14	J1 - J5 Connectors	J3 provides GPS signal to VHF/FM transceiver. J1, J2, J4 and J5 not used.

DESCRIPTION OF OPERATOR CONTROLS AND INDICATORS, DC TO DC CONVERTER

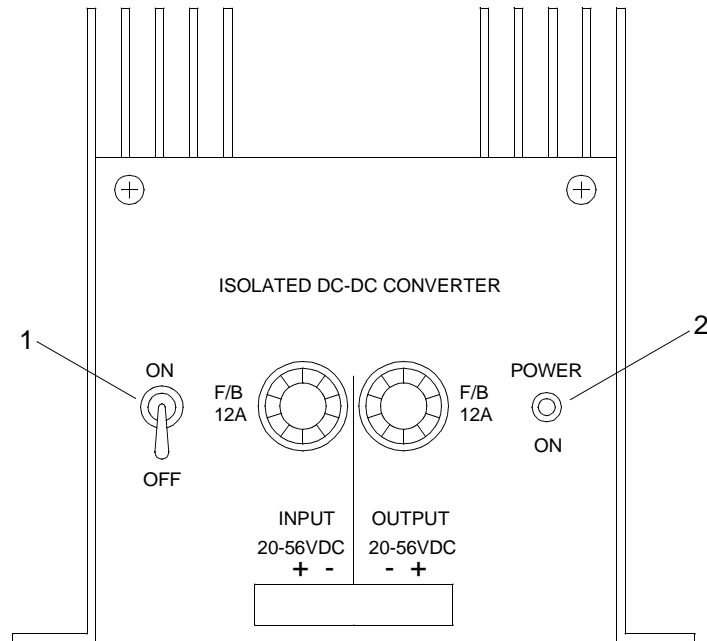


Table 9. DC to DC Converter Controls and Indicators.

KEY	CONTROL/INDICATOR	FUNCTION
1	ON/OFF Switch	Turns the converter on (up) or off (down).
2	POWER ON Red Indicator Light	Red light indicates that the converter is on.

DESCRIPTION OF OPERATOR CONTROLS AND INDICATORS, VHF/FM HANDHELD TRANSCEIVER BATTERY CHARGER

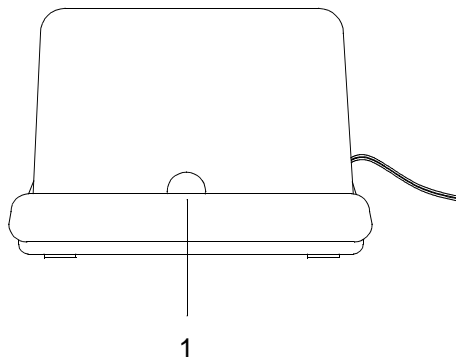
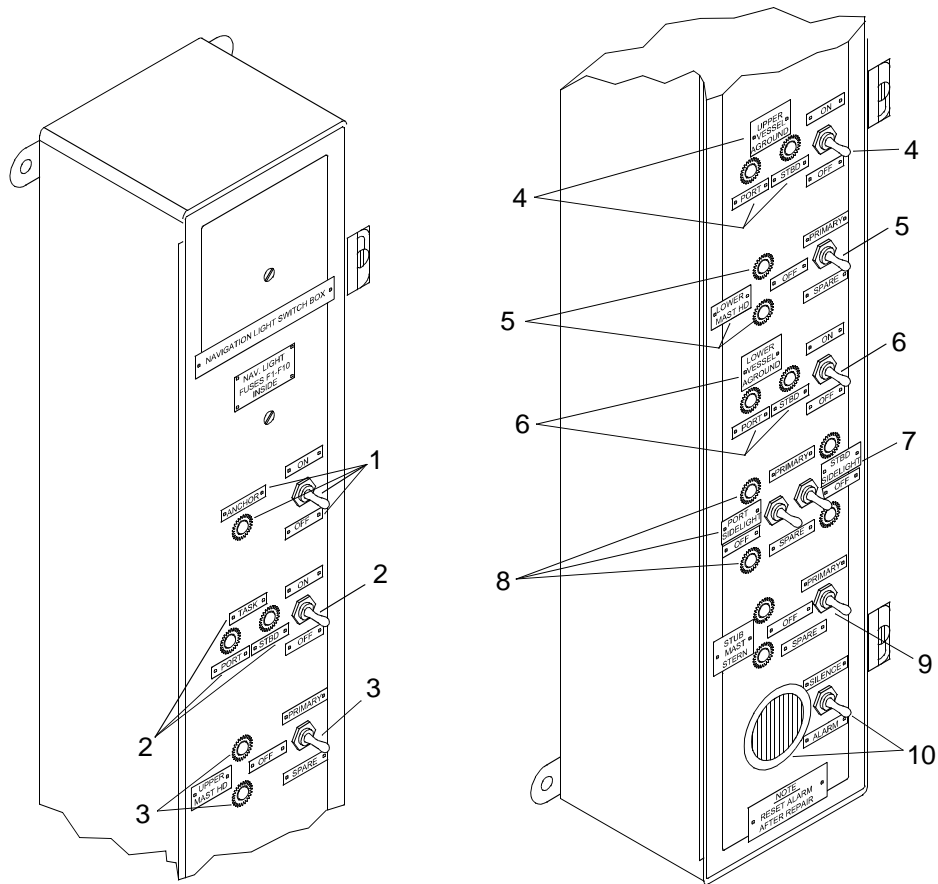


Table 10. VHF/FM Handheld Transceiver Battery Charger Controls and Indicators.

KEY	CONTROL/INDICATOR	FUNCTION
1	Power On/Recharging Red Indicator Light	Red light indicates the handheld radio is charging.

DESCRIPTION OF OPERATOR CONTROLS AND INDICATORS, MAST ENCLOSURE ASSEMBLY A7

Table 11. Mast Enclosure Assembly A7 Controls and Indicators.

KEY	CONTROL/INDICATOR	FUNCTION
1	ANCHOR Toggle Switch with Red Indicator Light	ON = illuminates anchor navigation light. OFF = light is extinguished.
2	TASK Toggle Switch with Red Indicator Light	ON = illuminates port and starboard task lights, OFF = lights are extinguished.
3	UPPER MAST HD Toggle Switch with Red Indicator Lights	PRIMARY = illuminates primary upper mast head light. OFF = light is extinguished. SPARE = illuminates spare upper mast head light.
4	UPPER VESSEL AGROUND Toggle Switch with Red Indicator Lights	ON = illuminates upper port and starboard vessel aground lights. OFF = lights are extinguished.
5	LOWER MAST HD Toggle Switch with Red Indicator Lights	PRIMARY = illuminates primary lower mast head light. OFF = light is extinguished. SPARE = illuminates spare lower mast head light.
6	LOWER VESSEL AGROUND Toggle Switch with Red Indicator Lights	ON = illuminates port and starboard lower vessel aground lights. OFF = lights are extinguished.

Table 11. Mast Enclosure Assembly A7 Controls and Indicators. (Continued)

KEY	CONTROL/INDICATOR	FUNCTION
7	STBD SIDELIGHT Toggle Switch with Red Indicator Lights	PRIMARY = illuminates primary starboard sidelight. OFF = light is extinguished. SPARE = illuminates spare starboard sidelight.
8	PORT SIDELIGHT Toggle Switch with Red Indicator Lights	PRIMARY = illuminates primary port sidelight. OFF = light is extinguished. SPARE = illuminates spare port sidelight.
9	Stub Mast Stern Toggle Switch with Indicators	NOT USED
10	ALARM/SILENCE Toggle Switch with Speaker	ALARM = pulse beeper alarm activates if a primary mast light becomes inoperative. SILENCE = pulse beeper audible alarm inactivated.

DESCRIPTION OF OPERATOR CONTROLS AND INDICATORS, STERN/BOW MAST LIGHTS

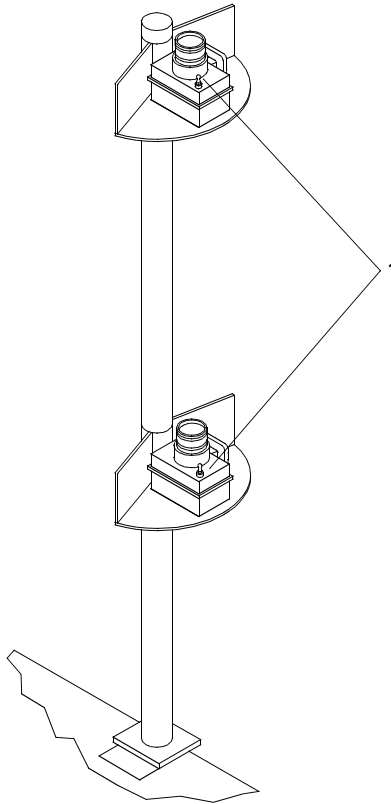


Table 12. Stern/Bow Mast Light Controls and Indicators.

KEY	CONTROL/INDICATOR	FUNCTION
1	ON/OFF Switch	Two position switch that turns stern/bow mast lights on or off.

DESCRIPTION OF OPERATOR CONTROLS AND INDICATORS, ACCESSORIES

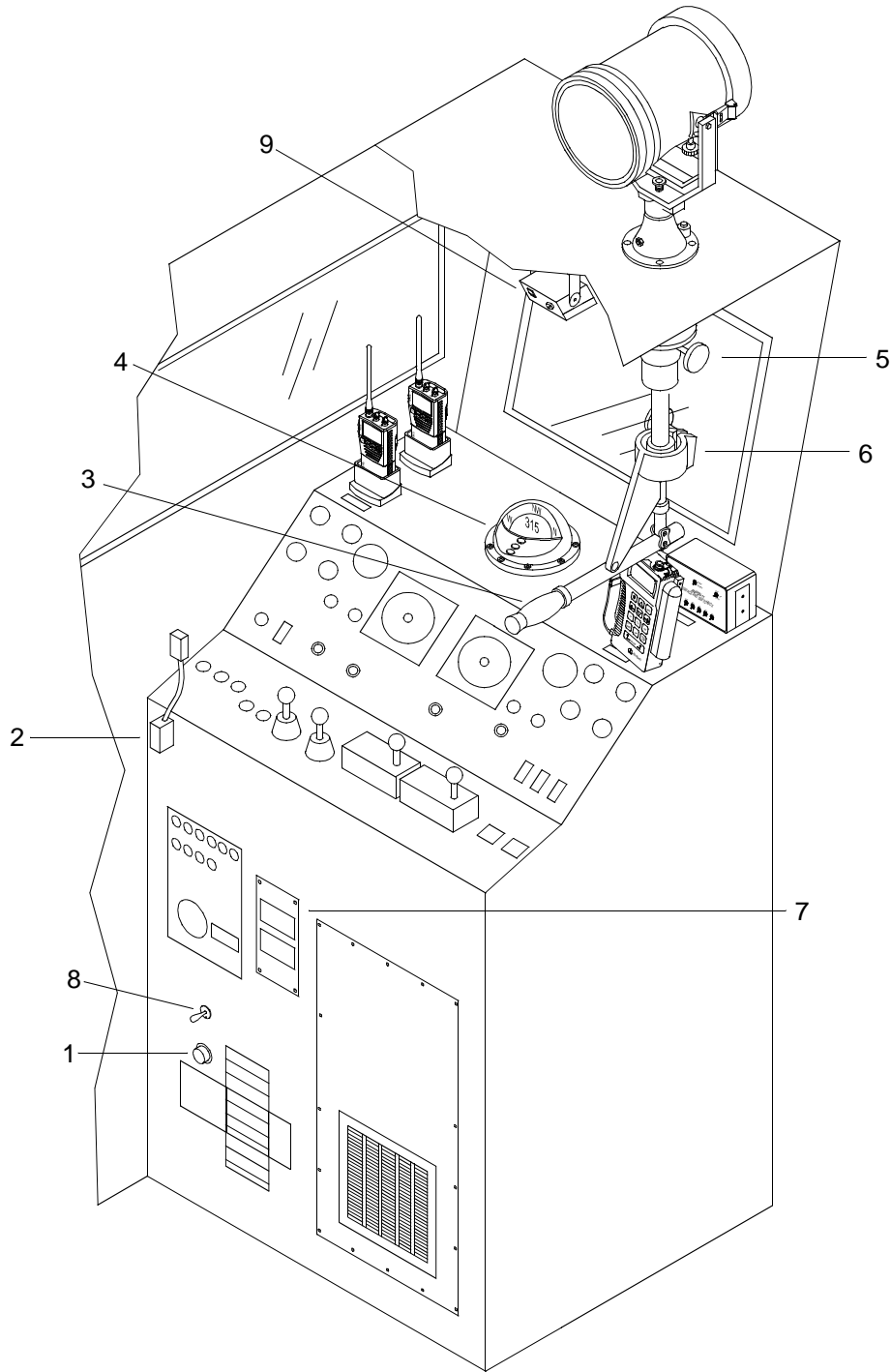


Table 13. Accessory Controls and Indicators.

KEY	CONTROL/INDICATOR	FUNCTION
1	Cab Heater Thermostat	Controls temperature inside operators cab.
2	Map Light Switch	Map light switch. Turns on/off and brighten/dims map light.

Table 13. Accessory Controls and Indicators. (Continued)

KEY	CONTROL/INDICATOR	FUNCTION
3	Grip Lever Control	Controls direction of spotlight.
4	Compass	Indicates direction of CF.
5	Ceiling Flange Knob	Holds vertical angle of spotlight to CF deck.
6	Ceiling Flange Knob	Holds left/right (port/starboard) position of spotlight.
7	Remote Control Switch	Indicates high current solenoid status and parallels battery banks for five minutes in emergency situations.
8	Cab Heater Fan Switch	Turns heater thermostat fan on and off.
9	Cab Heater/Windshield Defroster	Windshield defroster and secondary heat source.

DESCRIPTION OF OPERATOR CONTROLS AND INDICATORS DEFROSTER

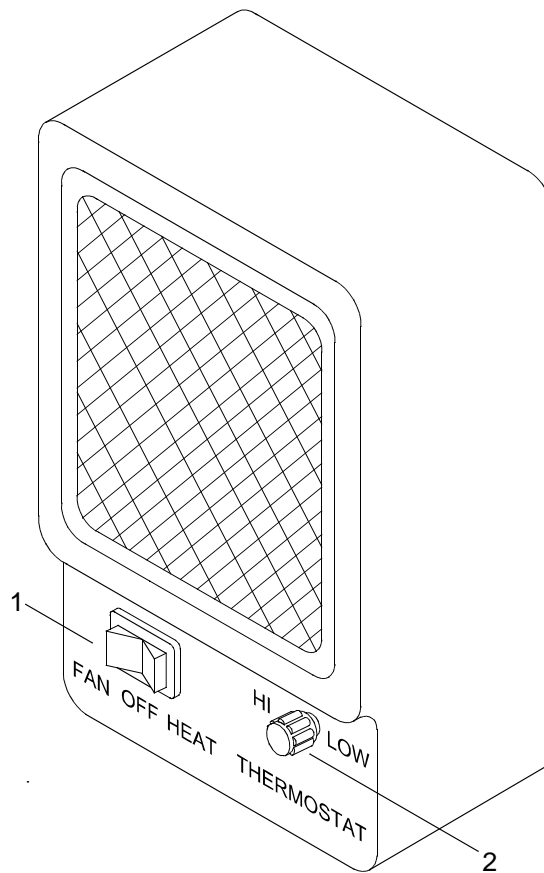


Table 14. Cab Defroster Controls and Indicators.

KEY	CONTROL/INDICATOR	FUNCTION
1	Function Select Switch	Three position switch. FAN position turns fan on. HEAT position turns heat and fan on. OFF position turns both heat and fan off inside operators cab.

Table 14. Cab Defroster Controls and Indicators. (Continued)

KEY	CONTROL/INDICATOR	FUNCTION
2	Thermostat Control	Controls temperature of defroster. Rotate right to increase temperature. Rotate left to reduce temperature.

DESCRIPTION OF OPERATOR CONTROLS AND INDICATORS, COMPASS

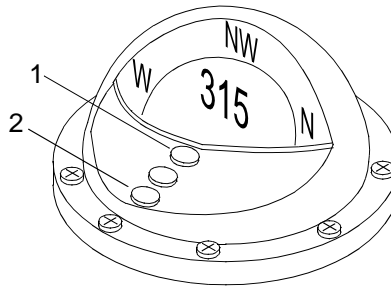


Table 15. Compass Controls and Indicators.

KEY	CONTROL/INDICATOR	FUNCTION
1	Mode Select Switch	Selects COMPASS mode.
2	Set Switch	Locks COMPASS mode.

BELOW DECK CONTROLS AND INDICATORS (OVERVIEW)

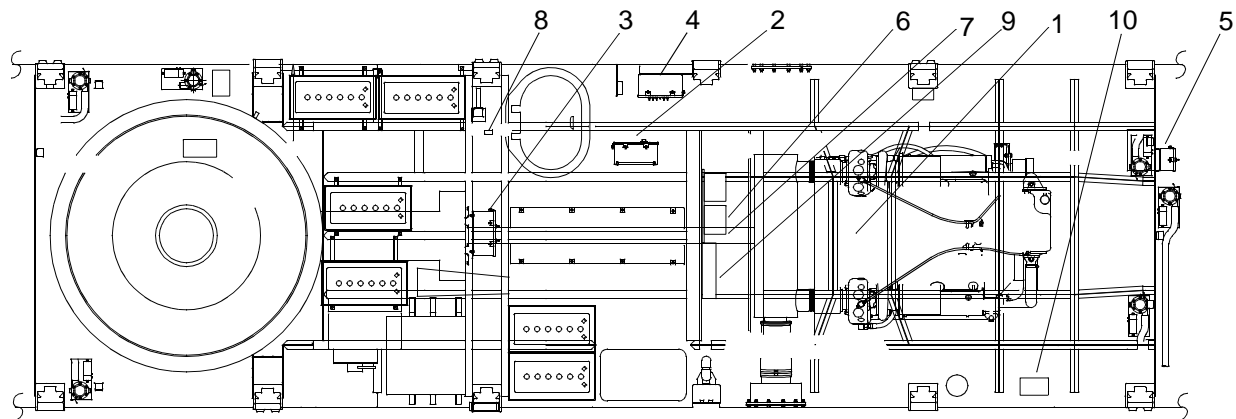


Table 16. Below Deck Controls and Indicators.

KEY	CONTROL/INDICATOR	FUNCTION
1	A1	The engine's actuator for speed governor, electronic overspeed switch, pressure switches, temperature and pressure sending units, etc. are wired to the engine in wire harness K-MB1.
2	A4	Engine Junction Box and E Stop Switch (E08913)
3	A5	Bilge Pump Control Panel (E08893)
4	A6	Propulsion Module Circuit Breaker Panel (E06793)

Table 16. Below Deck Controls and Indicators. (Continued)

KEY	CONTROL/INDICATOR	FUNCTION
5	A7	Single Bilge Pump Control Panel (E08903)
6	VR1	Voltage regulator monitors battery voltage and ambient temperature. Automatically compensates for over-temperature conditions by reducing field output.
7	BATTERY SELECTOR SWITCH	Four position rotary switch that controls which battery bank is utilized and provides protection to the alternator when engine is accidently shut down. ALL position not used.
8	Below Deck Lighting On/Off Switch	Up (ON)/Down (OFF) Controls electrical power to below deck lighting.
9	Breaker, 24VDC 50AMP	Controls power to the operators cab.
10	NORMAL STOP Switch	When depressed and held down, the fuel supply is cut off, stopping the engine.

DESCRIPTION OF OPERATOR CONTROLS AND INDICATORS, DIESEL ENGINE

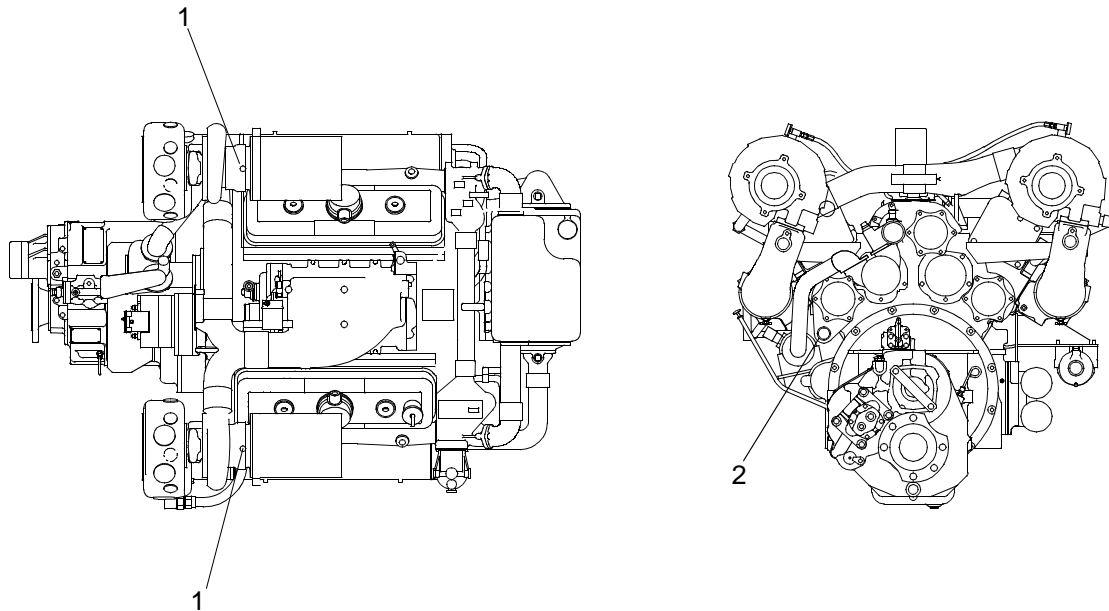


Table 17. Diesel Engine Controls and Indicators.

KEY	CONTROL/INDICATOR	FUNCTION
1	Air Inlet Restriction Indicators	Red button pops out when filters need to be changed. Each turbocharger has one indicator.
2	Engine Hour Meter	Totals hours the engine has operated. Hours are entered in the engine logbook.

**DESCRIPTION OF OPERATOR CONTROLS AND INDICATORS, PROPULSION
MODULE CIRCUIT BREAKER PANEL (A6)**

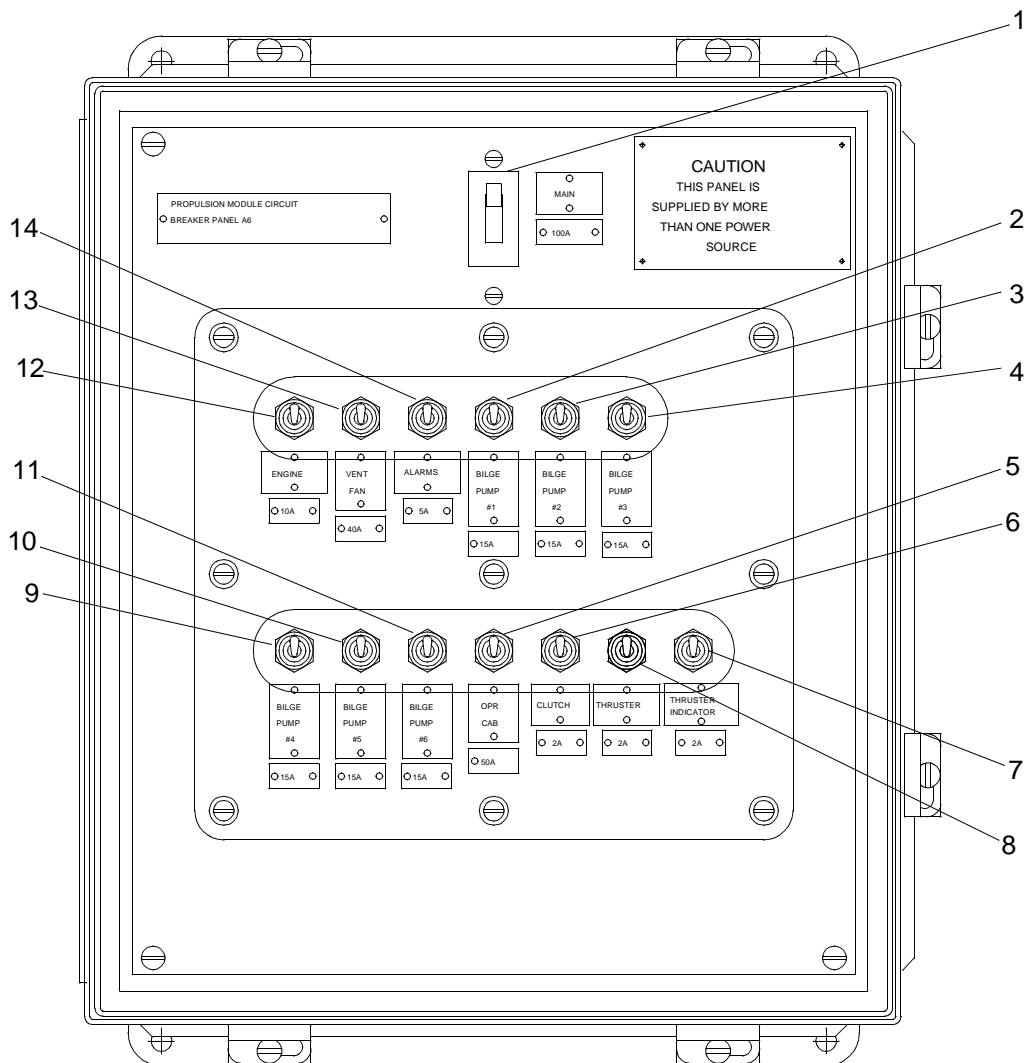


Table 18. Propulsion Module Circuit Breaker Panel (A6) Controls and Indicators.

KEY	CONTROL/INDICATOR	FUNCTION
1	MAIN Circuit Breaker, 100A	Up (On)/Down (Off) = Controls electrical power distribution below deck.
2	BILGE PUMP #1 Circuit Breaker, 15A	Up (On)/Down (Off) = Controls electrical power to operators cab for lazaret bilge pump #1 (located on lower control panel).
3	BILGE PUMP #2 Circuit Breaker, 15A	Up (On)/Down (Off) = Controls electrical power to operators cab for fwd port machinery compartment bilge pump #2 (located on lower control panel).
4	BILGE PUMP #3 Circuit Breaker, 15A	Up (On)/Down (Off) = Controls electrical power to operators cab for fwd stbd machinery compartment bilge pump #3 (located on lower control panel).
5	OPR CAB Circuit Breaker, 50A	NOT USED.

■ **Table 18. Propulsion Module Circuit Breaker Panel (A6) Controls and Indicators.**

KEY	CONTROL/INDICATOR	FUNCTION
6	CLUTCH Circuit Breaker, 2A	Up (On)/Down (Off) = Controls electrical power to operators cab for port and starboard clutch engagement switches (located on lower control panel).
7	THRUSTER INDICATOR Circuit Breaker, 2A	Up (On)/Down (Off) = Controls electrical power to operators cab for port and starboard pump-jet thruster direction indicators (located on middle control panel).
8	THRUSTER Circuit Breaker, 2A	Up (On)/Down (Off) = Controls electrical power to operators cab for port and starboard pump-jet thruster steering control joystick levers (located on lower control panel).
9	BILGE PUMP #4 Circuit Breaker, 15A	Up (On)/Down (Off) = Controls electrical power to operators cab for center port machinery compartment bilge pump #4 (located on lower control panel).
10	BILGE PUMP #5 Circuit Breaker, 15A	Up (On)/Down (Off) = Controls electrical power to operators cab for aft stbd machinery compartment bilge pump #5 (located on lower control panel).
11	BILGE PUMP #6 Circuit Breaker, 15A	Up (On)/Down (Off) = Controls electrical power to operators cab for aft port machinery compartment bilge pump #6 (located on lower control panel).
12	ENGINE Circuit Breaker, 10A	Up (On)/Down (Off) = Controls electrical power to operators cab for engine START/STOP switches port and starboard (Located on middle control panel).
13	VENT FAN Circuit Breaker, 40A	Up (On)/Down (Off) = Controls electrical power to operators cab for vent fan switches port and starboard (Located on lower control panel).
14	ALARMS Circuit Breaker, 5A	Up (On)/Down (Off) = Controls electrical power to operators cab for alarm system switches port and starboard (located on middle and lower control panels).

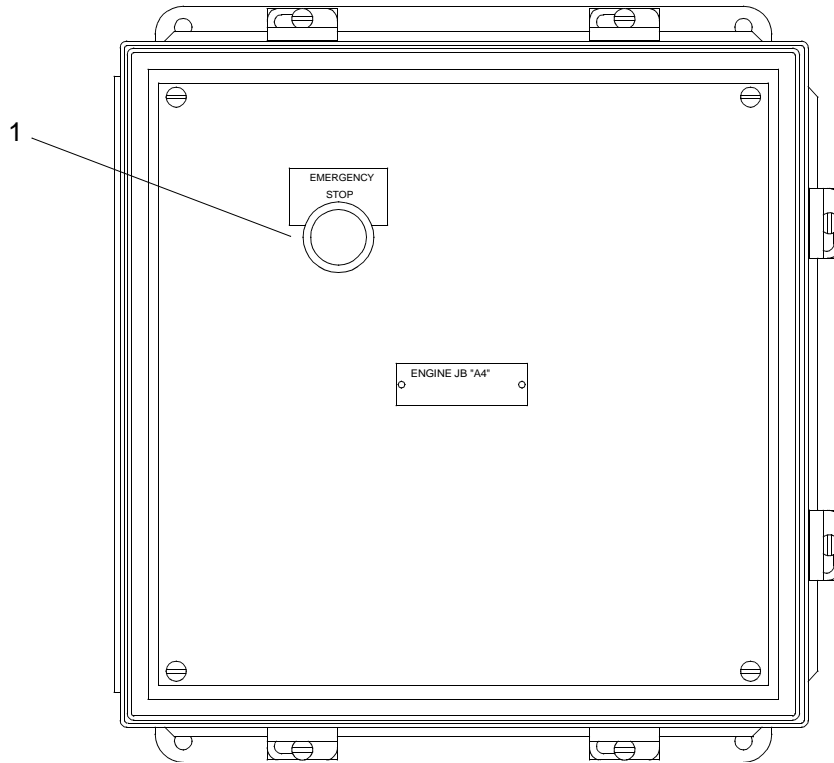
DESCRIPTION OF OPERATOR CONTROLS AND INDICATORS, ENGINE JUNCTION BOX ASSEMBLY (A4)


Table 19. Engine Junction Box Assembly (A4).

KEY	CONTROL/INDICATOR	FUNCTION
1	Engine EMERGENCY STOP (Red) Pushbutton	When depressed, closes air shut off valve to eliminate air supply to engine, stopping engine. This should only be used in extreme emergency.

DESCRIPTION OF OPERATOR CONTROLS AND INDICATORS, A10 PANEL

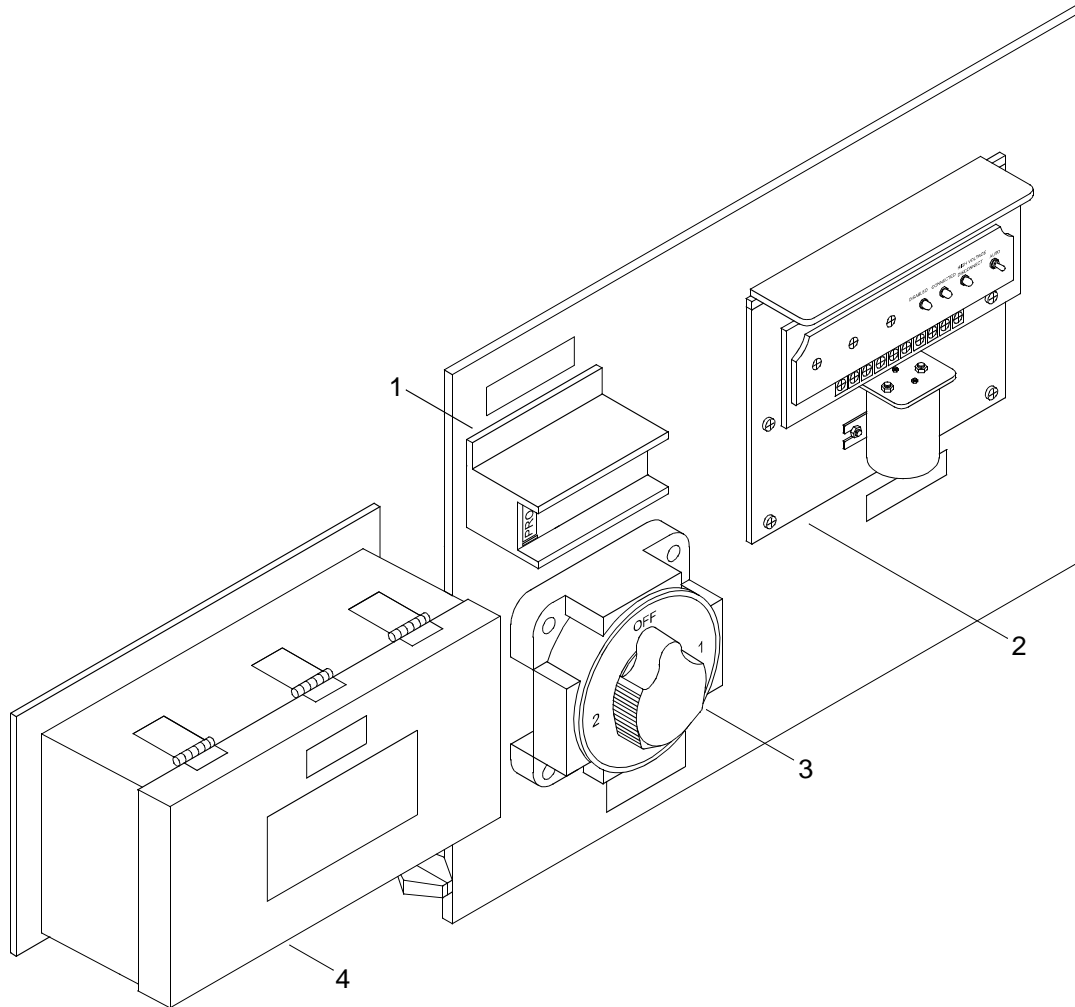
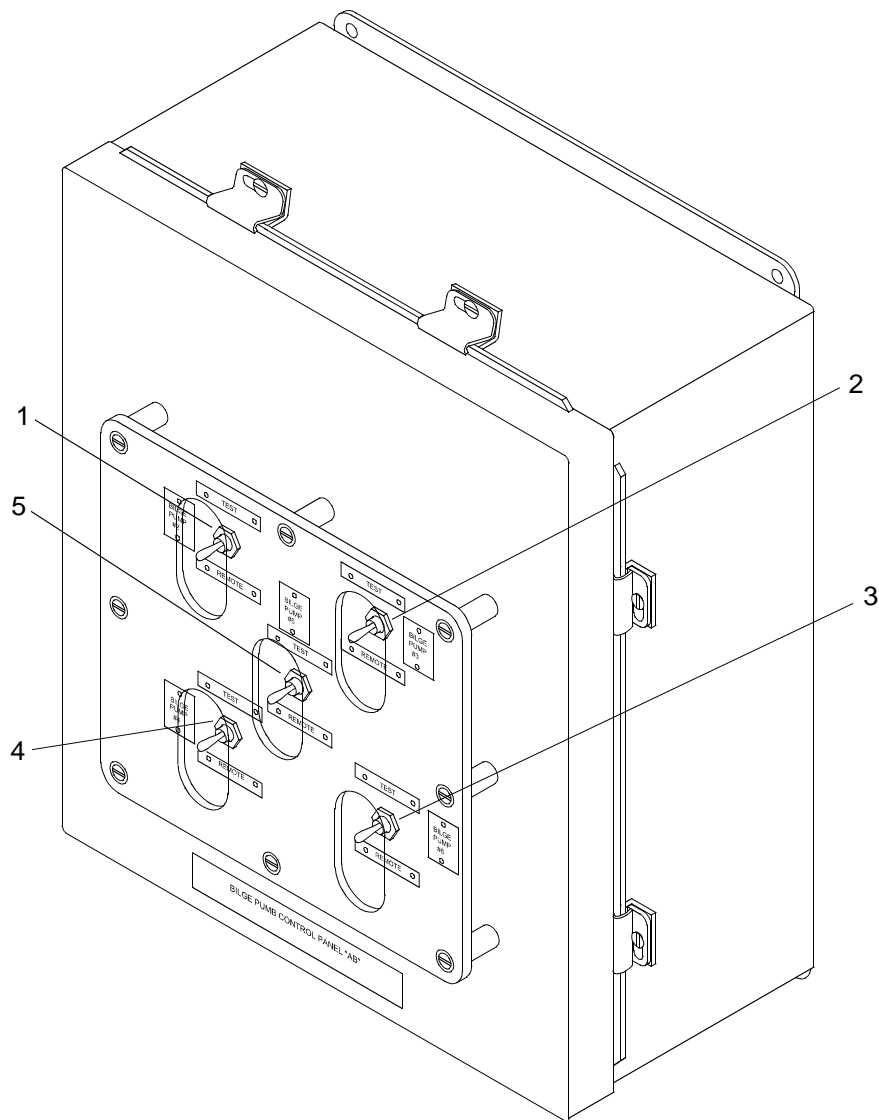


Table 20. Propulsion Module A10 Panel.

KEY	CONTROL/INDICATOR	FUNCTION
1	Voltage Regulator	Monitors battery voltage and automatically ensures batteries receive a full charge.
2	High Current Solenoid Multi-Battery Isolator	Automatically connects multiple batteries. Disconnects the starting batteries from system loads, when active charging sources are not available.
3	Battery Selector Switch	Allows switching from battery bank 1 to battery bank 2.
4	50 Amp Breaker 24 VDC	Controls power to operators cab.

DESCRIPTION OF OPERATOR CONTROLS AND INDICATORS, BILGE PUMP CONTROL PANEL ASSEMBLY (A5)


■ **Table 21. Bilge Pump Control Panel Assembly (A5) Controls and Indicators.**

KEY	CONTROL/INDICATOR	FUNCTION
1	BILGE PUMP #2 Toggle Switch	TEST = allows momentary, local operation of bilge pump #2 located fwd port in machinery compartment. REMOTE = allows operation from operators cab.
2	BILGE PUMP #3 Toggle Switch	TEST = allows momentary, local operation of bilge pump #3 located fwd stbd in machinery compartment. REMOTE = allows operation from operators cab.
3	BILGE PUMP #5 Toggle Switch	TEST = allows momentary, local operation of bilge pump #5 located aft stbd in machinery compartment. REMOTE = allows operation from operators cab.

■ **Table 21. Bilge Pump Control Panel Assembly (A5) Controls and Indicators. (Continued)**

KEY	CONTROL/INDICATOR	FUNCTION
4	BILGE PUMP #4 Toggle Switch	TEST = allows momentary, local operation of bilge pump #4 located center port in machinery compartment. REMOTE = allows operation from operators cab.
5	BILGE PUMP #6 Toggle Switch	TEST = allows momentary, local operation of bilge pump #6 located aft port in machinery compartment. REMOTE = allows operation from operators cab.

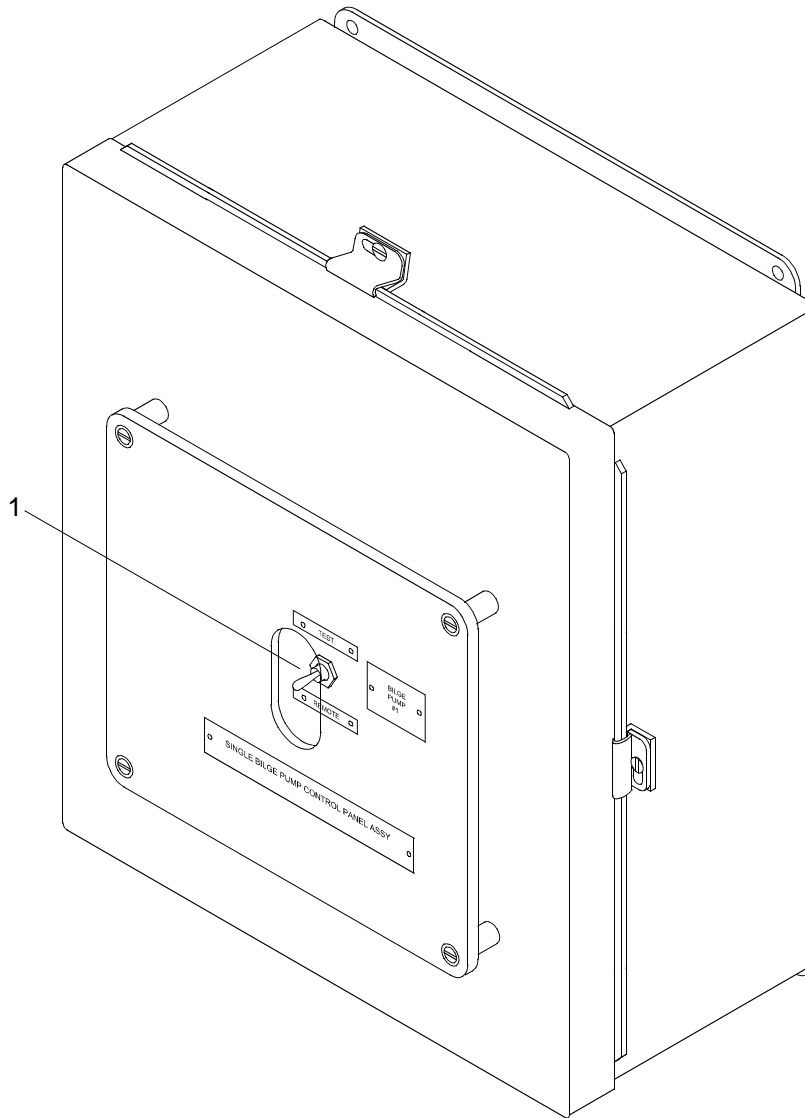
DESCRIPTION OF OPERATOR CONTROLS AND INDICATORS, SINGLE BILGE PUMP CONTROL PANEL ASSEMBLY (A7)


Table 22. Single Bilge Pump Control Panel Assembly (A7) Controls and Indicators.

KEY	CONTROL/INDICATOR	FUNCTION
1	BILGE PUMP #1 Toggle Switch	TEST = allows momentary, local operation of bilge pump #1 in lazaret compartment. REMOTE = allows operation from operators cab.

DESCRIPTION OF OPERATOR CONTROLS AND INDICATORS, HYDRAULIC STEERING SYSTEM

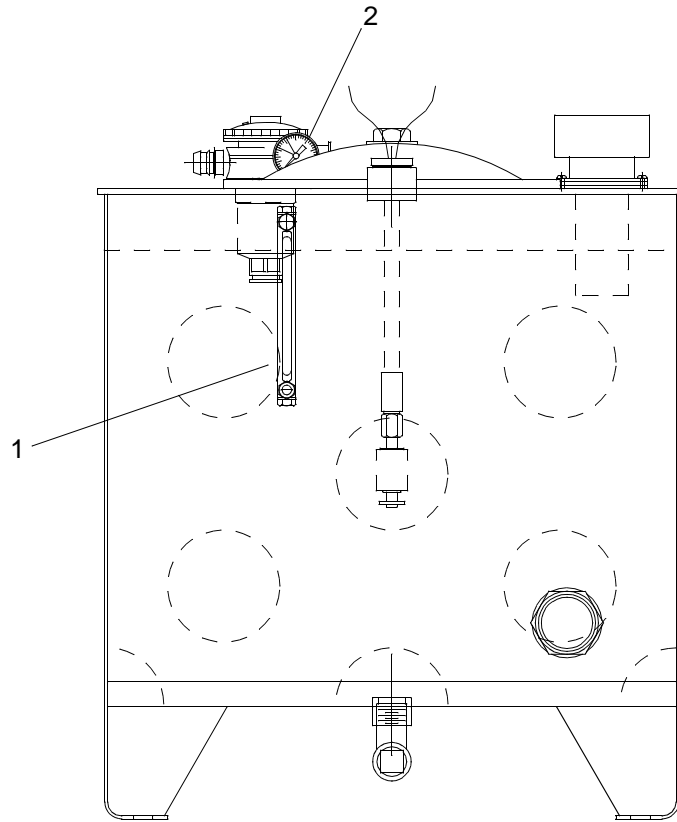
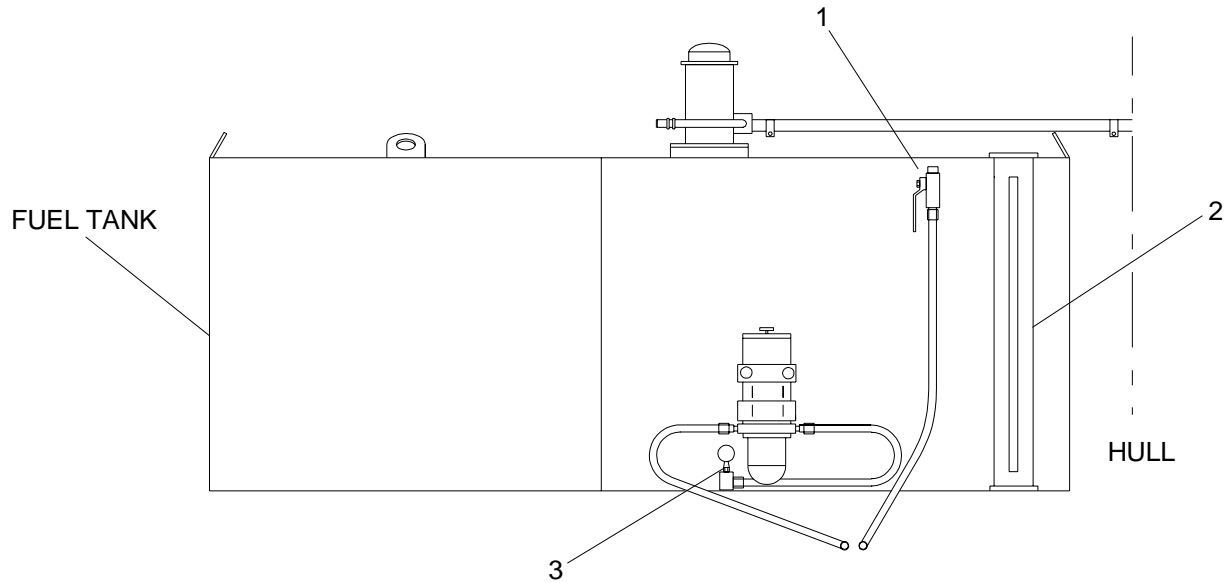


Table 23. Hydraulic System Controls and Indicators.

KEY	CONTROL/INDICATOR	FUNCTION
1	Sight Gauge	Indicates the level of hydraulic fluid in the storage reservoir.
2	Dirt Indicator, Return Filter	Indicates that when the arrow is in the red zone, the hydraulic reservoir fluid filter is dirty and needs replacing.

DESCRIPTION OF OPERATOR CONTROLS AND INDICATORS, FUEL SYSTEM



FUEL SYSTEM CONTROLS

■ **Table 24. Fuel System Controls and Indicators.**

KEY	CONTROL/INDICATOR	FUNCTION
1	Fuel Ball Valve (Return)	Allows return of unused fuel back into fuel tank.
2	Sight Gauge	Indicates level of fuel in the fuel tank.
3	Fuel Ball Valve (Supply)	Allows fuel to be transferred to the diesel engine.

DESCRIPTION OF OPERATOR CONTROLS AND INDICATORS, RAW WATER SYSTEM

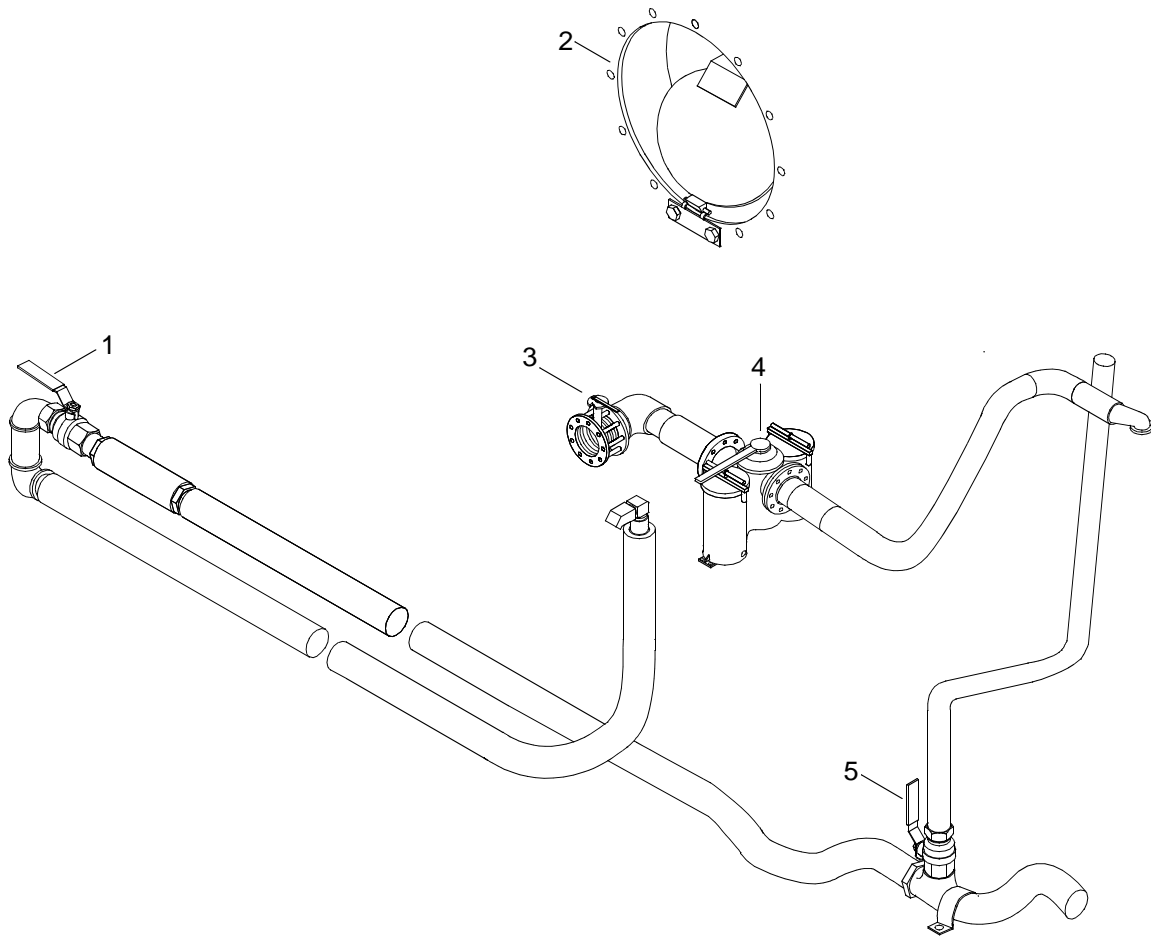
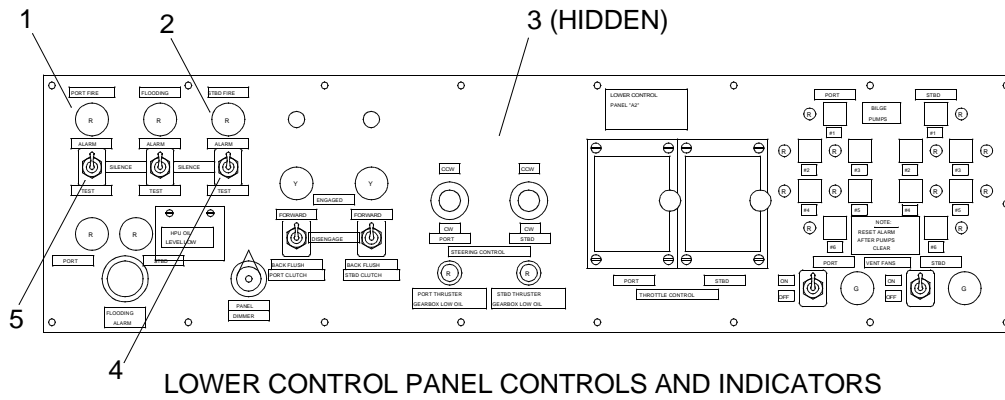


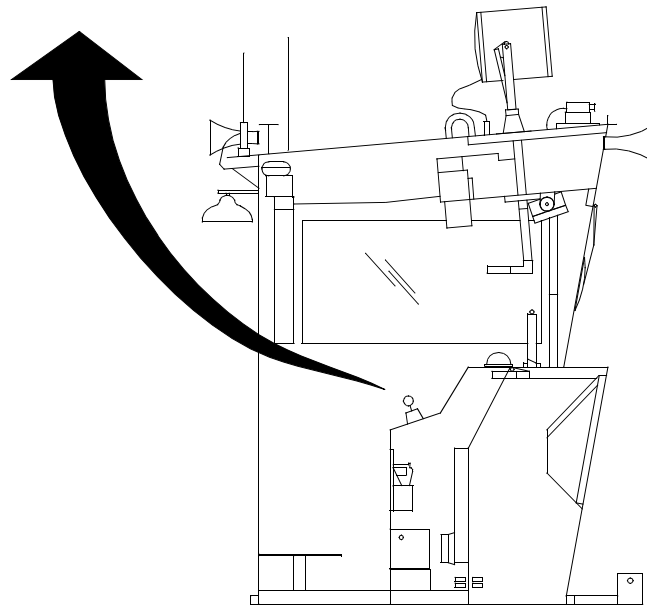
Table 25. Raw Water System Controls and Indicators.

KEY	CONTROL/INDICATOR	FUNCTION
1	Raw Water System Transfer Case Valve	Allows the flow of raw water into the transfer case.
2	Exhaust Port Flapper Latch	Holds flapper closed when the powered module is not in use.
3	Seachest Butterfly Valve	When in the OPEN position, allows sea water to be drawn from the seachest into the raw water cooling system.
4	Duplex Strainer Valve	Selects between two strainer baskets. This allows on-the-run changing of strainers if one strainer becomes clogged. In center position, water is drawn through both at the same time.
5	Raw Water System Exhaust Valve	Allows the flow of raw water into the exhaust system.

DESCRIPTION OF OPERATOR CONTROLS AND INDICATORS, FIRE DETECTION SYSTEM



4 LOWER CONTROL PANEL CONTROLS AND INDICATORS



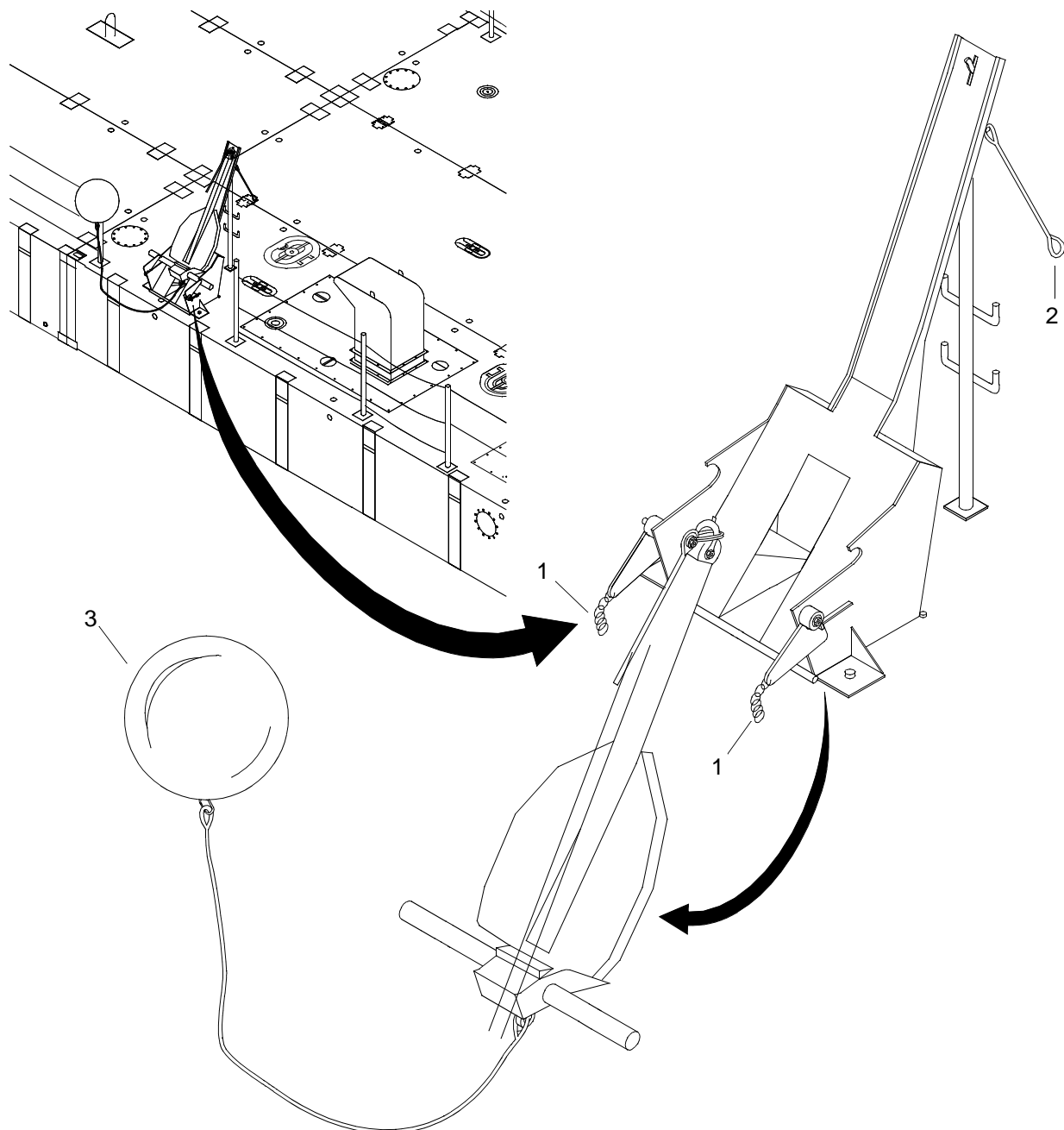
FIRE DETECTION CONTROLS AND INDICATORS

Table 26. Fire Detection System Controls and Indicators.

KEY	CONTROL/INDICATOR	FUNCTION
1	PORT FIRE Alarm Red Indicating Light	Illuminates when port side thermal detector senses 225°F.
2	STBD FIRE Alarm Red Indicating Light	Illuminates when port side thermal detector senses 225°F.
3	ALARM Horn	Horn sounds when thermal detectors sense ambient temperature of 225°F in either propulsion module.

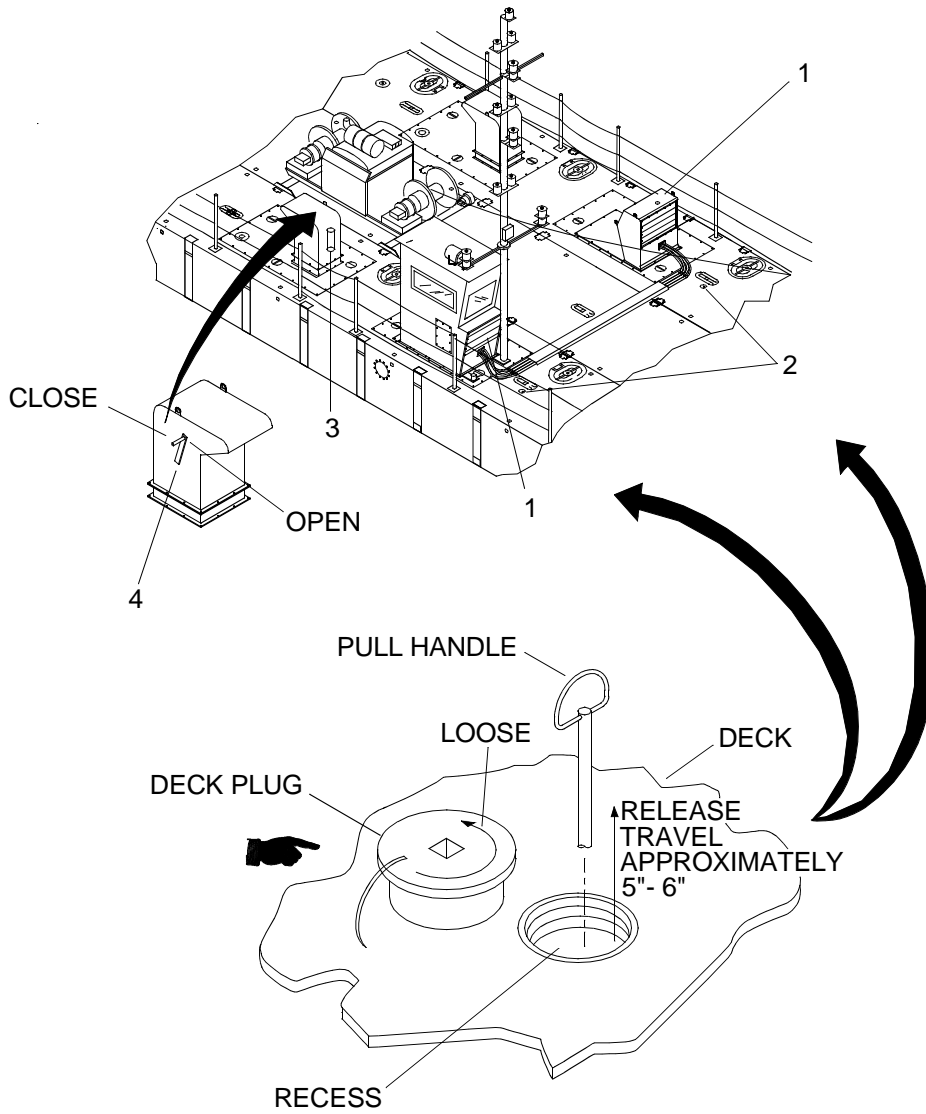
■ **Table 26. Fire Detection System Controls and Indicators. (Continued)**

KEY	CONTROL/INDICATOR	FUNCTION
4	STBD FIRE ALARM/SILENCE/ TEST Toggle Switch	Audible alarm (horn) indicates below deck temperature above 225°F or possible onboard fire in starboard propulsion module. ALARM = horn sounds and red light on in operators cab. SILENCE = alarm horn silenced, red light remains on. TEST (momentary) = alarm horn sounds and red light on. Reset to ALARM when normal conditions exist.
5	PORT FIRE ALARM/SILENCE/ TEST Toggle Switch	Audible alarm (horn) indicates below deck temperature above 225°F or possible onboard fire in port propulsion module. ALARM = alarm horn sounds and red light on in operators cab. SILENCE = alarm horn silenced, red light remains on. TEST (momentary) = alarm horn sounds and red light on. Reset to ALARM when normal conditions exist.

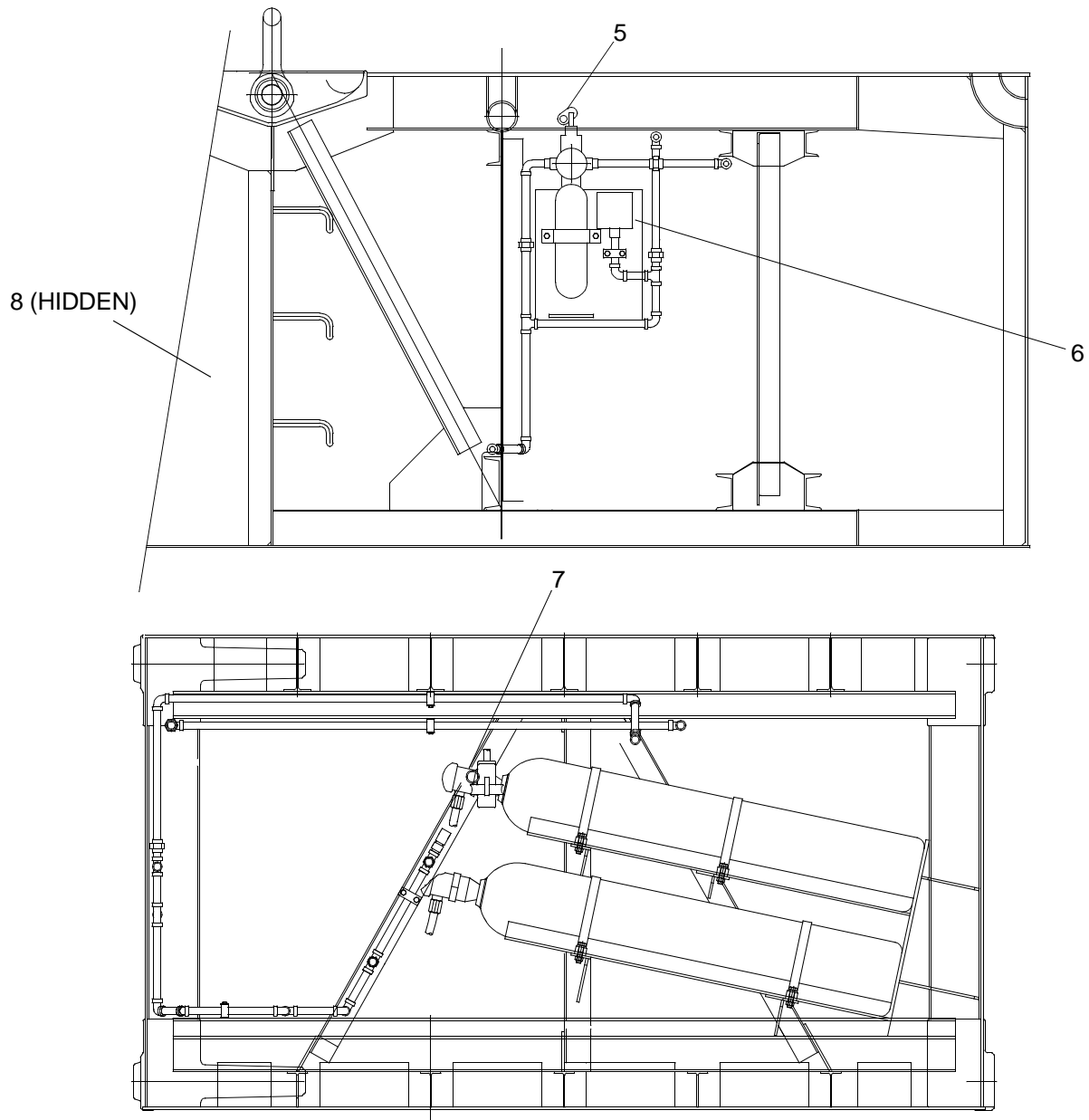
**DESCRIPTION OF OPERATOR CONTROLS AND INDICATORS,
ANCHORBOARD ASSEMBLY**

Table 27. Anchorboard Assembly Controls and Indicators.

KEY	CONTROL/INDICATOR	FUNCTION
1	Locking Chains	Two chains lock ramp extensions in the up (stowed) position, preventing accidental deployment. When chains are lifted from holding brackets, ramps are free to fall down and forward to deploy anchor.
2	Release Lanyard	Pull to actuate the hook release and anchor will immediately deploy.
3	Marker Buoy	Attached to the anchor when deployed, marks the anchor's location for retrieval.

DESCRIPTION OF OPERATOR CONTROLS AND INDICATORS, FIRE SUPPRESSION SYSTEM



FIRE SUPPRESSION AND INDICATORS



FIRE SUPPRESSION CONTROLS AND INDICATORS

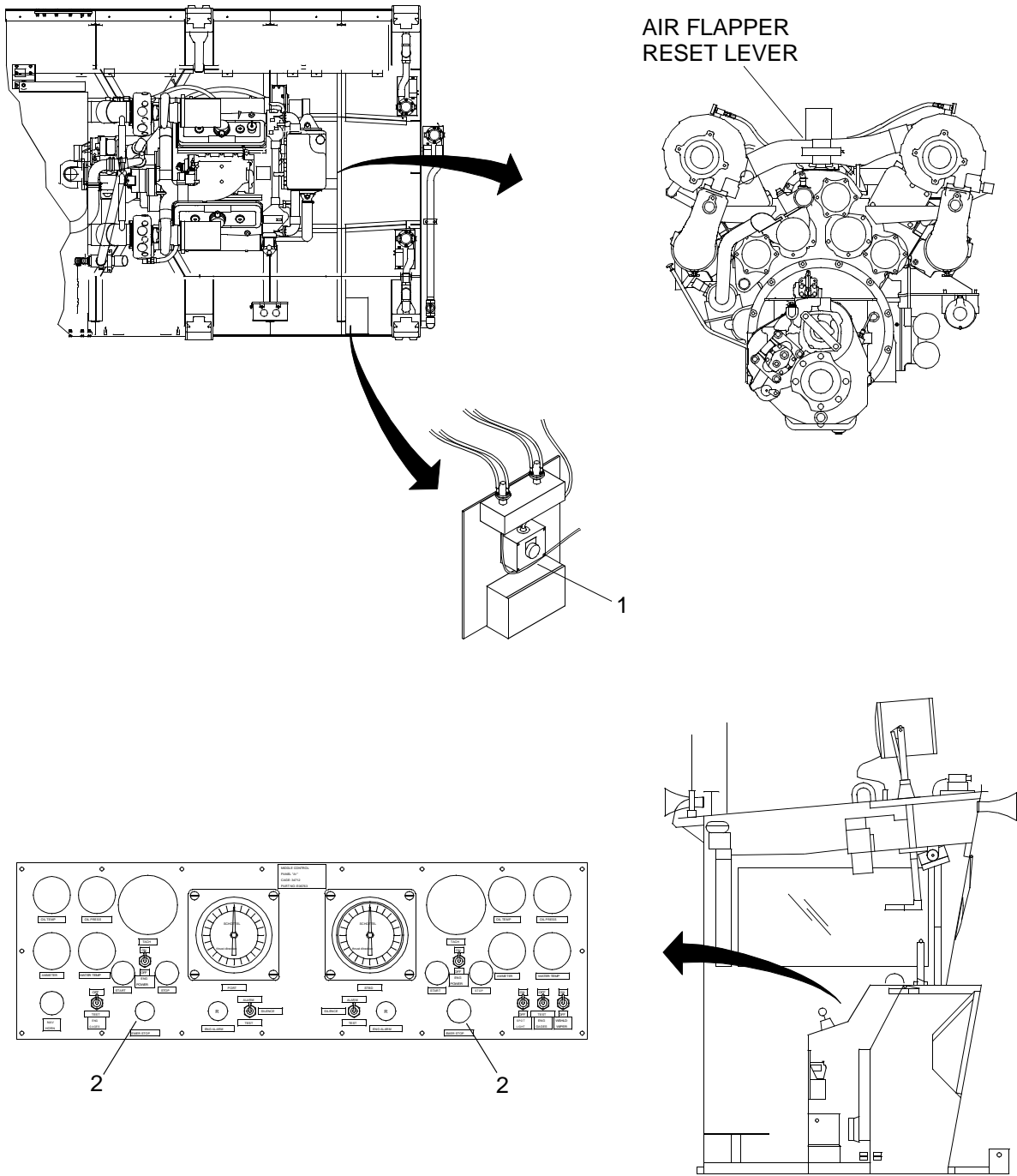
Table 28. Fire Suppression System Controls and Indicators.

KEY	CONTROL/INDICATOR	FUNCTION
1	Air Intake Plenum	CO2 pressure automatically actuates the pressure trip mechanism to close vent flap. Vent flap must be manually reset to open position before resuming normal operation.
2	Remote Cable Pull Handle	Pull handle, fire suppression system activated, 30 seconds later CO2 will discharge.

Table 28. Fire Suppression System Controls and Indicators. (Continued)

KEY	CONTROL/INDICATOR	FUNCTION
3	Portable Fire Extinguisher	Located on the exhaust plenum aft of operators cab. Point nozzle at base of flame, remove lock pin and squeeze handle.
4	Exhaust Plenum Vent Control Handle	Place handle in CLOSED position to shut off oxygen source.
5	Control Head Lever, Time Delay	Pull pin, pull lever, fire suppression system activated. 30 seconds later CO2 will discharge.
6	Pressure Switch	Senses pressure and actuates engine emergency stop. Must be manually reset when normal conditions exist.
7	Control Head Lever, 50 lb Bottle with Safety Pin	Pull pin, pull lever, fire suppression system activated. 30 seconds later CO2 will discharge.
8	Alarm Siren	Siren in machinery compartment activated by CO2 pressure.

**DESCRIPTION OF OPERATOR CONTROLS AND INDICATORS, DIESEL ENGINE
EMERGENCY STOP**

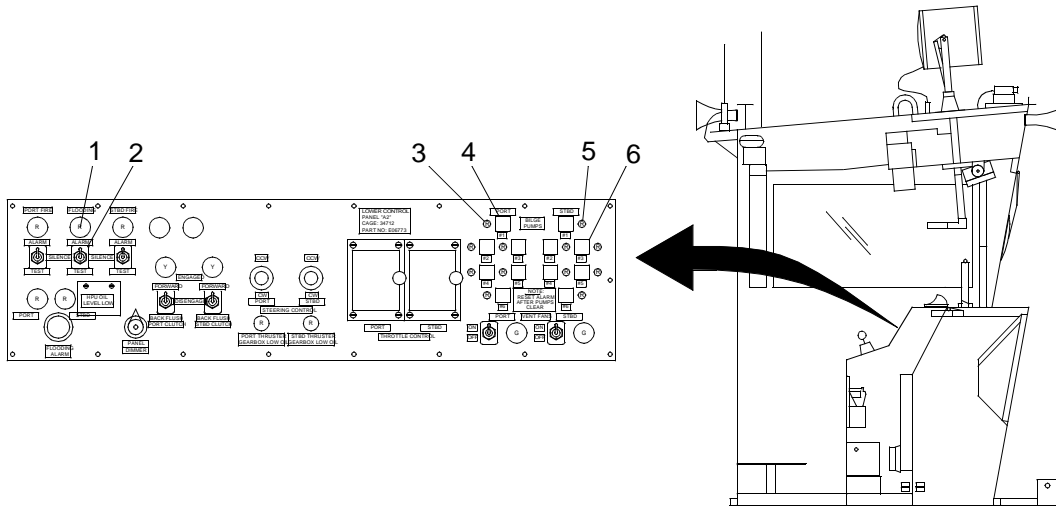


DIESEL ENGINE EMERGENCY STOP LOCATIONS

Table 29. Diesel Engine Emergency Stop Controls and Indicators.

KEY	CONTROL/INDICATOR	FUNCTION
1	EMERGENCY STOP - Engine Junction Box Assembly (A4)	When red pushbutton is depressed, the air shut off valve closes, stopping engine.
2	EMER STOP Pushbutton, Middle Control Panel (Port and Starboard)	When red pushbutton is depressed, it closes the air shut off valve, stopping engine.

DESCRIPTION OF OPERATOR CONTROLS AND INDICATORS, BILGE PUMP SYSTEM



BILGE PUMP SYSTEM CONTROLS AND INDICATORS

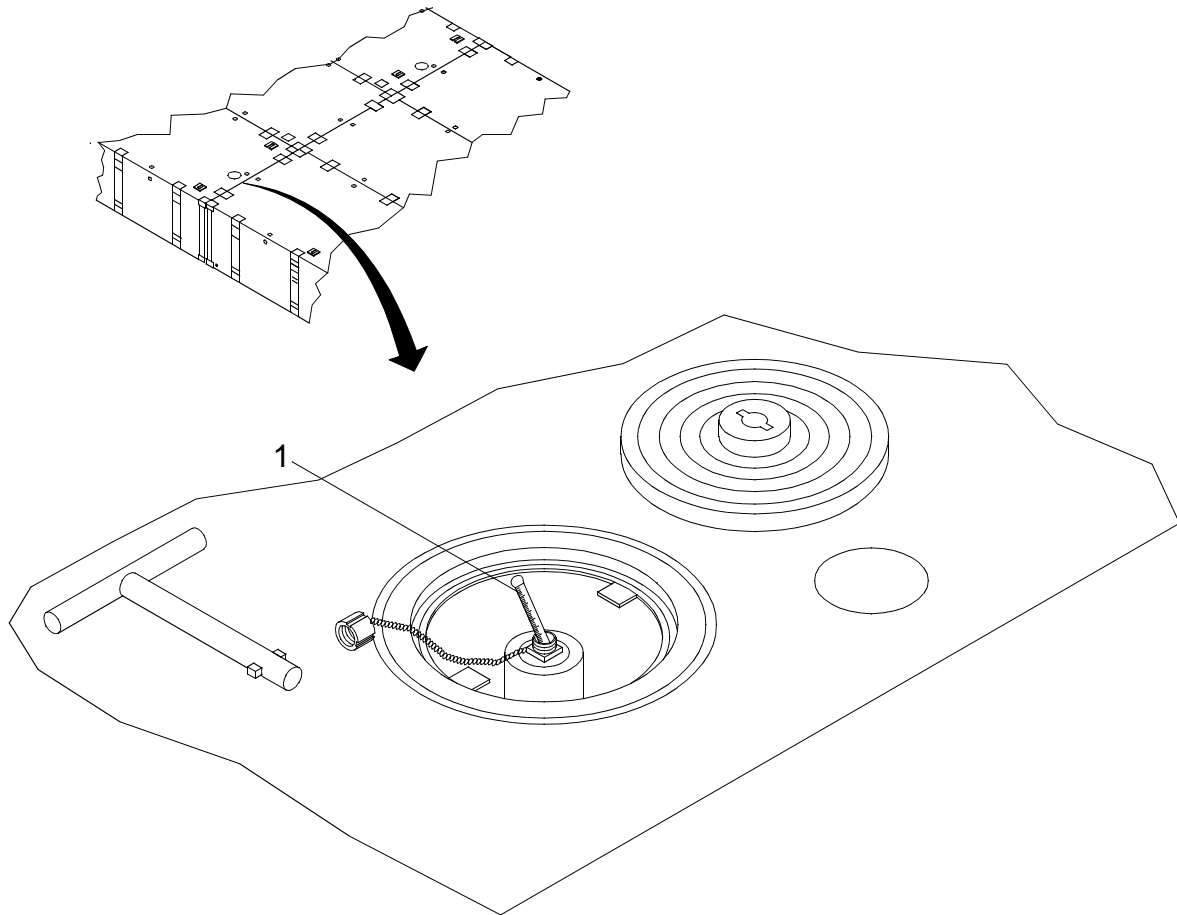
Table 30. Bilge Pump System Controls and Indicators.

KEY	CONTROL/INDICATOR	FUNCTION
1	FLOOD ALARM Red Indicator Light	Illuminates when a bilge pump float switch is actuated. Illuminates until bilge pump float switch is deactivated, indicating dry bilges.
2	FLOODING ALARM SILENCE/TEST Toggle Switch	Audible alarm (pulse beeper) indicates possible flooding in port and/or starboard propulsion module. ALARM = pulse beeper sounds and red light on. SILENCE = pulse beeper is silenced, red light on. TEST (momentary) = pulse beeper sounds, red light on. Reset to ALARM when normal conditions exist.
3	PORT BILGE PUMP(s) Red Indicator Light(s)	Light(s) will illuminate indicating flooded bilge location(s) within the port side propulsion module via activated bilge pump float switch(s).
4	PORT BILGE PUMP Pushbutton(s) with Green Indicator Light(s)	Controls operation of bilge pumps in port propulsion module, illuminates when depressed, indicating each pump is working. Allows any bilge pump to be energized that has a red illuminated light (flood location).

Table 30. Bilge Pump System Controls and Indicators. (Continued)

KEY	CONTROL/INDICATOR	FUNCTION
5	STBD BILGE PUMP(s) Red Indicator Light(s)	Light(s) will illuminate indicating flooded bilge location(s) within the stbd propulsion module via activated bilge pump float.
6	STBD PORT BILGE PUMP Pushbutton(s) with Green Indicator Light(s)	Controls operation of bilge pumps in starboard propulsion module, illuminates when depressed, indicating each pump is working. Allows any bilge pump to be energized that has a red illuminated light (flood location).

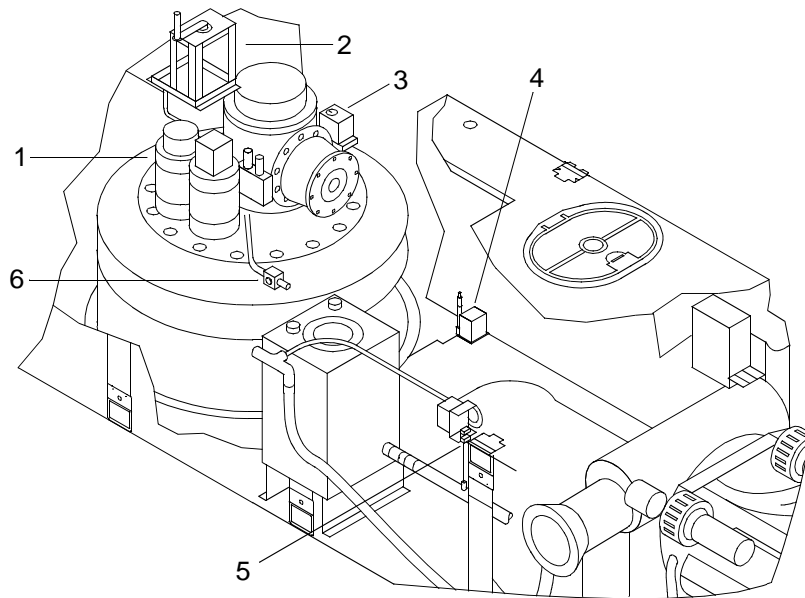
**DESCRIPTION OF OPERATOR CONTROLS AND INDICATORS, BILGE SYSTEM
SLUDGE TANK LEVEL INDICATOR**



■ Table 31. Bilge Tank System Controls and Indicators.

KEY	CONTROL/INDICATOR	FUNCTION
1	Sludge Tank Fluid Level Indicator	Stainless steel diptape (tape measure). Indicates amount of oily water in sludge tank.

DESCRIPTION OF OPERATOR CONTROLS AND INDICATORS, EMERGENCY SHIFTING AND STEERING



EMERGENCY SHIFTING AND STEERING CONTROLS AND INDICATORS

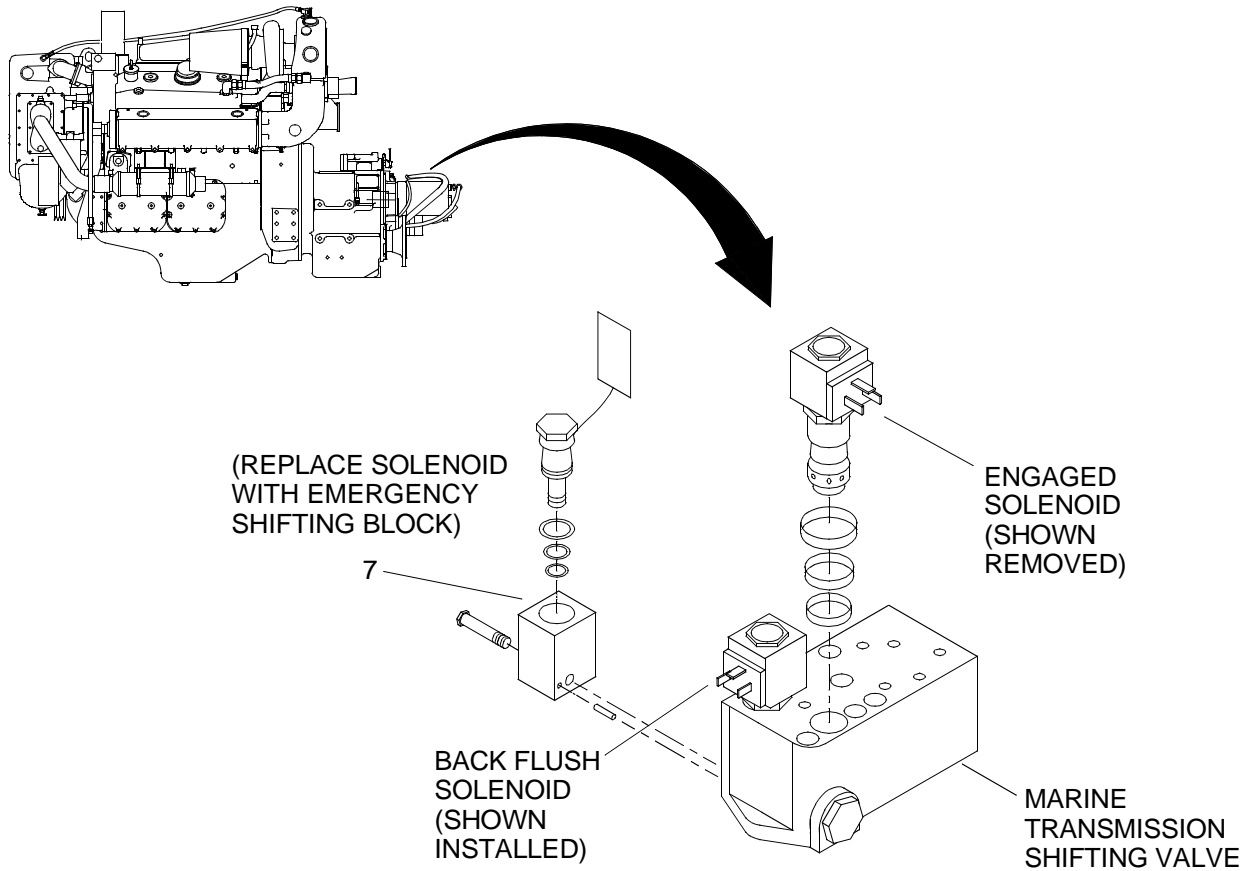


Table 32. Emergency Shifting and Steering Controls and Indicators.

KEY	CONTROL/INDICATOR	FUNCTION
1	Needle Valve	Normally closed, this valve opens to allow manual steering with the portable tiller arm.
2	Emergency Steering Handle	Found in lazaret compartment, this handle assembly is fitted with an assembly socket for the 1.5 in. square head on the top of the pump-jet steering motor so that the directional pump-jet thruster nozzle can be manually positioned clockwise or counter-clockwise in the event power is interrupted.
3	Feedback Unit	Mechanical link to the pump-jet nozzle and allows operator of steering handle assembly to observe positioning of pump-jet nozzle as it is being rotated.
4	Hand Pump	Generates the hydraulic pressure to release the pump-jet hydraulic brake.
5	Way-Valve	Allows manual override of steering controls.
6	3/2 Ball Valve	Accommodates hand pump by shutting off rest of system so hydraulic pressure generated by the hand pump goes directly to the hydraulic brake.
7	Emergency Shifting Block for Selector Valve	On marine gear, if electronic solenoid for either FORWARD or BACKFLUSH clutching becomes inoperative, it can be replaced with the emergency shifting block to open the required port, allowing hydraulic pressure flow to engage the clutch.

**OPERATOR MAINTENANCE
CAUSEWAY FERRY
MODULE ISOPAK
OPERATION UNDER USUAL CONDITIONS**

INITIAL SETUP:**Tools**

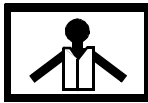
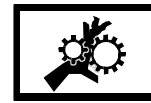
Tool Kit, General Mechanic's (Rail and Marine) (Item 76, WP 0105 00)
 Gloves, Men's and Women's (Leather Palm) (Item 31, WP 0105 00)
 Goggles, Sun, Wind and Dust (Safety) (Item 34, WP 0105 00)
 Life Preserver, Vest (Item 45, WP 0105 00)
 Helmet, Safety (Brown) (Item 40, WP 0105 00)
 Ladder (Item 43, WP 0105 00)
 Sling, Lifting, 8,400 lb (Yellow) (Item 72, WP 0105 00)
 Qty 4
 Sling, Lifting, 53,000 lb (Brown) (Item 67, WP 0105 00)
 Qty 2
 Sling, Lifting, 66,000 lb (Olive) (Item 71, WP 0105 00)
 Qty 2
 Sling, Lifting, 36,000 lb Adjustable Chain (Item 66, WP 0105 00)
 Qty 4

Personnel Required

Seaman 88K (2)

PREPARATION FOR USE - DISASSEMBLE MODULE ISOPAK**DISASSEMBLE NON-POWERED MODULE ISOPAK**

WARNING

**VEST****HELMET PROTECTION****HEAVY PARTS****MOVING PARTS**

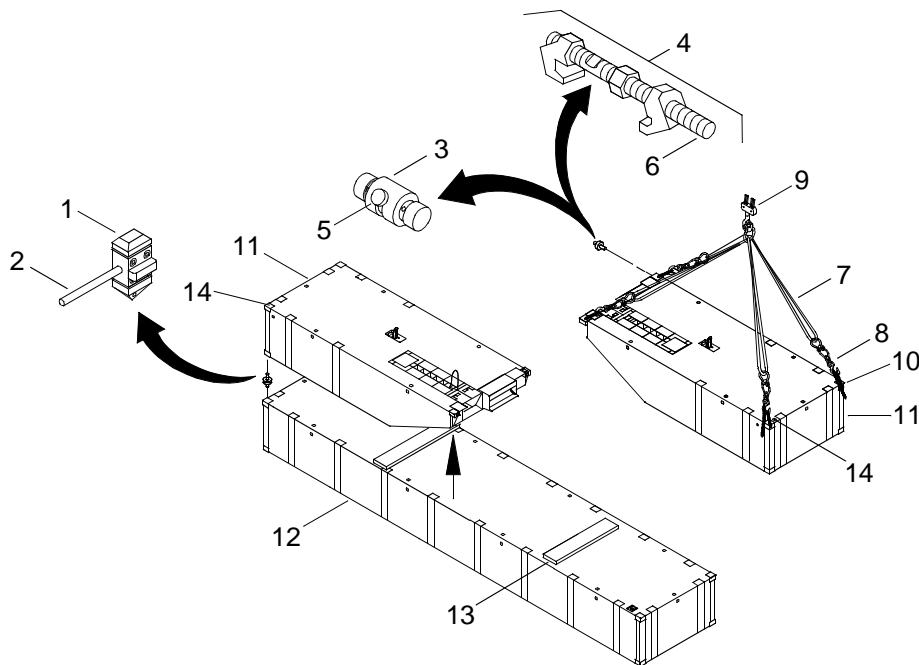
All personnel must wear personal flotation device, hard hat, safety shoes and gloves during CF operations and maintenance. Failure to observe these precautions could result in serious injury or death.

1. Using ladder, climb on top of module.

NOTE

Either horizontal twist locks or bridge locks are used to connect two end rake modules.

2. Unlock four vertical connectors (1) by rotating levers (2).



3. Unlock two horizontal twist locks (3) or bridge locks (4).
 - a. Unlock two horizontal twist locks (3) by rotating levers (5).
 - b. Unlock and remove two bridge locks (4) by loosening jack screws (6).

NOTE

Left and right modules are rigged and lifted in same manner.

4. Attach four 8,400 lb slings (7) and four 36,000 lb adjustable chain slings (8) from crane (9) to corners (10) on end rake module (11).
5. Descend from top of module and remove ladder.

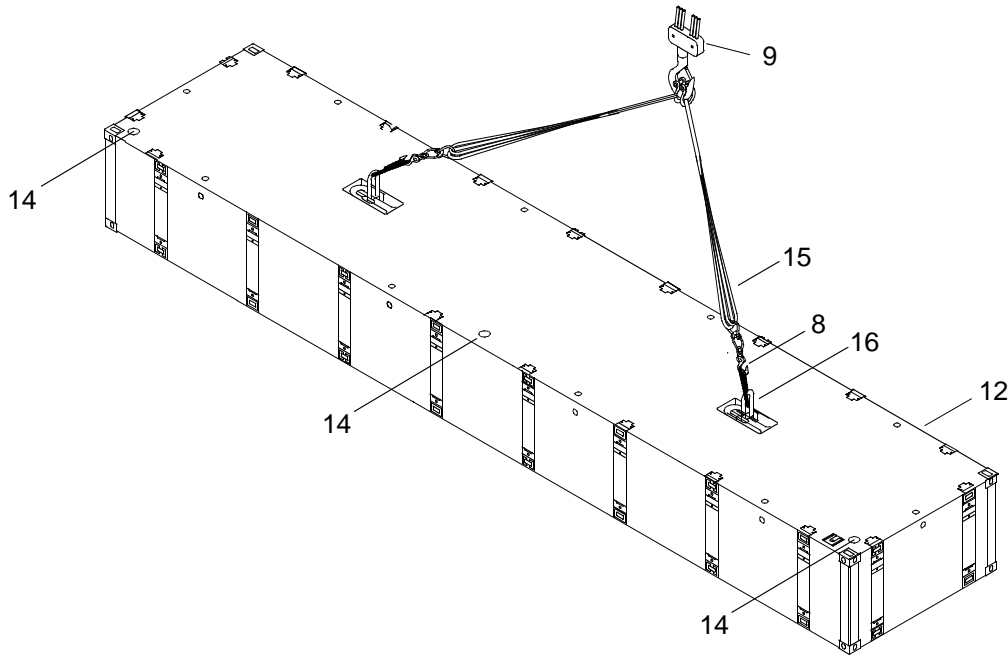
WARNING



HEAVY PARTS

6. Using slings (7 and 8) and crane (9), lift end rake module (11) from top of center module (12) and into position for modular string assembly.
7. Remove 8,400 lb slings (7) and 36,000 lb adjustable chain slings (8) from corners (10) on end rake module (11).
8. Remove vertical connectors (1) from corners of center module (12).

9. Remove horizontal twist locks (3) from end rake modules (11).
10. Remove dunnage (13) from top of center module (12).
11. Verify drain plugs (14) on end rake modules (11) are installed.
12. Attach two 53,000 lb slings (15) and two 36,000 lb adjustable chain slings (8) from crane (9) to padeyes (16) on center module (12).



WARNING

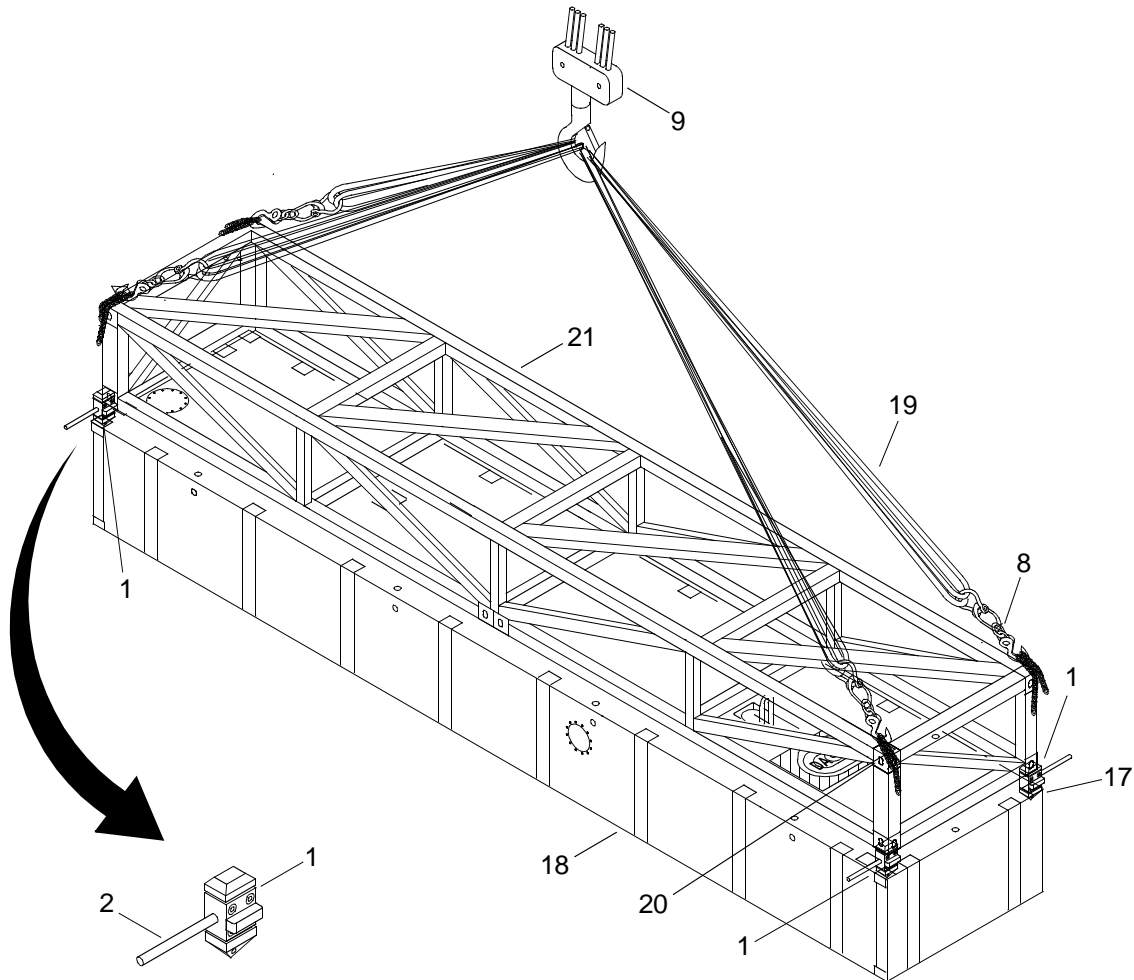

HEAVY PARTS

13. Using slings (8 and 15) and crane (9), lift center module (12) into position for assembly.
14. Remove 36,000 lb adjustable chain slings (8) from padeyes (16) on center module (12).
15. Remove 53,000 lb slings (15) from crane (9).
16. Verify drain plugs (14) on center module (12) are installed.

DISASSEMBLE POWERED MODULE ISOPAK - REMOVE EMPTY SHIPPING FRAME FROM POWERED MODULE ISOPAK

1. Unlock four ISOPAK vertical connectors (1) on corners (17) of powered module (18) by rotating lever (2).
2. Using ladder, climb up on top of module shipping frame.

3. Attach two 66,000 lb slings (19) and four 36,000 lb adjustable chain slings (8) from crane (9) to ISO corners (20) on shipping frame (21).



4. Descend from top of shipping frame (21) and remove ladder.

WARNING

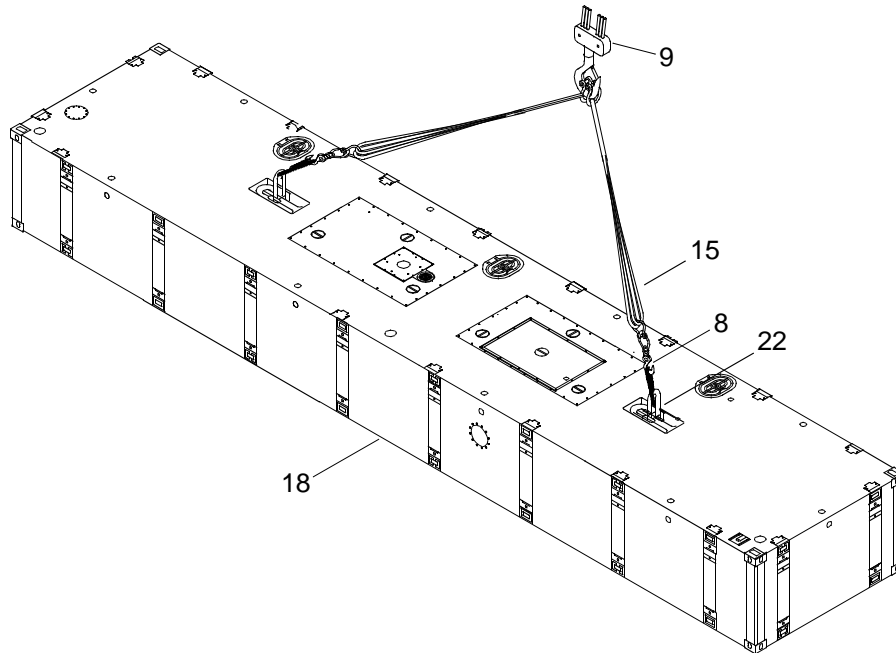


HEAVY PARTS

5. Using crane and slings, remove shipping frame (21) from power module (18).
6. Remove 36,000 lb adjustable chain slings (8) from ISO corners (20) on shipping frame (21).
7. Remove 66,000 lb slings (19) from crane (9).
8. Remove ISOPAK vertical connectors (1) from corners (17) of power module (18).

LIFT POWERED MODULE

1. Using ladder, climb on top of power module (18).
2. Attach two 53,000 lb slings (15) and two 36,000 lb adjustable chain slings (8) from crane (9) to padeyes (16) on power module (18).



3. Descend from top of module (18) and remove ladder.

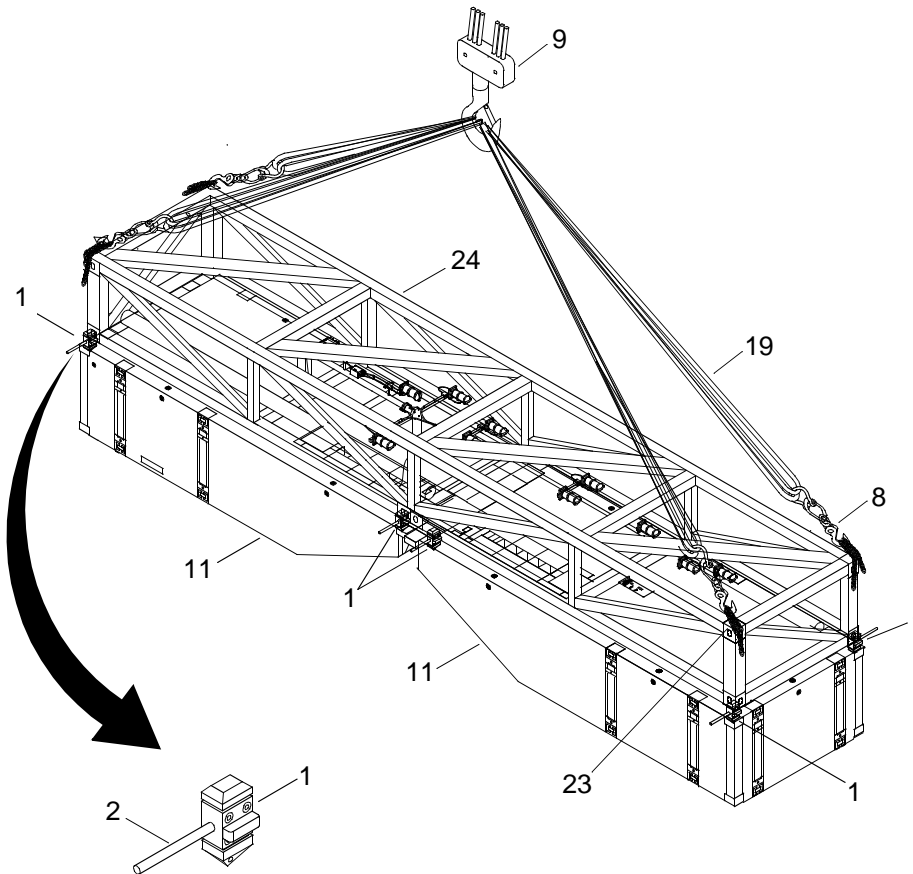
WARNING**HEAVY PARTS**

4. Using slings (8 and 15) and crane (9), lift power module (18) into position for assembly.
5. Remove 36,000 lb adjustable chain slings (8) from padeyes (22) on power module (18).
6. Remove 53,000 lb slings (15) from crane (9).

REMOVE MAIN MAST SHIPPING FRAME FROM END RAKE MODULE ISOPAK

1. Unlock eight ISOPAK vertical connectors (1) on corners of end rakes (11) by rotating lever (2).
2. Using ladder, climb on top of module ISOPAK.

- Attach two 66,000 lb slings (17) and four 36,000 lb adjustable chain slings (8) from crane (9) to ISO corners (23) on shipping frame (24).



- Descend from top of module ISOPAK and remove ladder.

WARNING



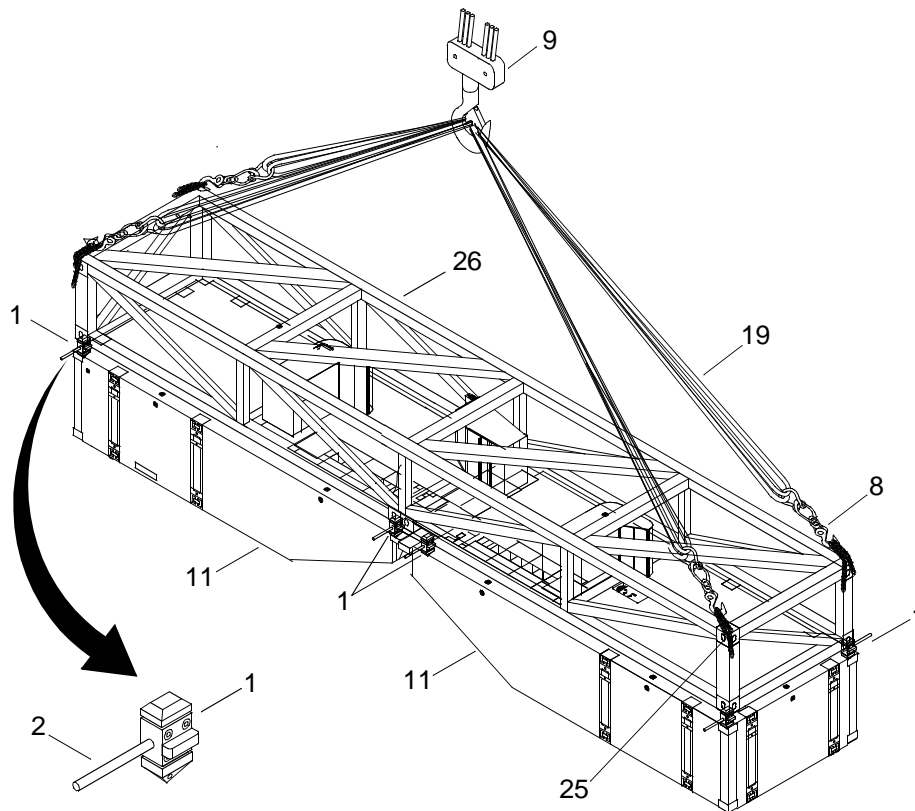
HEAVY PARTS

- Using crane and slings, remove shipping frame (22) from end rakes (11).
- Remove 36,000 lb adjustable chain slings (8) from ISO corners (23) on shipping frame (24).
- Remove 66,000 lb slings (19) from crane (9).
- Remove ISOPAK vertical connectors (1) from end rakes (11).

REMOVE PLENUMS SHIPPING FRAME FROM END RAKE MODULE ISOPAK

- Unlock eight ISOPAK vertical connectors (1) on corners of end rake (11) by rotating lever (2).
- Using ladder, climb on top of module ISOPAK.

- Attach two 66,000 lb slings (19) and four 36,000 lb adjustable chain slings (8) from crane (9) to ISO corners (25) on shipping frame (26).



- Descend from top of module ISOPAK and remove ladder.

WARNING

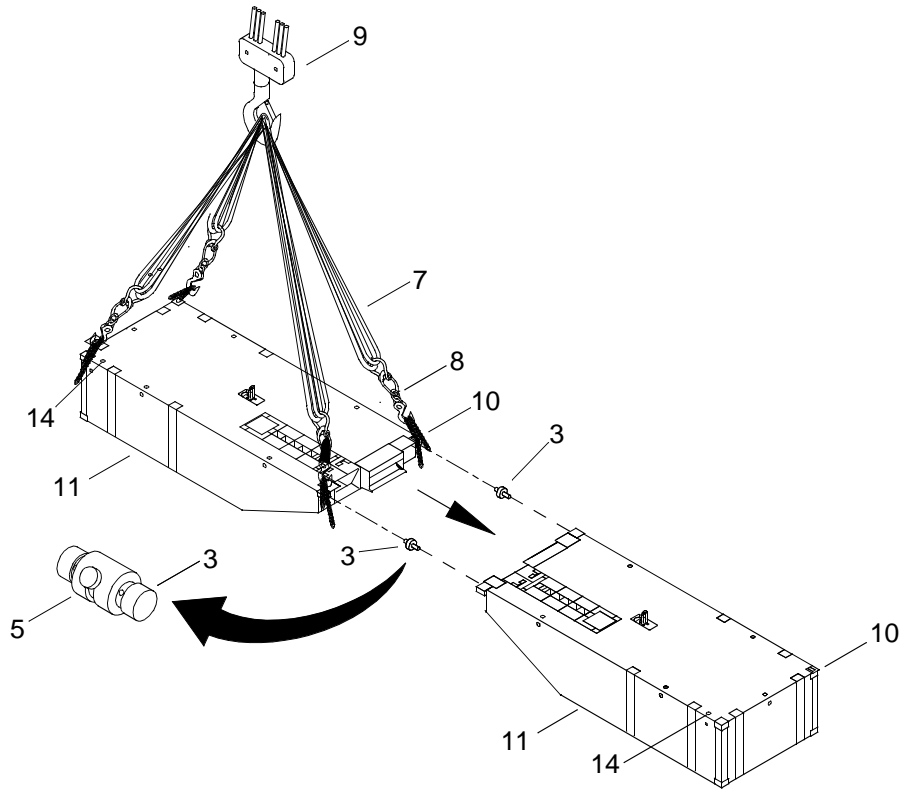


HEAVY PARTS

- Using crane and slings, remove shipping frame (24) from end rakes (11).
- Remove 36,000 lb adjustable chain slings (8) from ISO corners (23) on shipping frame (24).
- Remove 66,000 lb slings (19) from crane (9).
- Remove ISOPAK vertical connectors (1) from end rakes (11).

SEPARATE END RAKES

- Using ladder, climb on top of end rake modules (11).
- Unlock two ISOPAK horizontal twist locks (3) by rotating lever (5).

**NOTE**

Left and right modules are rigged and lifted in same manner.

3. Attach four 8,400 lb slings (7) and four 36,000 lb adjustable chain slings (8) from crane (9) to ISO corners (10) on end rake module (11).
4. Descend from top of module (11) and remove ladder.

WARNING**HEAVY PARTS**

5. Using slings (7 and 8) and crane (9), lift end rake module (11) into position for assembly.
6. Remove 8,400 lb slings (7) and 36,000 lb adjustable chain slings (8) from ISO corners (10) on end rake module (11).
7. Remove ISOPAK horizontal twist locks (3).

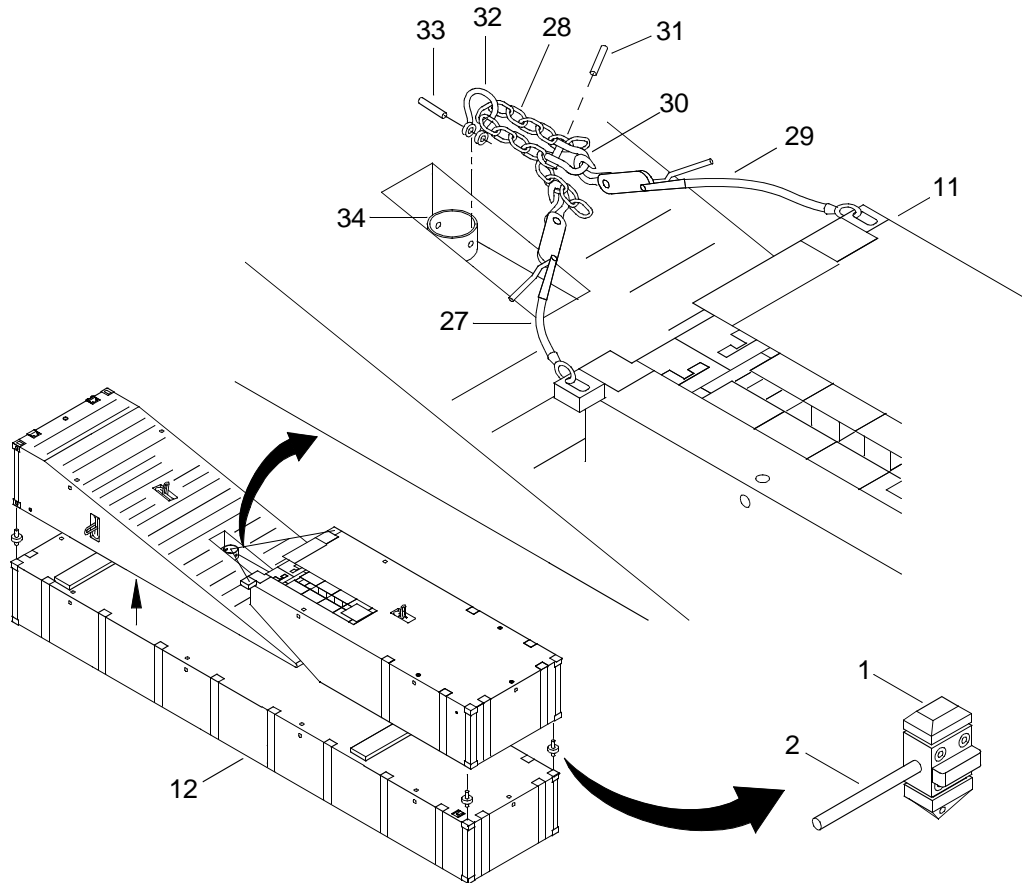
NOTE

Drain plug location may vary.

8. Inspect modules to ensure drain plugs (14) are installed in all end rake modules (11).

DISASSEMBLE CAUSEWAY FERRY BEACH END (CFBE) MODULE ISOPAK

1. Using ladder, climb on top of module ISOPAK.
2. Unlock four vertical connectors (1) by rotating levers (2).

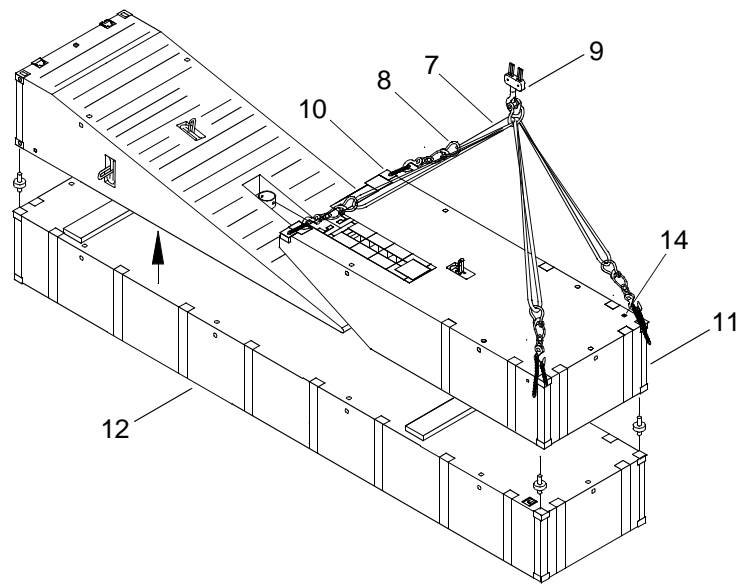


3. Remove tie down cable (27) from end rake (11) and chain (28).
4. Remove tie down cable (29) from end rake (11) and shackle (30).
5. Remove pin (31) from shackle (30) and remove shackle (30).
6. Remove chain (28) from shackle (32).
7. Remove pin (33) from shackle (32).
8. Remove shackle (32) from rhino horn fitting (34).

NOTE

Either a left, right or center end rake may be mounted on the center module with a CFBE.

9. Attach four 8,400 lb slings (7) and four 36,000 lb adjustable chain slings (8) from crane (9) to corners (10) on end rake module (11).



10. Descend from top of module ISOPAK and remove ladder.

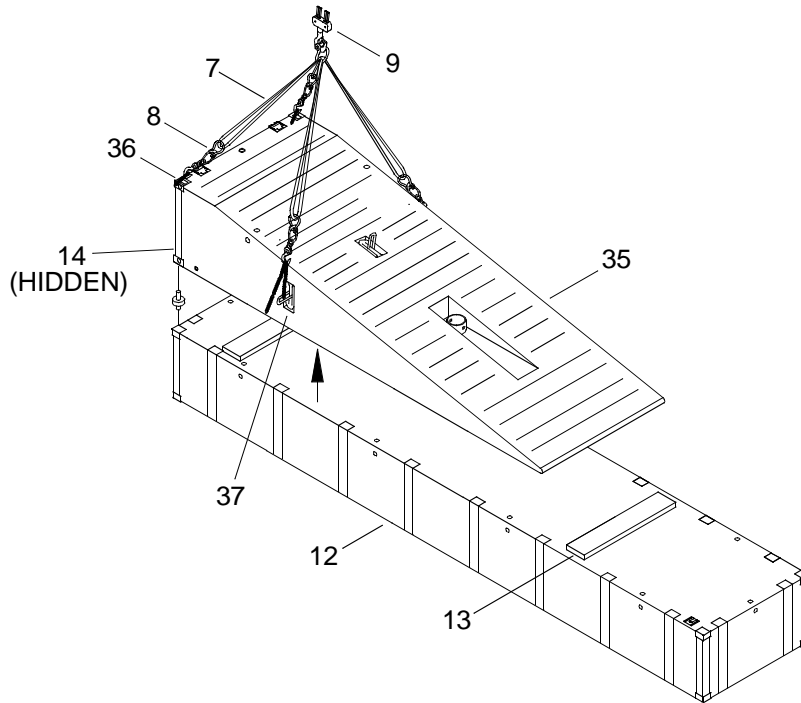
WARNING



HEAVY PARTS

11. Using slings (7 and 8) and crane (9), lift end rake module (11) from top of center module (12).
12. Remove 36,000 lb adjustable chain slings (8) from corners (10) on end rake module (11).
13. Remove 8,400 lb slings (7) from crane (9).
14. Verify drain plugs (14) on end rake modules (11) are installed.

15. Using ladder, climb on top of CFBE module (35).



16. Attach four 8,400 lb slings (7) and four 36,000 lb adjustable chain slings (8) from crane (9) to two corners (36) and two side padeyes (37) on CFBE module (35).

17. Descend from top of module and remove ladder.

WARNING



HEAVY PARTS

18. Using slings (7 and 8) and crane (9), lift CFBE module (33), from top of center module (12) and into position for assembly.

19. Remove 36,000 lb adjustable chain slings (8) from two corners (36) and two side padeyes (37) on CFBE module (35).

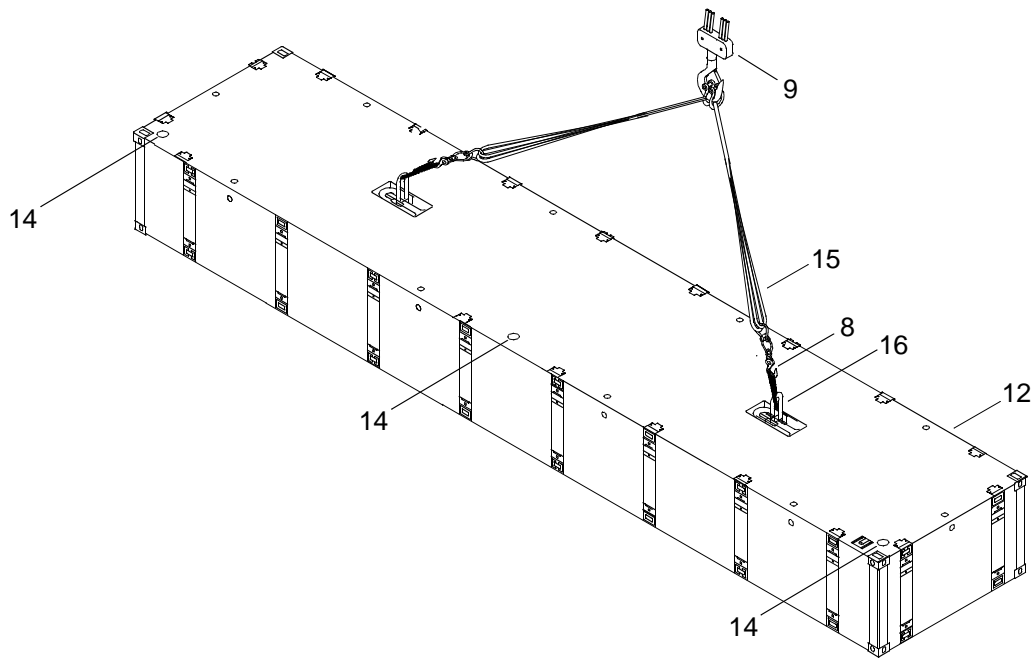
20. Remove 8,400 lb slings (7) from crane (9).

21. Remove dunnage (13) from top of center module (12).

22. Verify drain plug (14) on CFBE module (35) is installed.

23. Using ladder, climb on top of module ISOPAK.

24. Attach two 53,000 lb slings (15) and two 36,000 lb adjustable chain slings (8) from crane (9) to padeyes (16) on center module (12).



25. Descend from top of module and remove ladder.

WARNING



HEAVY PARTS

26. Using slings (8 and 15) and crane (9), lift center module (12) into position for assembly.
27. Remove 36,000 lb adjustable chain slings (8) from padeyes (16) on center module (12).
28. Remove 53,000 lb slings (15) from crane (9).
29. Verify drain plugs (14) are installed on center module (12).

END OF WORK PACKAGE

**OPERATOR MAINTENANCE
CAUSEWAY FERRY
MALE AND FEMALE GUILLOTINE CONNECTORS
OPERATION UNDER USUAL CONDITIONS**

INITIAL SETUP:**Tools**

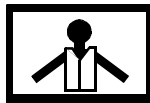
Tool Kit, General Mechanic's (Rail and Marine) (Item 76, WP 0105 00)
 Gloves, Men's and Women's (Leather Palm) (Item 31, WP 0105 00)
 Goggles, Sun, Wind and Dust (Safety) (Item 34, WP 0105 00)
 Life Preserver, Vest (Item 45, WP 0105 00)
 Helmet, Safety (Brown) (Item 40, WP 0105 00)
 Crowbar (Item 15, WP 0105 00)
 Hammer, Hand (10 lb Sledge) (Item 36, WP 0105 00)

Personnel Required

Seaman 88K

Equipment Condition

Module ISOPAK Disassembled. (WP 0007 00)

PREPARATION FOR USE - OPERATION OF MALE AND FEMALE GUILLOTINE CONNECTORS**WARNING**

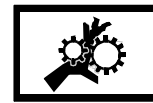
VEST



HELMET PROTECTION



HEAVY PARTS



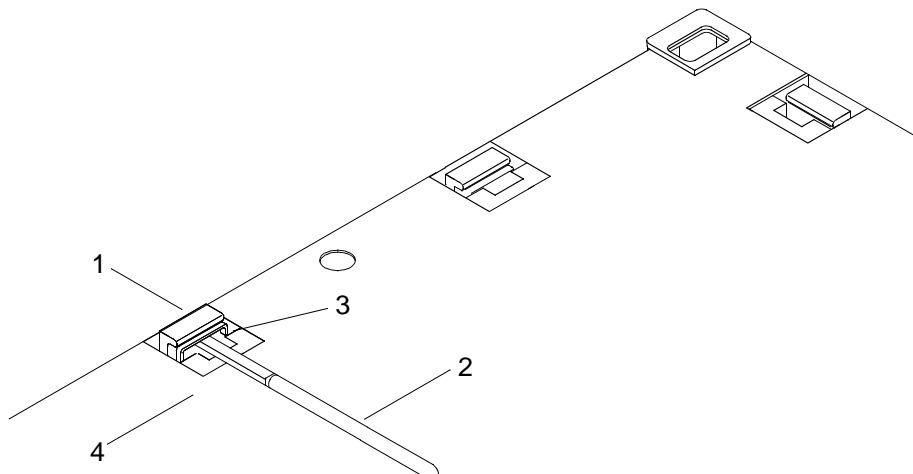
MOVING PARTS

All personnel must wear personal flotation device, hard hat, safety shoes, and gloves during CF operations and maintenance. Failure to observe these precautions could result in serious injury or death.

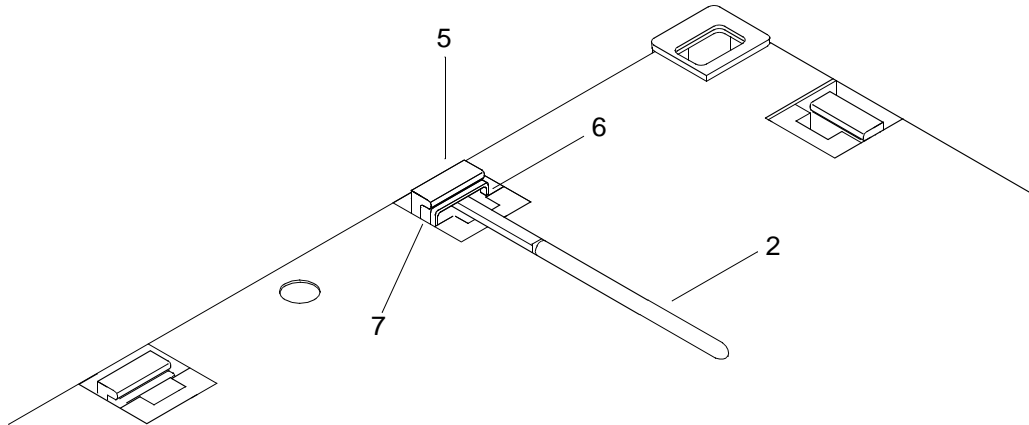
NOTE

The following procedure is typical for all module side and end connectors.

1. Raise the female guillotine bars (1).



- a. Insert crowbar (2) behind the spring bar (3) under the female guillotine bar (1).
 - b. Rotate the crowbar (2) downward to clear spring bar (3) from deck overhangs (4) and allow the female guillotine bar (1) to move upward.
 - c. Raise the female guillotine bar (1) approximately 6 in. until it stops.
2. Raise the male guillotine bars (5).



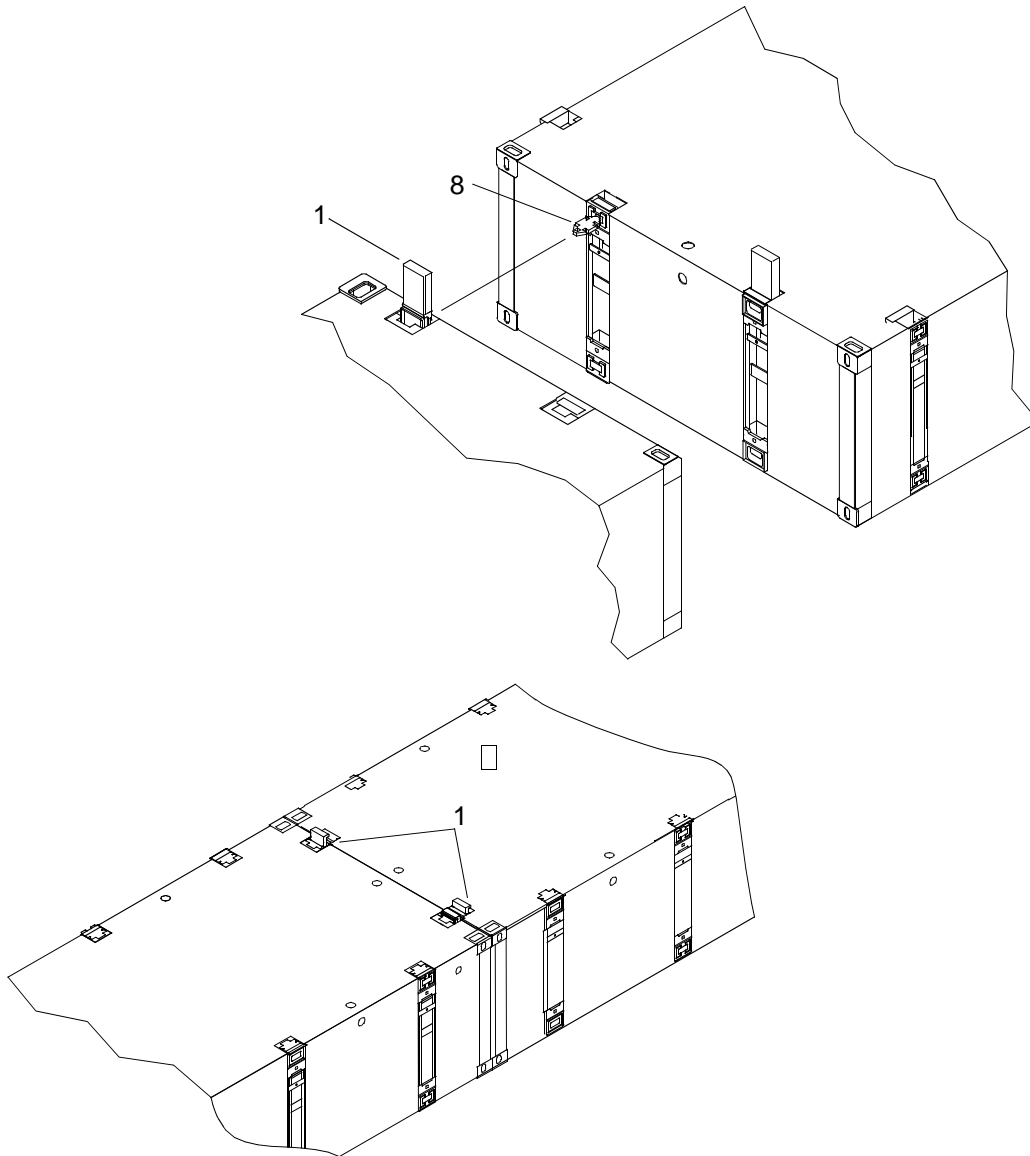
- a. Insert crowbar (2) behind the spring bar (6) under the male guillotine bar (5).
- b. Rotate the crowbar (2) downward to clear spring bar (6) from deck overhangs (7) and allow male guillotine bar (5) to move upward.

NOTE

Personnel should hear two clicks as both pins extend or, if the module is in the water, personnel should see the first pin extend and continue to pull up until one can hear or feel the second lower pin extend.

- c. Raise the male guillotine bar (5) approximately 6 in. until it stops, allowing male connector pins to fully extend.
- d. Remove the crowbar (2).
- e. Drive the guillotine bar (5) back into stowed position using a sledgehammer to secure the male connector pins (8) in the fully extended position.

3. Position the modules to be connected so that the male connector pins (9) and female connectors (1) are aligned.



4. Using a sledgehammer, drive each female guillotine (1) connector down.

END OF WORK PACKAGE

**OPERATOR MAINTENANCE
CAUSEWAY FERRY
D-RING/CLOVERLEAF AND DECK CLEAT FITTINGS
OPERATION UNDER USUAL CONDITIONS**

INITIAL SETUP:**Tools**

Tool Kit, General Mechanic's (Rail and Marine) (Item 76, WP 0105 00)
 Gloves, Men's and Women's (Leather Palm) (Item 31, WP 0105 00)
 Goggles, Sun, Wind and Dust (Safety) (Item 34, WP 0105 00)
 Life Preserver, Vest (Item 45, WP 0105 00)
 Helmet, Safety (Brown) (Item 40, WP 0105 00)
 Crowbar (Item 15, WP 0105 00)
 Hammer, Hand (10 lb Sledge) (Item 36, WP 0105 00)

Personnel Required

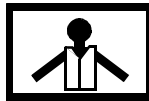
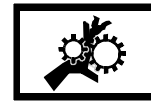
Seaman 88K

Equipment Condition

Module ISOPAK Disassembled. (WP 0007 00)
 Operation Of Male And Female Guillotine Connectors. (WP 0008 00)

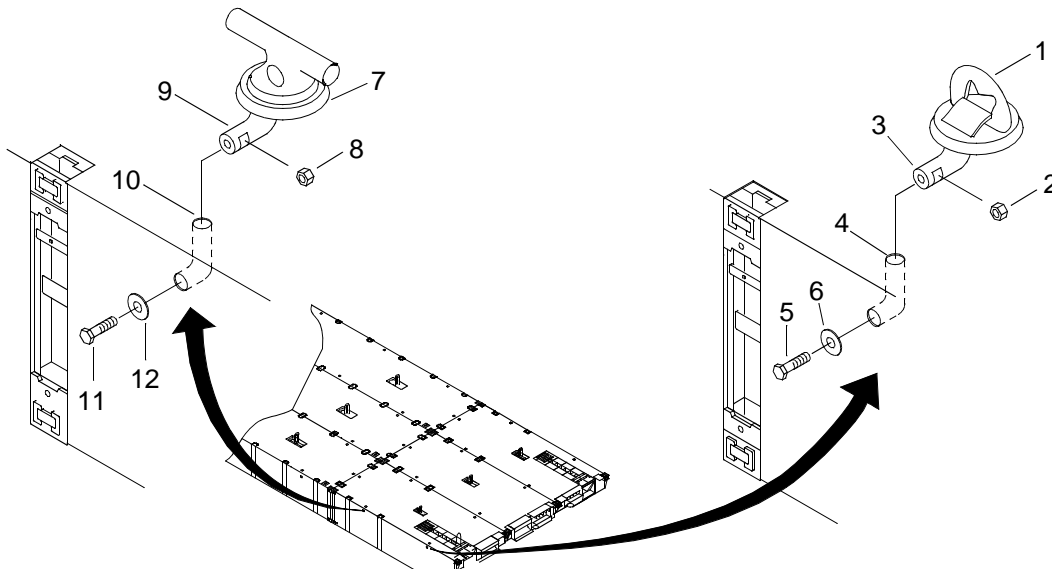
PREPARATION FOR USE - INSTALL D-RING/CLOVERLEAF AND DECK CLEAT FITTINGS

WARNING

**VEST****HELMET PROTECTION****HEAVY PARTS****MOVING PARTS**

All personnel must wear personal flotation device, hard hat, safety shoes, and gloves during CF operations and maintenance. Failure to observe these precautions could result in serious injury or death.

1. Install D-ring/Cloverleaf fittings (1) on modules as follows:



- a. Place nut (2) in slot in the tailpiece (3) of the D-ring/Cloverleaf fitting (1).
- b. Insert D-ring/Cloverleaf fitting (1) into module turn tube (4).

WARNING

Beware of other craft or objects coming alongside while working outboard installing the bolt and washer. Serious injury may result if body parts are crushed between module and other craft or objects.

Use extreme caution while working outboard and lifting heavy objects as the possibility of falling overboard exists, which could cause serious injury or death.

- c. Insert bolt (5) through keeper plate (6) and thread it into nut (2) in tailpiece (3).
 - d. Tighten bolt (5).
2. Install deck cleat fitting (7) on modules as follows:
- a. Place nut (8) in slot in the tailpiece (9) of the deck cleat fitting (7).
 - b. Insert deck cleat fitting (7) into module turn tube (10).

WARNING

Beware of other craft or objects coming alongside while working outboard installing the bolt and washer. Serious injury may result if body parts are crushed between module and other craft or objects.

Use extreme caution while working outboard and lifting heavy objects as the possibility of falling overboard exists, which could cause serious injury or death.

- c. Insert bolt (11) through keeper plate (12) and thread it into nut (8) in tailpiece (9).
- d. Tighten bolt (11).

END OF WORK PACKAGE

**OPERATOR MAINTENANCE
CAUSEWAY FERRY
MODULE STRINGS
OPERATION UNDER USUAL CONDITIONS**

INITIAL SETUP:**Tools**

Tool Kit, General Mechanic's (Rail and Marine) (Item 76, WP 0105 00)
 Gloves, Men's and Women's (Leather Palm) (Item 31, WP 0105 00)
 Goggles, Sun, Wind and Dust (Safety) (Item 34, WP 0105 00)
 Life Preserver, Vest (Item 45, WP 0105 00)
 Helmet, Safety (Brown) (Item 40, WP 0105 00)
 Sling, Lifting, 53,000 lb (Brown) (Item 67, WP 0105 00)
 Qty 2
 Sling, Lifting, 8,400 lb (Yellow) (Item 72, WP 0105 00)
 Qty 4
 Sling, Lifting, 36,000 lb Adjustable Chain (Item 66, WP 0105 00)
 Qty 4

Personnel Required

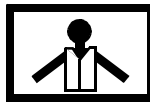
Seaman 88K (2)

Equipment Condition

Module ISOPAK Disassembled. (WP 0007 00)

PREPARATION FOR USE - ASSEMBLY OF MODULE STRINGS

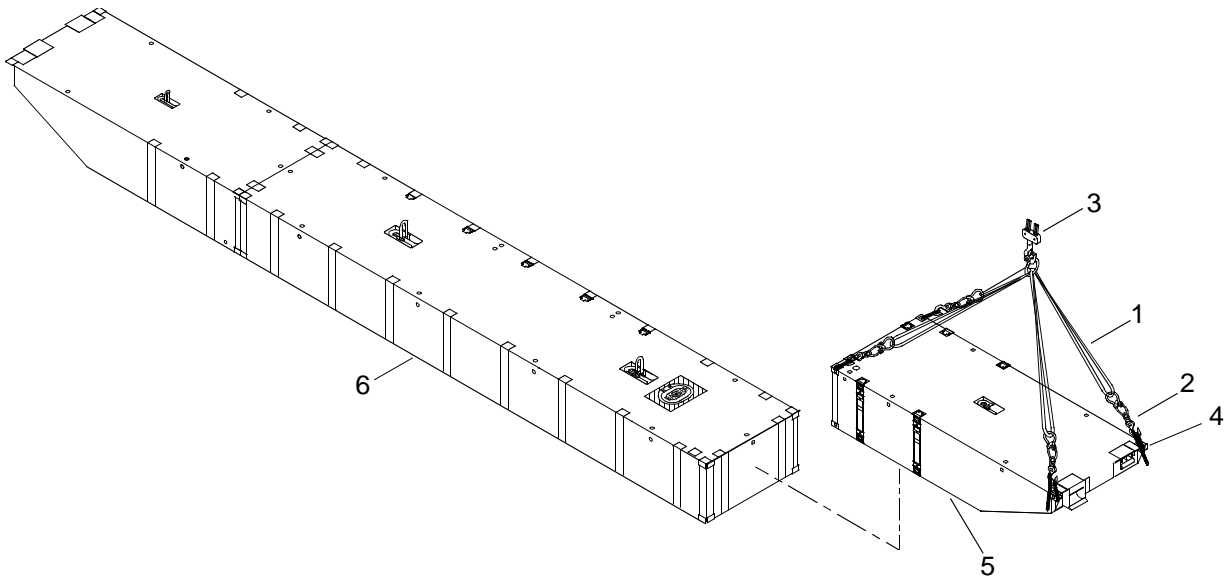
WARNING

**VEST****HELMET PROTECTION****HEAVY PARTS****MOVING PARTS**

All personnel must wear personal flotation device, hard hat, safety shoes and gloves during CF operations and maintenance. Failure to observe these precautions could result in serious injury or death.

ASSEMBLY OF MODULE STRINGS ON DECK OF SEALIFT VESSEL

1. Attach four 8,400 lb slings (1) and four 36,000 lb adjustable chain slings (2) from crane (3) to ISO corners (4) on end rake module (5).



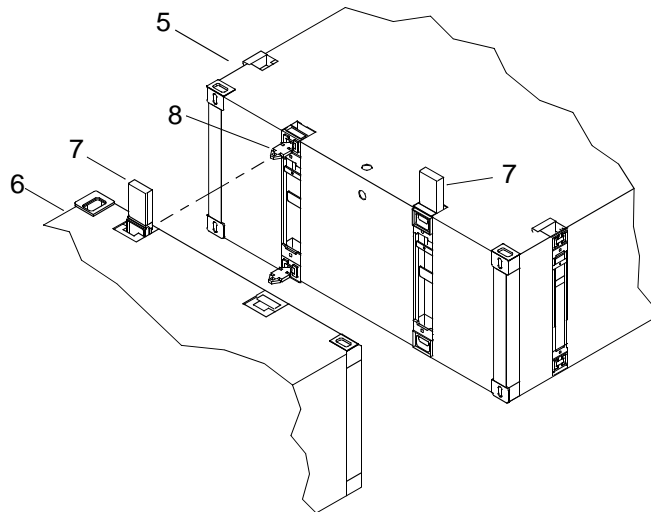
WARNING

**HEAVY PARTS**

- Using slings (1 and 2) and crane (3), position end rake module (5) at end of center module (6) so that female connectors (7) and male connectors (8) of end rake (5) and center module (6) align.

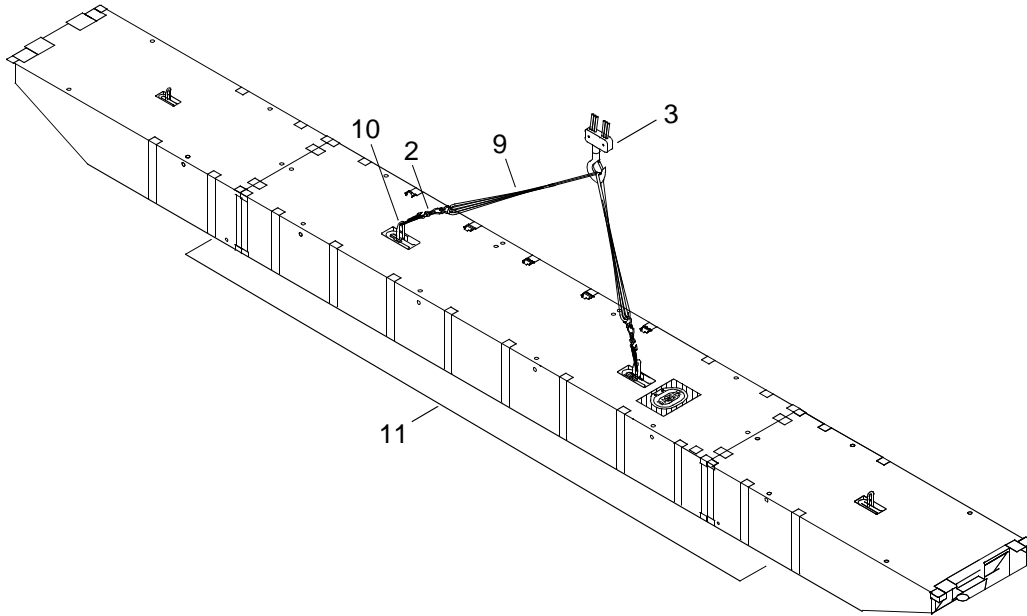
NOTE

This procedure is typical for attaching center rake or end rake modules to center modules.



- Operate male and female guillotine connectors. (WP 0008 00)
- Remove 36,000 lb adjustable chain slings (2) from ISO corners (4) on end rake module (5).

5. Remove 8,400 lb slings (1) from crane (3).
6. Attach two 53,000 lb slings (9) and two 36,000 lb adjustable chain slings (2) from crane (3) to padeye shackles (10) on module string (11).



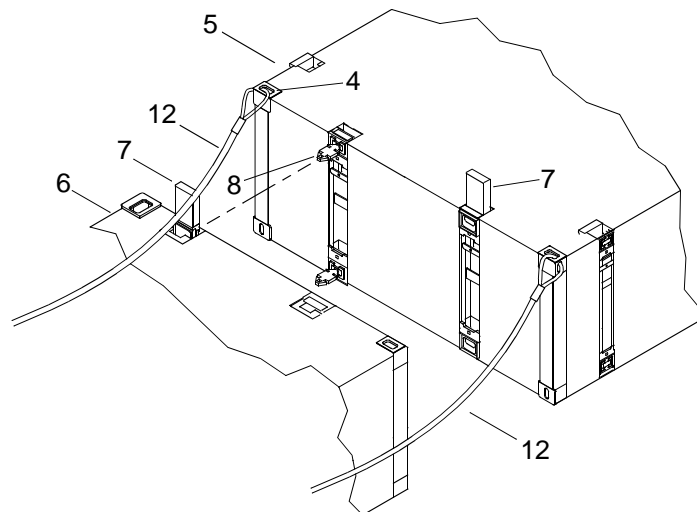
7. Using slings (2 and 9) and crane (3), position module string (11) for propulsion module assembly.
8. Remove 36,000 lb adjustable chain slings (2) from padeye (10) on module string (11).
9. Remove 53,000 lb chain slings (2) from crane (3).

ASSEMBLY OF MODULE STRINGS IN WATER

NOTE

This procedure is typical for attaching left or right end rakes to center modules.

1. Attach tag lines (12) to ISO corner fittings (4) on end rake module (5).



WARNING

Place hands on top or on the outside of ropes/lines so that in an emergency the lines can be released quickly to preclude being pulled into the equipment. Failure to observe these precautions could result in serious injury or death.

2. Using tag lines (12), position end rake module (5) so that female connectors (7) and male connectors (8) align with female connectors (7) and male connectors (8) on center module (6).
3. Operate male and female guillotine connectors. (WP 0008 00)
4. Remove tag lines (12).

END OF WORK PACKAGE

**OPERATOR MAINTENANCE
CAUSEWAY FERRY
INTERMEDIATE SECTION
OPERATION UNDER USUAL CONDITIONS**

INITIAL SETUP:**Tools**

Tool Kit, General Mechanic's (Rail and Marine) (Item 76, WP 0105 00)
 Gloves, Men's and Women's (Leather Palm) (Item 31, WP 0105 00)
 Goggles, Sun, Wind and Dust (Safety) (Item 34, WP 0105 00)
 Life Preserver, Vest (Item 45, WP 0105 00)
 Helmet, Safety (Brown) (Item 40, WP 0105 00)
 Crowbar (Item 15, WP 0105 00)
 Sling, Lifting, 53,000 lb (Brown) (Item 67, WP 0105 00)
 Qty 4
 Sling, Lifting, 36,000 lb Adjustable Chain (Item 66, WP 0105 00)
 Qty 4

Personnel Required

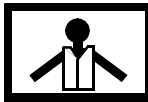
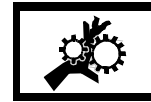
Seaman 88K (2)

Equipment Condition

Module ISOPAK Disassembled. (WP 0007 00)
 Operation Of Male And Female Guillotine Connectors. (WP 0008 00)
 D-Ring/Cloverleaf Fittings And Deck Cleat Fittings Installed. (WP 0009 00)
 Module String Assembled. (WP 0010 00)

PREPARATION FOR USE - ASSEMBLY OF INTERMEDIATE SECTION

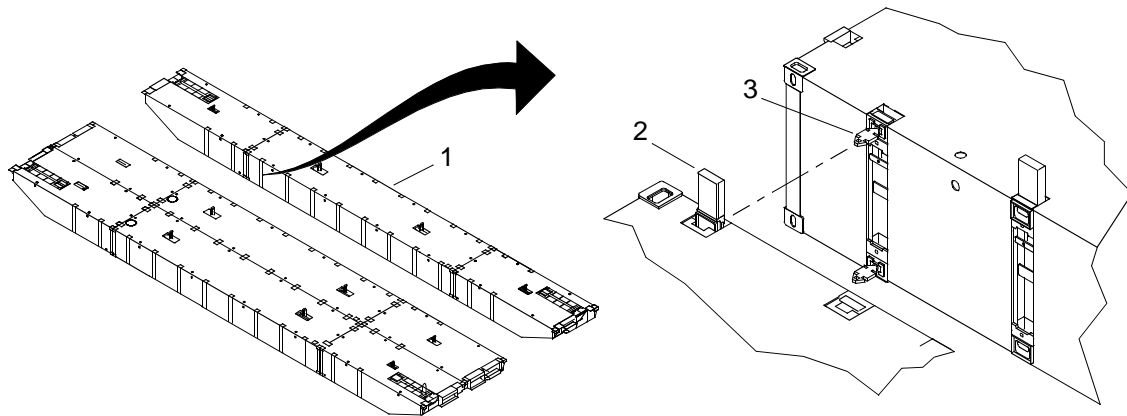
WARNING

**VEST****HELMET PROTECTION****HEAVY PARTS****MOVING PARTS**

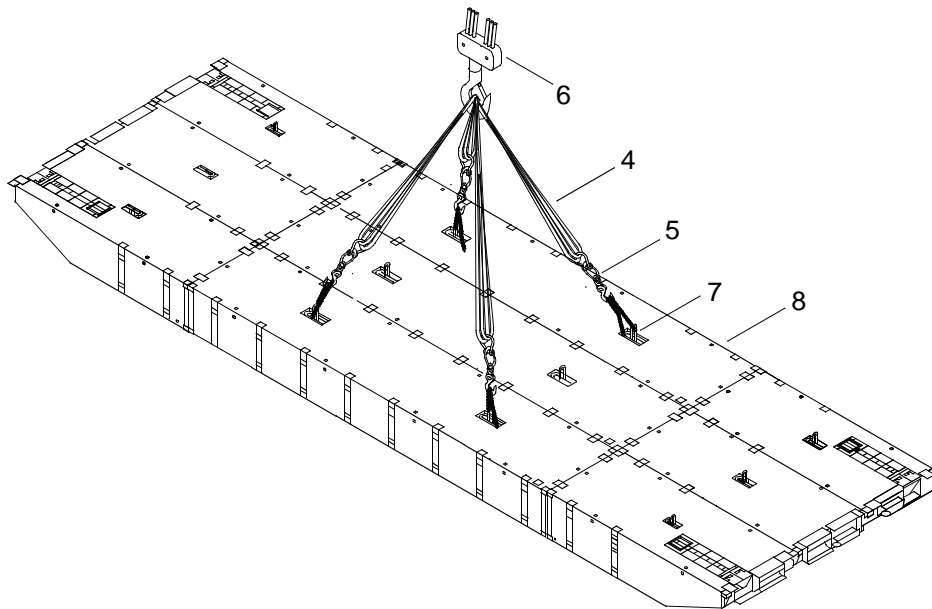
All personnel must wear personal flotation device, hard hat, safety shoes and gloves during CF operations and maintenance. Failure to observe these precautions could result in serious injury or death.

ASSEMBLY OF INTERMEDIATE SECTION ON SEALIFT VESSEL

1. Position module string (1) so that female connectors (2) align with male connectors (3) on the other module strings (1).



2. Operate male and female connectors. (WP 0008 00)
3. Attach four 53,000 lb slings (4) and four 36,000 lb adjustable chain slings (5) from crane (6) to padeye shackles (7) on intermediate section (8).



WARNING



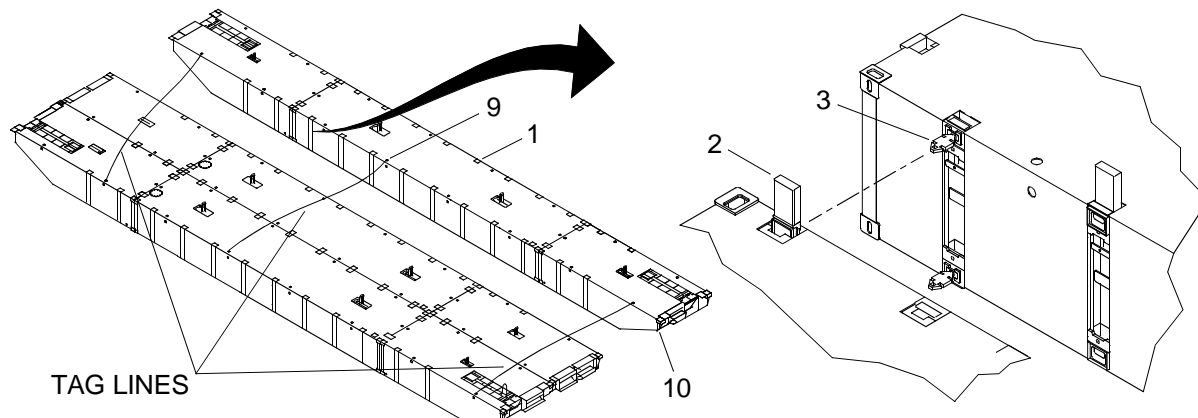
HEAVY PARTS

4. Using slings (4 and 5) and crane (6), lift intermediate section (8) and place in water.
5. Remove 36,000 lb adjustable chain slings (5) from padeye shackles (7) on intermediate section (8).
6. Remove 53,000 lb slings (4) from 36,000 lb adjustable chain slings (5) and crane (6).

ASSEMBLY OF INTERMEDIATE SECTION IN WATER**NOTE**

This procedure is typical for attaching module strings together in water.

1. Attach tag lines to turn tubes (9) and ISO corner fittings (10).

**WARNING**

Place hands on top or on the outside of ropes/lines so that in an emergency the lines can be released quickly to preclude being pulled into the equipment. Failure to observe these precautions could result in serious injury or death.

2. Using tag lines, maneuver module strings (1) so that female connectors (2) align with male connectors (3).
3. Operate male and female guillotine connectors. (WP 0008 00)
4. Remove tag lines.

END OF WORK PACKAGE

**OPERATOR MAINTENANCE
CAUSEWAY FERRY
BEACH END SECTION
OPERATION UNDER USUAL CONDITIONS**

INITIAL SETUP:**Tools**

Tool Kit, General Mechanic's (Rail and Marine) (Item 76, WP 0105 00)
 Gloves, Men's and Women's (Leather Palm) (Item 31, WP 0105 00)
 Goggles, Sun, Wind and Dust (Safety) (Item 34, WP 0105 00)
 Life Preserver, Vest (Item 45, WP 0105 00)
 Helmet, Safety (Brown) (Item 40, WP 0105 00)
 Crowbar (Item 15, WP 0105 00)
 Sling, Lifting, 53,000 lb (Brown) (Item 67, WP 0105 00)
 Qty 4
 Sling, Lifting, 36,000 lb Adjustable Chain (Item 66, WP 0105 00)
 Qty 4

Personnel Required

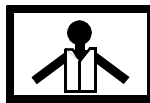
Seaman 88K (2)

Equipment Condition

Module ISOPAK Disassembled. (WP 0007 00)
 D-Ring/Cloverleaf Fittings And Deck Cleat Fittings Installed. (WP 0009 00)
 Module String Assembled. (WP 0010 00)
 Intermediate Section Assembled. (WP 0011 00)

**PREPARATION FOR USE - ASSEMBLE CAUSEWAY FERRY BEACH END
(CFBE) SECTION**

WARNING



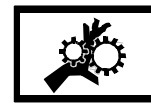
VEST



HELMET PROTECTION



HEAVY PARTS

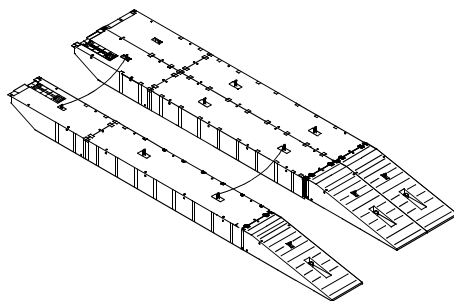


MOVING PARTS

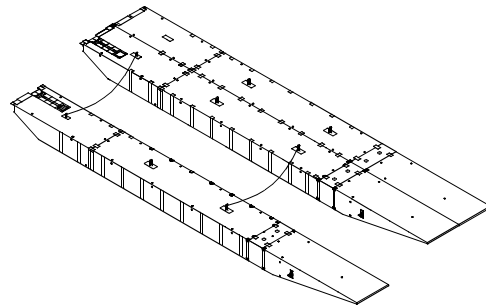
All personnel must wear personal flotation device, hard hat, safety shoes and gloves during CF operations and maintenance. Failure to observe these precautions could result in serious injury or death.

**ASSEMBLE CAUSEWAY FERRY BEACH END SECTION ON DECK OF
SEALIFT VESSEL**

1. Use appropriate configuration for application.

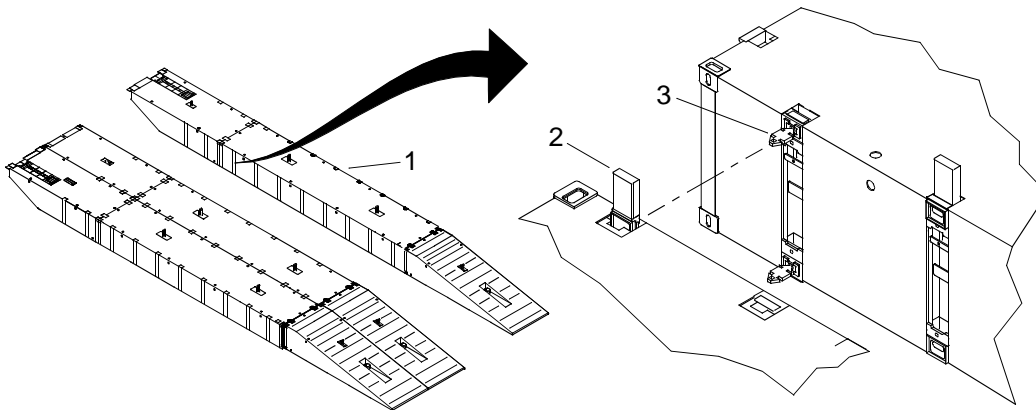


CAUSEWAY FERRY
BEACH END SECTION

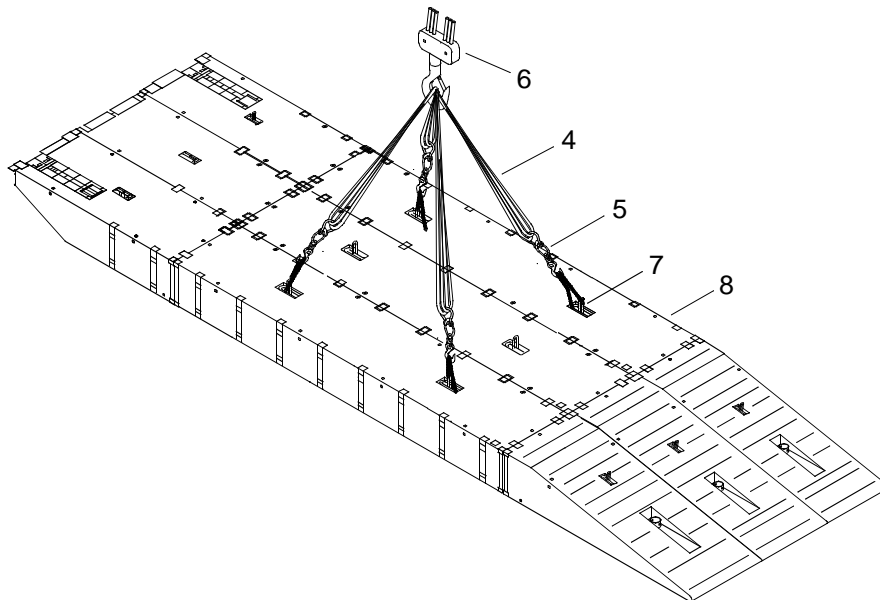


CAUSEWAY FERRY BEACH END SECTION ALTERNATE
CONFIGURATION (USING P3 ADAPTER)

2. Position module string (1) so that female connectors (2) align with male connectors (3) on the other module strings (1).



3. Operate the male and female connectors. (WP 0008 00)
4. Attach four 53,000 lb slings (4) and four 36,000 lb adjustable chain slings (5) from crane (6) to padeye shackles (7) on causeway ferry beach end section (8).



 WARNING

**HEAVY PARTS**

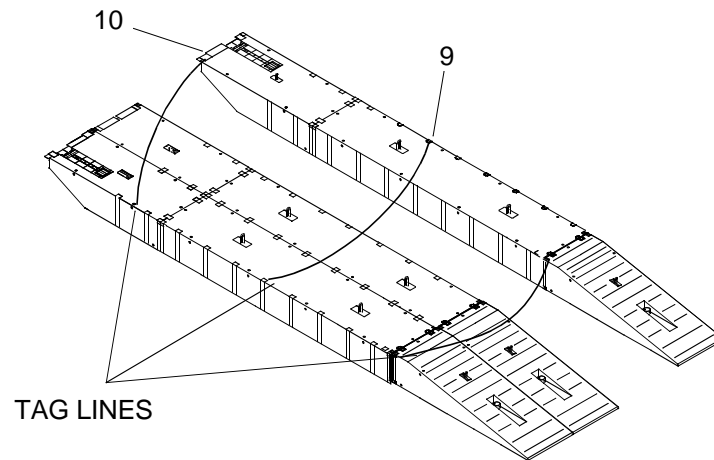
5. Using slings (4 and 5) and crane (6), lift causeway ferry beach end section (8) and place in water.
6. Remove 36,000 lb adjustable chain slings (5) from padeye shackles (7) on causeway ferry beach end section (8).
7. Remove 53,000 lb slings (4) from 36,000 lb adjustable chain slings (5) and crane (6).

ASSEMBLY OF CAUSEWAY FERRY BEACH END SECTION IN WATER

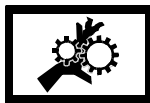
NOTE

This procedure is typical for attaching module strings in water.

1. Attach tag lines to turn tubes (9) and ISO corner fittings (10).



 WARNING

**MOVING PARTS**

Place hands on top or on the outside of ropes/lines so that in an emergency the lines can be released quickly to preclude being pulled into the equipment. Failure to observe these precautions could result in serious injury or death.

2. Using tag lines, maneuver module strings (1) so that female connectors (2) align with male connectors (3).
3. Operate male and female guillotine connectors. (WP 0008 00)
4. Remove tag lines.

END OF WORK PACKAGE

**OPERATOR MAINTENANCE
CAUSEWAY FERRY
POWERED SECTION
OPERATION UNDER USUAL CONDITIONS**

INITIAL SETUP:**Tools**

Tool Kit, General Mechanic's (Rail and Marine) (Item 76, WP 0105 00)
 Gloves, Men's and Women's (Leather Palm) (Item 31, WP 0105 00)
 Goggles, Sun, Wind and Dust (Safety) (Item 34, WP 0105 00)
 Life Preserver, Vest (Item 45, WP 0105 00)
 Helmet, Safety (Brown) (Item 40, WP 0105 00)
 Sling, Lifting, 66,000 lb (Olive) (Item 71, WP 0105 00)
 Qty 4
 40-Ton 1-3/4 in. Alloy Anchor Shackle (Item 4, WP 0105 00)
 Qty 4

Personnel Required

Seaman 88K (2)

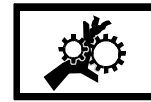
Equipment Condition

Module ISOPAK Disassembled. (WP 0007 00)
 Operation Of Male And Female Guillotine Connectors. (WP 0008 00)
 D-Ring/Cloverleaf Fittings And Deck Cleat Fittings Installed. (WP 0009 00)
 Module String Assembled. (WP 0010 00)

**PREPARATION FOR USE - ASSEMBLY OF CAUSEWAY FERRY POWERED SECTION
ON DECK OF SEALIFT VESSEL**

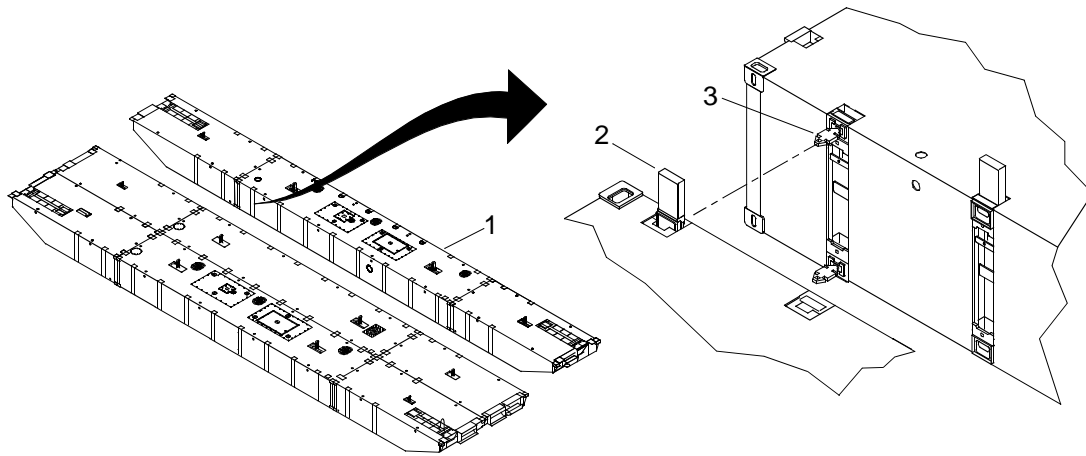
ASSEMBLE POWERED SECTION

WARNING

**VEST****HELMET PROTECTION****HEAVY PARTS****MOVING PARTS**

All personnel must wear personal flotation device, hard hat, safety shoes and gloves during CF operations and maintenance. Failure to observe these precautions could result in serious injury or death.

1. Position module string (1) so that female connectors (2) align with male connectors (3) on other module strings (1).



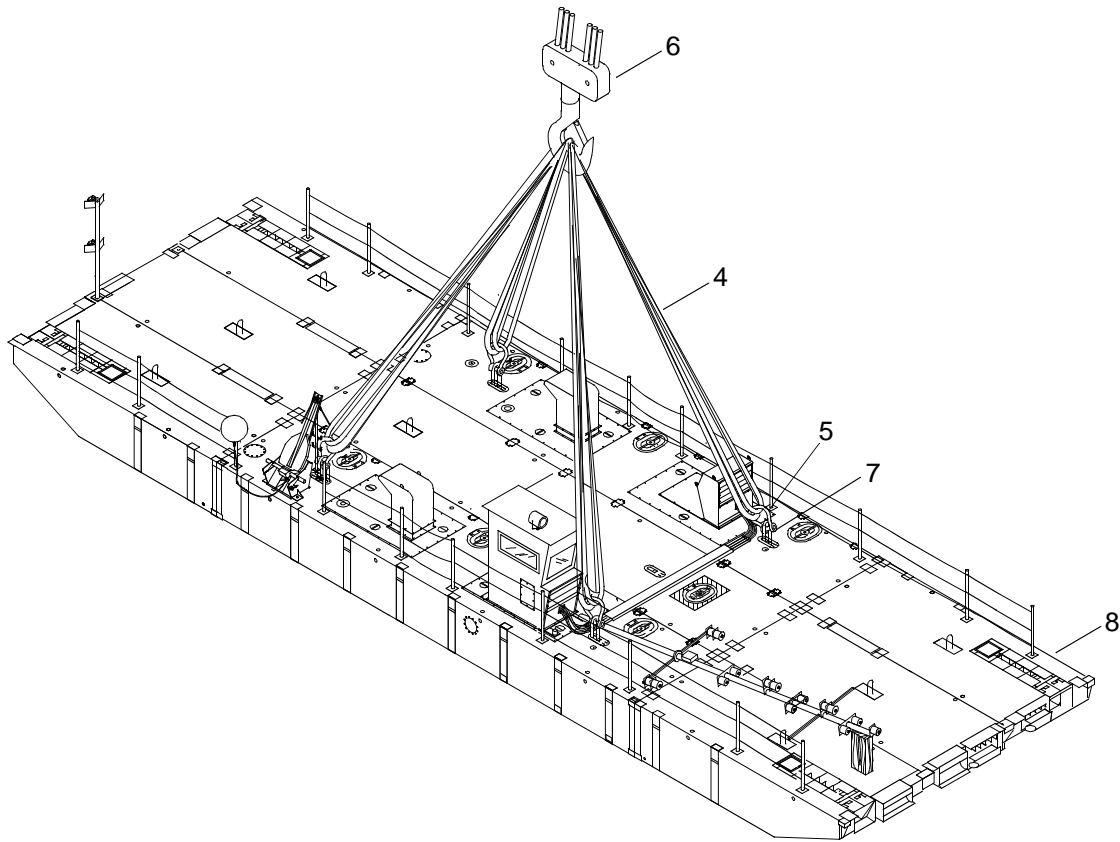
2. Operate male and female connectors. (WP 0008 00)
3. Install causeway ferry stabilizers. (WP 0013 20)

NOTE

Do not raise main mast until CF powered section is placed in water.

4. Install above deck equipment. (WP 0014 00)
5. Install anchorboard assembly. (WP 0015 00)
6. Install stub navigation mast. (WP 0016 00)
7. Install fenders. (WP 0017 00)
8. Install safety equipment. (WP 0018 00)

9. Attach four 66,000 lb slings (4) and four 40-ton shackles (5) from crane (6) to padeye shackles (7) on powered section (8).



WARNING



HEAVY PARTS

10. Using slings (4), shackles (5) and crane (6), lift powered section (8) and place in water.
11. Remove 40-ton shackles (5) from padeye shackles (7) on powered section (8).
12. Remove 66,000 lb slings (4) and 40-ton shackles (5) from crane (6).
13. Raise main mast assembly. (WP 0014 00)

END OF WORK PACKAGE

**OPERATOR MAINTENANCE
CAUSEWAY FERRY
POWERED SECTION
OPERATION UNDER USUAL CONDITIONS**

INITIAL SETUP:

Tools

- Tool Kit, General Mechanic's (Rail and Marine) (Item 76, WP 0105 00)
- Gloves, Men's and Women's (Leather Palm) (Item 31, WP 0105 00)
- Goggles, Sun, Wind and Dust (Safety) (Item 34, WP 0105 00)
- Life Preserver, Vest (Item 45, WP 0105 00)
- Helmet, Safety (Brown) (Item 40, WP 0105 00)

Personnel Required

- Seaman 88K (2)

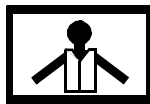
Equipment Condition

- Module ISOPAK Disassembled. (WP 0007 00)
- Operation Of Male And Female Guillotine Connectors. (WP 0008 00)
- D-Ring/Cloverleaf Fittings And Deck Cleat Fittings Installed. (WP 0009 00)
- Module String Assembled. (WP 0010 00)

**PREPARATION FOR USE - ASSEMBLY OF CAUSEWAY FERRY POWERED SECTION
IN WATER**

ASSEMBLE POWERED SECTION

WARNING



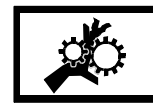
VEST



HELMET PROTECTION



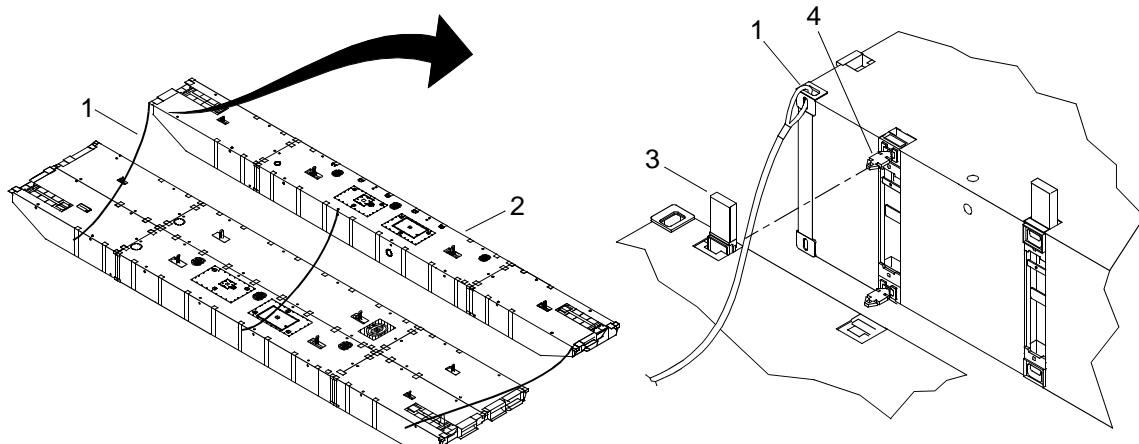
HEAVY PARTS



MOVING PARTS

All personnel must wear personal flotation device, hard hat, safety shoes and gloves during CF operations and maintenance. Failure to observe these precautions could result in serious injury or death.

1. Attach tag lines to ISO corner fittings (1).



2. Level module (2).
3. Position module string (2) so that female connectors (3) align with male connectors (4) on other module strings (2).
4. Operate male and female connectors. (WP 0008 00)
5. Install causeway ferry stabilizers. (WP 0013 20)
6. Install above deck equipment. (WP 0014 00)
7. Install anchorboard assembly. (WP 0015 00)
8. Install stub navigation mast. (WP 0016 00)
9. Install fenders. (WP 0017 00)
10. Install safety equipment. (WP 0018 00)

END OF WORK PACKAGE

**OPERATOR MAINTENANCE
CAUSEWAY FERRY
STABILIZERS
OPERATION UNDER USUAL CONDITIONS**

INITIAL SETUP:**Tools**

Tool Kit, General Mechanic's (Rail and Marine) (Item 76, WP 0105 00)
 Gloves, Men's and Women's (Leather Palm) (Item 31, WP 0105 00)
 Goggles, Sun, Wind and Dust (Safety) (Item 34, WP 0105 00)
 Life Preserver, Vest (Item 45, WP 0105 00)
 Helmet, Safety (Brown) (Item 40, WP 0105 00)
 2 Ton ½ in. Anchor Shackle (Item 1, WP 0105 00)
 Sling, Lifting, 5,300 lbs (Green) (Item 68, WP 0105 00)

Personnel Required

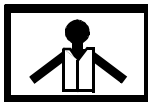
Seaman 88K

Equipment Condition

Module ISOPAK Disassembled. (WP 0007 00)
 Operation Of Male And Female Guillotine Connectors. (WP 0008 00)
 D-Ring/Cloverleaf Fittings And Deck Cleat Fittings Installed. (WP 0009 00)
 Module String Assembled. (WP 0010 00)
 Causeway Ferry Powered Section Assembled. (WP 0013 00, WP 0013 10)

PREPARATION FOR USE - INSTALL STABILIZERS

WARNING



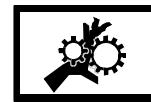
VEST



HELMET PROTECTION



HEAVY PARTS



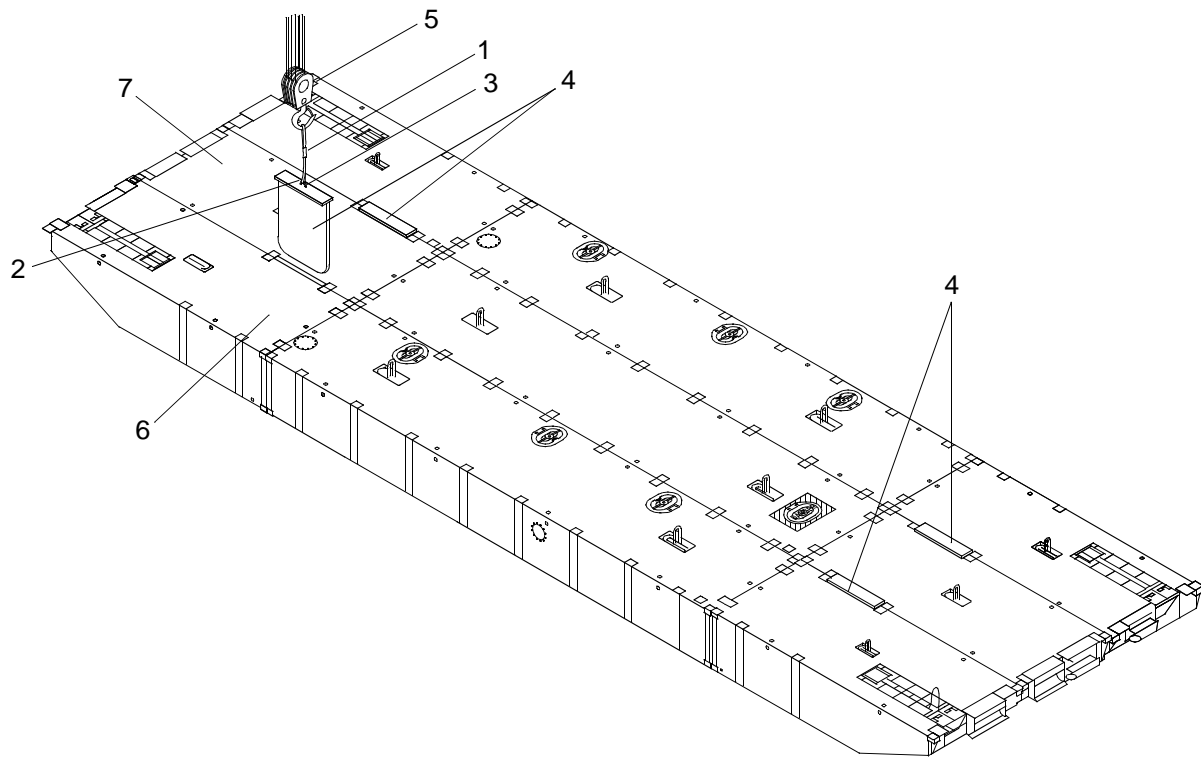
MOVING PARTS

All personnel must wear personal flotation device, hard hat, safety shoes and gloves during CF operations and maintenance. Failure to observe these precautions could result in serious injury or death.

NOTE

This task is typical for installation of stabilizers (skegs).

1. Attach sling (1) and shackle (2) to lifting eye (3) of stabilizer (4).



WARNING

**HEAVY PARTS**

2. Using crane (5), sling (1) and shackle (2), install stabilizer (4) into space between outboard end rake (6) and center end rake (7).
3. Remove sling (1) and shackle (2) from lifting eye (3) of stabilizer (4).

END OF WORK PACKAGE

**OPERATOR MAINTENANCE
CAUSEWAY FERRY
ABOVE DECK EQUIPMENT
OPERATION UNDER USUAL CONDITIONS**

INITIAL SETUP:**Tools**

Tool Kit, General Mechanic's (Rail and Marine) (Item 76, WP 0105 00)
Gloves, Men's and Women's (Leather Palm) (Item 31, WP 0105 00)
Goggles, Sun, Wind and Dust (Safety) (Item 34, WP 0105 00)
Life Preserver, Vest (Item 45, WP 0105 00)
Helmet, Safety (Brown) (Item 40, WP 0105 00)
Gloves, Chemical (Item 29, WP 0105 00)
Goggles, Industrial (Chipping, Chemical) (Item 32, WP 0105 00)
Sling, 5,300 lb (Green) (Item 69, WP 0105 00)
Qty 2
4 ¾ Ton ¾ in. Shackle (Item 5, WP 0105 00)
Qty 2

Materials/Parts

Adhesive (Item 1, WP 0106 00)
Shoring Block (Item 21, WP 0106 00)

Personnel Required

Seaman 88K (2)

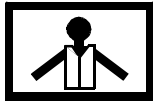
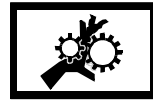
Equipment Condition

Module ISOPAK Disassembled. (WP 0007 00)
Operation Of Male And Female Guillotine Connectors. (WP 0008 00)
D-Ring/Cloverleaf And Deck Cleat Fittings Installed. (WP 0009 00)
Module String Assembled. (WP 0010 00)
Causeway Ferry Powered Section Assembled. (WP 0013 00, WP 0013 10)

**PREPARATION FOR USE - INSTALLATION OF CAUSEWAY FERRY ABOVE DECK
EQUIPMENT**

INSTALL OPERATORS CAB

WARNING

**VEST****HELMET PROTECTION****HEAVY PARTS****MOVING PARTS****VAPOR**

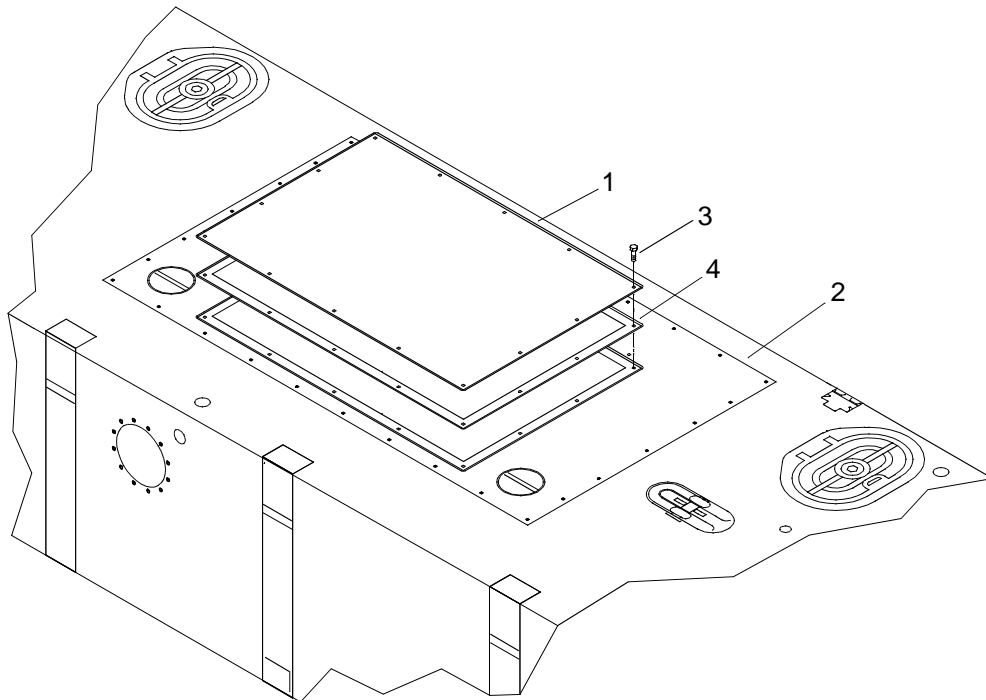
All personnel must wear personal flotation device, hard hat, safety shoes and gloves during CF operations and maintenance. Failure to observe these precautions could result in serious injury or death.

Attempting to assemble Warping Tug in higher sea conditions than Sea State 0 could cause injury or possible death to personnel and/or damage the equipment.

NOTE

The operators cab is normally installed on the starboard side. If required, the operators cab may be installed on the port side. This procedure is typical for installation on the starboard side, unless otherwise noted.

1. Remove shipping plate (1) from starboard propulsion module engine hatch (2).



- a. Remove 14 bolts (3) securing shipping plate (1) to starboard propulsion module engine hatch (2). Bolts will be reused for installation of operators cab.

WARNING

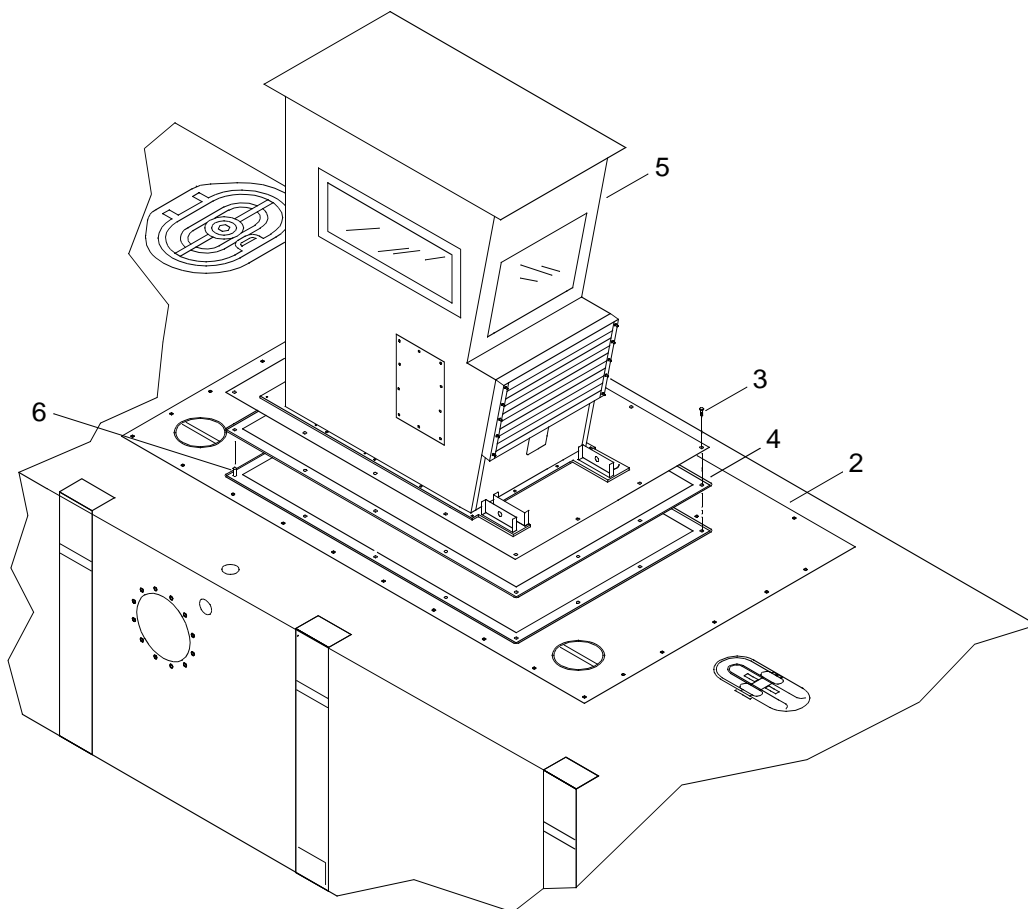
**HEAVY PARTS**

- b. Using crane, slings and shackles, remove shipping plate (1) from propulsion module engine hatch (2).

NOTE

When removing starboard propulsion module engine hatch shipping plate the gasket will remain on engine hatch.

- c. Remove gasket (4), if required.
 - d. Remove slings and shackles.
 - e. Stow shipping plate (1).
2. Install operators cab (5) on starboard propulsion module engine hatch (2).



- a. Remove operators cab (5) from shipping crate. (WP 0060 20)
- b. Install four guide pins (6) on corners to align and install operators cab (5).

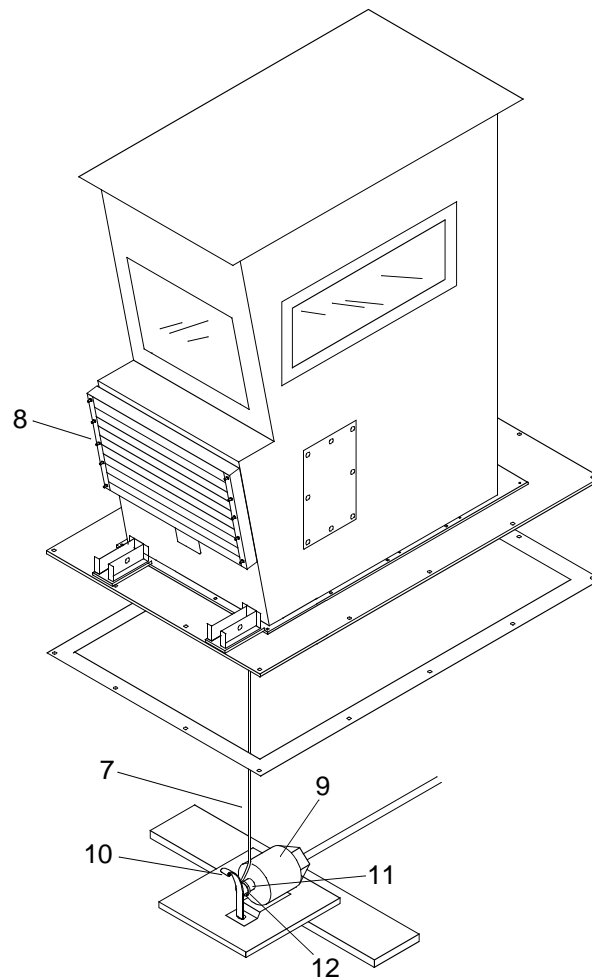
- c. Install new gasket (4), if removed.

WARNING



HEAVY PARTS

- d. Using crane, slings and shackles, align operators cab mounting holes with guide pins (6), lower operators cab (5) on propulsion module engine hatch (2).
- e. Remove guide pins (6).
- f. Install 14 bolts (3) securing operators cab (5) onto propulsion module engine hatch (2).
- g. Tighten bolts (3) using cross method.
- h. Remove slings and shackles.
- i. Connect wire rope (7) in operators cab intake plenum (8) to fire suppression trip mechanism (9).



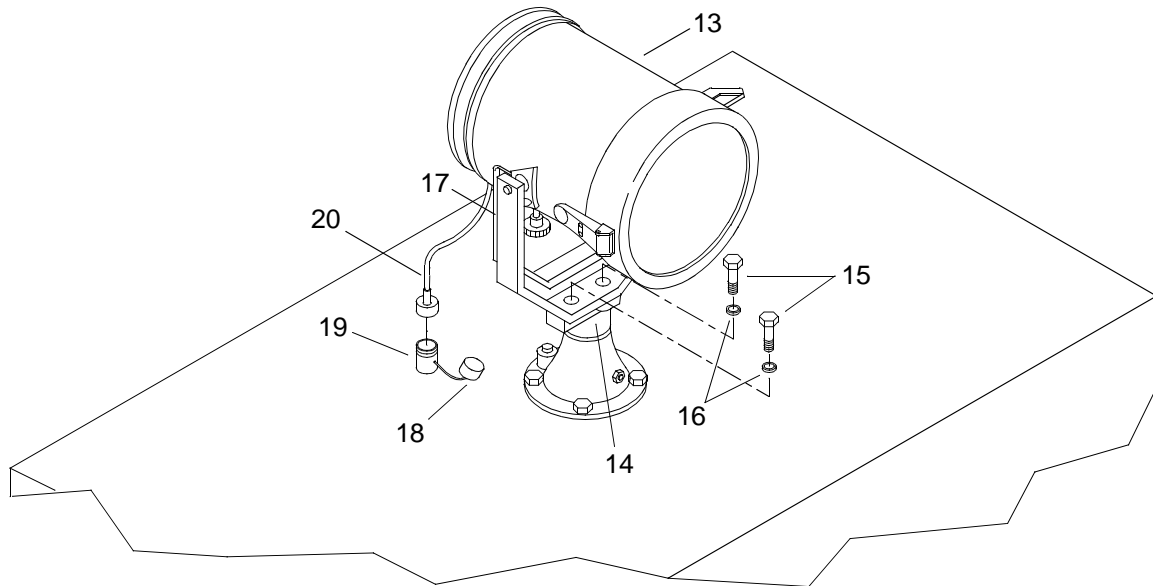
{1} Move fire suppression solenoid spring flange (10) away from solenoid shaft (11).

{2} Install wire rope ring (12) on the fire suppression solenoid shaft (11).

{3} Release flange (10).

3. Gain access to top of operators cab (5).

4. Install operators cab spotlight (13).



a. Using crane, sling and shackle, position spotlight (13) on spotlight flange tube (14).

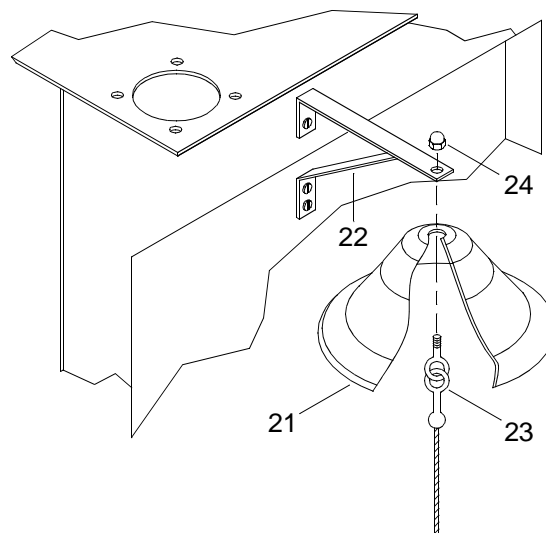
b. Install two bolts (15) with washers (16) through spotlight harp (17) to spotlight flange tube (14).

c. Tighten bolts (15).

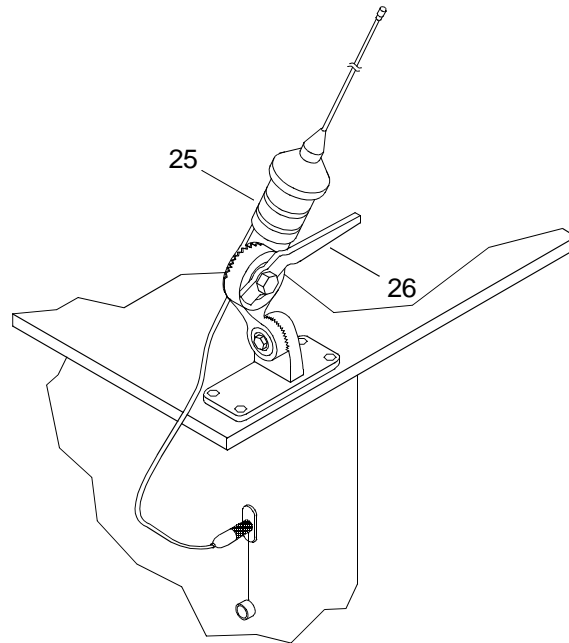
d. Remove sling and shackle.

e. Remove dust cap (18) from the receptacle (19) and connect spotlight electrical connector (20).

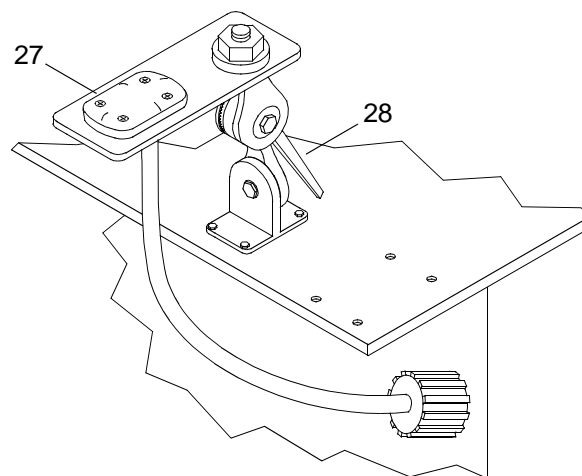
5. Install navigation bell (21).



- a. Align hole in top of navigation bell (21) with hole in mounting bracket (22).
 - b. Install clapper bolt (23) through navigation bell (21) and mounting bracket (22).
 - c. Install nut (24) and tighten.
6. Reposition VHF/FM DSC transceiver antenna (25).



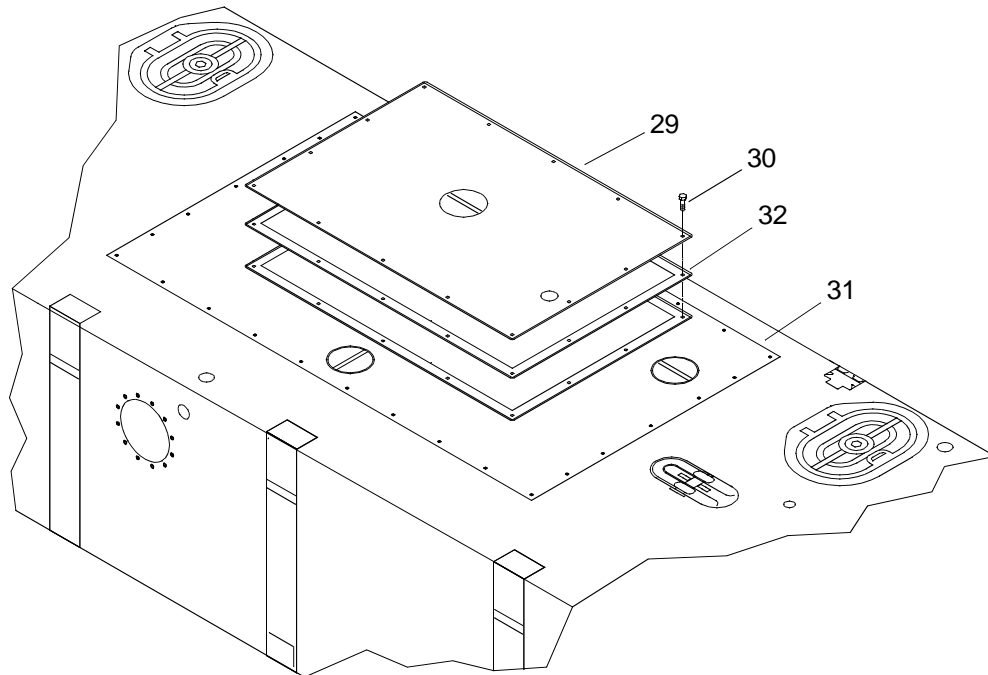
- a. Loosen handle (26) on VHF/FM DSC transceiver antenna ratchet mount counterclockwise and rotate antenna to vertical position.
 - b. Tighten handle (26) on VHF/FM DSC transceiver antenna ratchet mount clockwise to secure mount.
7. Reposition GPS antenna (27).



- a. Loosen handle (28) on GPS antenna ratchet mount counterclockwise and rotate antenna mount plate to horizontal position.
- b. Tighten handle (28) on GPS antenna ratchet mount clockwise to secure mount.

INSTALL AIR INTAKE PLENUM

1. Remove port propulsion module engine hatch shipping plate (29).



- a. Remove 14 bolts (30) securing port propulsion module engine hatch shipping plate (29) to port propulsion module engine hatch (31). Bolts will be reused for installation of the intake plenum.

WARNING

**HEAVY PARTS**

- b. Using crane, sling and shackle, remove port propulsion module engine hatch shipping plate (30).

NOTE

When removing engine hatch shipping plate the gasket will remain on engine hatch.

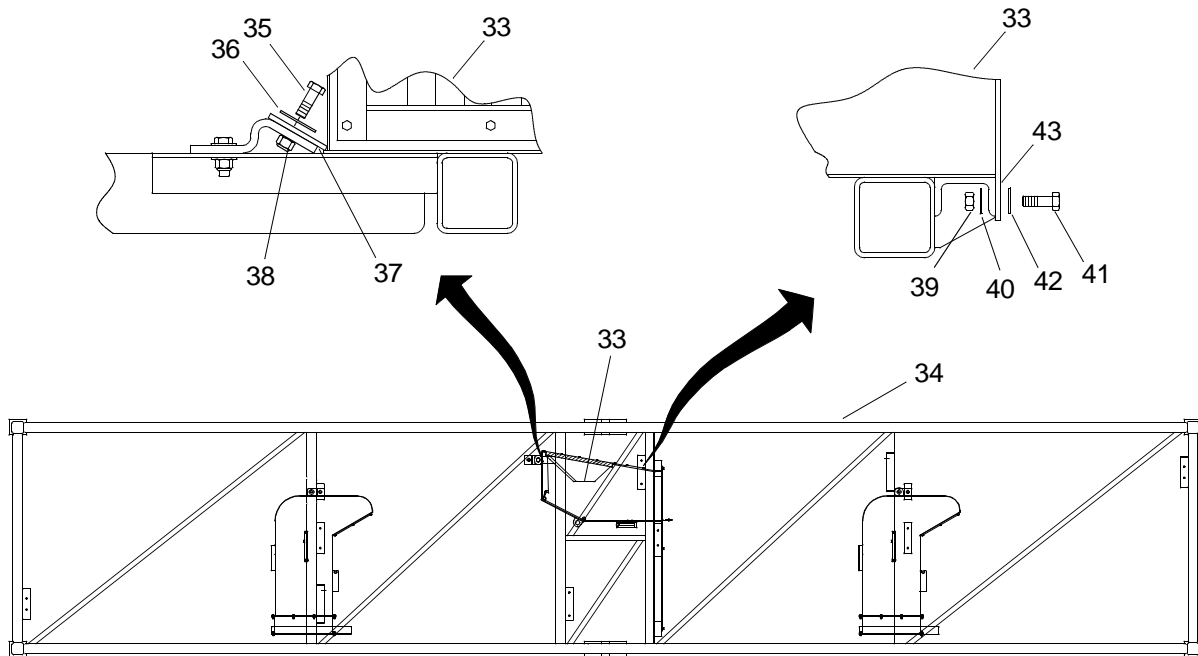
- c. Remove gasket (32), if required.
- d. Remove sling and shackle.
- e. Stow shipping plate (29).

 WARNING



HEAVY PARTS

2. Remove intake plenum (33) from shipping rack (34).



 WARNING



HEAVY PARTS

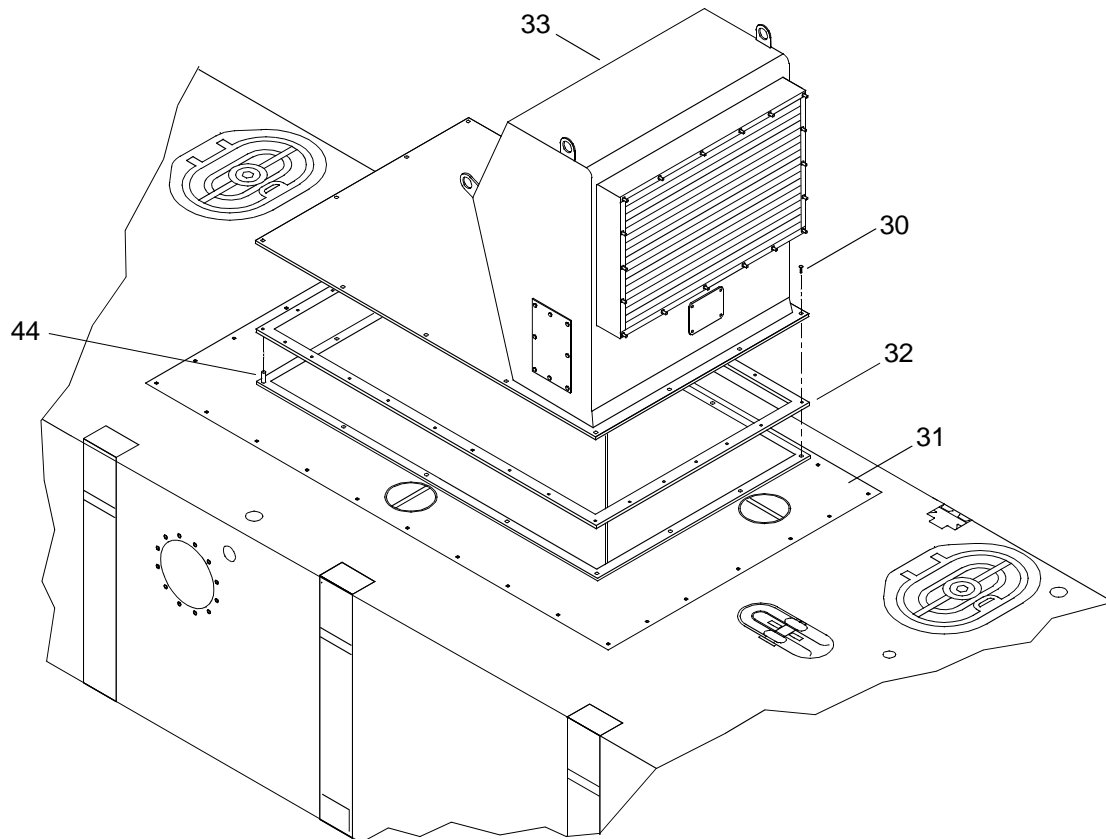
- a. Using crane, slings and shackles, support intake plenum (33) in preparation of removal from shipping rack (34).
- b. Remove bolt (35) and washer (36), securing top of plenum to shipping rack bracket (37), from welded nut (38).
- c. Remove two nuts (39), washers (40) and bolts (41) with washer (42) securing base of intake plenum shipping rack bracket (43).

 WARNING



HEAVY PARTS

- d. Using crane, slings and shackles, remove plenum (33) from shipping rack (34).
 - e. Install plenum mounting hardware (35, 36, 39, 40, 41 and 42) into shipping rack (34).
3. Install intake plenum (33) on port propulsion module engine hatch (31).



- a. Install four guide pins (44) on corners to align and install intake plenum (33).
- b. Install new gasket (32), if removed.

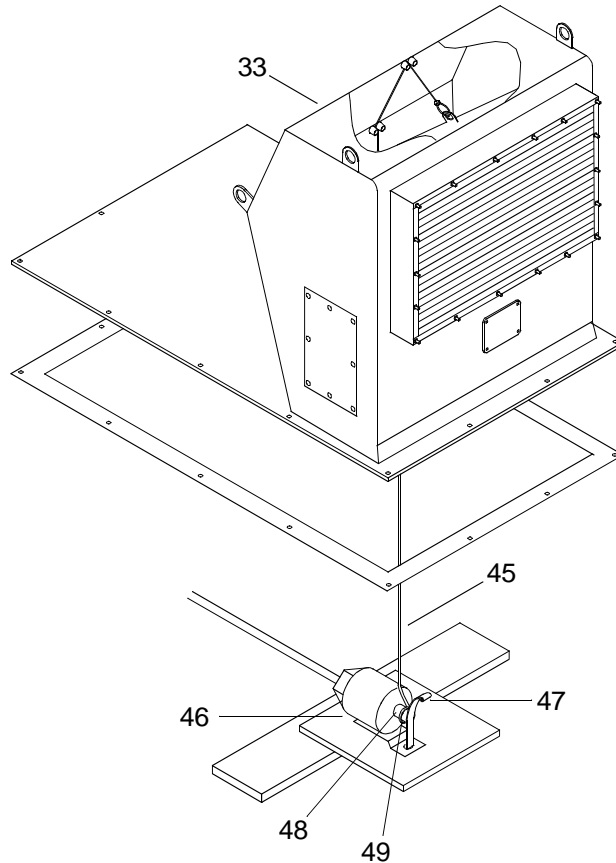
 WARNING



HEAVY PARTS

- c. Using crane, slings and shackles, align intake plenum mounting holes with guide pins (44), lower intake plenum (33) on propulsion module engine hatch (31).

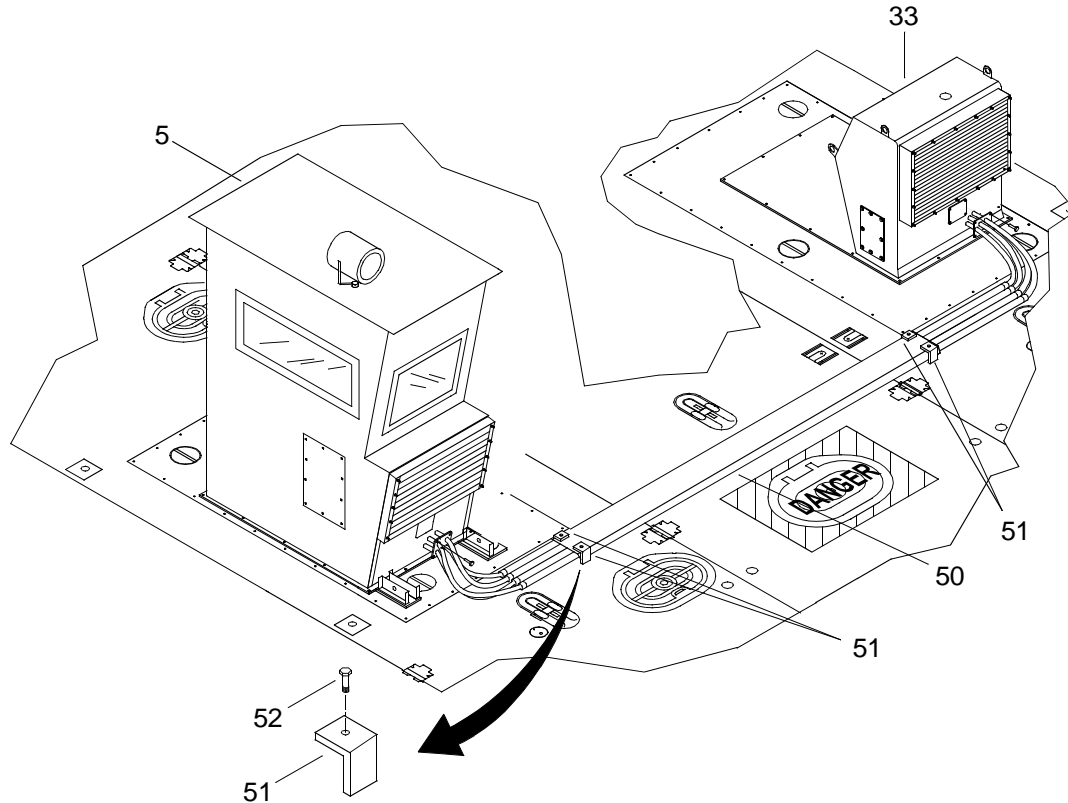
- d. Remove guide pins (44).
- e. Install 14 bolts (30) securing plenum (33) into propulsion module engine hatch (31).
- f. Tighten bolts (30) using cross method.
- g. Remove slings and shackles.
- h. Connect wire rope (45) in the intake plenum (33) to the fire suppression trip mechanism (46).



- {1} Move fire suppression solenoid spring flange (47) away from solenoid shaft (48).
- {2} Install wire rope ring (49) on the fire suppression solenoid shaft (48).
- {3} Release flange (47).

INSTALL MODULE ELECTRICAL INTERCONNECT ASSEMBLY**WARNING****HEAVY PARTS**

1. Using crane, slings and shackles, lower the interconnect assembly (50) onto the CF, between the operators cab (5) and the intake plenum (33).



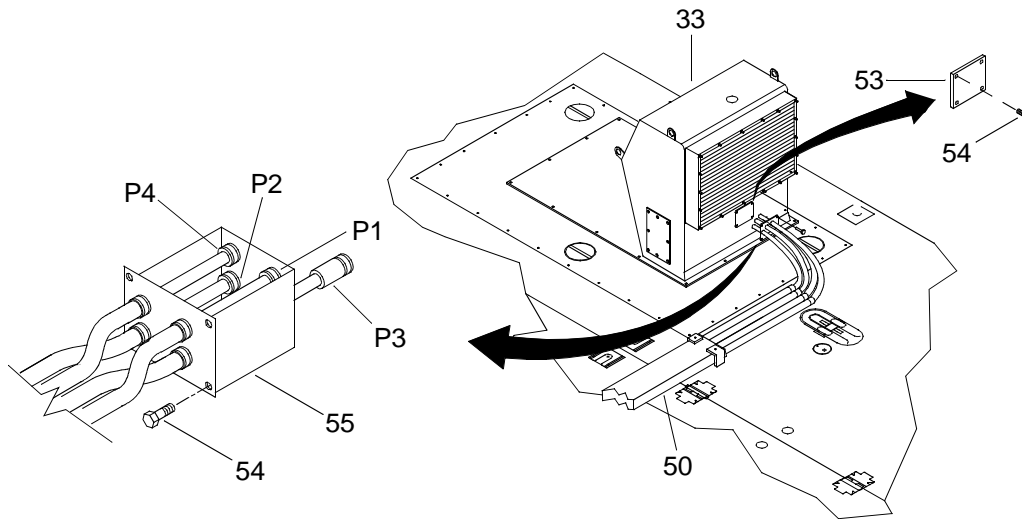
2. Remove slings and shackles.
3. Rotate four hold down clamps (51) into position over interconnect assembly (50) and tighten four allen head bolts (52).

CAUTION

When installing the operators cab on the starboard side, the interconnect cable must be connected to the operators cab port receptacle (A6) to ensure operators control of the port engine. Failure to make proper connection could result in damage to equipment.

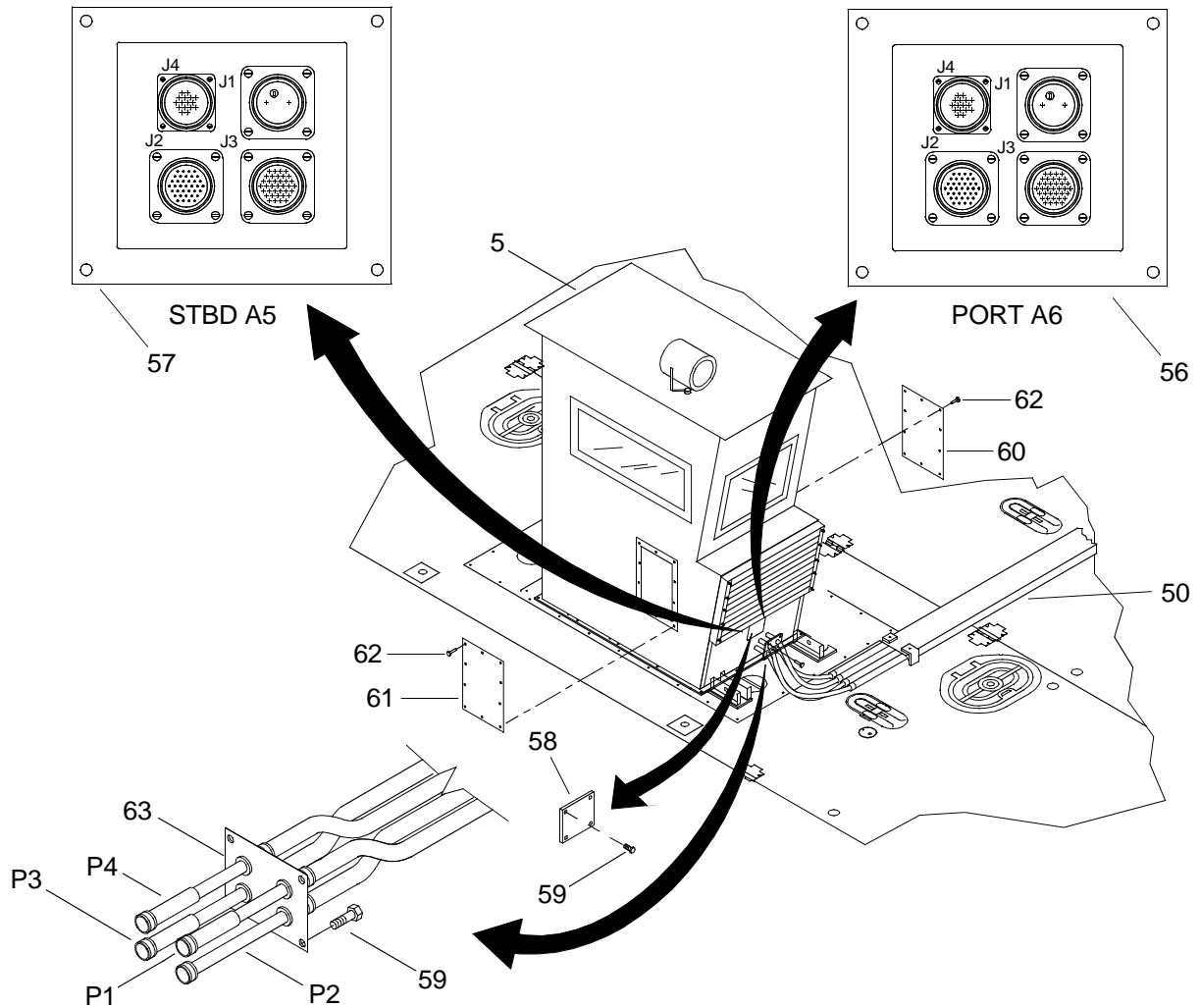
When connecting interconnect cables, do not use excessive force, as damage to equipment could occur.

4. Connect interconnect cables (50) to intake plenum receptacles.



- a. Remove intake plenum front access panel (53).
 - {1} Remove bolts (54) securing front access panel (53) to intake plenum (33).
 - {2} Remove access panel (53).
- b. Insert cables (50) into intake plenum (33) front access.
- c. From below deck, connect power module cables to interconnect cable receptacles.
 - {1} Connect power module junction box A3, P2 to interconnect cable, P2.
 - {2} Connect power module junction box A3, P4 to interconnect cable, P4.
 - {3} Connect power module junction box A3, P3 to interconnect cable, P3.
 - {4} Connect power module A6, P1 to interconnect cable, P1.
- d. Install conduit entry plate (55) to air intake plenum (33).
 - {1} Align entry plate holes with holes in intake plenum (33).
 - {2} Install four bolts (54) through plate (55) into intake plenum (33).
 - {3} Tighten bolts (54).

5. Connect interconnect cables (50) and power module cables to operators cab receptacles (56 and 57).



- a. Remove operators cab front access panel (58).
 - {1} Remove screws (59) securing front access panel (58) to operators cab (5).
 - {2} Remove access panel (58).
- b. Remove operators cab portside and starboard side access panels (60 and 61).
 - {1} Remove screws (62) securing side access panels (60 and 61) to operators cab (5).
 - {2} Remove side access panels (60 and 61).
- c. Insert interconnect cables (50) through operators cab (5) front access.
- d. Connect interconnect cables (50) to operators cab PORT receptacle A6 (56).
 - {1} Connect P2 to PORT A6, J2.
 - {2} Connect P4 to PORT A6, J4.

-
- {3} Connect P3 to PORT A6, J3.
 - {4} Connect P1 to PORT A6, J1.
 - e. Connect P1 to PORT A6, J1.
 - f. Connect the power module cables to STBD receptacle A5 (57).
 - {1} Connect power module A6, P2 to STBD A5, J2.
 - {2} Connect power module A6, P4 to STBD A5, J4.
 - {3} Connect power module A6, P3 to STBD A5, J3.
 - {4} Connect power module A3, P1 to STBD A5, J1.
 - g. Secure conduit entry plate (63) to the operators cab (5).
 - {1} Align entry plate holes with holes in operators cab (5).

WARNING



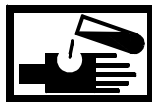
CHEMICAL



EYE PROTECTION

- {2} Apply adhesive to threads of screws (59).
- {3} Install screws (59) through entry plate (63) into operators cab (5).
- {4} Tighten screws (59).
- h. Install both operators cab side access panels (60 and 61).
 - {1} Align panel (60) holes with holes in operators cab (5).

WARNING



CHEMICAL



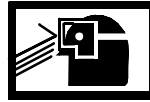
EYE PROTECTION

- {2} Apply adhesive to threads of screws (62).
- {3} Install ten screws (62) through side access panel (60) into operators cab (5).
- {4} Tighten screws (62).
- {5} Align panel (61) holes with holes in operators cab (5).

 WARNING



CHEMICAL



EYE PROTECTION

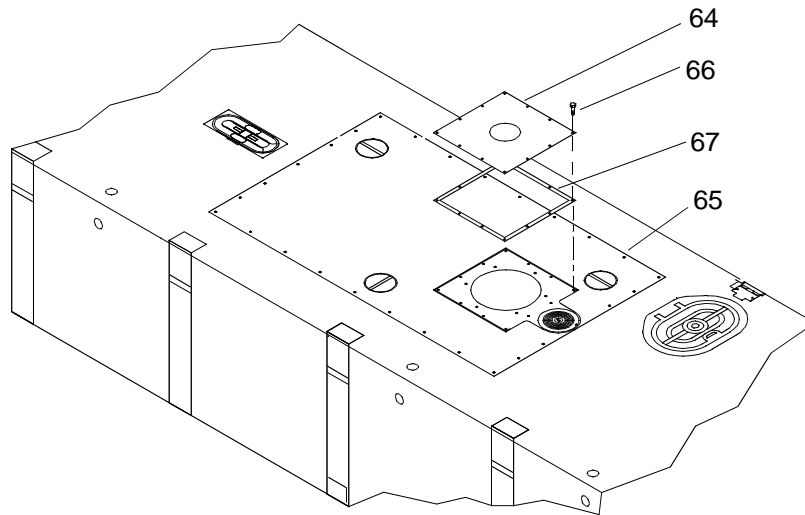
- {6} Apply adhesive to threads of screws (62).
- {7} Install ten screws (62) through side access panel (61) into operators cab (5).
- {8} Tighten screws (62).

INSTALL PORT AND STARBOARD EXHAUST PLENUMS

NOTE

These procedures are typical for both port and starboard exhaust plenums.

1. Remove propulsion module shipping plate (64) from pump-jet thruster hatch (65).



- a. Remove 12 bolts (66) securing propulsion module pump-jet thruster hatch shipping plate (64) to propulsion module pump-jet thruster hatch (65).

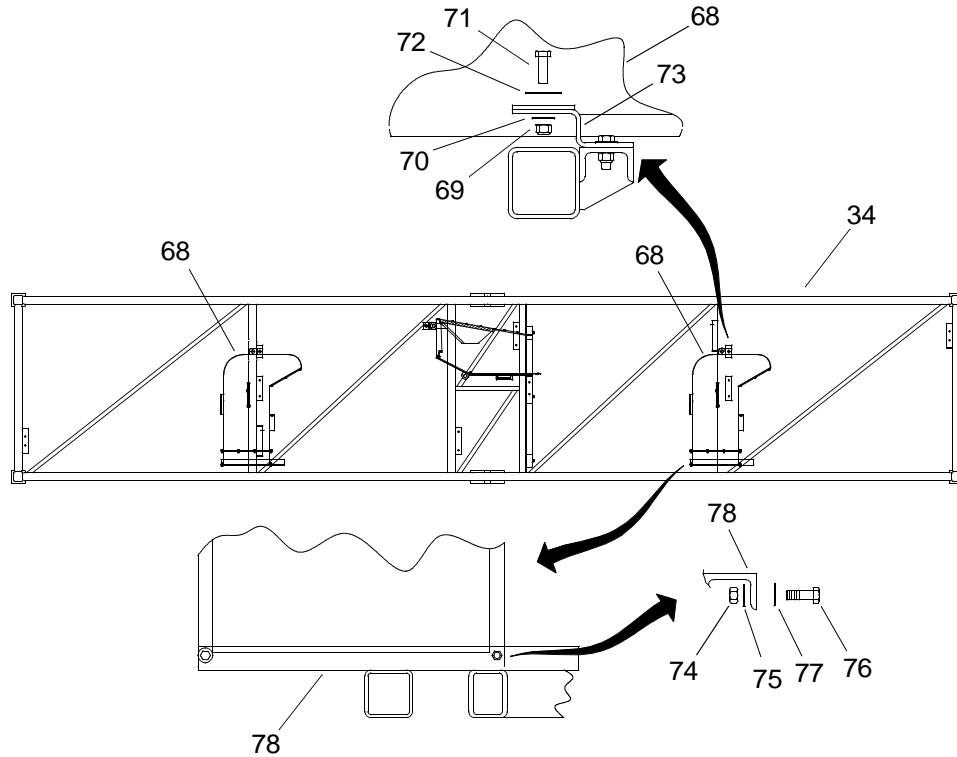
 WARNING



HEAVY OBJECTS

- b. Remove propulsion module pump-jet thruster hatch shipping plate (64).
- c. Remove gasket (67), if required.
- d. Stow shipping plate (64).

2. Remove propulsion module exhaust plenum (68) from shipping rack (34).



WARNING



HEAVY PARTS

- Using crane, slings and shackles, support propulsion module exhaust plenum (68) in preparation for removal from shipping rack (34).
- Remove nut (69), washer (70), bolt (71) and fender washer (72) securing top of plenum (68) to shipping rack bracket (73).
- Remove two nuts (74), washers (75), bolts (76) and washers (77) securing bottom of plenum (68) to shipping rack bracket (78).

WARNING



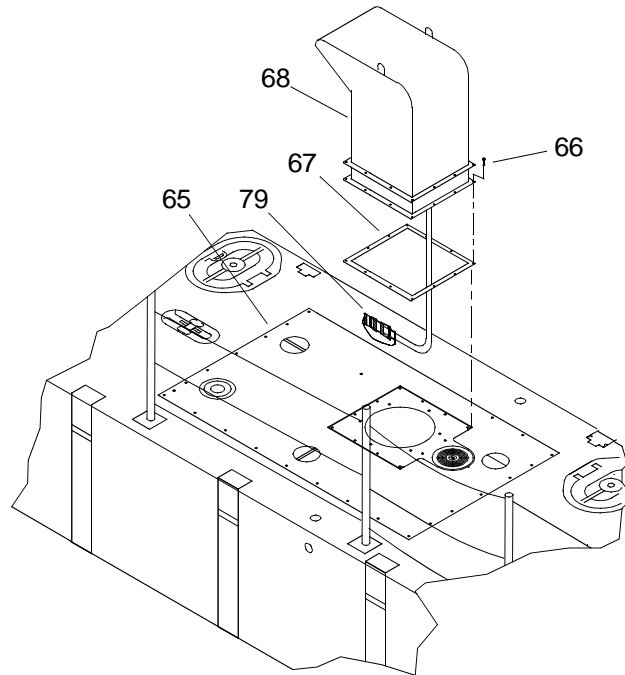
HEAVY PARTS

- Using crane remove propulsion module exhaust plenum (68) from shipping rack (34).
- Install plenum mounting hardware (69, 70, 71, 72, 74, 75, 76 and 77) into shipping rack (34).

WARNING

**HEAVY PARTS**

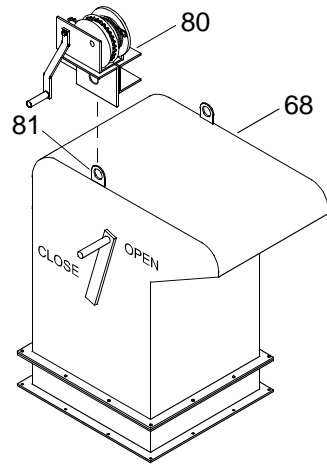
3. Position exhaust plenum (68), with the grating facing aft, over propulsion module pump-jet thruster hatch (65).



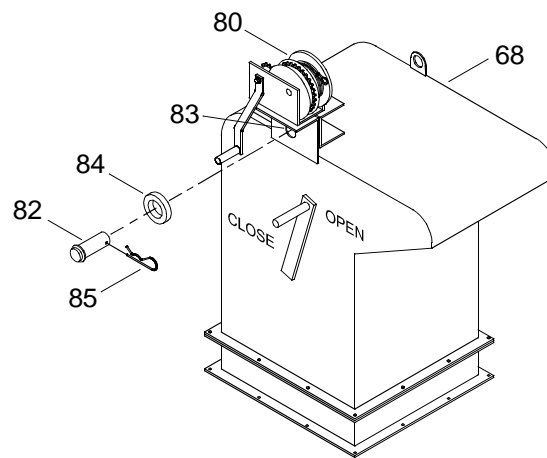
4. Install exhaust plenum (68) on propulsion module pump-jet thruster hatch (65).
 - a. Align holes in base of exhaust plenum (68) with holes in propulsion module pump-jet thruster hatch (65).
 - b. Install new gasket (67), if required.
 - c. Install 12 bolts (66) through exhaust plenum (68) into holes in propulsion module pump-jet thruster hatch (65).
 - d. Tighten bolts (66).
 - e. Remove slings and shackles.
5. Connect exhaust plenum fan cable (79) to vent fan relay enclosure A8.

INSTALL MAIN MAST WINCH

1. Install main mast winch assembly (80) on exhaust plenum (68).
2. Place winch (80) on inboard lifting shackle (81) of exhaust plenum (68).



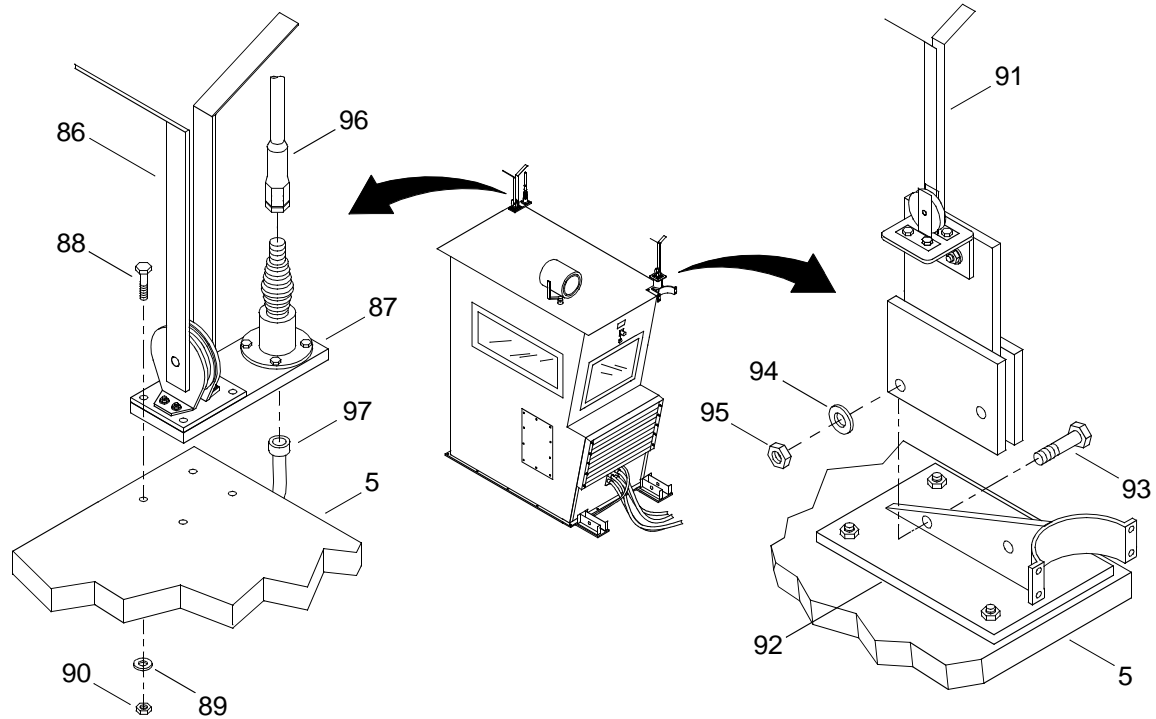
3. Install pipe assembly (82) through winch mounting hole (83).



4. Install large washer (84) on pipe assembly (82).
5. Install clevis pin (85) in pipe assembly (82).

INSTALL WIRE ROPE SHEAVES AND SINGGAR ANTENNA

1. Gain access to top of operators cab (5) using steps on side of cab.

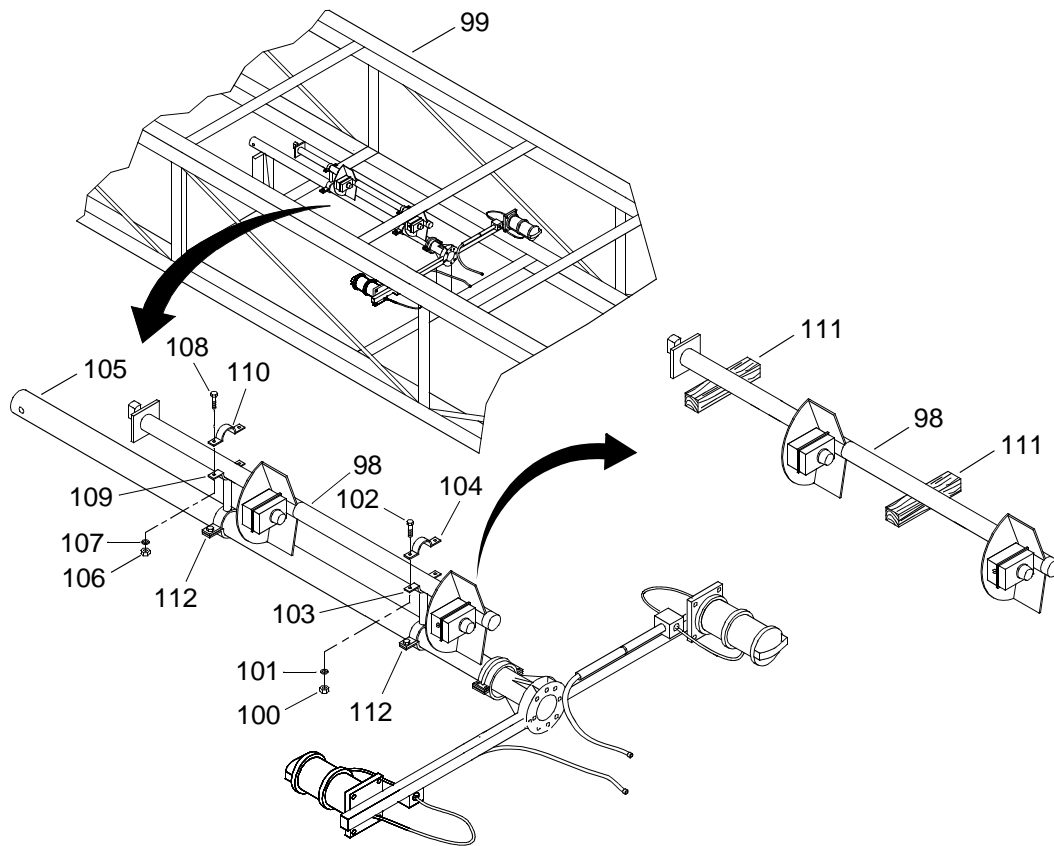


2. Position combination rear sheave (86) and SINGGAR antenna mount (87) on rear of cab (5) roof and secure with bolts (88), washers (89) and nuts (90). Tighten nuts (90).
3. Position front sheave (91) with mount on cab mast clamp mount (92) and secure with bolts (93), washers (94) and nuts (95). Tighten nuts (95).
4. Install SINGGAR antenna (96) on spring base of SINGGAR antenna mount (87) and tighten.
5. Connect SINGGAR antenna cable connector (97) to bottom of SINGGAR antenna mount (87) and tighten.

INSTALL MAIN NAVIGATION MAST ASSEMBLY**WARNING****HEAVY OBJECTS**

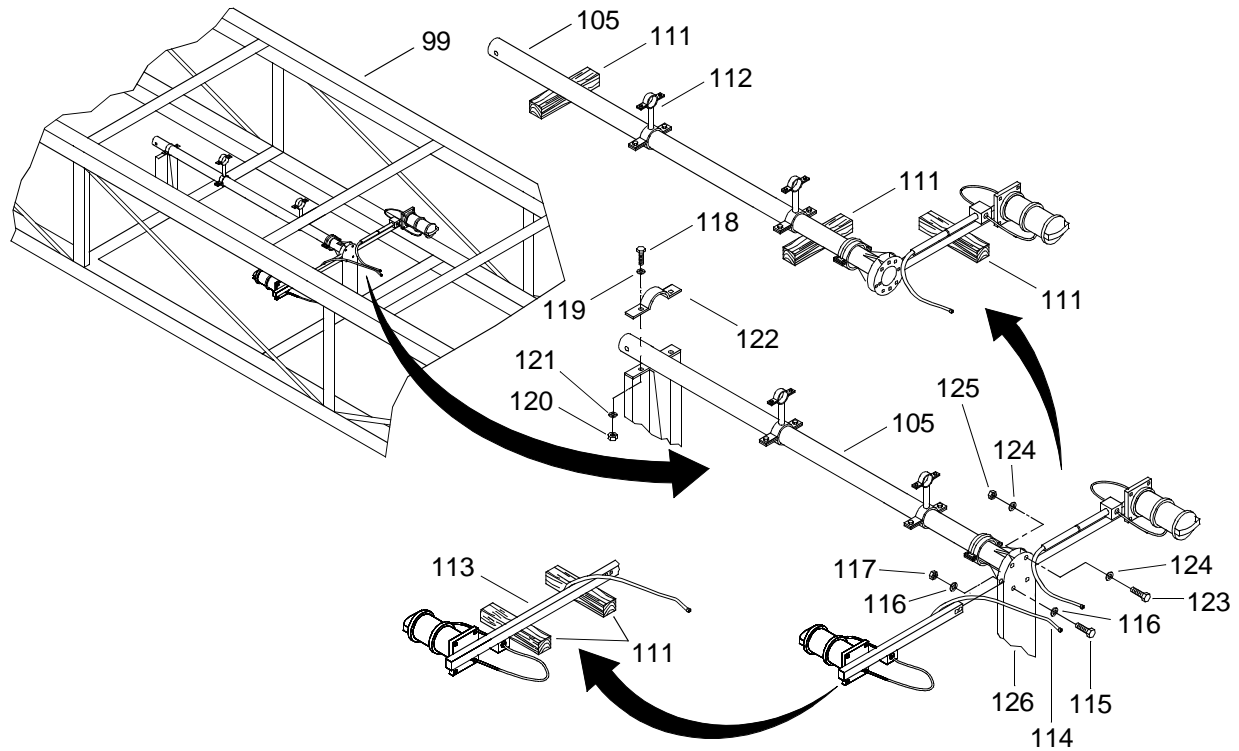
Removal of the stub mast requires two man lift. Failure to comply could result in injury to personnel and/or damage to equipment.

1. Using an assistant, remove stub mast (98) from shipping rack (99).



- a. Remove two nuts (100), washers (101) and bolts (102) from clamp halves (103 and 104) attaching upper end of stub mast (98) to lower main mast (105).
- b. Remove two nuts (106), washers (107) and bolts (108) from clamp halves (109 and 110) attaching lower end of stub mast (98) to lower main mast (105).
- c. Using an assistant, remove stub mast (98) from lower main mast (105) and shipping rack (99).
- d. Place stub mast (98) on wooden shoring blocks (111).
- e. Install clamp half (104) on clamp half (103) of stub mast mounts (112).
 - {1} Align removable clamp half (104) holes with clamp half (103) holes.
 - {2} Install two bolts (102), washers (101) and nuts (100).
 - {3} Tighten nuts (100).
- f. Install clamp half (110) on clamp half (109) of stub mast mounts (112).
 - {1} Align removable clamp half (110) holes with clamp half (109) holes.
 - {2} Install two bolts (108), washers (107) and nuts (106).
 - {3} Tighten nuts (106).

2. Remove lower main mast (105) from shipping rack (99).



WARNING



HEAVY PARTS

NOTE

This step is typical for both the port and starboard yardarms.

- a. Remove lower main mast yardarm (113).
 - {1} Disconnect yardarm electrical cable connector (114).
 - {2} Remove two bolts (115) with washers (116) and nuts (117) securing yardarm (113) to lower main mast (105). Retain hardware for installation of yardarm during assembly.
 - {3} Remove yardarm (113) from lower main mast (105) and place on wooden shoring blocks (111).
- b. Remove two bolts (118) with washers (119), nuts (120) and washers (121) securing lower main mast (105) to shipping rack (99).
- c. Remove upper clamp half (122).

 WARNING



HEAVY PARTS

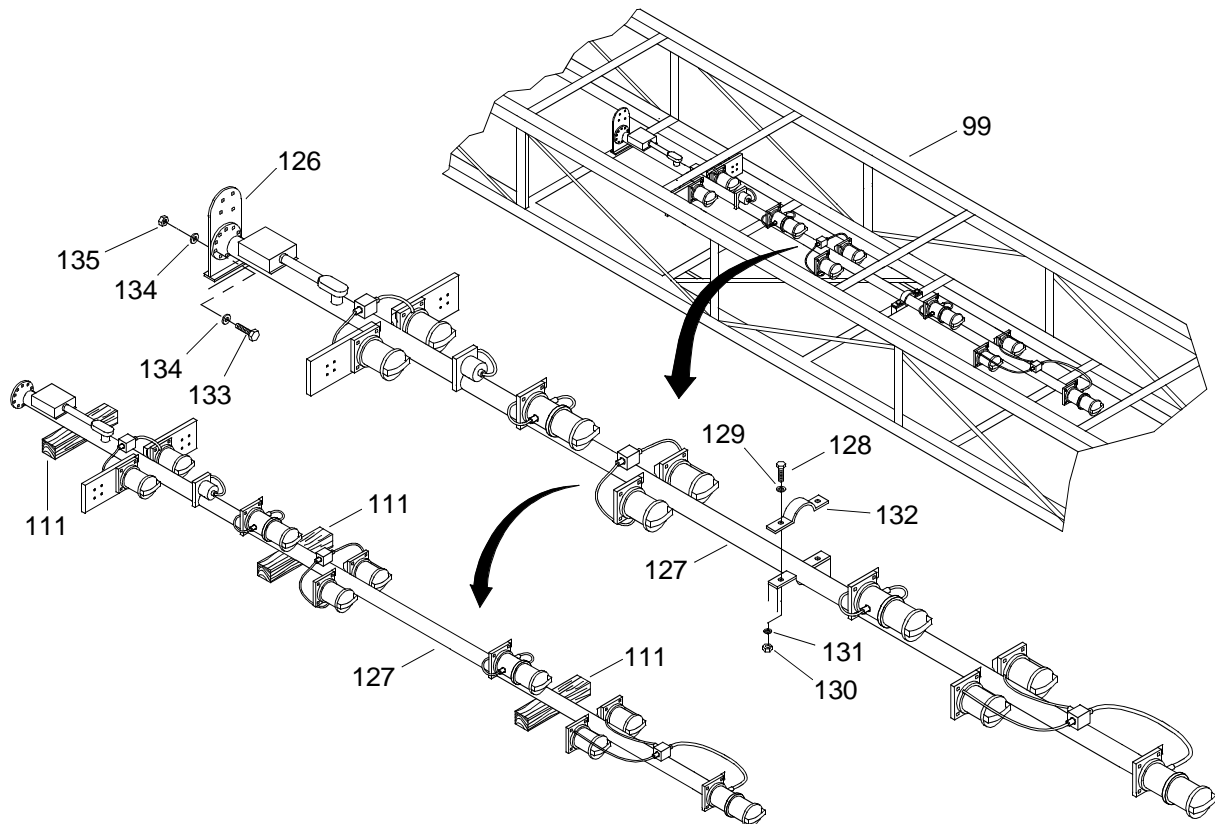
- d. Using crane, slings and shackles to support the lower main mast (105), remove four bolts (123) with washers (124) and nuts (125) securing lower main mast base to shipping rack bracket (126).

 WARNING



HEAVY PARTS

- e. Remove lower main mast (105) from shipping rack (99) and place mast on wooden shoring blocks (111).
- f. Remove slings and shackles.
3. Remove upper main mast (127) from shipping rack (99).

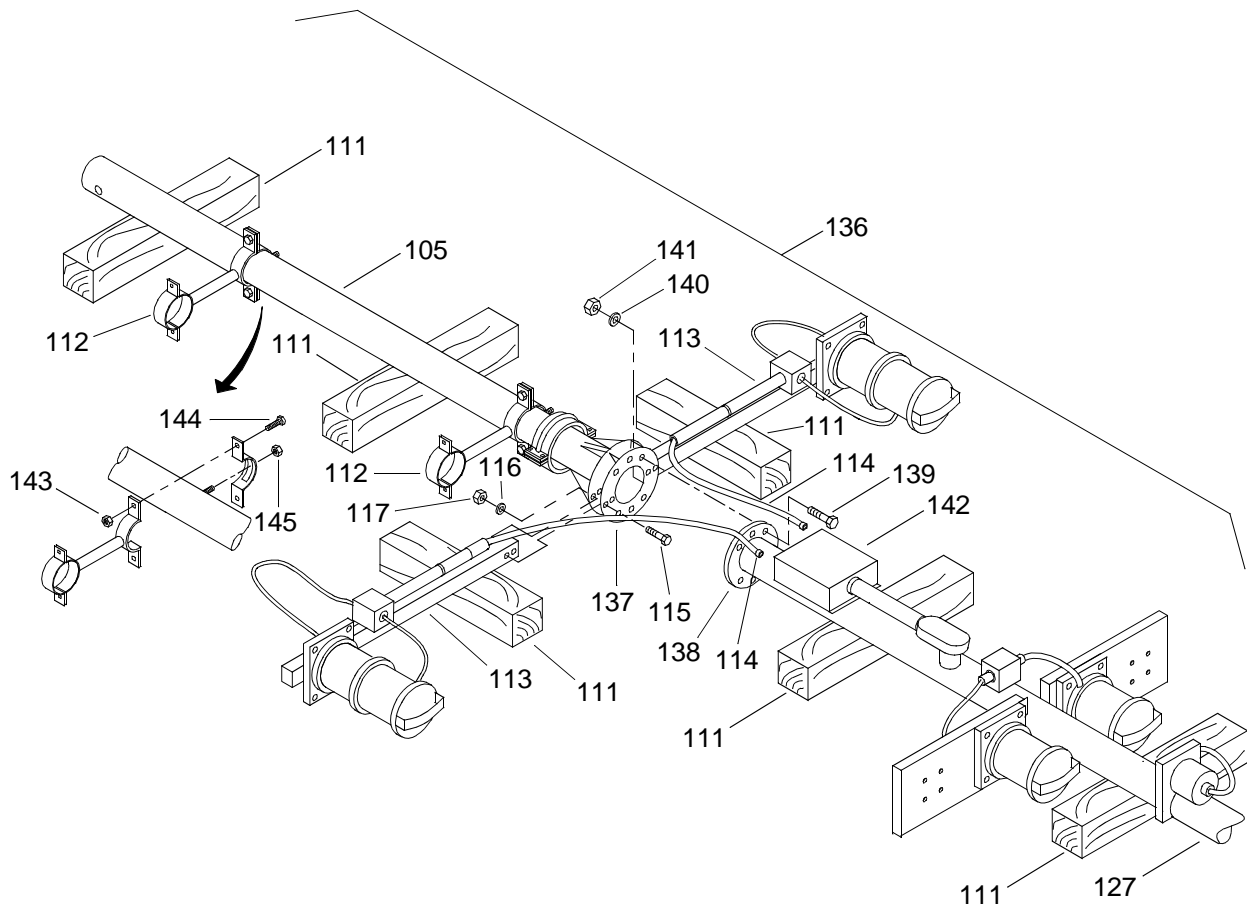


- a. Remove two bolts (128) with washers (129), nuts (130) and washers (131) securing upper main mast (127).
- b. Remove upper clamp half (132).

WARNING

**HEAVY PARTS**

- c. Using crane, slings and shackles to support the upper main mast (127), remove four bolts (133) with washers (134) and nuts (135) securing upper main mast (127).
 - d. Remove upper main mast (127) from shipping rack (99) and place on wooden shoring blocks (111).
 - e. Remove slings and shackles.
 - f. Install upper clamp half (132) on to shipping rack (99), using bolt (128) with washer (129), nut (130) with washer (131).
 - g. Install upper clamp half (122) on to shipping rack (99), using bolt (118) with washer (119), nut (120) with washer (121).
4. Assemble main navigation mast assembly (136).



WARNING

**HEAVY PARTS**

- a. Using crane, slings and shackles, position lower main mast and upper main mast assemblies (105, 127) in suitable location for assembly and place on wooden shoring blocks (111).
- b. Align holes in lower main mast weldment (137) with holes in upper main mast weldment (138).
- c. Install six bolts (139), washers (140) and nuts (141) through upper main mast weldment (138) and lower main mast weldment (137). Do not tighten nuts (141).

WARNING

**HEAVY PARTS****NOTE**

This step is typical for both port and starboard yardarms.

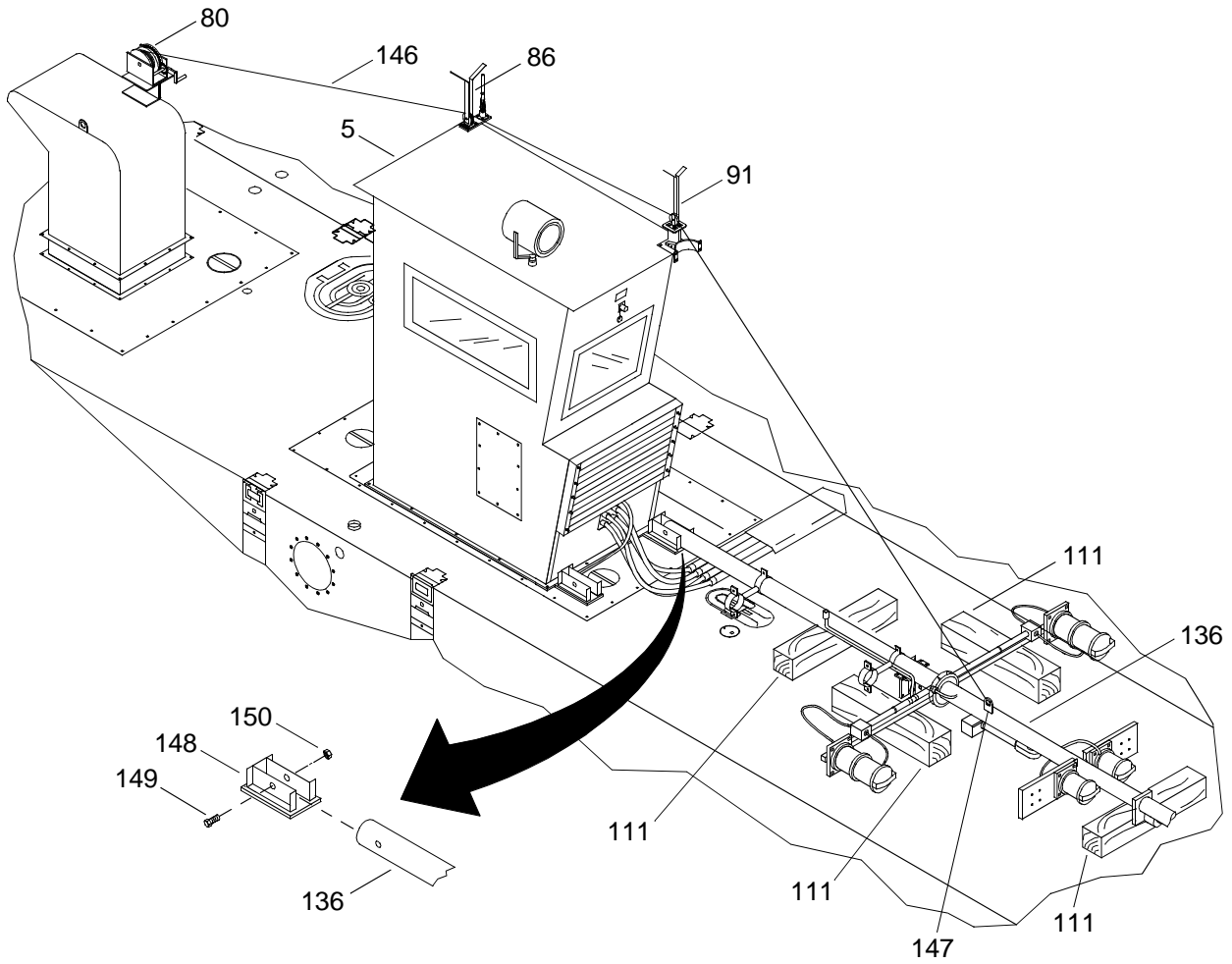
- d. Install lower main mast yardarm (113).
 - {1} Install yardarm (113) into lower main mast weldment (137).
 - {2} Align holes and install two bolts (115), washers (116) and nuts (117) through lower main mast weldment (137) and yardarm (113).
 - {3} Tighten nuts (117) and (141).
 - {4} Connect yardarm electrical cable connector (114) to mast junction box (142).
- e. Loosen nuts and bolts (143 and 144) on stub mast mounts (112).
- f. Loosen nuts (145) on stub mast mounts (112).
- g. Turn stub mast mounts (112) 90° counterclockwise.
- h. Tighten nuts and bolts (143 and 144).
- i. Tighten nuts (145).

WARNING



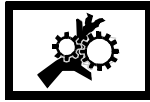
HEAVY PARTS

5. Install main navigation mast assembly (136).



a. Connect wire rope (146) to padeye (147) on main navigation mast assembly (136).

WARNING

**MOVING PARTS**

Failure to maintain control of the winch handle during operation of the winch may result in serious injury and or death to personnel.

NOTE

It may be necessary to turn the handle on the winch slightly (pull wire rope in) in order to disengage the ratcheting device.

- {1} Place the winch (80) in the neutral or reverse position.
 - {2} Gain access to top of operators cab (5) using steps on side of cab.
 - {3} As assistant lets wire rope (146) out of winch (80), guide wire rope (146) through rear sheave (86) and forward sheave (91).
 - {4} Descend from top of operators cab (5).
 - {5} Attach wire rope (146) to padeye (147).
- b. Using crane, sling and shackle, lift mast (136) to position main mast base into deck holder (148).
 - c. Align holes in base of main mast (136) with holes in deck holder (148).
 - d. Install bolt (149) and hex nut (150), do not tighten nut.

RAISE MAIN MAST ASSEMBLY

WARNING

**MOVING PARTS**

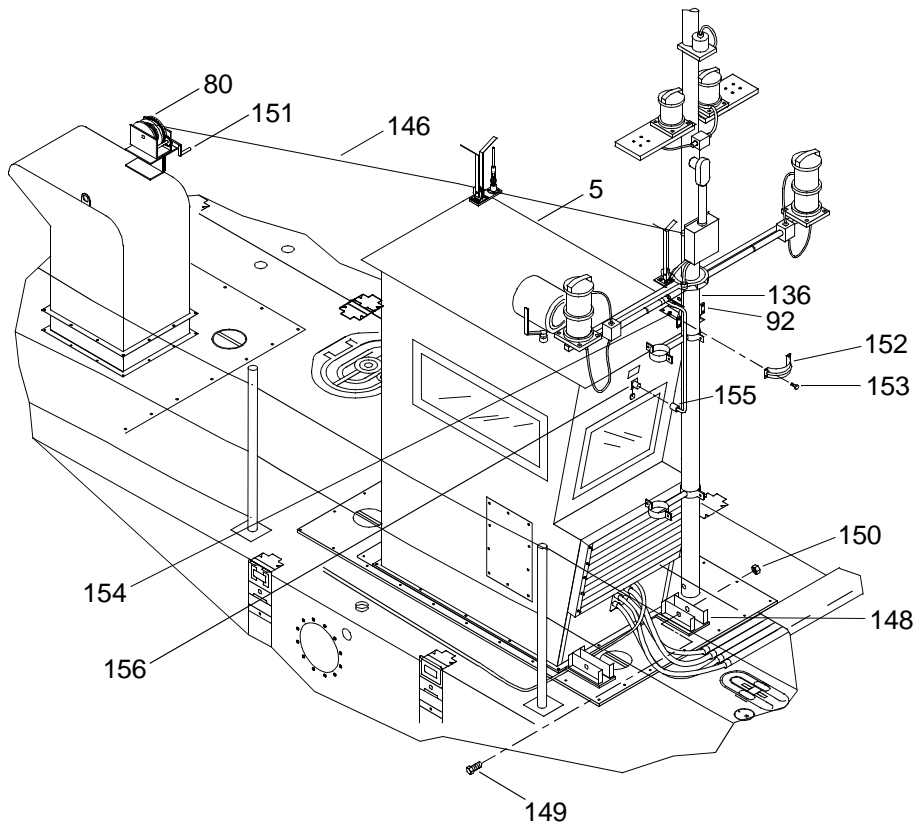
Prior to operating the mast winch, always engage the ratchet in the hold position. Failure to comply could result in serious injury to personnel and/or damage to equipment.

Before raising the main mast, the ratchet must snap into engagement. Failure to comply could result in serious injury to personnel and/or damage to equipment.

NOTE

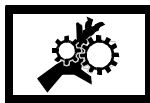
Prior to operating the mast winch, read the Cable In/Cable Out Decal located on the winch housing.

- 1. Using main mast winch (80), lift mast assembly (136).



- a. Visually inspect mast winch cable (146) to ensure it is securely fastened to the main mast padeye (147).
- b. Place the mast winch ratchet in the hold position.

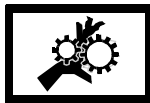
 WARNING



MOVING PARTS

- c. Turn crank handle (151) counterclockwise to actuate the automatic brake.

 WARNING



MOVING PARTS

Never release the crank handle unless the ratchet pawl is fully engaged and the main mast is securely fastened to the operator cab. Failure to comply could result in serious injury or death to personnel or damage to equipment.

- d. Turn crank handle (151) clockwise to raise main mast (136) until mast contacts operators cab mast clamp (92).

- e. Gain access to top of operators cab (5).
 - f. Install clamp outer half (152) using four capscrews (153) and hex nuts (154).
 - g. Tighten nuts (150 and 154).
 - h. Connect electrical connector (155) to operators cab connector (156).
2. Turn crank handle (151) counterclockwise to remove tension from mast winch cable (146).
 3. Remove mast winch cable (146) from main mast padeye (147).
 4. Turn crank handle (151) clockwise and coil mast winch cable (146) back onto winch (80).
 5. Descend from operators cab (5).

END OF WORK PACKAGE

**OPERATOR MAINTENANCE
CAUSEWAY FERRY
ANCHORBOARD ASSEMBLY
OPERATION UNDER USUAL CONDITIONS**

INITIAL SETUP:**Tools**

Tool Kit, General Mechanic's (Rail and Marine) (Item 76, WP 0105 00)
 Gloves, Men's and Women's (Leather Palm) (Item 31, WP 0105 00)
 Goggles, Sun, Wind and Dust (Safety) (Item 34, WP 0105 00)
 Life Preserver, Vest (Item 45, WP 0105 00)
 Helmet, Safety (Brown) (Item 40, WP 0105 00)
 Sling, Lifting 5300 lbs (Green) (Item 68, WP 0105 00)
 4 ¾ Ton ¾ in. Shackle (Item 5, WP 0105 00)

Personnel Required

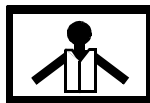
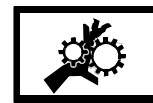
Seaman 88K

Equipment Condition

Module ISOPAK Disassembled. (WP 0007 00)
 Operation Of Male And Female Guillotine Connectors. (WP 0008 00)
 D-Ring/Cloverleaf Fittings And Deck Cleat Fittings Installed. (WP 0009 00)
 Module String Assembled. (WP 0010 00)
 Causeway Ferry Powered Section Assembled. (WP 0013 00)
 Causeway Ferry Above Deck Equipment Installed. (WP 0014 00)

PREPARATION FOR USE - INSTALLATION OF ANCHORBOARD ASSEMBLY**INSTALL ANCHORBOARD ASSEMBLY**

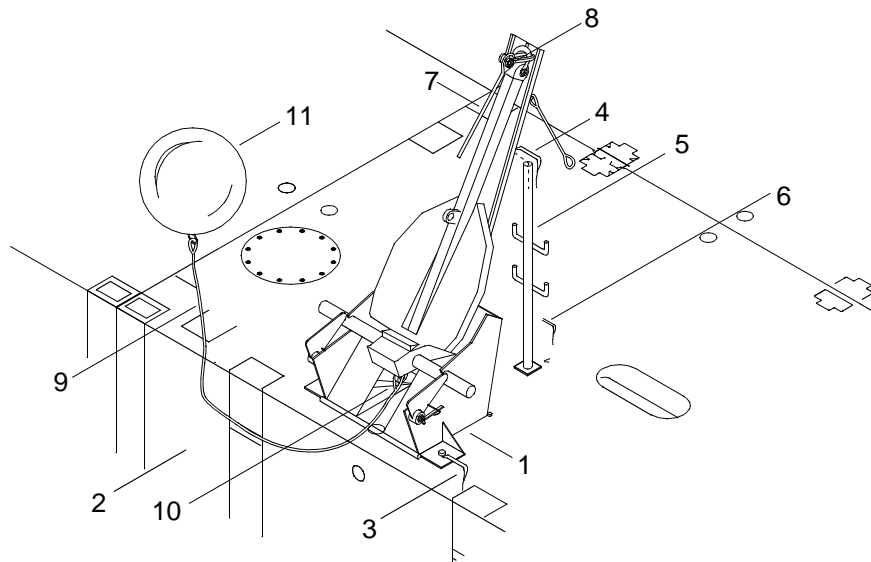
WARNING

**VEST****HELMET PROTECTION****HEAVY PARTS****MOVING PARTS**

All personnel must wear personal flotation device, hard hat, safety shoes and gloves during CF operations and maintenance. Failure to observe these precautions could result in serious injury or death.

The anchorboard weighs approximately 3500 pounds. Use proper hoisting and lifting equipment to prevent possible injury to personnel or damage to equipment.

1. Using crane, sling and shackle, align anchorboard assembly weldment (1) mounting holes with holes in starboard propulsion module (2) and place on deck.



2. Install three locking pins (3) securing anchorboard to deck.
3. Remove slings and shackles.
4. Install toggle pin with attached sash chain (4) securing anchorboard to stanchion (5).
5. Secure stanchion (5) to deck with locking pin (6).
6. Attach anchor rope (7) to top anchor shackle (8).
7. Attach one end of buoy line (9) to the base anchor shackle (10).
8. Attach one end of buoy line (9) to the buoy (11).

END OF WORK PACKAGE

**OPERATOR MAINTENANCE
CAUSEWAY FERRY
STUB NAVIGATION MAST
OPERATION UNDER USUAL CONDITIONS**

INITIAL SETUP:**Tools**

Tool Kit, General Mechanic's (Rail and Marine) (Item 76, WP 0105 00)
 Gloves, Men's and Women's (Leather Palm) (Item 31, WP 0105 00)
 Goggles, Sun, Wind and Dust (Safety) (Item 34, WP 0105 00)
 Life Preserver, Vest (Item 45, WP 0105 00)
 Helmet, Safety (Brown) (Item 40, WP 0105 00)

Materials/Parts

Battery, Non-Rechargeable
 PN EV90
 (83740)
 Qty 8

Personnel Required

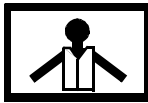
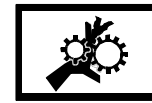
Seaman 88K (2)

Equipment Condition

Module ISOPAK Disassembled. (WP 0007 00)
 Operation Of Male And Female Guillotine Connectors. (WP 0008 00)
 D-Ring/Cloverleaf Fittings And Deck Cleat Fittings Installed. (WP 0009 00)
 Module String Assembled. (WP 0010 00)
 Causeway Ferry Powered Section Assembled On Deck Of Sealift Vessel. (WP 0013 00)
 Causeway Ferry Powered Section Assembled In Water. (WP 0013 10)
 Causeway Ferry Above Deck Equipment Installed. (WP 0014 00)
 Anchorboard Assembly Installed. (WP 0015 00)

PREPARATION FOR USE - INSTALL STUB NAVIGATION MAST

WARNING

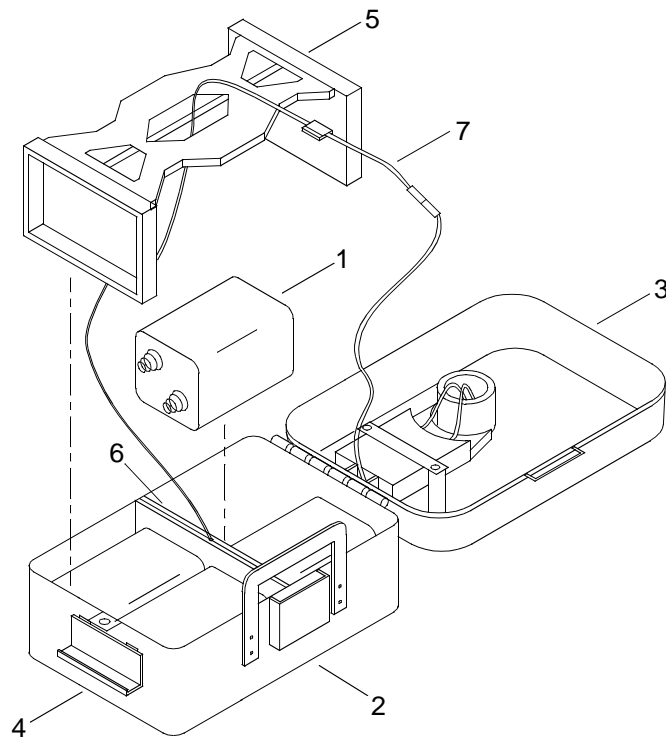
**VEST****HELMET PROTECTION****HEAVY PARTS****MOVING PARTS**

All personnel must wear personal flotation device, hard hat, safety shoes and gloves during CF operations and maintenance. Failure to observe these precautions could result in serious injury or death.

NOTE

This task is typical for installation of stub mast light batteries.

1. Install four batteries (1) in mast light (2).



- a. Open light cover (3) by unlatching clasp (4).
- b. Remove battery bracket (5).

NOTE

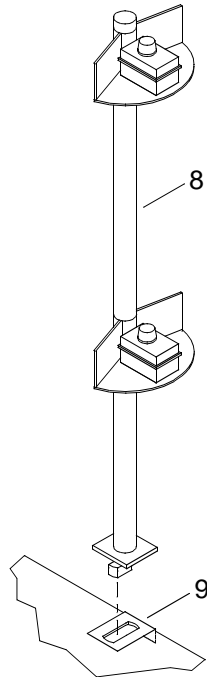
Battery platform must be flat in bottom of mast light case or light cover will not close.

- c. Position two batteries (1) on each side of conductor plate (6) in stub mast light case (2).
- d. Position battery bracket (5) over batteries (1) and conductor plate (6).
- e. Push battery bracket (5) down evenly over batteries (1).
- f. Position wire (7) away from edges of stub mast light case (2).
- g. Close light cover (3) and latch clasp (4).

WARNING

**HEAVY OBJECTS**

2. Using assistant, install stub mast (8).



- a. Position stub mast (8) at mounting location on aft starboard side of end rake ISO fitting (9).
- b. Insert base of the stub mast (8) into corner ISO fitting (9).
- c. Rotate stub mast (8) 90° to lock into ISO fitting (9) with stub mast (8) aimed aft.

END OF WORK PACKAGE

**OPERATOR MAINTENANCE
CAUSEWAY FERRY
BOW STUB MAST
OPERATION UNDER USUAL CONDITIONS**

INITIAL SETUP:**Tools**

Tool Kit, General Mechanic's (Rail and Marine) (Item 76, WP 0105 00)
 Gloves, Men's and Women's (Leather Palm) (Item 31, WP 0105 00)
 Goggles, Sun, Wind and Dust (Safety) (Item 34, WP 0105 00)
 Life Preserver, Vest (Item 45, WP 0105 00)
 Helmet, Safety (Brown) (Item 40, WP 0105 00)

Materials/Parts

Battery, Non-Rechargeable
 PN EV90
 (83740)
 Qty 2

Personnel Required

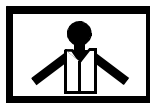
Seaman 88K (2)

Equipment Condition

Module ISOPAK Disassembled. (WP 0007 00)
 Operation Of Male And Female Guillotine Connectors. (WP 0008 00)
 D-Ring/Cloverleaf Fittings And Deck Cleat Fittings Installed. (WP 0009 00)
 Module String Assembled. (WP 0010 00)
 Causeway Ferry Powered Section Assembled On Deck Of Sealift Vessel. (WP 0013 00)
 Causeway Ferry Powered Section Assembled In Water. (WP 0013 10)
 Causeway Ferry Above Deck Equipment Installed. (WP 0014 00)
 Anchorboard Assembly Installed. (WP 0015 00)
 Stub Navigation Mast Installed. (WP 0016 00)

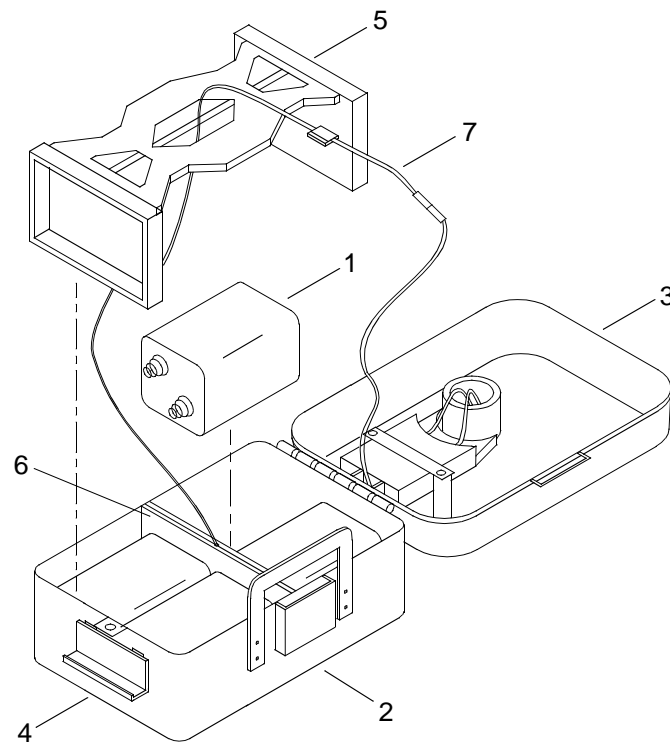
PREPARATION FOR USE - INSTALL BOW STUB MAST

WARNING

**VEST****HELMET PROTECTION****HEAVY PARTS****MOVING PARTS**

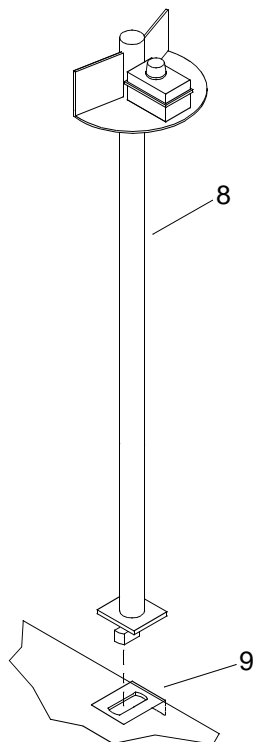
All personnel must wear personal flotation device, hard hat, safety shoes and gloves during CF operations and maintenance. Failure to observe these precautions could result in serious injury or death.

1. Install four batteries (1) into bow stub mast light (2).



- a. Open light cover (3) by unlatching clasp (4).
- b. Remove battery bracket (5).
- c. Remove conductor plate (6).
- d. Position two batteries (1) on each side of conductor plate (6) in bow stub mast light case (2).
- e. Install conductor plate (6).
- f. Install battery bracket (5).
- g. Position wire (10) away from edges of bow stub mast light case (5).
- h. Close light cover (6) and latch clasp (7).

2. Install bow stub mast (8).



WARNING



HEAVY OBJECTS

- a. Using an assistant, position bow stub mast (8) at ISO fitting (9) mounting location on forward starboard side of end rake.
- b. Insert base of the bow stub mast (8) into corner ISO fitting (9).
- c. Rotate bow stub mast (8) 90° to lock into ISO fitting (9) with bow stub mast (8) aimed forward.

END OF WORK PACKAGE

**OPERATOR MAINTENANCE
CAUSEWAY FERRY
MAIN MAST DECK FLOODLIGHT
OPERATION UNDER USUAL CONDITIONS**

INITIAL SETUP:**Tools**

Tool Kit, General Mechanic's (Rail and Marine) (Item 76, WP 0105 00)
Gloves, Men's and Women's (Leather Palm) (Item 31, WP 0105 00)
Goggles, Sun, Wind and Dust (Safety) (Item 34, WP 0105 00)
Life Preserver, Vest (Item 45, WP 0105 00)
Helmet, Safety (Brown) (Item 40, WP 0105 00)

Personnel Required

Seaman 88K

**PREPARATION FOR USE - INSTALLATION OF CAUSEWAY FERRY MAIN
MAST DECK FLOODLIGHT****INSTALL MAIN MAST DECK FLOODLIGHT****NOTE**

This task is typical for installation of both port and starboard deck floodlights

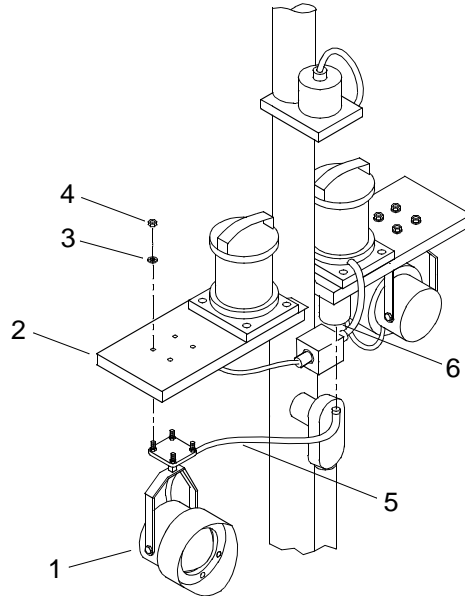
When installing main mast deck floodlights one shall be installed facing forward and the other facing aft.

1. Gain access to the top of the operators cab using steps on side of cab.

WARNING

**HEAVY OBJECTS**

2. Install main mast deck floodlight (1) on main mast mounting bracket (2).



- a. Position main mast deck floodlight (1) on main mast mounting bracket (2).
 - b. Install four washers (3) and nuts (4).
 - c. Tighten nuts (4).
3. Connect main mast deck floodlight electrical wire (5) to junction box (6).

END OF WORK PACKAGE

**OPERATOR MAINTENANCE
CAUSEWAY FERRY
FENDERS
OPERATION UNDER USUAL CONDITIONS**

INITIAL SETUP:**Tools**

Tool Kit, General Mechanic's (Rail and Marine) (Item 76, WP 0105 00)
 Gloves, Men's and Women's (Leather Palm) (Item 31, WP 0105 00)
 Goggles, Sun, Wind and Dust (Safety) (Item 34, WP 0105 00)
 Life Preserver, Vest (Item 45, WP 0105 00)
 Helmet, Safety (Brown) (Item 40, WP 0105 00)
 Sling, Lifting, 5,300 (Green) (Item 68, WP 0105 00)
 Qty 2
 2-Ton, ½ in. Anchor Shackle (Item 1, WP 0105 00)
 Qty 2
 Crowbar (Item 15, WP 0105 00)
 Hammer, Hand (10 lb Sledge) (Item 36, WP 0105 00)

Personnel Required

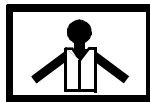
Seaman 88K (2)

Equipment Condition

Causeway Ferry Powered Section Assembled. (WP 0013 00, WP 0013 10)

PREPARATION FOR USE - INSTALLATION OF FENDERS

WARNING



VEST



HELMET PROTECTION



HEAVY PARTS



MOVING PARTS

All personnel must wear personal flotation device, hard hat, safety shoes and gloves during CF operations and maintenance. Failure to observe these precautions could result in serious injury or death.

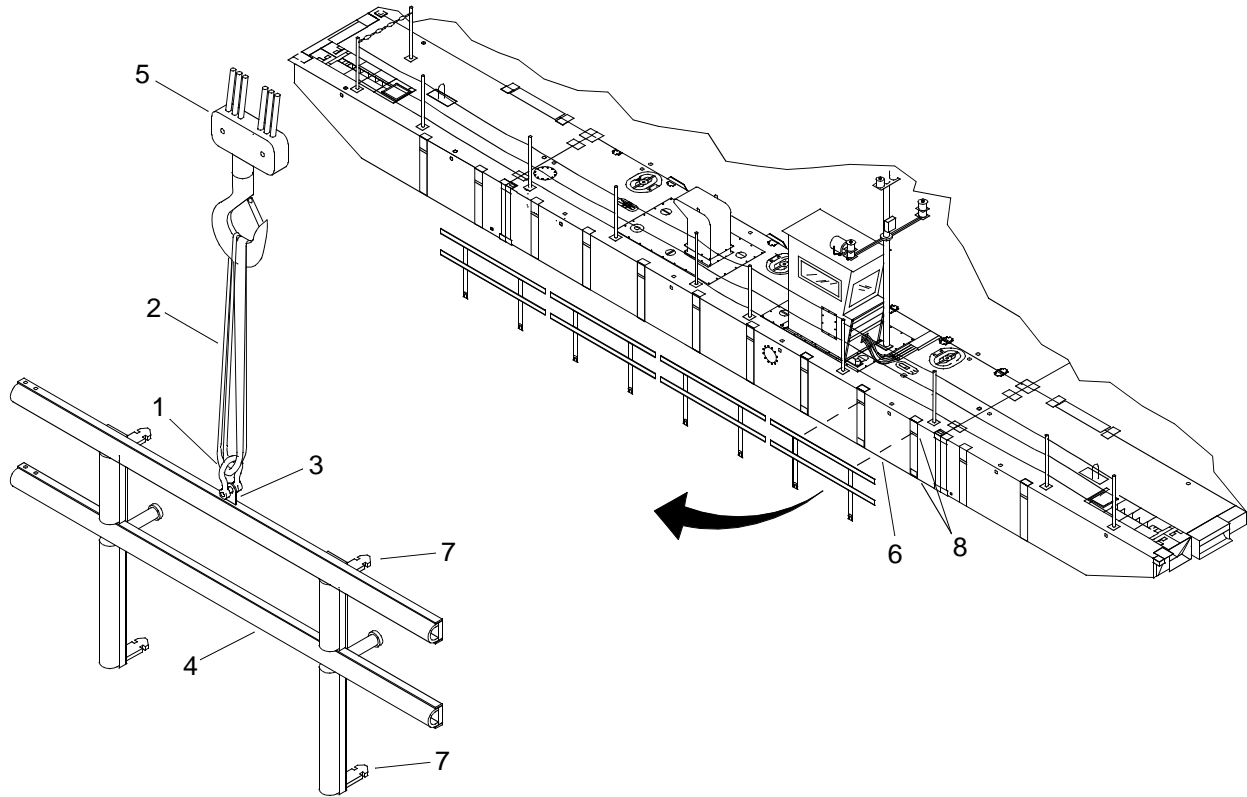
INSTALL PROPULSION MODULE SIDE FENDERS

NOTE

This procedure is typical for installation of side fenders on both port and starboard sides of powered section.

1. Remove all outboard guillotine connector male pins. (Contact unit maintenance.)
2. Raise all guillotines. (WP 0008 00)

3. Attach 2-ton shackle (1) and 5,300 lb sling (2) to lifting pad (3) of side fender (4).



4. Attach 5,300 lb sling (2) to crane (5).

WARNING



HEAVY PARTS

NOTE

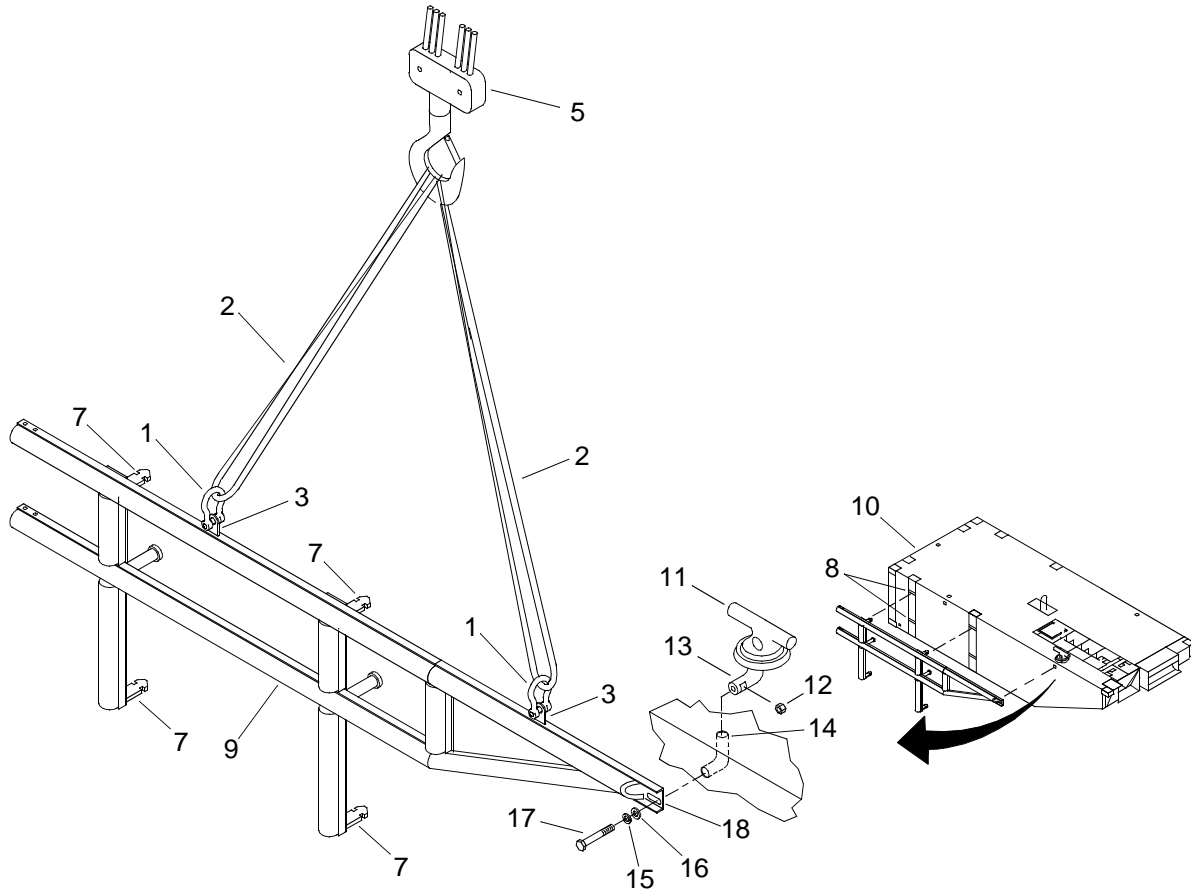
Side fender lower pins must be inserted into bottom connectors before top pins are inserted into top connectors.

5. Using crane and sling, position side fender (4) on side of power module (6) so pins (7) align with guillotine top and bottom connectors (8).
6. Lower guillotines. (WP 0008 00)
7. Remove shackle (1) and sling (2) from lifting pad (3).
8. Remove sling (2) from crane (5).
9. Repeat steps 2 through 8 for remaining side fender assemblies (4).

INSTALL END RAKE SIDE FENDERS**NOTE**

This procedure is typical for installation of end rake side fenders on both port and starboard sides of powered section.

1. Remove all outboard guillotine connector male pins. (Contact unit maintenance.)
2. Raise guillotines. (WP 0008 00)
3. Attach two 2-ton shackles (1) and two 5,300 lb slings (2) to lifting pad (3) of forward/aft side fender (9).

**WARNING****HEAVY PARTS**

4. Using crane and slings, position forward/aft side fenders (9), on side of end rake module (10), so pins (7) align with guillotine top and bottom connectors (8).
5. Lower guillotines. (WP 0008 00)
6. Connect forward/aft side fender (9), to side of end rake module (10), using deck cleat (11).

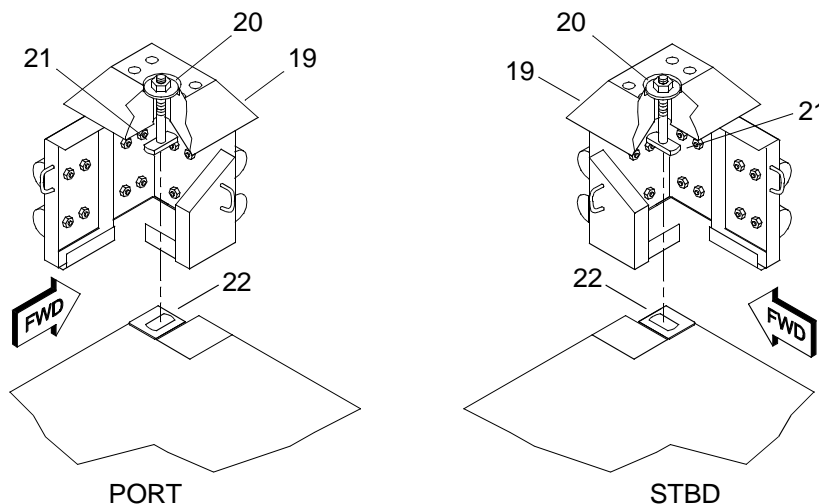
- a. Place nut (12) in slot in the tailpiece (13) of the deck cleat (11).
 - b. Insert deck cleat (11) into module turn tube (14).
 - c. Install lock washer (15) and flat washer (16) on bolt (17).
 - d. Install bolt (17) with washers (15 and 16) through hole (18) in forward/aft side fender and into tail piece (13). Tighten bolt (17).
7. Remove shackle (1) and sling (2) from lifting pad (3).
 8. Remove sling (2) from crane (5).

INSTALL CORNER FENDERS

NOTE

This procedure is typical for installation of the corner fenders on both port and starboard sides of powered section.

1. Attach tag lines to corner fenders (19) and secure on deck.
2. Install corner fenders (19).



- a. Loosen nut (20) on tee bolt (21), but do not remove.

WARNING



HEAVY OBJECTS

- b. Using an assistant, install corner fender (19) over ISO fitting (22) until tee bolt (21) enters slot in ISO fitting (22).

-
- c. Turn tee bolt (21) $\frac{1}{4}$ turn in ISO fitting (22).
 - d. Tighten nut (20).
3. Remove tag lines.

END OF WORK PACKAGE

**OPERATOR MAINTENANCE
CAUSEWAY FERRY
SAFETY EQUIPMENT
OPERATION UNDER USUAL CONDITIONS**

INITIAL SETUP:**Tools**

Tool Kit, General Mechanic's (Rail and Marine) (Item 76, WP 0105 00)
 Gloves, Men's and Women's (Leather Palm) (Item 31, WP 0105 00)
 Goggles, Sun, Wind and Dust (Safety) (Item 34, WP 0105 00)
 Life Preserver, Vest (Item 45, WP 0105 00)
 Helmet, Safety (Brown) (Item 40, WP 0105 00)

Personnel Required

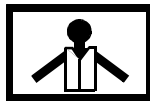
Seaman 88K

Equipment Condition

Module ISOPAK Disassembled. (WP 0007 00)
 Operation Of Male And Female Guillotine Connectors. (WP 0008 00)
 D-Ring/Cloverleaf Fittings And Deck Cleat Fittings Installed. (WP 0009 00)
 Module String Assembled. (WP 0010 00)
 Causeway Ferry Powered Section Assembled. (WP 0013 00, WP 0013 10)
 Causeway Ferry Above Deck Equipment Installed. (WP 0014 00)
 Anchorboard Assembly Installed. (WP 0015 00)
 Stub Navigation Mast Installed. (WP 0013 00)
 Bow Mast Installed. (WP 0016 10)
 Fenders Installed. (WP 0017 00)

PREPARATION FOR USE - INSTALLATION OF SAFETY EQUIPMENT**INSTALLATION OF STANCHIONS**

WARNING



VEST



HELMET PROTECTION



HEAVY PARTS



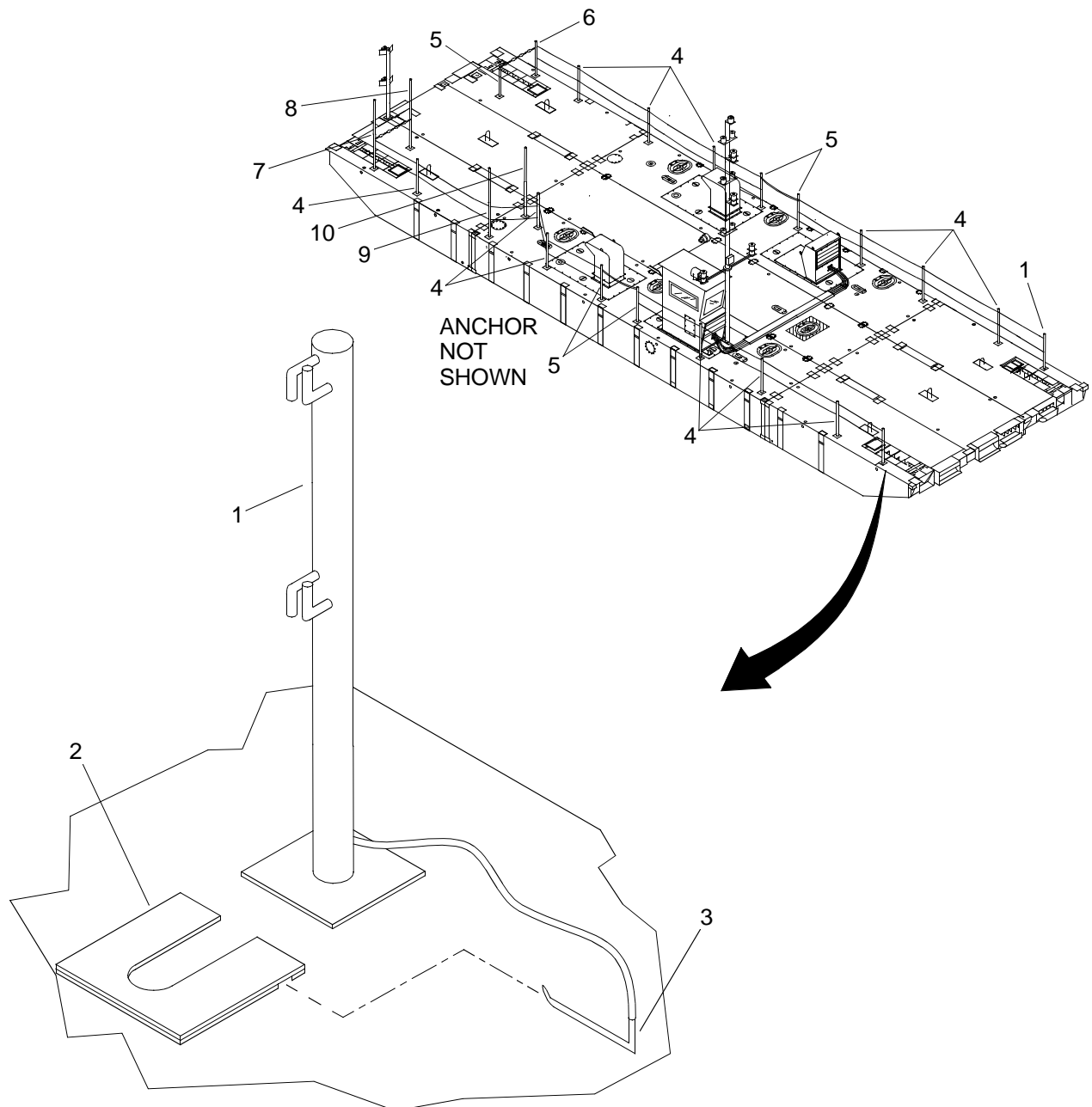
MOVING PARTS

All personnel must wear personal flotation device, hard hat, safety shoes and gloves during CF operations and maintenance. Failure to observe these precautions could result in serious injury or death.

NOTE

All safety equipment components are stored in the BII container.

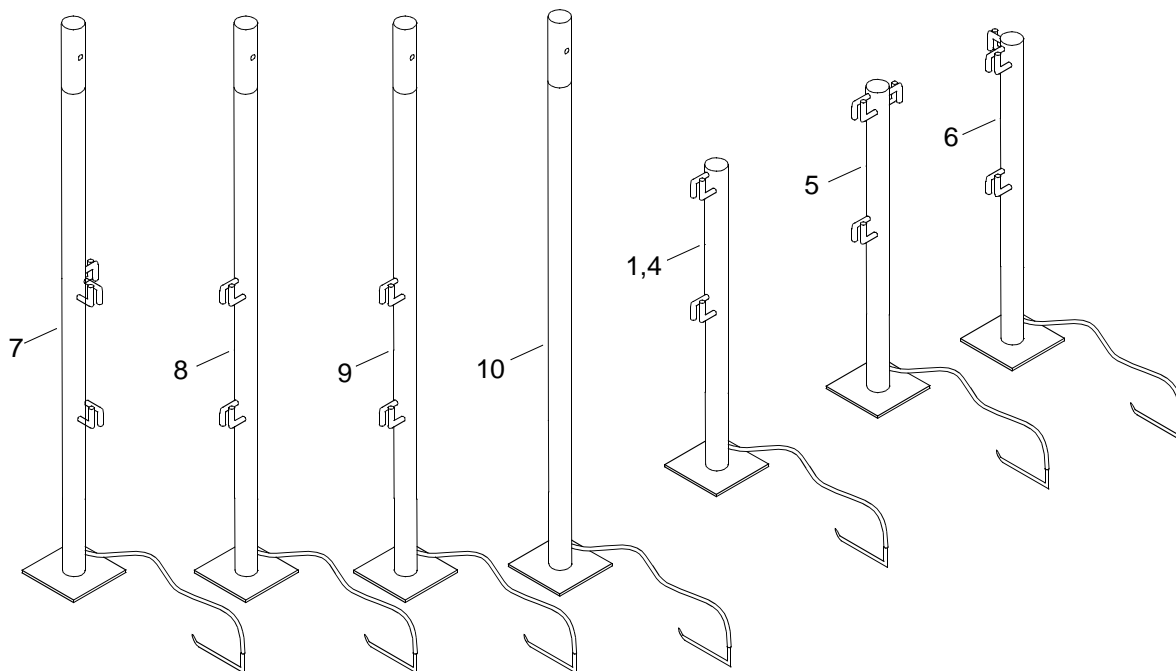
1. Install two forward end stanchions (1) into deck fittings (2) and secure with pins (3).



NOTE

One deck fitting for life line stanchion is located inboard of anchorboard assembly.

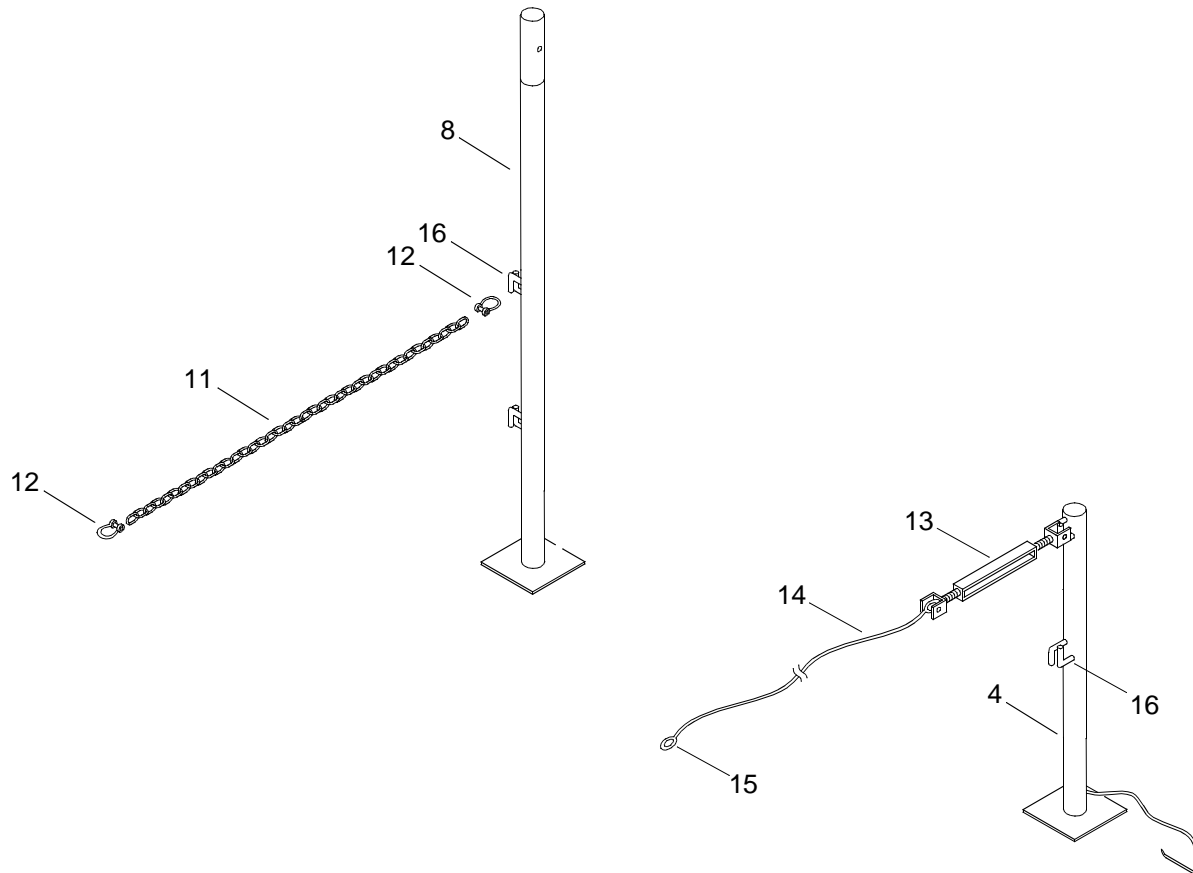
2. Install one inboard, starboard life line stanchion (4) in deck fitting (2). Secure with pin (3).
3. Install 11 side life line stanchions (4) into deck fittings (2) and secure with pins (3).



4. Install one inboard, aft end stanchion (5) and four center stanchions (5) into deck fitting (2) and secure with pins (3).
5. Install one aft corner stanchion (6) into deck fitting (2) and secure with pins (3).
6. Install one aft corner canopy stanchion (7) into deck fitting (2) and secure with pins (3).
7. Install one inboard, aft end canopy stanchion (8) into deck fitting (2) and secure with pins (3).
8. Install one outboard canopy stanchion (9) into deck fitting (2) and secure with pins (3).
9. Install one inboard, canopy stanchion (10) into deck fitting (2) and secure with pins (3).

CENTER STANCHION CHAINS AND AFT END CHAINS INSTALLATION

1. Lay all chains (11) out on deck.
2. Install shackles (12) on chains (11).

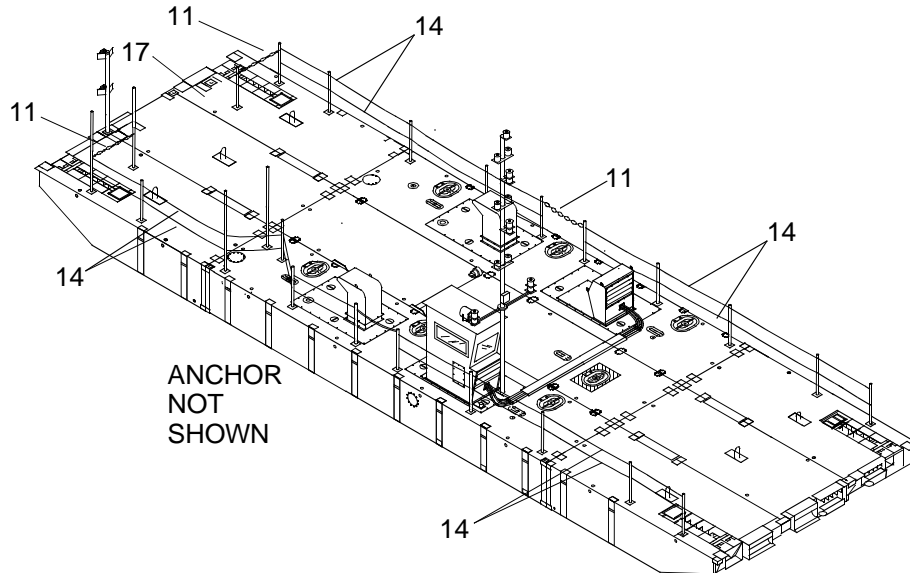


3. Connect aft end chain (11) to aft end stanchion (5) and aft corner stanchion (6) with shackles (12).
4. Connect aft end chain (11) to corner canopy stanchion (7) and aft canopy stanchion (8) with shackles (12).
5. Using shackles (12), connect center stanchion chains (11) between port and starboard center stanchions (5).

PORT SIDE LIFELINE INSTALLATION

1. Lay all lifelines out on deck.
2. Connect turnbuckles (13) to side lifelines (14).

3. Connect two side lifelines (14) to forward stanchion (1) with turnbuckles (13).



4. Connect side lifelines (14) to forward center stanchion (5) by positioning lifeline ends (15) over cable guides (16).
5. Connect side lifelines (14) to aft center stanchion (5) by positioning lifeline ends (15) over cable guides (16).
6. Connect side lifelines (14) to aft port corner stanchion (6) with turnbuckles (13).
7. Position side lifelines (14) between cable guides (16) of port side stanchions (4).
8. Tighten turnbuckles (13) to take up slack in side lifelines (14).

STARBOARD SIDE LIFE LINE INSTALLATION

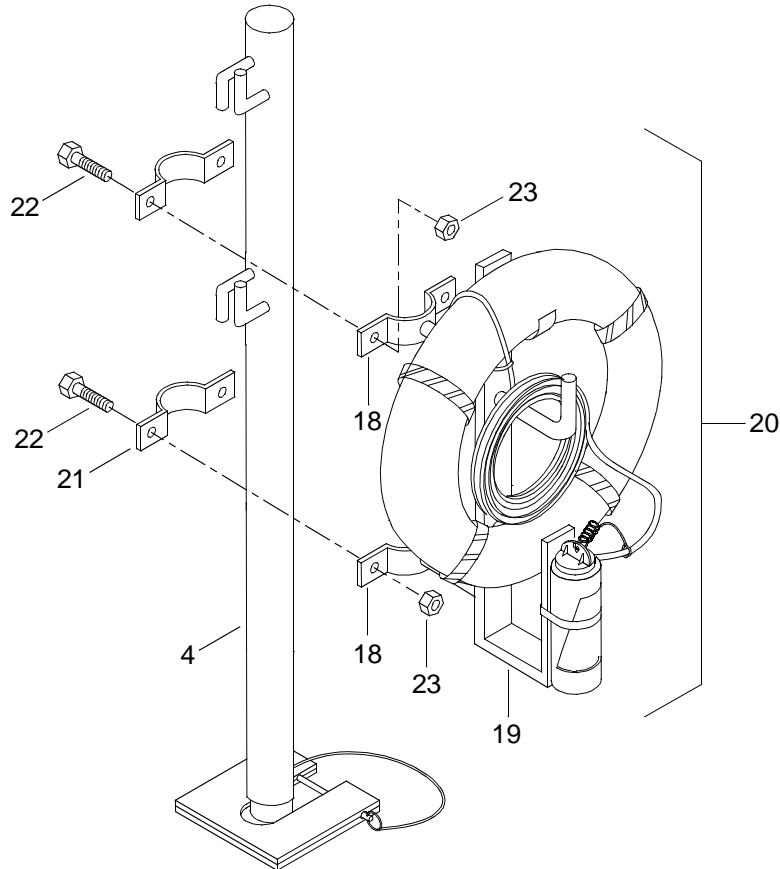
1. Connect side lifelines (14) to forward starboard stanchion (1) with turnbuckles (13).
2. Connect side lifelines (14) to forward center stanchion (5) by positioning lifeline ends (15) over cable guides (16).
3. Connect shortest side lifelines (14) to aft center stanchion (5) by positioning lifeline end (15) over cable guides (16).
4. Connect side lifelines (14) to aft corner canopy stanchion (7) with turnbuckles (13).
5. Connect starboard aft lifelines (14) and shortest side lifelines (14) together with turnbuckles (13).
6. Position side lifelines (14) between cable guides (16) of starboard side stanchions (4) and canopy stanchion (9).
7. Install shackles (12) on ends of aft end lifeline (17).
8. Connect aft end lifeline (17) to aft canopy stanchion (8) and aft end stanchion (5) by connecting shackles (12) to cable guides (16).
9. Tighten turnbuckles (13) to take up slack in side lifelines (14).

LIFE RING ASSEMBLY INSTALLATION**NOTE**

Life ring assemblies are mounted facing outboard on forward starboard and aft port side of the CF.

These steps are typical for the installation of life ring assemblies.

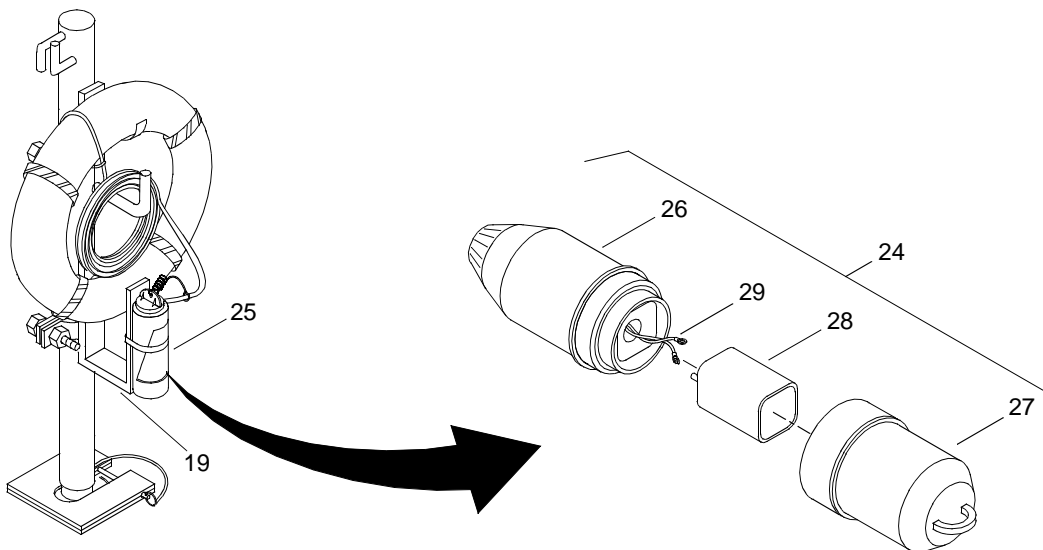
1. Position inner clamps (18) on bracket (19) of life ring assembly (20) on side stanchion (4).



2. Install outer clamps (21), bolts (22) and nuts (23) on side stanchion (4) and inner clamps (18). Tighten nuts (23).

LIFE RING STROBE LIGHT BATTERY INSTALLATION

1. Remove strobe light assembly (24) from strobe light holder (25) on bracket (19).

**NOTE**

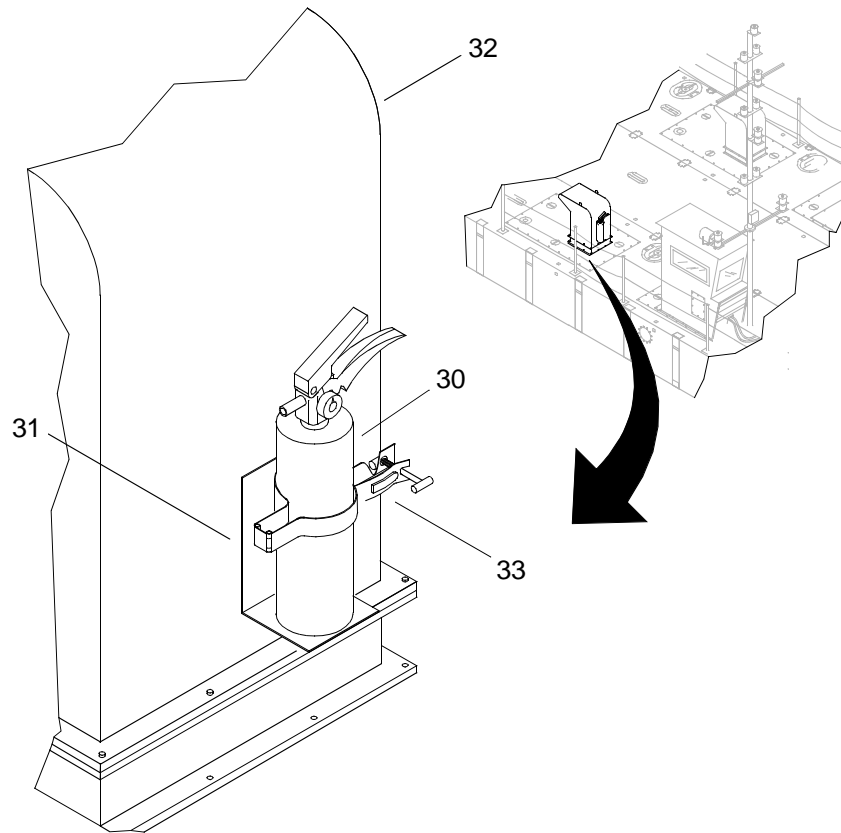
Strobe light batteries are stowed in the BII container.

These steps are typical for the installation of strobe light batteries.

1. Unscrew strobe light housing (26) from strobe light base (27).
2. Position battery (28) in strobe light base (27).
3. Connect two battery wires (29) to battery (28).
4. Screw strobe light housing (26) and strobe light base (27) together.
5. Install strobe light assembly (24) in strobe light holder (25).

PORTABLE FIRE EXTINGUISHER INSTALLATION

1. Position portable CO2 fire extinguisher (30) on bracket (31) on exhaust plenum (32) located aft of operators cab.



2. Secure portable CO2 fire extinguisher (30) to bracket (31) by closing and latching clamp (33).

END OF WORK PACKAGE

**OPERATOR MAINTENANCE
CAUSEWAY FERRY
OPERATION UNDER USUAL CONDITIONS**

INITIAL SETUP:**Tools**

Gloves, Men's and Women's (Leather Palm) (Item 31, WP 0105 00)
Goggles, Sun, Wind and Dust (Safety) (Item 34, WP 0105 00)
Life Preserver, Vest (Item 45, WP 0105 00)
Helmet, Safety (Brown) (Item 40, WP 0105 00)
Crowbar (Item 15, WP 0105 00)
Hammer, Hand (10 lb Sledge) (Item 36, WP 0105 00)

Personnel Required

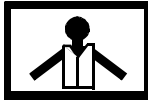
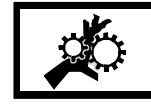
Seaman 88K

Equipment Condition

Module ISOPAK Disassembled. (WP 0007 00)
Operation Of Male And Female Guillotine Connectors. (WP 0008 00)
D-Ring/Cloverleaf Fittings And Deck Cleat Fittings Installed. (WP 0009 00)
Module String Assembled. (WP 0010 00)
Causeway Ferry Powered Section Assembled. (WP 0013 00)
Causeway Ferry Above Deck Equipment Installed. (WP 0014 00)
Anchorboard Assembly Installed. (WP 0015 00)
Stub Navigation Mast Installed. (WP 0016 00)
Fenders Installed. (WP 0017 00)
Safety Equipment Installed. (WP 0018 00)

PREPARATION FOR USE - ASSEMBLY OF CAUSEWAY FERRY**ASSEMBLE CAUSEWAY FERRY**

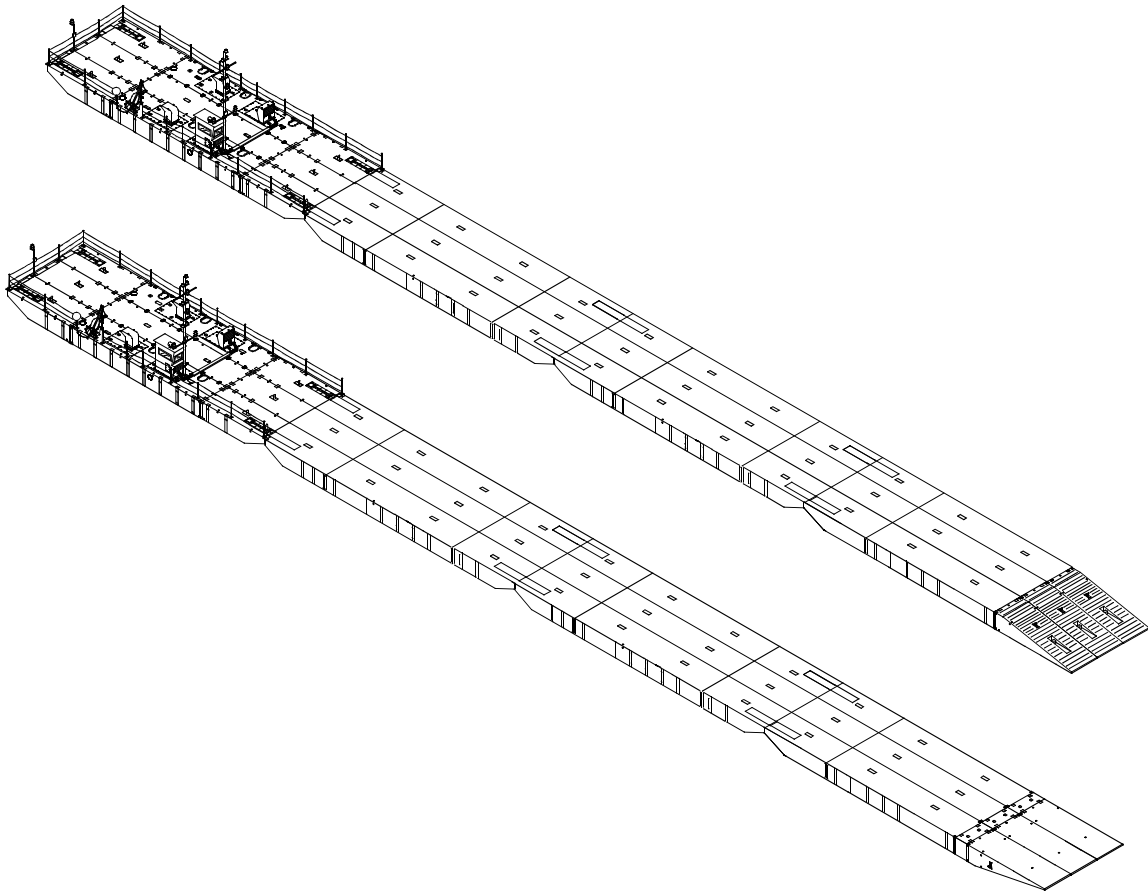
WARNING

**VEST****HELMET PROTECTION****HEAVY PARTS****MOVING PARTS**

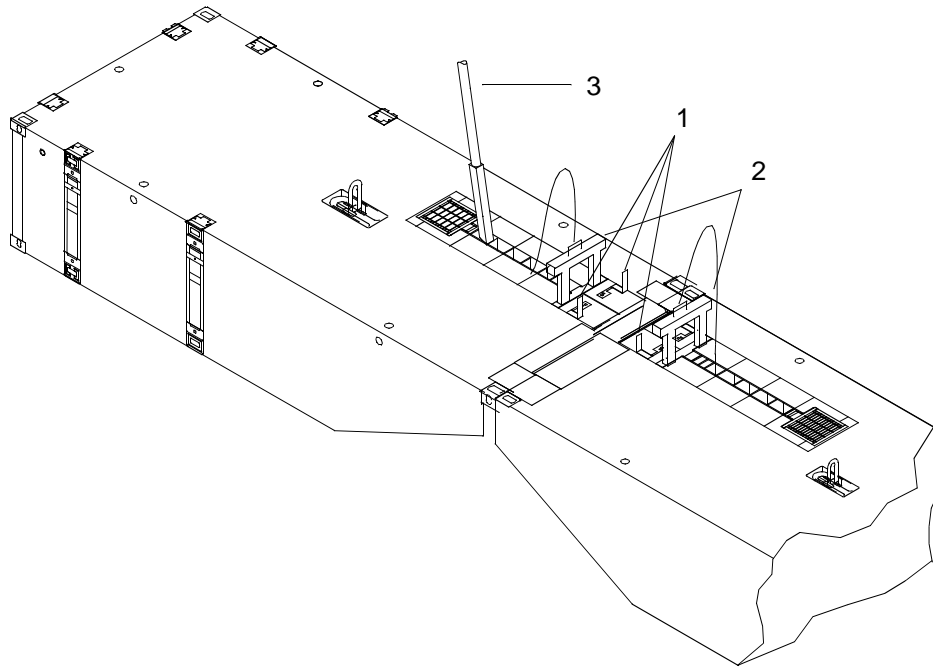
All personnel must wear a personal flotation device, hard hat, safety shoes and gloves during CF operations and maintenance. Failure to observe these precautions could result in serious injury or death to personnel.

NOTE

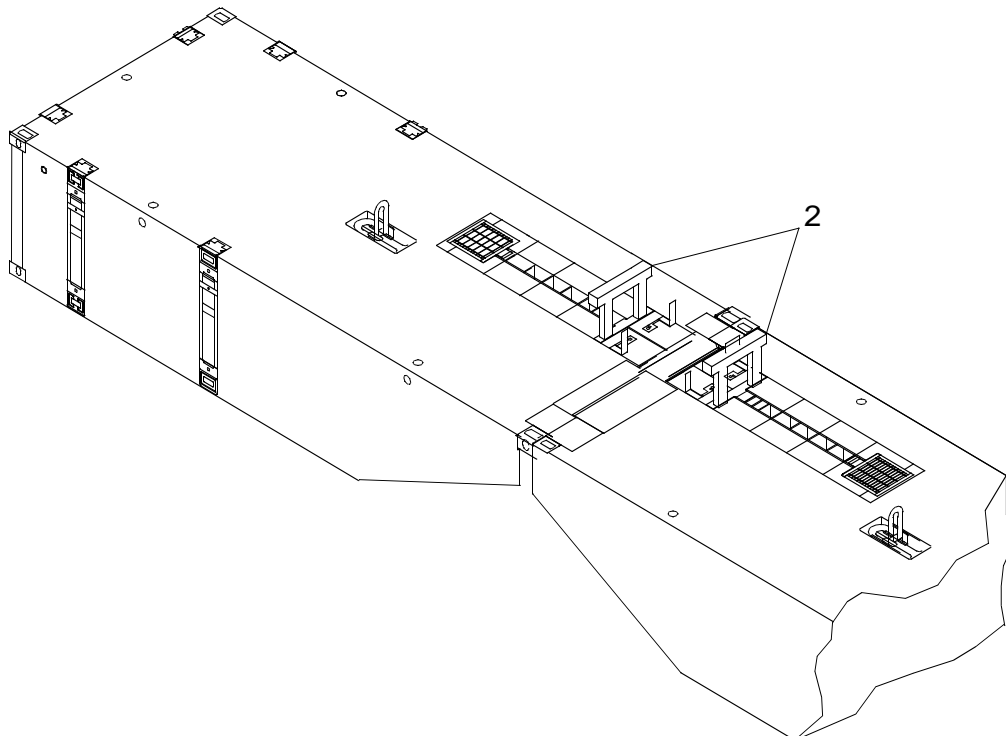
Causeway sections are off-loaded and assembled into causeway rafts. Causeway ferry sections are assembled by bringing the connecting ends together using the warping tug. While the warping tug holds the sections together, comealongs and crowbars may be required for final alignment of sections.

**CF (FULL ARRANGEMENT)**

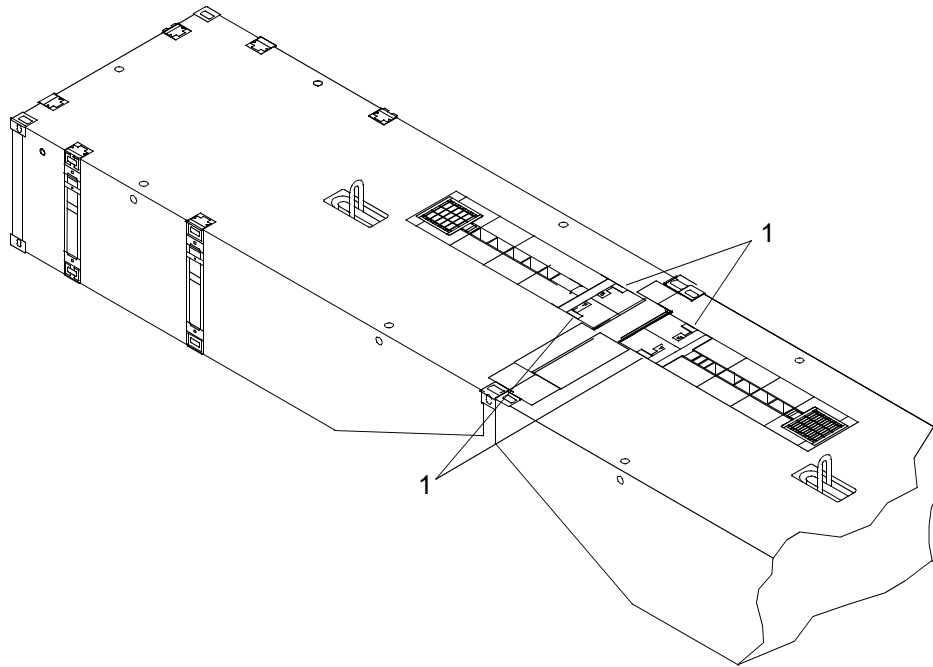
1. Maneuver sections together using warping tugs, ropes/lines, flush turn tubes and lift lugs so that the tapered surfaces of male and female shear connectors mate together in general alignment.



2. Rotate chute bolt handles (1) and pull the chute bolts (1) to the unlocked position.
3. Remove guillotines (2).
4. Push each flexor connector from the left end rake into the corresponding pocket of the right end rake until the guillotines (2) are aligned with the flexor connector slots.
5. Use a crowbar (3) to position flexor connector.
6. Insert guillotines (2) into flexor slots.



7. Drive guillotines (2) down into flexor slots. Use a sledgehammer.
8. Push the chute bolts (1) to the locked position and rotate the chute bolt handles (1) to the closed position.



END OF WORK PACKAGE

**OPERATOR MAINTENANCE
CAUSEWAY FERRY
DECK BOX
OPERATION UNDER USUAL CONDITIONS**

INITIAL SETUP:**Tools**

Tool Kit, General Mechanic's (Rail and Marine) (Item 76, WP 0105 00)
 Gloves, Men's and Women's (Leather Palm) (Item 31, WP 0105 00)
 Goggles, Sun, Wind and Dust (Safety) (Item 34, WP 0105 00)
 Life Preserver, Vest (Item 45, WP 0105 00)
 Helmet, Safety (Brown) (Item 40, WP 0105 00)
 Sling, Lifting, 5,300 lb (Green) (Item 70, WP 0105 00)
 Qty 2
 4 ¾ Ton ¾ in. Shackle (Item 5, WP 0105 00)
 Qty 2

Personnel Required

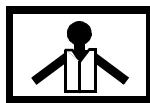
Seaman 88K

Equipment Condition

Module ISOPAK Disassembled. (WP 0007 00)
 Operation Of Male And Female Guillotine Connectors. (WP 0008 00)
 D-Ring/Cloverleaf Fittings And Deck Cleat Fittings Installed. (WP 0009 00)
 Module String Assembled. (WP 0010 00)
 Causeway Ferry Powered Section Assembled. (WP 0013 00, WP 0013 10)
 Causeway Ferry Above Deck Equipment Installed. (WP 0014 00)
 Anchorboard Assembly Installed. (WP 0015 00)
 Stub Navigation Mast Installed. (WP 0016 00)
 Bow Mast Installed. (WP 0016 10)
 Fenders Installed. (WP 0017 00)
 Safety Equipment Installed. (WP 0018 00)

PREPARATION FOR USE - INSTALLATION OF DECK BOX

WARNING



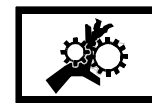
VEST



HELMET PROTECTION



HEAVY PARTS



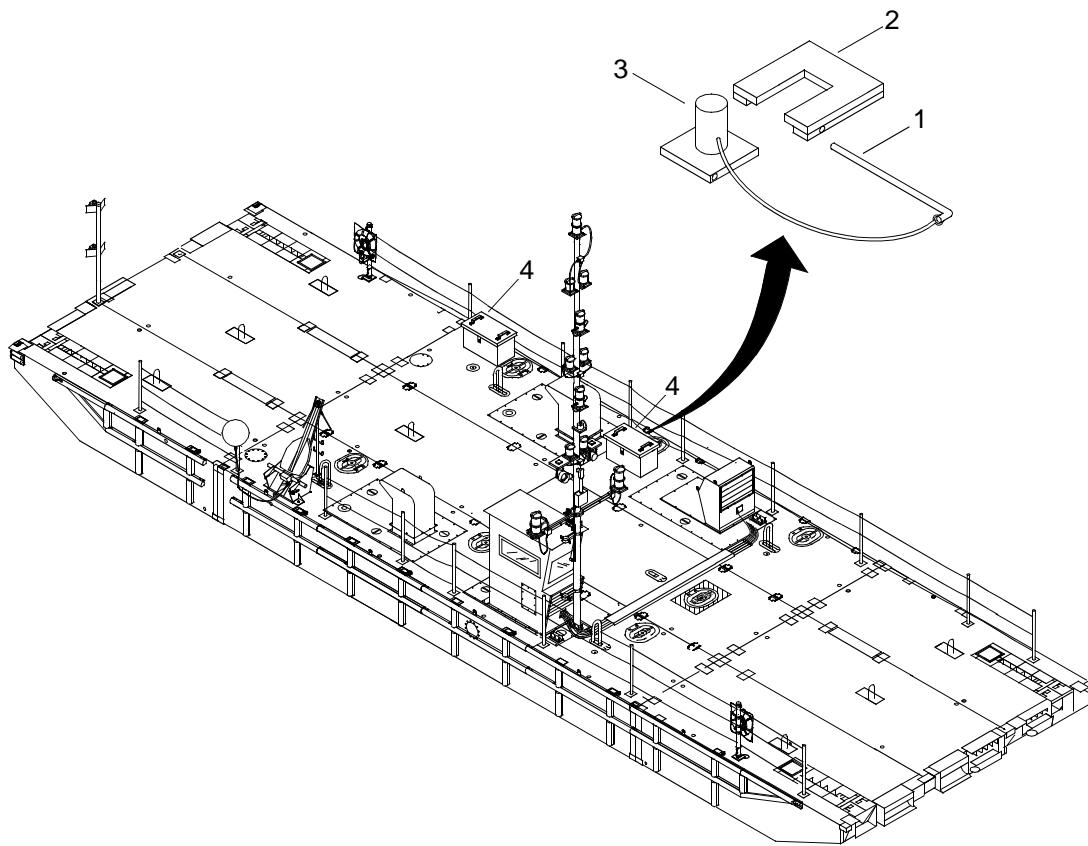
MOVING PARTS

All personnel must wear personal flotation device, hard hat, safety shoes and gloves during CF operations and maintenance. Failure to observe these precautions could result in serious injury or death.

NOTE

This task is typical for installation of both fore and aft deck boxes.

- Using crane, slings and shackles, position deck box (1) on deck of warping tug so deck box feet (2) are in front of stanchion clips (3).



WARNING

**HEAVY PARTS**

2. Using crane, slings and shackles, slide deck box (1) in stanchion clips (3).
3. Remove slings and shackles from deck box (1).
4. Install pins (4) in stanchion clips (3).

END OF WORK PACKAGE

**OPERATOR MAINTENANCE
CAUSEWAY FERRY
CREW SHELTER
OPERATION UNDER USUAL CONDITIONS**

INITIAL SETUP:**Tools**

Tool Kit, General Mechanic's (Rail and Marine) (Item 76, WP 0105 00)
 Gloves, Men's and Women's (Leather Palm) (Item 31, WP 0105 00)
 Goggles, Sun, Wind and Dust (Safety) (Item 34, WP 0105 00)
 Life Preserver, Vest (Item 45, WP 0105 00)
 Helmet, Safety (Brown) (Item 40, WP 0105 00)

Materials/Parts

Rope, Fibrous (Item 60, WP 0105 00)

Personnel Required

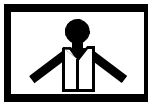
Seaman 88K (2)

Equipment Condition

Module ISOPAK Disassembled. (WP 0007 00)
 Operation Of Male And Female Guillotine Connectors. (WP 0008 00)
 D-Ring/Cloverleaf Fittings And Deck Cleat Fittings Installed. (WP 0009 00)
 Module String Assembled. (WP 0010 00)
 Causeway Ferry Powered Section Assembled. (WP 0013 00, WP 0013 10)
 Causeway Ferry Above Deck Equipment Installed. (WP 0014 00)
 Anchorboard Assembly Installed. (WP 0015 00)
 Stub Navigation Mast Installed. (WP 0016 00)
 Bow Mast Installed. (WP 0016 10)
 Fenders Installed. (WP 0017 00)
 Safety Equipment Installed. (WP 0018 00)

PREPARATION FOR USE - INSTALL CREW SHELTER

WARNING



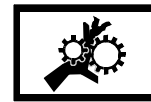
VEST



HELMET PROTECTION



HEAVY PARTS



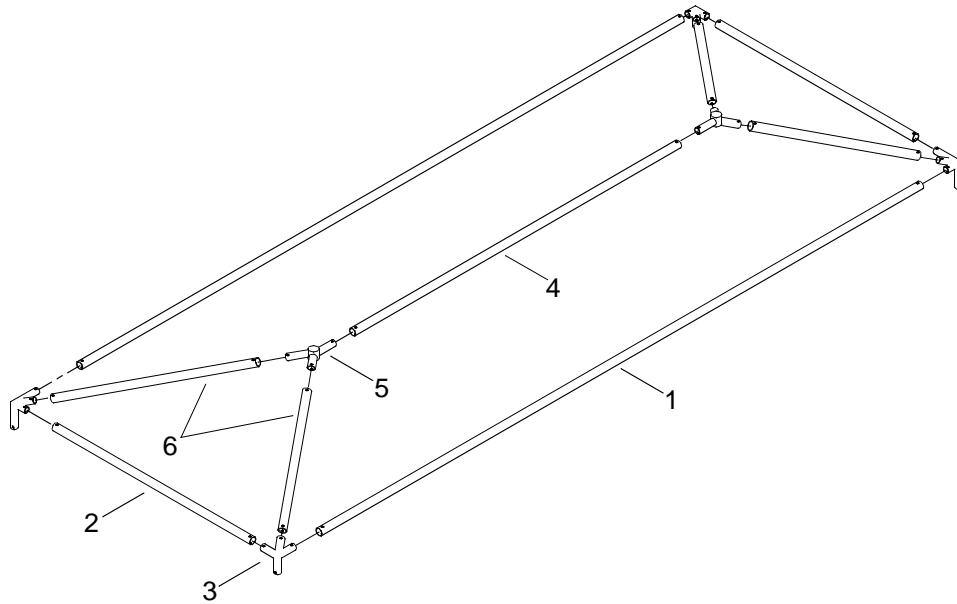
MOVING PARTS

All personnel must wear personal flotation device, hard hat, safety shoes and gloves during CF operations and maintenance. Failure to observe these precautions could result in serious injury or death.

NOTE

Assembly of the crew shelter canopy should be performed on deck of the CF and then placed onto deck stanchions.

1. Remove crew shelter canopy, hardware and aluminum pipes from BII container.

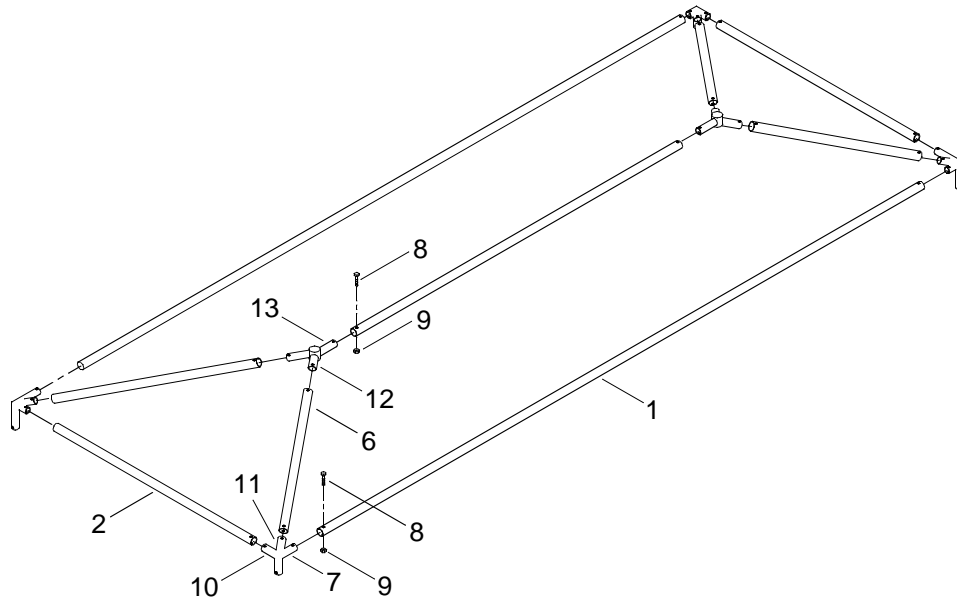


2. Position side aluminum pipes (1) on deck of CF approximately five feet apart.
3. Position end aluminum pipes (2) at ends of side aluminum pipes (1).
4. Position corner fittings (3) between aluminum pipes (1 and 2).
5. Position center aluminum pipe (4) in center of side aluminum pipes (1) and end aluminum pipes (2).
6. Position center Y-fittings (5) at ends of center aluminum pipe (4).
7. Position diagonal aluminum pipes (6) at ends of center Y-fittings (5) and corner fittings (3).

NOTE

The following steps are typical for the installation of corner fittings.

8. Install side aluminum pipe (1) into corner fitting leg (7).



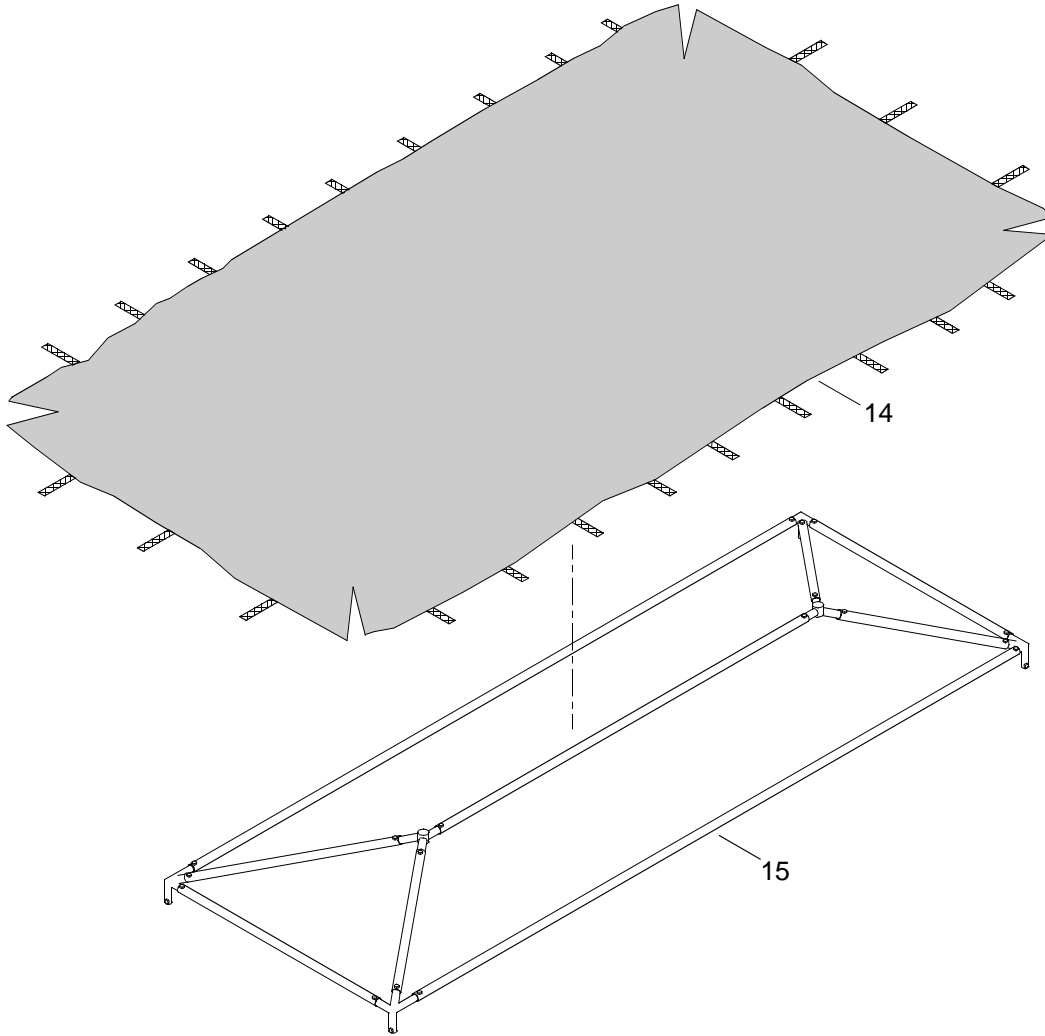
9. Install carriage bolt (8) through corner fitting leg (7).
10. Install hex head nut (9) on carriage bolt (8) and tighten.
11. Install end aluminum pipe (2) into corner fitting leg (10).
12. Install carriage bolt (8) through corner fitting leg (10).
13. Install hex head nut (9) on carriage bolt (8) and tighten.
14. Install diagonal aluminum pipe (6) into corner fitting leg (11).
15. Install carriage bolt (8) through corner fitting leg (11).
16. Install hex head nut (9) on carriage bolt (8).

NOTE

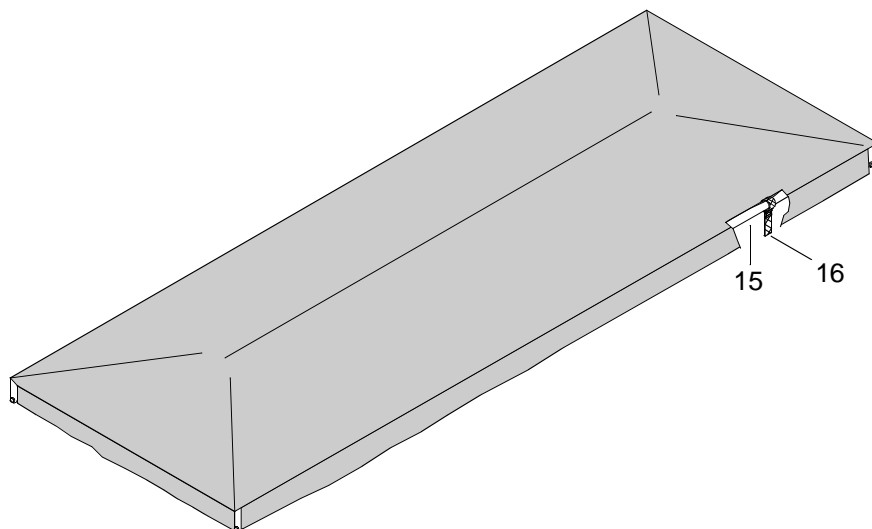
The following steps are typical for the installation of Y-fittings legs onto Y-fittings.

17. Install diagonal aluminum pipes (6) into Y-fitting legs (12) of Y-fitting (5).
18. Install carriage bolt (8) through Y-fitting leg (12) of Y-fitting (5).
19. Install hex head nut (9) onto carriage bolt (8) and tighten.
20. Install center aluminum pipe (4) into Y-fitting leg (13).
21. Install carriage bolt (8) through Y-fitting leg (13) of Y-fitting (5).
22. Install hex head nut (9) onto carriage bolt (8) and tighten.

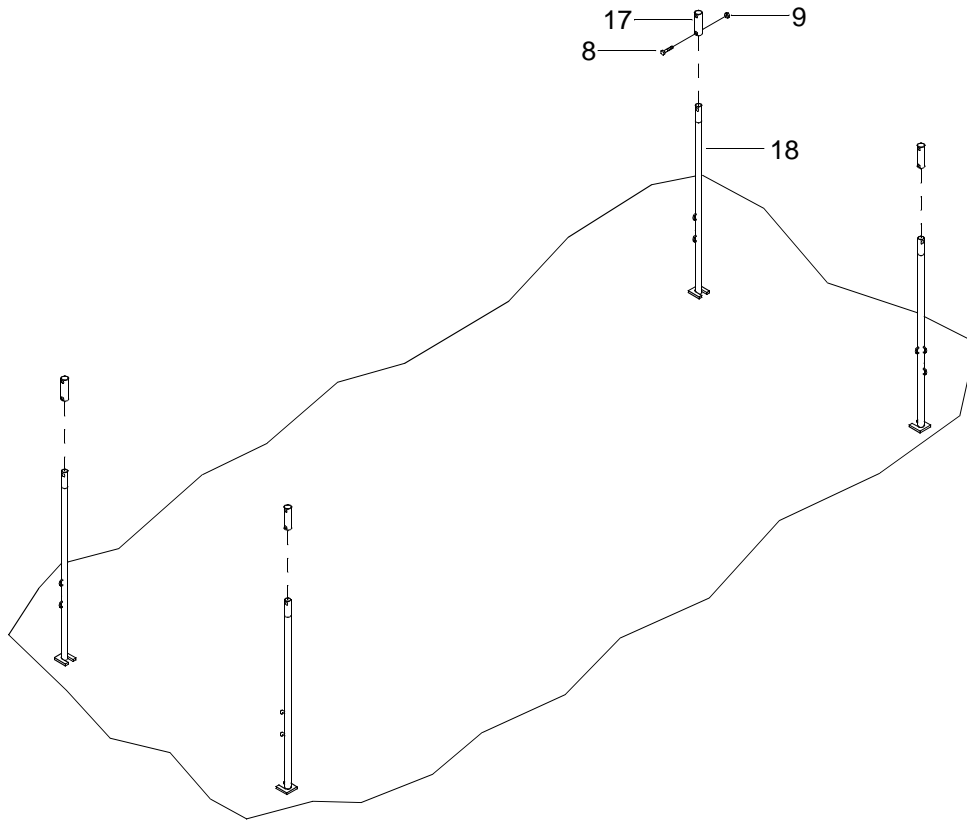
23. Using assistant, lay canopy cover (14) over the top of crew shelter frame (15).



24. Attach tiedown straps (16) to crew shelter frame (15).



25. Install aluminum pipe legs (17) onto stanchions (18).



26. Install carriage bolt (8) through aluminum pipe legs (17) and stanchions (18).

27. Install hex head nut (9) onto carriage bolt (8) and tighten.

WARNING

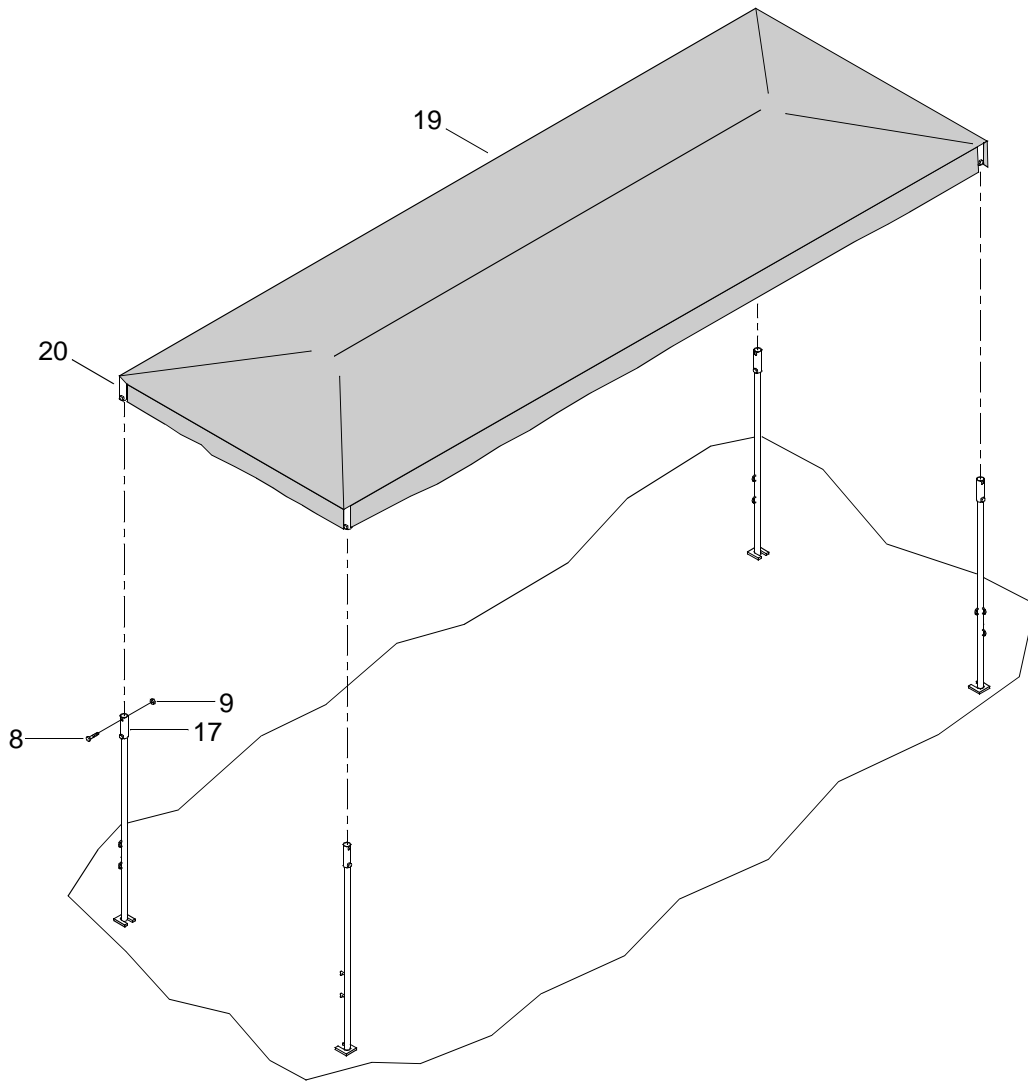


HEAVY OBJECTS

NOTE

The following steps are typical for installation of the corner connection legs onto the aluminum pipe legs.

28. Using assistant, install crew shelter assembly (19) onto aluminum pipe legs (17).



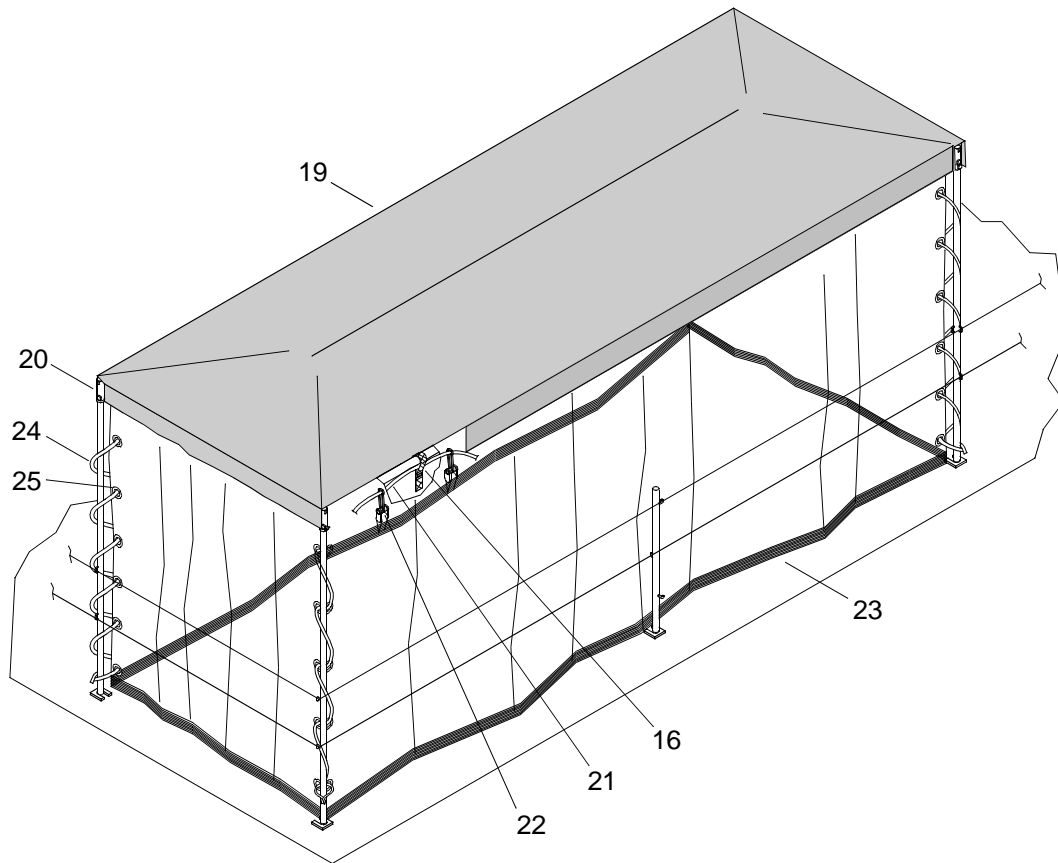
29. Install carriage bolt (8) through aluminum pipe leg (17) and corner connection leg (20).

30. Install hex head nut (9) on carriage bolt (8) and tighten.

NOTE

The following steps are typical for installation of the side panels.

31. Thread line (21) through tiedown straps (16) on crew shelter canopy (14).

**NOTE**

The panels when installed will be located inside of the stanchions.

Velcro is used to fasten the panels together at each corner of the crew shelter.

32. Attach snap hooks (22) of panels (23) to line (21).
33. Fasten panels (23) together.
34. Thread line (24) through grommets (25), around stanchions (18) and tie off.

END OF WORK PACKAGE

**OPERATOR MAINTENANCE
CAUSEWAY FERRY
OPERATING PROCEDURES
OPERATION UNDER USUAL CONDITIONS**

INITIAL SETUP:

Personnel Required

Seaman 88K
Engineer 88L

OPERATING PROCEDURES - CAUSEWAY FERRY

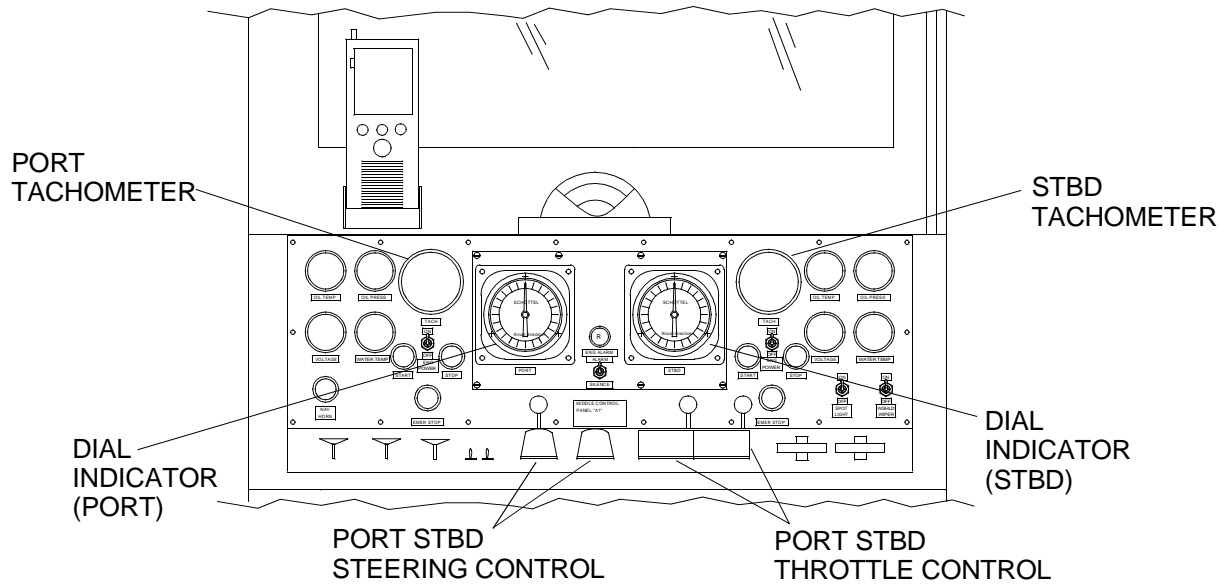
CONDUCT STARTING CHECKS IN THE CF OPERATOR CHECKLIST

■ **Table 1. CF Operator Starting Checklist.**

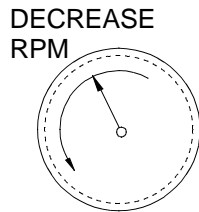
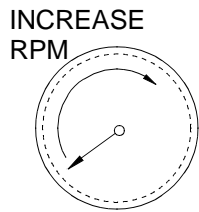
ITEM NO.	PROCEDURE	INITIAL WHEN COMPLETED
1	Verify the MAIN circuit breaker switches on the Port and Stbd Propulsion Module Circuit Breaker Panels (A6) are in the up (ON) position. Verify all circuit breaker switches except the ENGINE circuit breaker switch are in the up (ON) position.	
2	Turn on the propulsion module vent fan (Port and Stbd). Wait five minutes to clear engine room of fumes.	
3	Turn off the propulsion module vent fan (Port and Stbd).	
4	Position 50A disconnect circuit breaker to ON (closed) position (Port and Stbd).	
5	Position battery selector switch to ON (closed) (Port and Stbd).	
6	Perform before operation PMCS.	
7	Verify that fire suppression systems are in working order.	
8	Verify that bilge pump oily waste 3-way ball valves are in line for the oil waste containment system (Port and Stbd).	
9	Ensure that emergency air shutoff, located on the blower inlet, is set Port and Stbd. Reset if necessary.	
10	Place the ENGINE circuit breaker switch on the Port and Stbd Propulsion Module Circuit Breaker Panels (A6) in the up (ON) position. Ensure that no personnel are below deck before starting the engines.	
11	Verify that exhaust flappers are unlatched (Port and Stbd).	
12	Ensure that all ventilation doors are locked in the open position (Port and Stbd).	
13	Verify ENG ALARM toggle switches are set to ALARM (Port and Stbd).	
14	Verify FIRE warning alarm toggle switches are set to ALARM (Port and Stbd).	
15	Verify FLOODING warning alarm toggle switch is set to ALARM.	
16	Switch ENG POWER toggle switches to the ON position (Port and Stbd).	

■ **Table 1. CF Operator Starting Checklist. (Continued)**

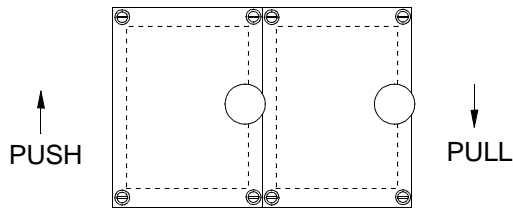
ITEM NO.	PROCEDURE	INITIAL WHEN COMPLETED	
17	Verify that the THROTTLE CONTROL levers are in the idle (all the way back) position (Port and Stbd).		
18	Verify that the CLUTCH control switches are in the DISENGAGED position (Port and Stbd).		
19	Depress Port and Stbd engine START buttons separately to start engines. Release push buttons as soon as engines start.		
20	Run engines at 800 RPM, without a load, for approximately five minutes while monitoring gauges.		
21	Observe engine oil pressure (40 - 70 PSI normal operating or 32 PSI minimum).		
22	Observe engine oil temperature is 215 - 230°F.		
23	Observe engine water temperature after warm up is 170 - 185°F.		
24	Ensure engine startup time is entered in engine log.		
25	Observe that tachometer is functioning.		
26	Observe that ammeter is functioning.		
27	Verify water is coming out of exhaust and discharge ports.		
28	Listen for any unusual noises and look for unusual smoke.		
29	Test cab heater fan for operation.		
30	Test defroster for operation.		
31	Return engines to idle and recheck transmission oil level. Oil level should register full on dipstick (Port and Stbd).		
32	Operate STEERING CONTROL levers and observe Port and Stbd steering indicators. Observe water jet wake relationship to steering indicator positions.		
33	Engage clutch controls (Port and Stbd).		
34	Disengage clutch controls (Port and Stbd).		
35	Ensure all hatches and deck equipment are secured for sea.		
NAME and RANK (Print)		SIGNATURE:	DATE:
CHIEF ENGINEER NAME and RANK (Print)		SIGNATURE:	DATE:
VESSEL MASTER NAME and RANK (Print)		SIGNATURE:	DATE:



TACHOMETERS



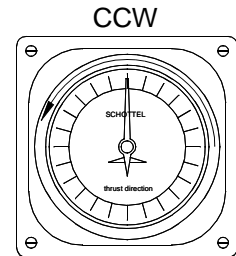
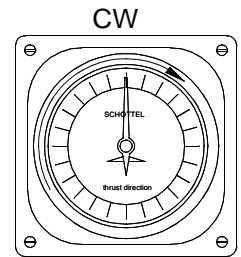
THROTTLE CONTROLS



STEERING CONTROL LEVERS



DIAL INDICATORS

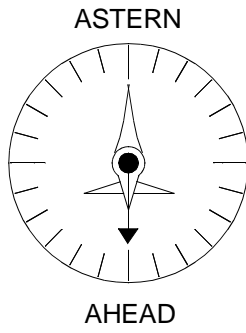
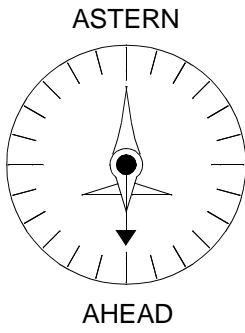


NOTE

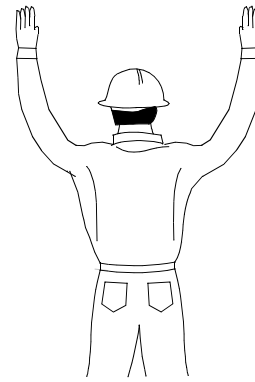
When the CF is comprised of one propulsion module powered by a 92 Series engine and one propulsion module powered by a 60 Series engine, pump-jet thrust will vary. The throttle controls must be carefully operated to keep both engines RPM equal.

If a propulsion module powered by a 92 Series engine is replaced by a propulsion module powered by a 60 Series engine, it will be required to reset the steering indicator to match the replacement propulsion module. Contact unit maintenance.

1. Engage clutches.
 - a. Push the clutch toggle switches forward to move forward.
 - b. Center the clutch toggle switches to return to neutral.
 - c. Pull the clutch toggle switches aft backflush.
2. To move the CF, push throttle control levers for the port and starboard propulsion modules forward to increase engine RPM.
3. Pulling throttle control levers back towards the operator will decrease the engine RPM.
4. Position steering nozzles to desired direction of thrust using port and stbd steering control joystick levers.
 - a. If the dial indicators are pointing forward, the causeway ferry will move forward.
 - b. If the dial indicators are pointing aft, the causeway ferry will move aft.
 - c. Push the control levers forward to rotate the steering nozzle in counterclockwise direction to move the causeway ferry to the right.
 - d. Pull the control levers aft to rotate the steering nozzle in a clockwise direction to move the causeway ferry to the left.
5. Perform during operation PMCS. (WP 0100 00)
6. Use hand signals to communicate instructions to the pilot of the causeway ferry.

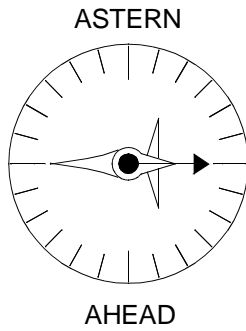
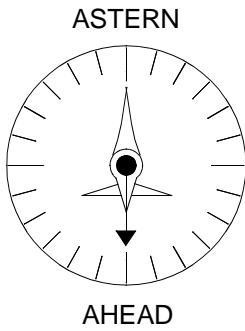


STRAIGHT
AHEAD



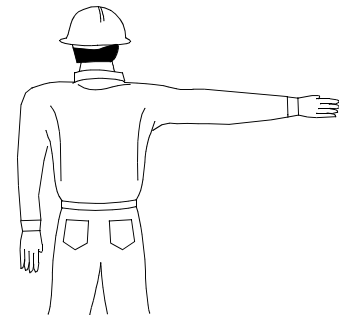
STRAIGHT AHEAD

< PORT SIDE INDICATORS >

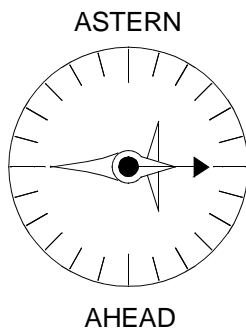
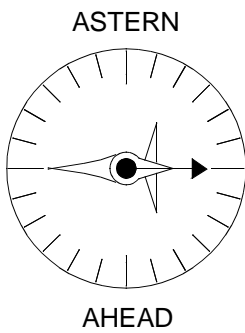


< STARBOARD SIDE INDICATORS >

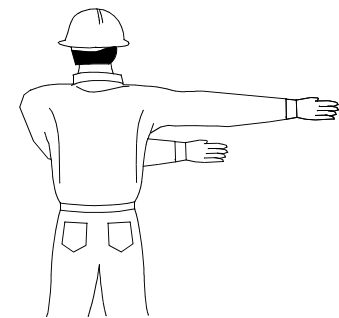
RIGHT
FULL
TURN



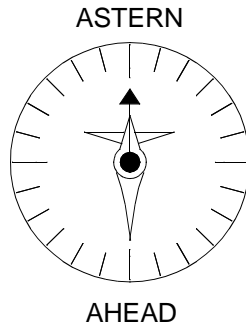
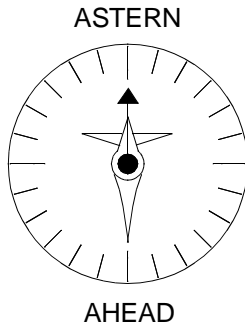
STARBOARD FULL



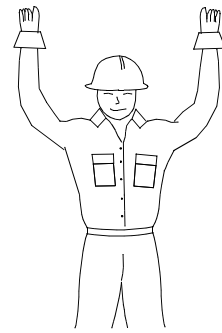
RIGHT
HARD
TURN



STARBOARD HARD

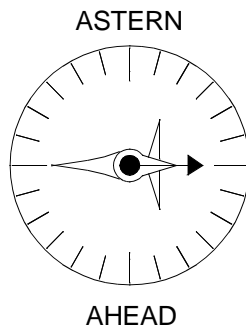
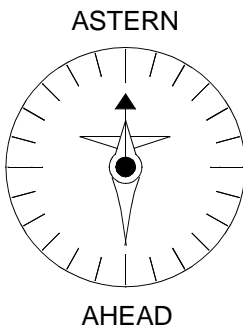


STRAIGHT
BACK



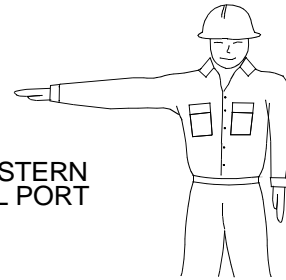
STRAIGHT BACK

< PORT SIDE INDICATORS >

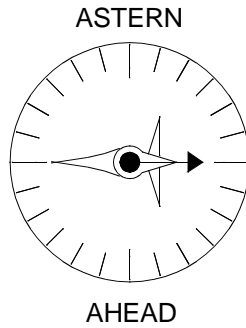
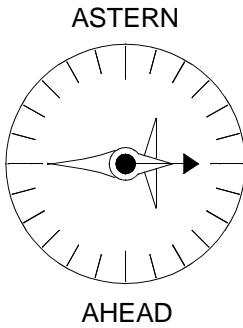


< STARBOARD SIDE INDICATORS >

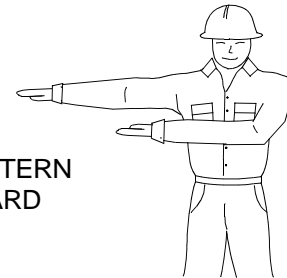
SWING STERN
TO FULL PORT



SWING STERN
PORT FULL

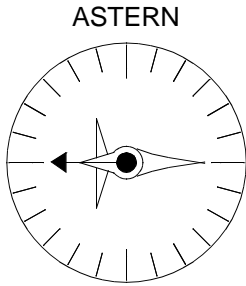


SWING STERN
PORT HARD



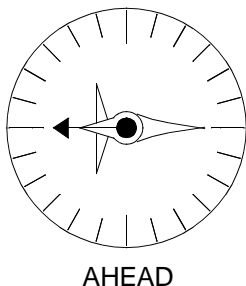
SWING STERN
PORT HARD

< PORT SIDE INDICATORS >



ASTERN

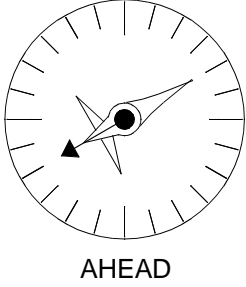
AHEAD



ASTERN

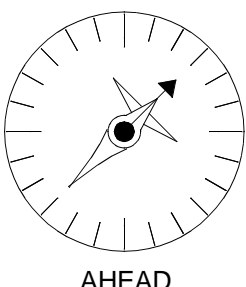
AHEAD

< PORT SIDE INDICATORS >



ASTERN

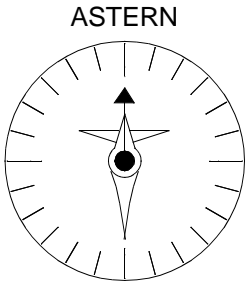
AHEAD



ASTERN

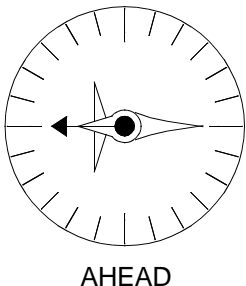
AHEAD

< STARBOARD SIDE INDICATORS >



ASTERN

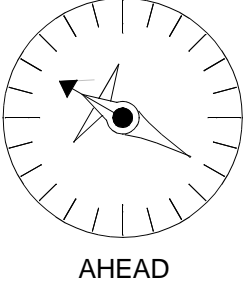
AHEAD



ASTERN

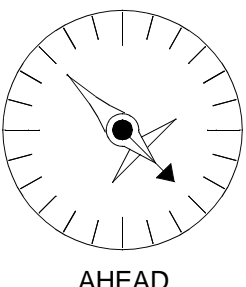
AHEAD

< STARBOARD SIDE INDICATORS >



ASTERN

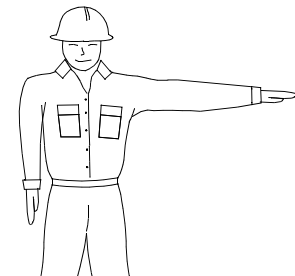
AHEAD



ASTERN

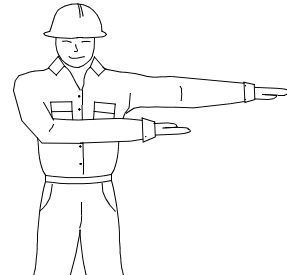
AHEAD

SWING STERN TO STARBOARD FULL



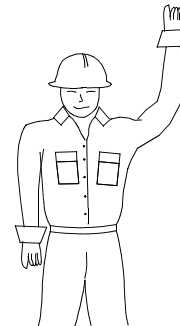
SWING STERN TO STARBOARD FULL

SWING STERN TO STARBOARD HARD



SWING STERN STARBOARD HARD

WALK STARBOARD

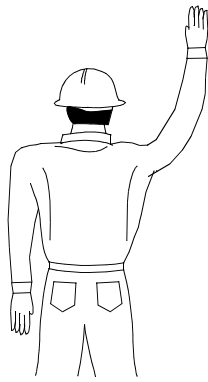


SWING STERN STARBOARD EASY

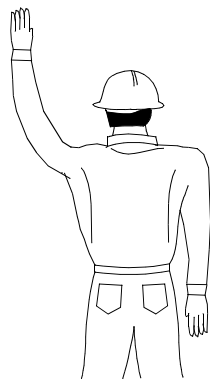
WALK PORT



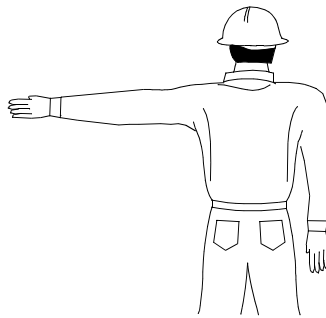
SWING STERN PORT EASY



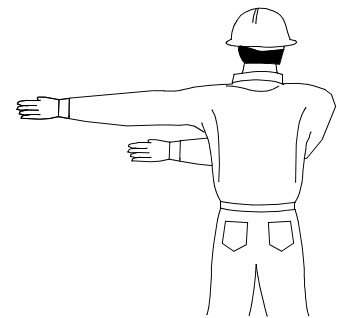
STARBOARD



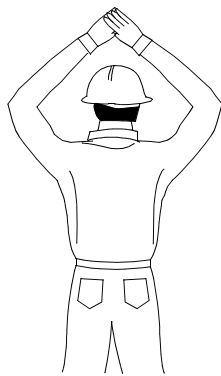
PORT EASY



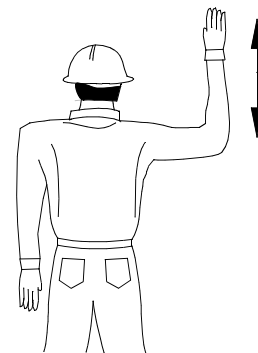
PORT FULL



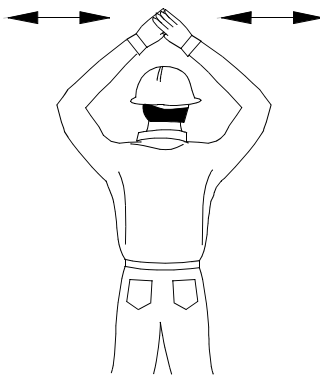
PORT HARD



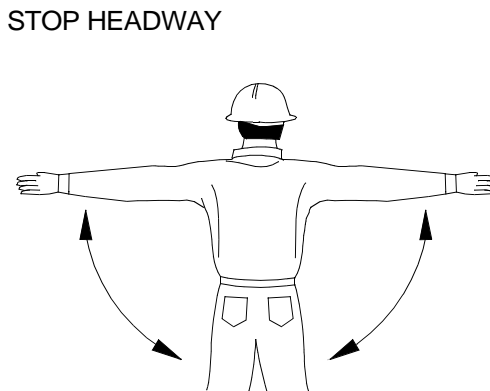
DISENGAGE ENGINES



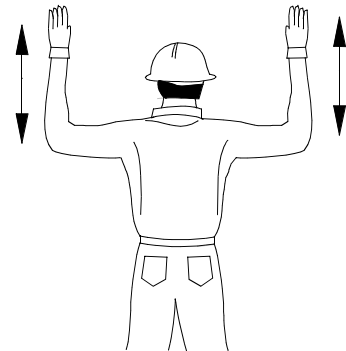
APPROPRIATE WHISTLE SIGNAL



STOP HEADWAY



SLOW DOWN



SPEED UP

CONDUCT ENGINE SHUTDOWN CHECKS IN THE CF OPERATOR CHECKLIST

Table 2. CF Operator Engine Shutdown Checklist.

ITEM NO.	PROCEDURE	INITIAL WHEN COMPLETED																					
1	Position the throttle control levers in the idle position (Port and Stbd).																						
2	Disengage clutch controls (Port and Stbd).																						
3	Run engines at idle (790 - 800 RPM) for five minutes before engine shutdown.																						
4	Depress STOP push button to shut down each engine.																						
5	Switch ENGINE POWER toggle switch to the OFF position for each engine.																						
6	Switch VENT FAN toggle switch for each propulsion module to the OFF position.																						
7	Perform after operation PMCS.																						
8	Latch exhaust flappers (Port and Stbd).																						
9	Position 50A disconnect circuit breaker to OFF (open) position (Port and Stbd).																						
10	Position Battery Selector Switch to OFF (open) position (Port and Stbd).																						
11	Place all circuit breaker switches on Port and Stbd Propulsion Module Circuit Breaker Panels (A6) in the down (OFF) position.																						
12	Place all circuit breaker switches on Operators Cab Circuit Breaker Panel (A3) to the down (OFF) position.																						
13	Check below decks to ensure no personnel are present below decks.																						
14	Close and dog all propulsion module access hatches.																						
15	Remove communications equipment from operators cab, as necessary.																						
16	Remove or secure all tools and crew equipment.																						
17	Secure and lock operators cab windows and door.																						
<table border="0" style="width:100%"> <tr> <td style="width:40%">NAME and RANK (Print)</td> <td style="width:40%">SIGNATURE:</td> <td style="width:20%">DATE:</td> </tr> <tr> <td colspan="3"> </td> </tr> <tr> <td>CHIEF ENGINEER</td> <td></td> <td></td> </tr> <tr> <td>NAME and RANK (Print)</td> <td>SIGNATURE:</td> <td>DATE:</td> </tr> <tr> <td colspan="3"> </td> </tr> <tr> <td>VESSEL MASTER</td> <td></td> <td></td> </tr> <tr> <td>NAME and RANK (Print)</td> <td>SIGNATURE:</td> <td>DATE:</td> </tr> </table>			NAME and RANK (Print)	SIGNATURE:	DATE:				CHIEF ENGINEER			NAME and RANK (Print)	SIGNATURE:	DATE:				VESSEL MASTER			NAME and RANK (Print)	SIGNATURE:	DATE:
NAME and RANK (Print)	SIGNATURE:	DATE:																					
CHIEF ENGINEER																							
NAME and RANK (Print)	SIGNATURE:	DATE:																					
VESSEL MASTER																							
NAME and RANK (Print)	SIGNATURE:	DATE:																					

END OF WORK PACKAGE

**OPERATOR MAINTENANCE
CAUSEWAY FERRY
VHF/FM HANDHELD TRANSCEIVER
OPERATION UNDER USUAL CONDITIONS**

INITIAL SETUP:

Tools

- Gloves, Men's and Women's (Leather Palm) (Item 31, WP 0105 00)
- Goggles, Sun, Wind and Dust (Safety) (Item 34, WP 0105 00)
- Life Preserver, Vest (Item 45, WP 0105 00)
- Helmet, Safety (Brown) (Item 40, WP 0105 00)

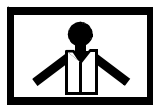
Personnel Required

Seaman 88K

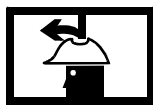
OPERATING PROCEDURES - OPERATE THE VHF/FM HANDHELD TRANSCEIVER

INITIAL SETUP OF VHF/FM HANDHELD TRANSCEIVER

WARNING



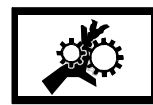
VEST



HELMET PROTECTION



HEAVY PARTS



MOVING PARTS



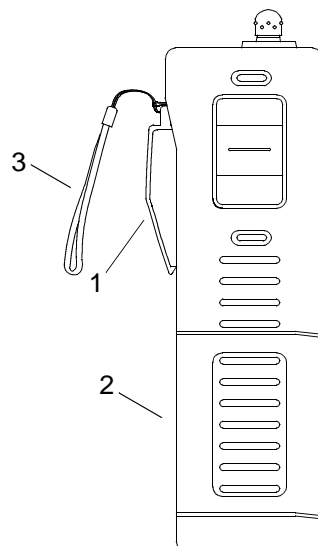
EXPLOSION

All personnel must wear personal flotation device, hard hat, safety shoes and gloves during CF operations and maintenance. Failure to observe these precautions could result in serious injury or death.

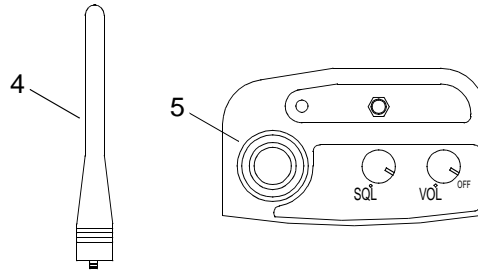
To avoid the risk of explosion, do not operate radio where explosive vapors may be present. Failure to observe these precautions could result in serious injury or death.

A metal object shorting the terminals may cause the battery to explode. Failure to observe this precaution could result in serious injury or death.

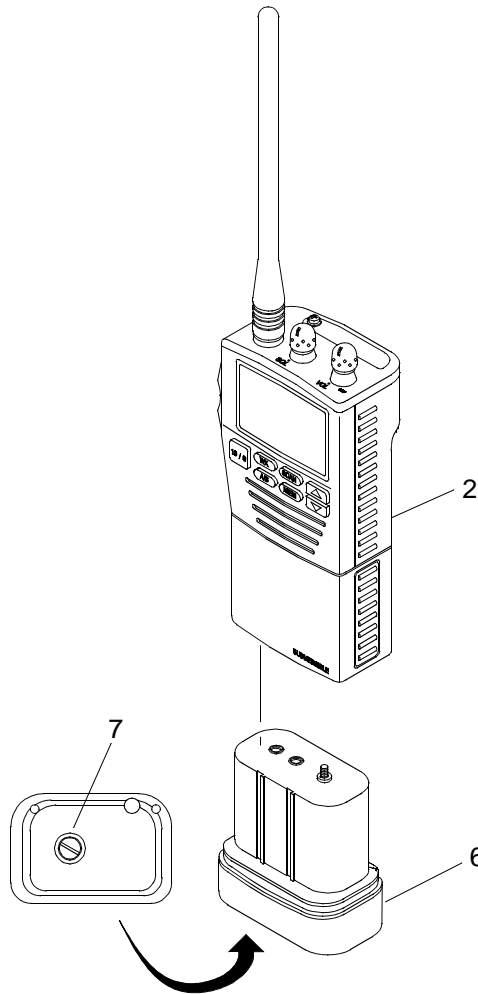
1. Install the belt clip (1) on the transceiver (2), if desired.



2. Install the nylon strap (3) on the belt clip (1), if desired.
3. Install the antenna (4) in the transceiver antenna receptacle (5).



4. Install the CNB350 nickel cadmium battery pack (6) in the transceiver (2).



- a. Slide the battery pack (6) into the battery cavity.
- b. Rotate the battery lock screw (7) counterclockwise two revolutions prior to tightening.
- c. Turn the battery lock screw (7) clockwise until hand tight.

BATTERY CHARGING

WARNING

Shorting the battery terminals that charge the transceiver can cause sparks, severe overheating, burns and battery damage. Do not place an uninstalled battery pack in the vicinity of metal objects that may short the terminals. Failure to observe this precaution could result in serious injury or death.

To avoid risk of explosion and injury, do not operate radio where explosive vapors may be present. Failure to observe these precautions could result in serious injury or death.

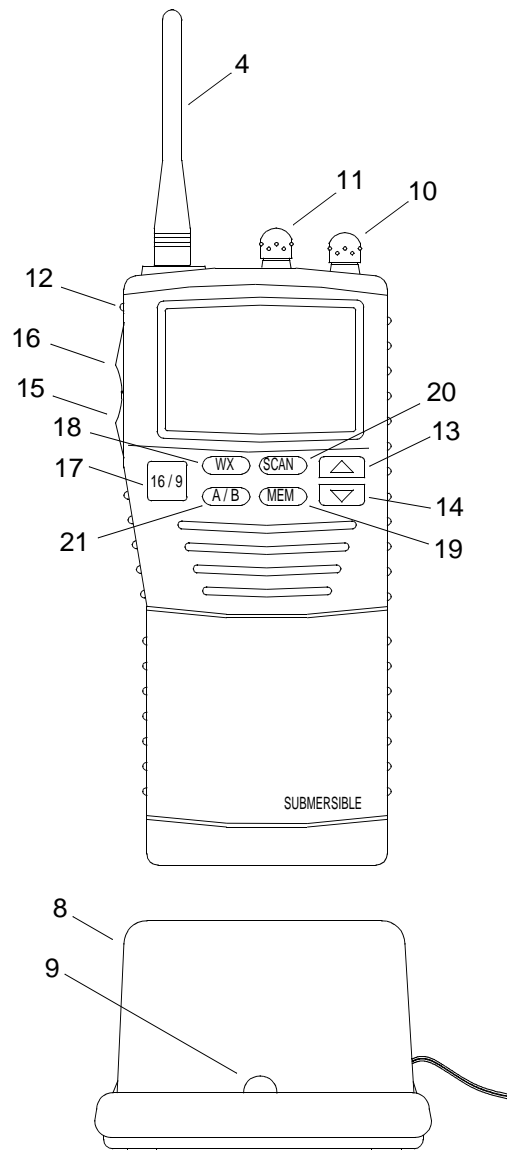
NiCad batteries must be disposed of properly. Battery may explode if incinerated, causing injury or death. Contact unit supply for proper disposal instructions.

CAUTION

Never plug the power supply to the CCA250 charge adaptor except with a CAW240, CWC230 or CWC232 adaptor. Damage to power supply could occur.

Charging the transceiver battery for more than 16 hours with the battery charge system can shorten battery life and cause other components to fail. Battery packs may be left in the CSA280 chargers without harm to either the battery pack or charger.

1. Turn the POWER/VOLUME knob (10) counterclockwise to turn the transceiver off.
2. Insert the transceiver (2) into the charger (8) to light charge indicator (9) and to begin charging.



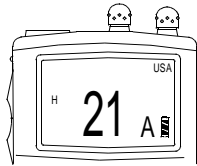
3. Remove the transceiver (2) from the charger (8) when battery charge time has elapsed.

TURNING RADIO ON**NOTE**

Water resistance of the transceiver is assured only when the battery pack and antenna are attached to the transceiver.

Never key the transceiver without the antenna attached. Damage to the transceiver will occur.

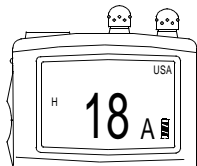
1. Turn the POWER/VOLUME knob (10) clockwise to turn the transceiver on.



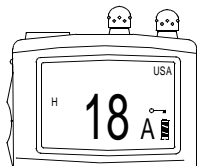
2. Rotate the SQUELCH CONTROL knob (11) fully counterclockwise to the SQUELCH OFF position.
3. Rotate the POWER/VOLUME CONTROL knob (10) until the noise or audio from the speaker can be heard.
4. Select a channel that has no voice transmissions occurring.
5. To find the squelch threshold, rotate the SQUELCH CONTROL knob (2) clockwise until the noise stops.
6. To turn on the radio light for 5 seconds, press the LAMP key (12)
7. To turn off the light sooner than 5 seconds, press the LAMP key (12).

RECEIVING RADIO TRANSMISSIONS

1. Press the UP ARROW key (13) or DOWN ARROW key (14) to change channels.

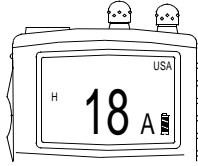


2. Press the LAMP/KEY LOCK key (12) for 1 second to lock the channel in the operating mode.
3. Ensure that the key lock symbol (12) appears on the display to indicate that the channel is locked.



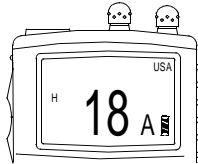
4. To unlock the channel, press the LAMP/KEY LOCK key (12) for 1 second.

5. Ensure that the key lock symbol disappears from the display to indicate that the channel is unlocked.

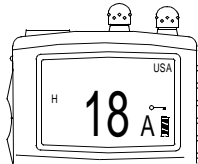


TRANSMITTING

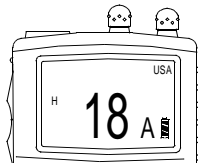
1. Press the UP ARROW key (13) or DOWN ARROW key (14) to change channels.



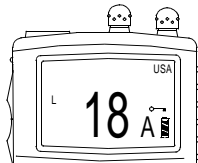
2. Adjust squelch as required.
3. Press the LAMP/KEY LOCK key (12) for 1 second to lock the channel in the operating mode.



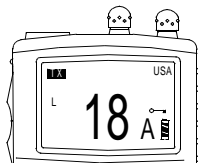
4. To unlock the channel, press the LAMP/KEY LOCK key (12) for 1 second.



5. Press the H/L key (15) until L is displayed for transmissions over a short distance.



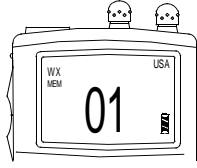
6. If low power is not effective, press the H/L key (15) until H is displayed.
7. Press the PTT switch (16) to transmit.



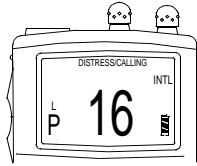
8. Release the PTT switch (16) when transmission is completed.

OPERATING MODES

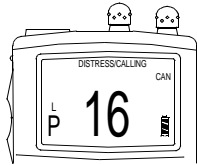
1. To access the USA operating mode, hold down the 16/9 key (17) and press the WX key (18) to change the mode of the receiver to USA.



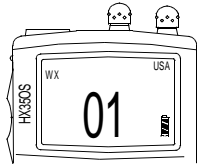
2. To access the INTERNATIONAL operating mode, hold down the 16/9 key (17) and press the WX key (18) to change the mode of the receiver to INTL.



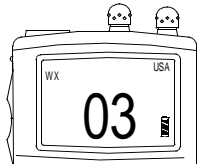
3. To access the CANADIAN operating mode, hold down the 16/9 key (17) and press the WX key (18) to change the mode of the receiver to CAN.


NOAA WEATHER CHANNELS

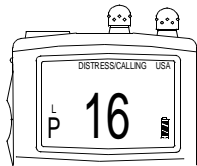
1. Press the WX key (18) to receive a weather channel.



2. Press the UP ARROW key (13) or DOWN ARROW key (14) to change to other weather channels.

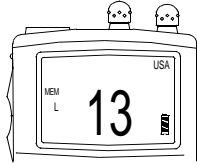


3. Press the WX key (18) to exit from the weather channels and return to the previous non-weather channel.



SCANNING

1. Select the desired channel to be scanned using the UP ARROW key (13) or DOWN ARROW key (14).
2. Press the MEM key (19) to store the channel into the transceiver's memory.



3. Repeat steps one and two until all channels to be scanned are stored in the transceiver's memory.
4. Press the SCAN key (20) to start scan.
5. Press the SCAN key (20) to stop the scan.

DELETE SCAN MEMORY

1. To delete a channel from the transceiver's scan memory, select the desired channel using the UP ARROW key (13) or DOWN ARROW key (14).
2. Press the MEM key (19) while the channel number to be deleted from the scan memory is displayed.
3. Delete the complete scan memory by resetting the transceiver's microprocessor.
 - a. Turn the transceiver off using the POWER/VOLUME CONTROL knob (10).
 - b. To return to the factory default settings, press the SCAN key (20) and the WX key (18) while turning on the transceiver.

PRIORITY SCAN

1. To change from channel 16 to channel 09 and set the priority channel, hold down the 16/9 key (17) and press the MEM key (19).
2. Press MEM key (19) to change to channel number programmed as A channel.
3. Press MEM key (19) to change to channel number programmed as B channel.
4. Press the SCAN key (20) at least 1 second for priority scanning during normal scanning.

WEATHER ALERT**NOTE**

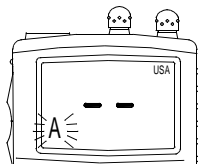
A loud tone will indicate that the transceiver is in the weather alert mode. When a weather alert is received, scanning stops and the transceiver enters the weather alert mode.

1. Press the SCAN key (20) to start scanning the memorized weather channels along with the other regularly scanned channels.
2. Press the WX key (18) to stop the alert tone and receive the voice information on the weather channel.

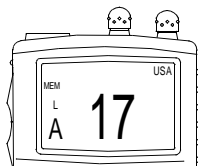
CHANNEL A/B INSTANT ACCESS**NOTE**

Ensure that a blinking letter A and dashes appear on the display to indicate that no channel has been selected for A.

1. Press the A/B key (21) and turn the transceiver on.



2. Using the UP ARROW key (13) and DOWN ARROW key (14), enter the desired channel.
3. Press the MEM key (19) to stop displayed A blinking and display the A channel.



4. Turn the radio off and back on using the POWER/VOLUME knob (10) to return to normal radio mode.

END OF WORK PACKAGE

**OPERATOR MAINTENANCE
CAUSEWAY FERRY
AN/PSN-11 INTERFACE AND SWITCHBOX
OPERATION UNDER USUAL CONDITIONS**

INITIAL SETUP:**Tools**

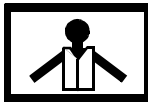
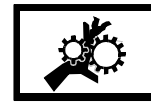
Gloves, Men's and Women's (Leather Palm) (Item 31, WP 0105 00)
Goggles, Sun, Wind and Dust (Safety) (Item 34, WP 0105 00)
Life Preserver, Vest (Item 45, WP 0105 00)
Helmet, Safety (Brown) (Item 40, WP 0105 00)

Personnel Required

Seaman 88K

OPERATING PROCEDURES - OPERATE THE AN/PSN-11 INTERFACE AND SWITCHBOX

WARNING

**VEST****HELMET PROTECTION****HEAVY PARTS****MOVING PARTS**

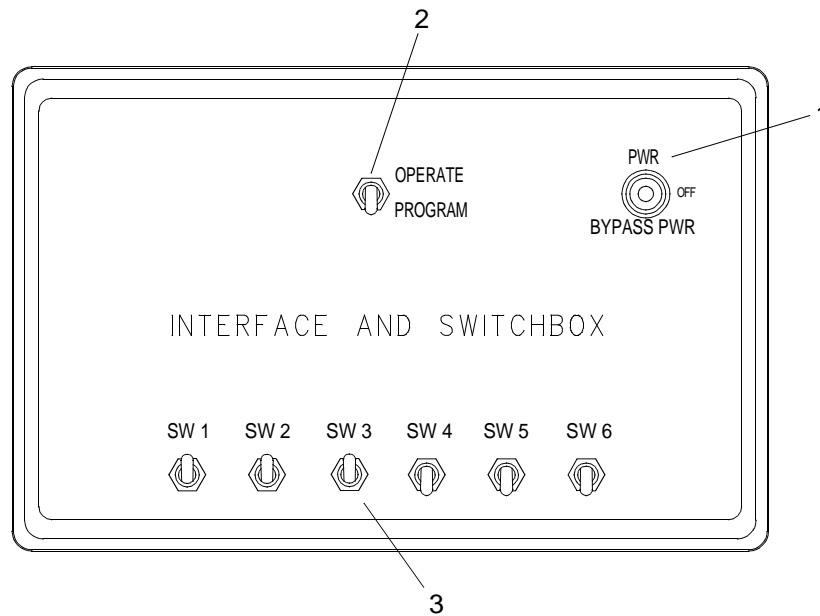
All personnel must wear personal flotation device, hard hat, safety shoes and gloves during CF operations and maintenance. Failure to observe these precautions could result in serious injury or death.

During tactical operations, switch SW3 should remain in the off position and used only as necessary. Failure to comply could result in unwanted interrogation of position. Enemy knowledge of position in wartime could result in injury or death to personnel.

NOTE

The interface and switchbox will not transmit the current position to any interfaced devices with the OPERATE/PROGRAM switch in the program position or the power switch in BYPASS PWR position.

1. Place the power switch (1) in the PWR position.



2. Place the power switch (1) in the OFF position to turn the power to the PLGR off.
3. Place the OPERATE/PROGRAM switch (2) in the OPERATE position.
4. Place the OPERATE/PROGRAM switch (2) in the PROGRAM position to provide a direct programming link between the PLGR and a data terminal.
5. Place SW3 (3) in the on (up) position to turn the GPS signal on from the PLGR.
6. Place SW3 (3) in the off (down) position to turn the GPS signal off from the PLGR.

END OF WORK PACKAGE

**OPERATOR MAINTENANCE
CAUSEWAY FERRY
PUBLIC ADDRESS SET (LOUDHAILER)
OPERATION UNDER USUAL CONDITIONS**

INITIAL SETUP:

Tools

- Gloves, Men's and Women's (Leather Palm) (Item 31, WP 0105 00)
- Goggles, Sun, Wind and Dust (Safety) (Item 34, WP 0105 00)
- Life Preserver, Vest (Item 45, WP 0105 00)
- Helmet, Safety (Brown) (Item 40, WP 0105 00)

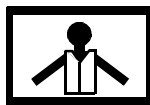
Personnel Required

Seaman 88K

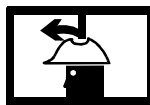
OPERATING PROCEDURES - OPERATE THE PUBLIC ADDRESS SET (LOUDHAILER)

LCD DISPLAY AND CONTROL KNOBS

WARNING



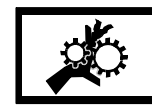
VEST



HELMET PROTECTION



HEAVY PARTS

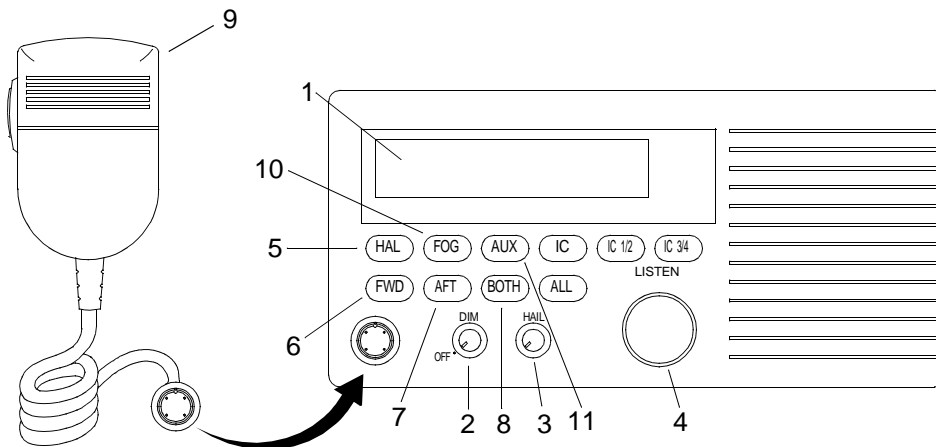


MOVING PARTS

All personnel must wear personal flotation device, hard hat, safety shoes and gloves during cf operations and maintenance. failure to observe these precautions could result in serious injury or death.

NOTE

The LCD display (1) shows the operation status of the loudhailer in bright bold letters. the display is illuminated in a blue green color with adjustable backlighting for optimal viewing in all light conditions.

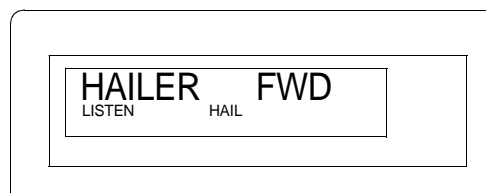


1. Turn power on and off and control the display lighting level.

- a. Rotate the on/off/dim control knob (2) clockwise to turn the loudhailer on. adjust the knob to adjust the display lighting level.
 - b. Rotate the on/off/dim control knob (2) counterclockwise to turn the loudhailer off.
2. Adjust the volume level to the hailer horns.
 - a. Turn the hail volume control knob (3) clockwise to increase the volume to the hailer horns.
 - b. Turn the hail volume control knob (3) counterclockwise to reduce the volume to the hailer horns.
 3. Adjust the listening volume.
 - a. Turn the listen volume control knob (4) clockwise to increase the volume.
 - b. Turn the listen volume control knob (4) counterclockwise to decrease the volume.

OPERATING IN THE LOUDHAILER MODE

1. Press the HAIL key (5). The loudhailer is now in the HAIL mode. HAILER appears in the LCD display operating mode window.



2. Press the FWD speaker key (6), AFT speaker key (7) or BOTH (8) to select the forward speaker, aft speaker or both. FWD, AFT or BOTH will appear in the LCD display speaker station window.
3. Press the microphone PUSH TO TALK switch (9). TALK will appear in the LCD display speaker station window.
4. Adjust the HAIL volume knob (3) to the desired sound level.

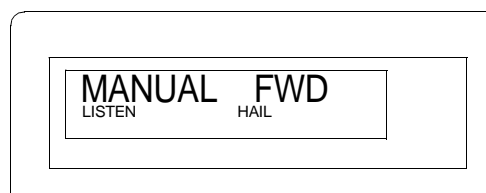
OPERATING IN THE FOG MODE

1. Press the FOG key (10) to select the type of fog signal to be transmitted. Repeatedly pressing the key will allow access to nine different fog signals. The type of fog alarm will appear in the LCD display.

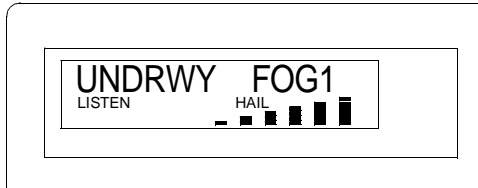
NOTE

The manual type of fog signal is a manually controlled signal used as a horn signal for passing, etc. as described in 'Rules of the Road' - Section 35.

2. Select manual type of fog signal. In this mode, the horn sounds when the microphone is pressed. The length and timing of the horn blasts are controlled with the PUSH TO TALK switch (9).

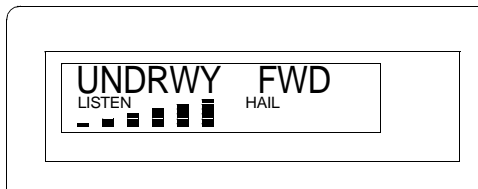


- a. Press the PUSH TO TALK switch (9) to sound the horn. MANUAL will appear in the LCD display.
 - b. Control the length and timing of the horn blasts by pushing and releasing the PUSH TO TALK switch (9).
3. Select UNDERWAY FOG for a programmed automatic fog signal used to signal when a powered vessel is underway. UNDRWY and FOG 1 will appear in the display when selected.

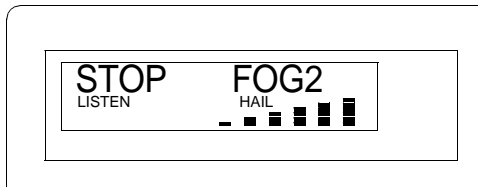


NOTE

After one second FOG 1 will disappear and UNDRWY and FWD will appear. The FOG 1 alarm pattern is one 5 second blast at 2 minute intervals.

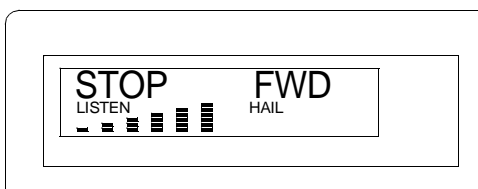


4. Select STOP FOG 2 for a programmed automatic fog signal used to signal that a vessel is not moving. STOP and FOG 2 will appear in the display when selected.

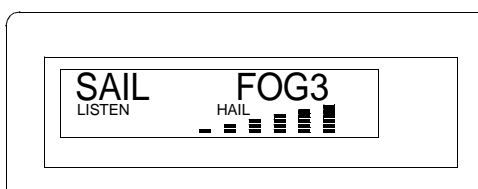


NOTE

After one second FOG 2 will disappear and STOP and FWD will appear. The FOG 2 alarm pattern is: Two 5 second blasts, with a 2 second interval between each blast repeated every 2 minutes.

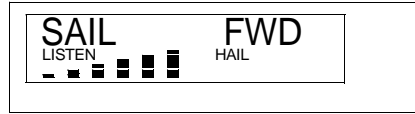


5. Select SAIL FOG 3 for a programmed automatic fog signal for sailboats, fish boats or towboats. SAIL and FOG 3 will appear in the display when selected.

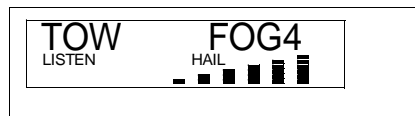


NOTE

After one second FOG 3 will disappear and SAIL and FWD will appear. The FOG 3 alarm pattern is: One 5 second blast followed by two 1 second blasts, at 2 second intervals, repeated every 2 minutes.

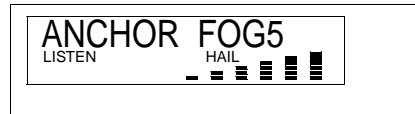


6. Select TOW FOG 4 for a programmed automatic fog signal used to signal that a vessel is under tow. TOW and FOG 4 will appear in the display when selected.



NOTE

After one second FOG 4 will disappear and TOW and FWD will appear. The FOG 4 alarm pattern is: One 5 second blast followed by three 1 second blasts, at 2 second intervals, repeated every 2 minutes.

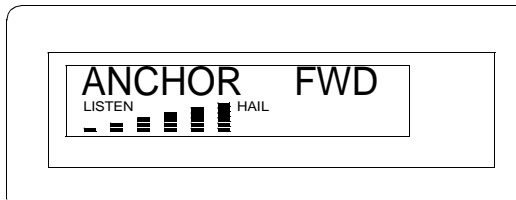


7. Select ANCHOR FOG 5 for a programmed automatic fog signal for a vessel at anchor. ANCHOR and FOG 5 will appear in the display when selected.

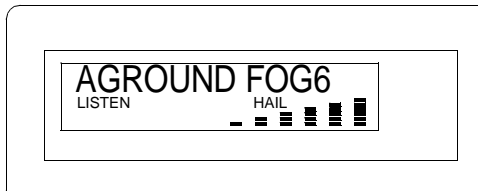


NOTE

After one second FOG 5 will disappear and ANCHOR and FWD will appear. The FOG 5 alarm pattern is: A rapidly ringing bell tone will sound for a duration of at least 5 seconds, with a repetition interval not to exceed 1 minute.

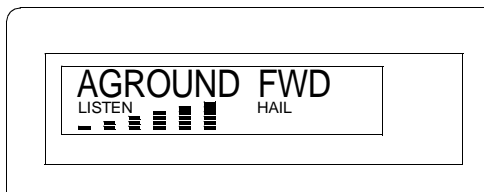


8. Select AGROUND FOG 6 for a programmed automatic fog signal for a vessel aground. AGROUND and FOG 6 will appear in the display when selected.

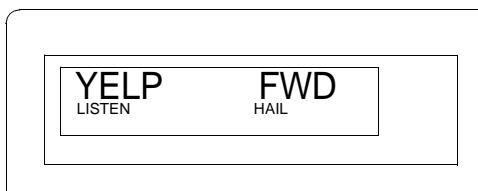


NOTE

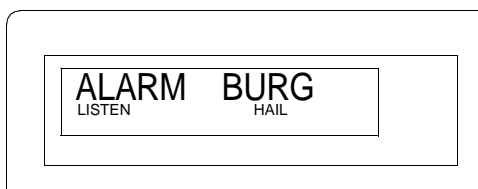
After one second FOG 6 will disappear and AGROUND and FWD will appear. The FOG 6 alarm pattern is: Three bell tone sounds, at 1 second intervals, followed by a rapidly ringing bell for a duration of 5 seconds, followed again by three bell tone sounds, at 1 second intervals. This signal is repeated once every minute.



9. Select YELP for a manually activated signal for regulatory vessels such as: Police, Fish and Game, US Coast Guard, etc. YELP will appear in the display when selected. Press the PUSH TO TALK switch (9) on the microphone to create the YELP sound.

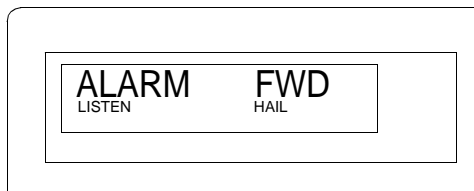


10. Select ALARM for an automatic signal used as a burglar alarm when activated. ALARM will appear in the display when selected.

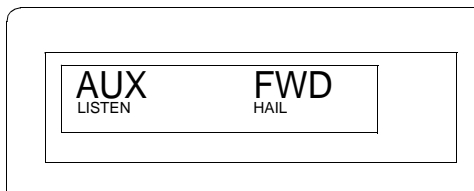


NOTE

After one second ALARM will disappear and ALARM and FWD will appear. An external, normally open type, sensor is required to operate this feature. This feature is not used on the mobile causeway.



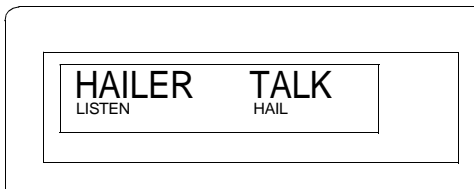
11. Select AUX to allow the crew to monitor the VHF/FM DSC transceiver when not in the operators cab. VHF/FM radio transmissions received are broadcast through the hailer horns.



NOTE

The speaker station display indicates which speaker station has been selected; FWD, AFT, BOTH or ALL (not used). In the FOG mode the speaker station display will temporarily indicate which FOG mode number has been selected when the FOG key is pushed. One second later, the normal speaker station selection will reappear.

12. Press the microphone PUSH TO TALK key (9) in the HAIL or INTERCOM modes and ensure that TALK appears in the speaker station display confirming that voice transmission is possible by speaking into the microphone.

**OPERATING IN THE AUXILIARY MODE**

1. Press the PUSH TO TALK switch (9) on the microphone to control manual operation. Manual operation is used for MANUAL and YELP modes only.
2. Press the FWD speaker key (6) to select the forward speaker, AFT speaker key (7) to select the aft speaker or BOTH (8) to select both forward and aft speakers. FWD, AFT or BOTH will appear in the LCD display speaker station window.
3. Adjust the HAIL volume knob (3) to the desired sound level.
4. Press the AUX key (11). The loudhailer is now in the AUX mode. AUX appears in the LCD display operating mode window.
5. Press the FWD speaker key (6) to select the forward speaker, AFT speaker key (7) to select the aft speaker or BOTH (8) to select both forward and aft speakers. FWD, AFT or BOTH will appear in the LCD display speaker station window.
6. Adjust the HAIL volume knob (3) to the desired sound level.

END OF WORK PACKAGE

**OPERATOR MAINTENANCE
CAUSEWAY FERRY
AN/VRC-88D SINGARS RADIO
OPERATION UNDER USUAL CONDITIONS**

INITIAL SETUP:**Tools**

Gloves, Men's and Women's (Leather Palm) (Item 31, WP 0105 00)
Goggles, Sun, Wind and Dust (Safety) (Item 34, WP 0105 00)
Life Preserver, Vest (Item 45, WP 0105 00)
Helmet, Safety (Brown) (Item 40, WP 0105 00)

Personnel Required

Seaman 88K

References

TM 11-5820-890-10-8

OPERATING PROCEDURES - OPERATE THE AN/VRC-88D SINGARS RADIO

WARNING



VEST



HELMET PROTECTION



HEAVY PARTS



MOVING PARTS

All personnel must wear personal flotation device, hard hat, safety shoes and gloves during CF operations and maintenance. Failure to observe these precautions could result in serious injury or death.

Refer to the AN/VRC-88D SINGARS Radio Operators Manual, TM 11-5820-890-10-8, for operating procedures.

END OF WORK PACKAGE

**OPERATOR MAINTENANCE
CAUSEWAY FERRY
VHF/FM DSC TRANSCEIVER
OPERATION UNDER USUAL CONDITIONS**

INITIAL SETUP:

Tools

- Gloves, Men's and Women's (Leather Palm) (Item 31, WP 0105 00)
- Goggles, Sun, Wind and Dust (Safety) (Item 34, WP 0105 00)
- Life Preserver, Vest (Item 45, WP 0105 00)
- Helmet, Safety (Brown) (Item 40, WP 0105 00)

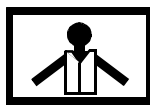
Personnel Required

Seaman 88K

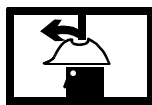
OPERATING PROCEDURES - PERFORM INITIAL SETUP OF THE VHF/FM DSC TRANSCEIVER

ENTER USER DIGITAL SELECTIVE CALL (DSC) ID NUMBER

WARNING



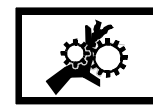
VEST



HELMET PROTECTION



HEAVY PARTS



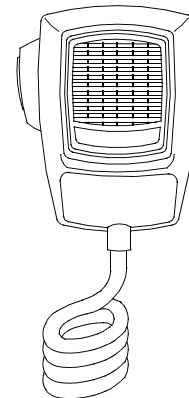
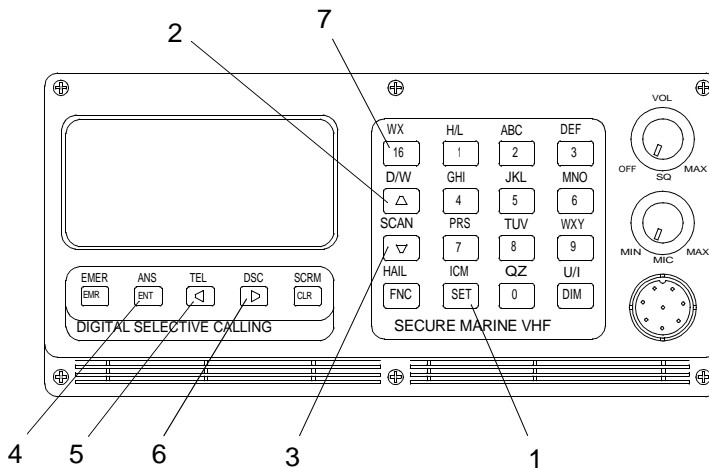
MOVING PARTS

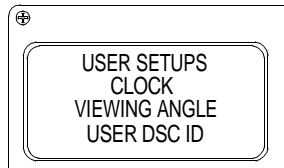
All personnel must wear personal flotation device, hard hat, safety shoes and gloves during CF operations and maintenance. Failure to observe these precautions could result in serious injury or death.

NOTE

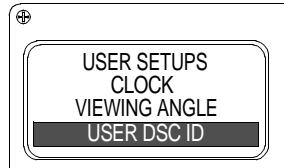
A Ship Station Identity number may be entered or changed only one time. Any further attempts to change the number will cause USER DSC ID CAN NO LONGER BE CHANGED to appear in the display and the last ID number entered will become permanent. The transceiver must be returned to the factory or authorized dealer to clear this condition.

1. To enter your Ship Station Identity number, press the SET key (1). The USER SETUPS menu will appear.

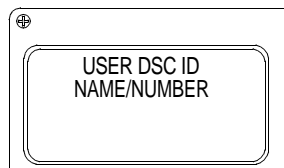




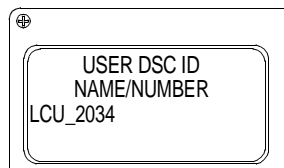
2. Press the UP ARROW KEY (2) or DOWN ARROW key (3) to select USER DSC ID with the selection bar.



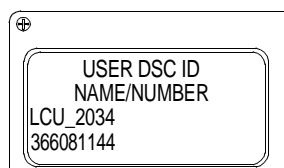
3. Press the ENT key (4). Ensure that the DSC ID, NAME/NUMBER page appears with the lower two lines of the display showing dashes unless a name and number have been previously entered.



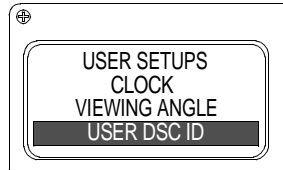
4. Enter a letter into the name line of the display.
- Press the appropriate number key repeatedly until the desired letter or the number appears in the character position.
 - Press the next key to be entered and the entry point will move to the next position automatically.
 - Press the RIGHT ARROW key (6) to move the entry point to the next character position if more than one letter from the same key must be entered in succession.
 - Press the LEFT ARROW key (5) to backspace and correct an entry if necessary.
 - Press the DOWN ARROW key (3) to move the entry point to the ID number line when the name is complete.



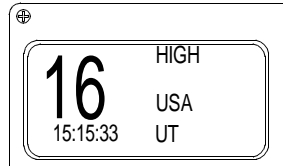
5. Press the appropriate number keys to enter the Ship Station Identification number. To correct an entry, press the LEFT ARROW key (5) to backspace. To skip a digit, press the RIGHT ARROW key (6).



6. When all information is displayed correctly, press the ENT key (4) to complete the operation and return to the USER SETUPS menu.



7. Press key (7) to return to normal operation.



8. Perform user setups. (WP 0033 00)

END OF WORK PACKAGE

**OPERATOR MAINTENANCE
CAUSEWAY FERRY
VHF/FM DSC TRANSCEIVER
OPERATION UNDER USUAL CONDITIONS**

INITIAL SETUP:**Tools**

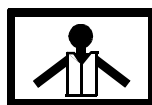
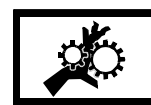
Gloves, Men's and Women's (Leather Palm) (Item 31, WP 0105 00)
Goggles, Sun, Wind and Dust (Safety) (Item 34, WP 0105 00)
Life Preserver, Vest (Item 45, WP 0105 00)
Helmet, Safety (Brown) (Item 40, WP 0105 00)

Personnel Required

Seaman 88K

OPERATING PROCEDURES - OPERATE THE VHF/FM DSC TRANSCEIVER**MODEL IDENTIFICATION**

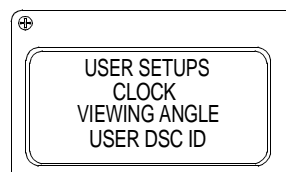
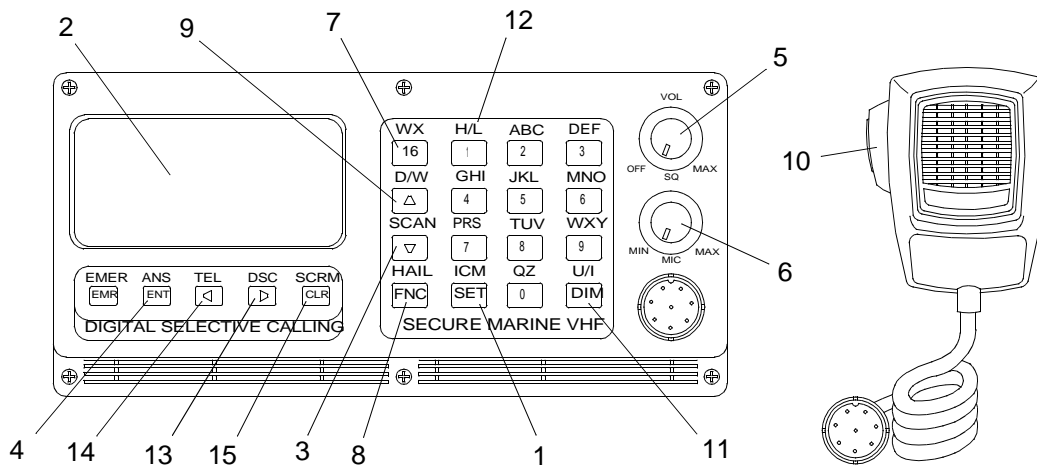
WARNING

**VEST****HELMET PROTECTION****HEAVY PARTS****MOVING PARTS**

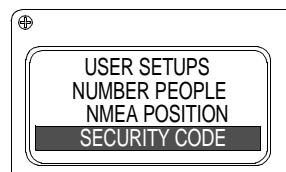
All personnel must wear personal flotation device, hard hat, safety shoes and gloves during CF operations and maintenance. Failure to observe these precautions could result in serious injury or death.

During tactical operations, any vessel can request position through the VHF/FM DSC transceiver. There is no request authorization required nor can this request be seen by the vessel operator. During tactical operations, switch SW3 on the AN/PSN-11 Interface and switchbox should remain in the OFF position and used only as necessary to prevent unwanted interrogation of position for vessels equipped with a DSC transceiver not manufactured to military specification. Vessels operating with a DSC transceiver manufactured to military specification may leave switch SW3 on the AN/PSN-11 Interface and switchbox in the on position, but must operate with the covert mode enabled. Failure to comply during tactical operations could result in injury or death to personnel.

1. To determine the type of transceiver installed, military specification or non-military specification, press the SET key (1). The USER SETUPS menu will appear in the LCD display (2).



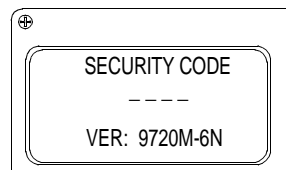
2. Press the DOWN ARROW key (3) until SECURITY CODE is highlighted.



NOTE

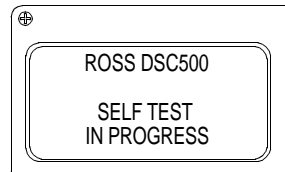
A software version number appears on the bottom line of the display. The letter “M” after the four numerical digits denotes that the transceiver has been manufactured to military specification. Absence of the letter “M” denotes that the transceiver has not been manufactured to military specification.

3. Press the ENT key (4).



POWER ON AND VOLUME

1. Rotate the VOLUME KNOB (5) clockwise to turn the power on.



2. Rotate the knob further clockwise to adjust the audio output level. If a self-test fails, a message describing the failure will be displayed.

POWER OFF

1. Rotate the knob further counterclockwise to decrease the audio output level.
2. Rotate the VOLUME KNOB (5) counterclockwise until it clicks to turn the power off. The display becomes blank and the transceiver does not receive any calls.

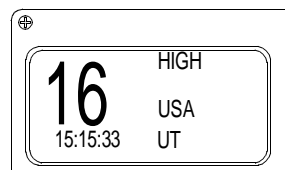
SQUELCH

1. Rotate the SQUELCH KNOB (6) counterclockwise until background noise is heard.
2. Adjust the knob clockwise until slightly beyond the point where noise is muted.

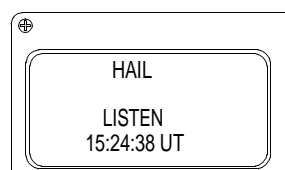
PRIMARY MODE**NOTE**

The PRIMARY mode is the basic communication mode of the transceiver. In voice contacts, both calling and routine communications use the PRIMARY mode. Even when a DSC call is placed or received, the routine communications that follow the DSC operations use the PRIMARY mode.

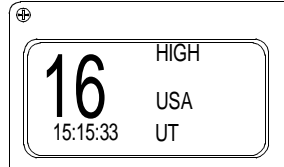
1. Press the 16 key (7), and any function, active or pending, is canceled and the PRIMARY mode display appears with channel 16 selected.



2. Press two channel number keys, and in all modes, except open edits where alphanumeric entry is expected, pressing two channel number keys invokes the PRIMARY mode and selects the entered channel number.
3. Press the function keys for the current active mode again. For example, to select the HAIL mode, press the FNC/HAIL key (8) twice. The HAIL display appears.

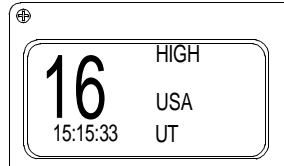


4. To cancel the HAIL mode, press the FNC/HAIL key (8) twice again and the PRIMARY mode display will appear.



CHANGING CHANNELS

1. To select the calling and safety channel, press the 16 key (7). The PRIMARY mode display appears with channel 16 selected as the working channel.

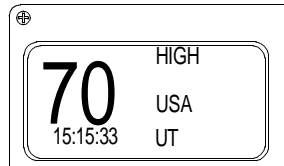


2. To select a working channel, press the UP ARROW key (9) or DOWN ARROW key (3) or two number keys for the desired channel when the PRIMARY mode is active.

NOTE

If the transceiver has another mode active, the scan menu for example, two options are available to select a new channel.

3. Pressing the functions keys for the active mode returns to the PRIMARY mode with the current working channel active. Press the arrow keys or two number keys to select the desired channel. Also, in most menu display modes, pressing two number keys corresponding to a desired channel changes to the PRIMARY mode with the new channel active.



TRANSMITTING

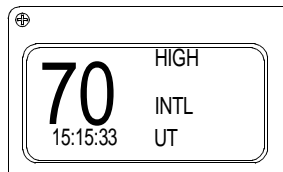
1. To transmit, hold the microphone near your lips and press the PUSH TO TALK button (10) on the microphone.
2. If a bad antenna condition is detected, the alarm message ANT FAULT appears in the lower line of the display as long as transmission is attempted. Note that the transceiver continues to attempt transmission even though the alarm message appears.

USA OR INTERNATIONAL FREQUENCIES

NOTE

The DSC may be operated on either the USA or INTERNATIONAL frequencies. The current selection appears in the PRIMARY mode display.

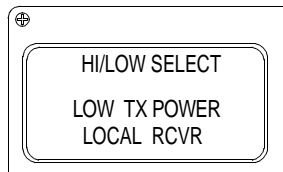
1. To change the current frequency set, press the FNC key (8) and U/I key (11) while the PRIMARY mode is active.



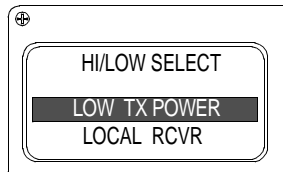
2. Press the keys to toggle annunciator between USA and INTL.

TRANSMITTER POWER SETTING

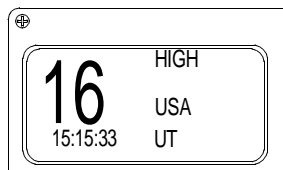
1. To change the current power setting, select the PRIMARY mode. Press the FNC key (8) and H/L key (12). The HI/LOW SELECT menu appears in the display.



2. Press the UP ARROW key (9) or DOWN ARROW key (3) to position the selection bar on TX POWER. Observe that the setting appearing in the display is the opposite of the current setting.



3. Press the ENT key (4).



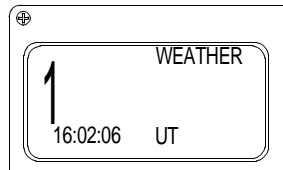
NOTE

The transmit power control for channels 13 and 67 operate differently than all others. These channels are normally low power and the power setting cannot be changed.

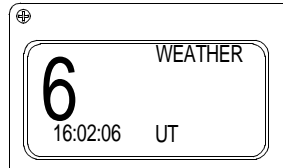
- To transmit on high power, the FNC key (8) and H/L (12) keys must be pressed and held while the microphone's PUSH TO TALK button (10) is pressed. The HIGH annunciator appears in the display while transmitting at 25 watts.

WEATHER

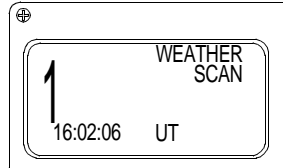
- Press the FNC key (8) and WX key (7) to receive recorded weather broadcasts. The WEATHER display will appear and the last used channel will be selected.



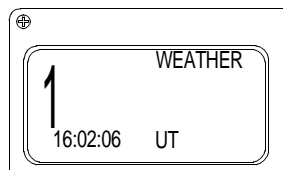
- Press the UP ARROW key (9) or DOWN ARROW key (3) or a number key to select a different weather channel.



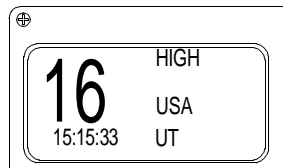
- Press the FNC key (8) and SCAN key (3) to scan all weather channels.



- Press the UP ARROW key (9) to force scanning to resume. To stop scanning and return to a weather channel, press the FNC key (8) and SCAN key (3) again.

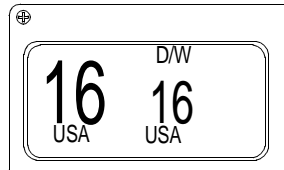


- To return to the PRIMARY mode, press the FNC key (8) and WX key (7). To select any other mode, press the function key(s) for that mode.



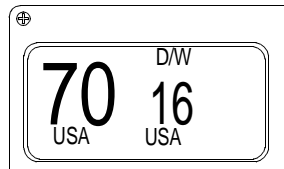
DUAL WATCH

1. Press the FNC key (8) and D/W key (9). The current working channel and last used priority channel numbers appear in the display.

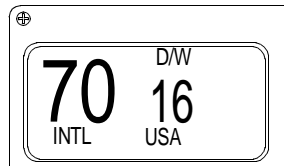
**NOTE**

The priority channel number appears in the smaller center digits of the display. The larger digits on the left of the display show the working channel. When activity is detected on the priority channel, the priority channel becomes the active channel. This will occur whether or not there is activity on the working channel. The radio will transmit only on the channel number displayed in the larger digits.

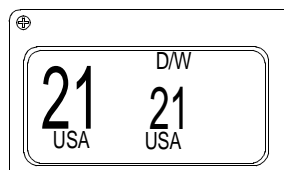
2. Pressing the PUSH TO TALK button (10) will cancel the DUAL WATCH mode.
3. To change the working channel, press the UP ARROW key (9) or DOWN ARROW key (3) or appropriate number keys to select a working channel. A three beep tone will sound if an invalid channel is selected.



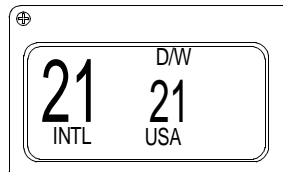
4. Press the FNC key (8) and U/I key (11) to change between USA and INTL frequencies.



5. To select or change the priority channel, press the RIGHT ARROW key (13). The smaller priority channel digits will begin flashing. The scan is halted while the digits are flashing. Press the UP ARROW key (9) or DOWN ARROW key (3) or appropriate number keys to select a priority channel.



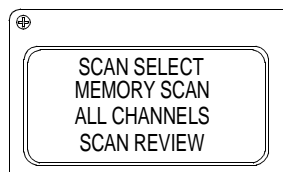
- Press the FNC key (8) and U/I key (11) to change between USA and INTL frequencies for the priority channels. Press the LEFT ARROW key (14) or RIGHT ARROW key (13) to complete the priority channel selection.



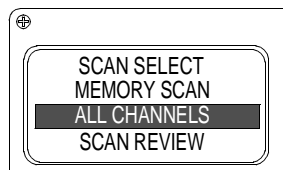
- Pressing the PUSH TO TALK button (10) on either channel will cancel the DUAL WATCH mode.
- Press the 16 key (7) to return to the PRIMARY mode.

ALL CHANNEL SCAN

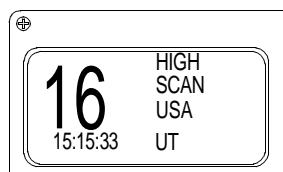
- Press the FNC key (8) and SCAN key (3). The SCAN SELECT display will appear.



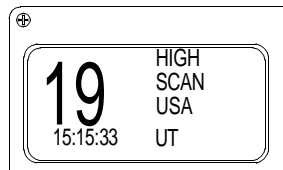
- Press the UP ARROW key (9) or DOWN ARROW key (3) to select ALL CHANNELS with selection bar.



- Press the ENT key (4) to initiate channel scanning. All channels will be scanned in sequence.



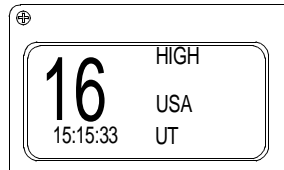
- Press the UP ARROW key (9) to override the active channel and resume scanning.



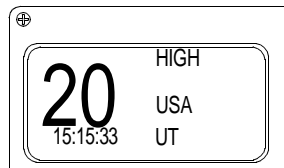
- Pressing the PUSH TO TALK button (10) or entering a channel number will cancel the ALL CHANNEL SCAN mode and select the PRIMARY mode.

SCAN MEMORY

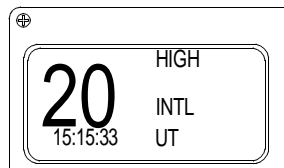
1. Press the 16 key (7) to select the calling channel. The PRIMARY mode display will appear.



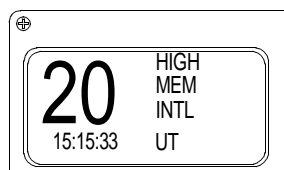
2. Press the UP ARROW key (9) or DOWN ARROW key (3) or appropriate number keys to select a desired channel.



3. Press the FNC key (8) and U/I key (11) to change between USA and INTL frequencies, if necessary.



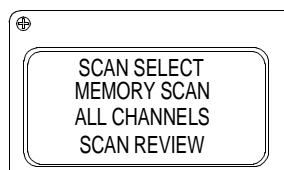
4. Press the ENT key (4) to enter the selected channel into Scan Memory. MEM will appear in the display.



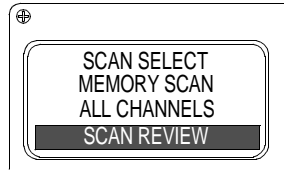
5. Press the CLR key (15) to remove a previously selected channel from SCAN MEMORY. MEM will not appear in display.

SCAN REVIEW

1. Press the FNC key (8) and SCAN key (3). The SCAN SELECT display will appear.



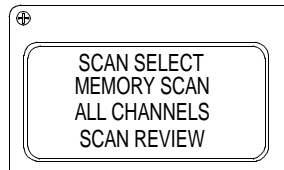
- Press the UP ARROW key (9) or DOWN ARROW key (3) to select SCAN REVIEW with selection bar.



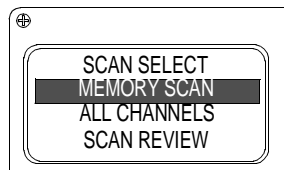
- Press the ENT key (4) to initiate SCAN REVIEW. Each channel in SCAN MEMORY will be displayed for 1 second. Two beeps will sound at the end of the list.

MEMORY SCAN

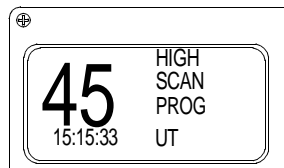
- Press the FNC key (8) and SCAN key (3). The SCAN SELECT display will appear.



- Press the UP ARROW key (9) or DOWN ARROW key (3) to select MEMORY SCAN with selection bar.



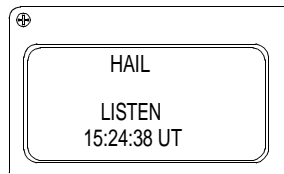
- Press the ENT key (4) to initiate scanning. Only channels previously assigned to SCAN MEMORY will be scanned. Press the UP ARROW key (9) to override an active channel and resume scanning.



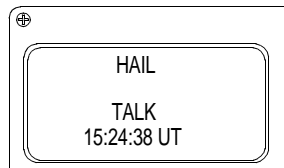
- Press the CLR key (15) while the scan is stopped on the channel this will remove an excessively active channel from SCAN MEMORY.
- Pressing the PUSH TO TALK button (10) or entering a channel number will cancel the MEMORY SCAN mode and select the PRIMARY mode. If the channel number is valid, the channel entered will be selected. If not valid, the channel being scanned at the first number key entry will become active.

HAIL

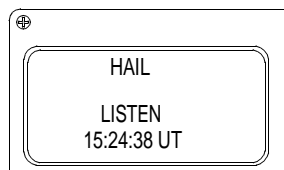
1. Press FNC/HAIL key (8) to select the HAIL mode.



2. Press the PUSH TO TALK button (10) to speak through the hail speaker. TALK will appear in the display.



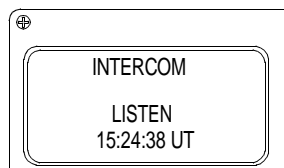
3. Release the PUSH TO TALK button (10) to listen through hail speaker. LISTEN will appear in the display.



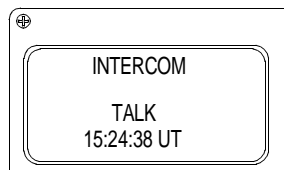
4. Use the VOL KNOB (5) to adjust the talk and listen levels. Press the FNC/HAIL key (8) again or enter a valid channel number to exit the HAIL mode and resume PRIMARY mode operation.

INTERCOM

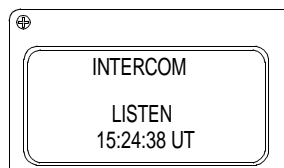
1. Press the FNC key (8) and ICM key (1) to select the INTERCOM mode. The INTERCOM display will appear.



2. Press the PUSH TO TALK button (10) to speak through the intercom speaker. TALK will appear in the display.



3. Release the PUSH TO TALK button (10) to listen through intercom speaker. LISTEN will appear in the display.



4. Use the VOL KNOB (5) to adjust the talk and listen levels. Press the FNC key (8) and ICM key (1) again or enter a valid channel number to exit the INTERCOM mode and resume PRIMARY mode operation.

Table 1. VHF Marine Channels and Frequencies.

CHAN NUMB	SIMP USA	DUP INTL	USA CHANNEL ASSIGNMENT	INTL CHANNEL ASSIGNMENT	RECEIVE (USA) FREQ. MHZ	RECEIVE (INTL) FREQ. MHZ	TRANSMIT FREQ. MHZ
01	S	D	Port Operations	Port Operations	156.050	160.650	156.050
02	S	D	Port Operations	Port Operations	156.100	160.700	156.100
03	S	D	Intership & Coast- Coast	Public Correspondence	156.150	160.750	156.150
04	S	D	Port Operations	Port Operations	156.200	160.800	156.200
05	S	D	Port Ops. (Intership/ Ship-Coast)	Port Operations	156.250	160.850	156.250
06	S	S	Ship-Ship Safety Only	Intership Safety	156.300	156.300	156.300
07	S	D	Commercial (Intership/ Ship-Coast)	Public Correspondence	156.350	160.950	156.350
08	S	S	Commercial (Intership)	Commercial	156.400	156.400	156.400
09	S	S	Comm./Non Comm. (Intership/ Ship-Coast)	Port Operations	156.450	156.450	156.450
10	S	S	Commercial (Intership/ Ship-Coast)	Port Operations	156.500	156.500	156.500
11	S	S	Commercial (Intership/ Ship-Coast)	Port Operations	156.550	156.550	156.550
12	S	S	Port Operations (Intership/ Ship-Coast)	Port Operations	156.600	156.600	156.600
13	S	S	Navigation (Ship-Ship)	Port Operations	156.650	156.650	156.650
14	S	S	Port. Ops. (Intership/ Ship-Coast)	Port Operations	156.700	156.700	156.700
15	S	S	Environmental	On-Board Communications	156.750	156.750	156.750

Table 1. VHF Marine Channels and Frequencies. (Continued)

CHAN NUMB	SIMP USA	DUP INTL	USA CHANNEL ASSIGNMENT	INTL CHANNEL ASSIGNMENT	RECEIVE (USA) FREQ. MHZ	RECEIVE (INTL) FREQ. MHZ	TRANSMIT FREQ. MHZ
16	S	S	Distress, Safety, and Calling	Distress, Safety, and Calling	156.800	156.800	156.800
17	S	S	State Control	On-Board Communications	156.850	156.850	156.850
18	S	D	Commercial (Intership/ Ship-Coast)	Port Operations	156.900	161.500	156.900
19	S	D	Commercial (Intership/ Ship-Coast)	Port Operations	156.950	161.550	156.950
20	D	D	Port Ops. (Intership/ Ship-Coast)	Port Operations	161.600	161.600	157.000
21	S	D	U. S. Government Only	Port Operations	157.050	161.650	157.050
22	S	D	Coast Guard Only	Port Operations	157.100	161.700	157.100
23	S	D	U. S. Government Only	Public Correspondence	157.150	161.750	157.150
24	D	D	Public Correspondence (Ship-Coast)	Public Correspondence	161.800	161.800	157.200
224	D	D	-	-	161.8125	161.8125	157.2125
25	D	D	Public Correspondence (Ship-Coast)	Public Correspondence	161.850	161.850	157.250
225	D	D	-	-	161.8625	161.8625	157.2625
26	D	D	Public Correspondence (Ship-Coast)	Public Correspondence	161.900	161.900	157.300
226	D	D	-	-	161.9125	161.9125	157.3025
27	D	D	Public Correspondence (Ship-Coast)	Public Correspondence	161.950	161.950	157.350
227	D	D	-	-	161.9625	161.9625	157.3625

Table 1. VHF Marine Channels and Frequencies. (Continued)

CHAN NUMB	SIMP USA	DUP INTL	USA CHANNEL ASSIGNMENT	INTL CHANNEL ASSIGNMENT	RECEIVE (USA) FREQ. MHZ	RECEIVE (INTL) FREQ. MHZ	TRANSMIT FREQ. MHZ
28	D	D	Public Correspondence (Ship-Coast)	Public Correspondence	162.000	162.000	157.400
228	D	D	-	-	162.0125	162.0125	157.4125
60	D	D	-	Port Operations	160.625	160.625	156.025
61	D	D	-	Port Operations	160.675	160.675	156.075
62	D	D	Public Correspondence	Public Correspondence	160.725	160.725	156.125
63	S	D	Port Operations	Port Operations	156.175	160.775	156.175
64	D	D	-	-	160.825	160.825	156.225
65	D	D	Port Ops. (Intership/ Ship-Coast)	Special Emergency	156.275	160.875	156.275
66	S	D	Port Ops. (Intership/ Ship-Coast)	-	156.325	160.875	156.325
67	S	S	Commercial Miss. River	Port Operations	156.375	157.375	157.375
68	S	S	Non-Commercial	Port Operations	156.425	156.425	156.425
69	S	S	Non-Commercial	Port Operations	156.475	156.475	156.475
70	S	S	Digital Selective Calling	Commercial	156.525	156.525	156.525
71	S	S	Non-Commercial	Port Operations	156.575	156.575	156.575
72	S	S	Non-Commercial	Commercial	156.625	156.625	156.625
73	S	S	Port Ops. (Intership/ Ship-Coast)	Port Operations	156.675	156.675	156.675
74	S	S	Port Ops. (Intership/ Ship-Coast)	Port Operations	156.725	156.725	156.725
75	S	S	Guard Channel	-	156.775	156.775	156.775
76	S	S	Guard Channel	-	156.825	156.825	156.825

Table 1. VHF Marine Channels and Frequencies. (Continued)

CHAN NUMB	SIMP USA	DUP INTL	USA CHANNEL ASSIGNMENT	INTL CHANNEL ASSIGNMENT	RECEIVE (USA) FREQ. MHZ	RECEIVE (INTL) FREQ. MHZ	TRANSMIT FREQ. MHZ
77	S	S	Port Ops. (Intership)	Commercial	156.875	156.875	156.875
78	S	D	Non. Commercial	Port Operations	156.925	161.525	156.925
79	S	D	Commercial	Port Operations	156.975	161.575	156.975
80	S	D	Commercial	Port Operations	157.025	161.625	157.025
81	S	D	U. S. Government Only	Port Operations	157.075	161.675	157.075
82	S	D	U. S. Government Only	Port Operations	157.125	161.725	157.125
83	S	D	U. S. Government Only	Public Correspondence	157.175	161.775	157.175
283	D	D	-	-	161.7875	161.7875	157.1875
84	S	D	U. S. Government Only	Public Correspondence	157.275	161.825	157.225
284	D	D	-	-	161.8375	161.8375	157.2375
85	D	D	Public Correspondence (Ship-Coast)	Public Correspondence	161.875	161.875	157.275
285	D	D	-	-	161.8875	161.8875	157.2875
86	D	D	Public Correspondence (Ship-Coast)	Public Correspondence	161.925	161.925	157.325
286	D	D	-	-	161.9375	161.9375	157.3375
87	D	D	Public Correspondence (Ship-Coast)	Public Correspondence	161.975	161.975	157.375
287	D	D	-	-	161.9875	161.9875	157.3875
88	S	D	Commercial (Intership)	Public Correspondence	157.425	162.025	157.425

END OF WORK PACKAGE

**OPERATOR MAINTENANCE
CAUSEWAY FERRY
VHF/FM DSC TRANSCEIVER
OPERATION UNDER USUAL CONDITIONS**

INITIAL SETUP:

Tools

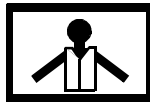
- Gloves, Men's and Women's (Leather Palm) (Item 31, WP 0105 00)
- Goggles, Sun, Wind and Dust (Safety) (Item 34, WP 0105 00)
- Life Preserver, Vest (Item 45, WP 0105 00)
- Helmet, Safety (Brown) (Item 40, WP 0105 00)

Personnel Required

Seaman 88K

**OPERATING PROCEDURES - PERFORM USER SETUPS FOR THE
VHF/FM DSC TRANSCEIVER**

WARNING



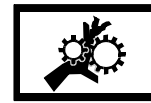
VEST



HELMET PROTECTION



HEAVY PARTS



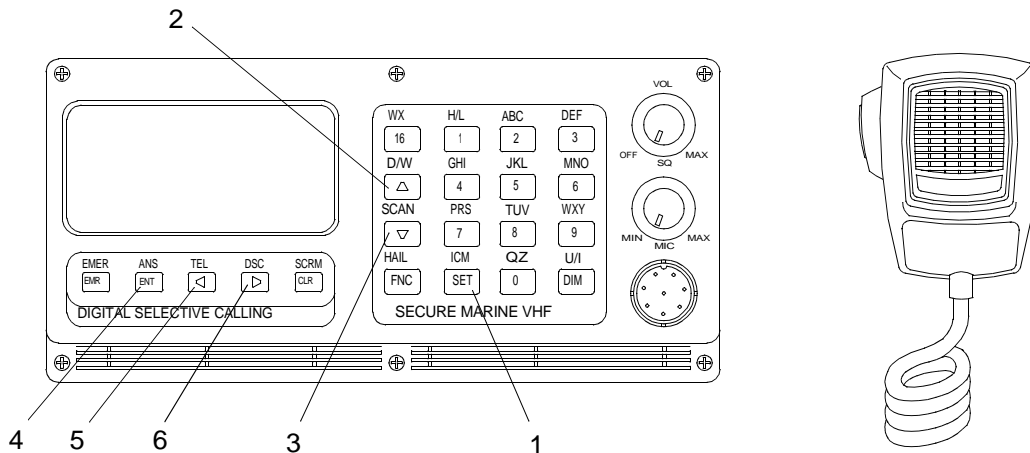
MOVING PARTS

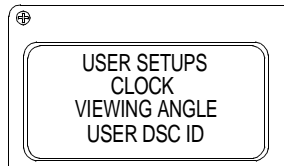
All personnel must wear personal flotation device, hard hat, safety shoes and gloves during CF operations and maintenance. Failure to observe these precautions could result in serious injury or death.

NOTE

USER SETUPS allow certain characteristics of the DSC to be set or changed according to the user's preference. Once the preferences have been set, they will be retained in memory until again changed by the user.

1. Press the SET key (1). The USER SETUPS menu will appear.





3. Press the UP ARROW key (2) or DOWN ARROW key (3) to position the selection bar on the desired selection.
4. Press the ENT key (4) to complete the selection. The appropriate setup page will appear.
5. Press LEFT ARROW key (5) or RIGHT ARROW key (6) to select the character to be changed.
6. Press the UP ARROW key (2), DOWN ARROW key (3) or a NUMBER KEY to change a value.

NOTE

If the ENT key is not pressed to complete an operation, the new setup information will not be remembered.

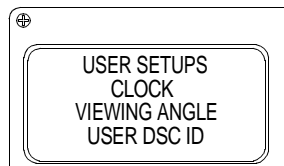
7. Press the ENT key (4) to complete the operation and return to the USER SETUPS menu.

CLOCK SETUP

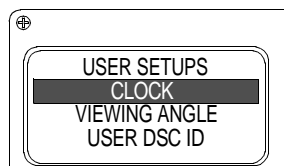
NOTE

The CLOCK SETUP page allows the user to choose how the time of day will appear in certain displays. The time may be displayed as either local time or UTC time. Local time may be displayed in AM/PM or 24 hour format. UTC time is always displayed in 24 hour format.

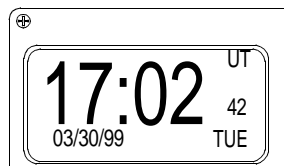
1. Press the SET key (1). The USER SETUPS menu will appear.



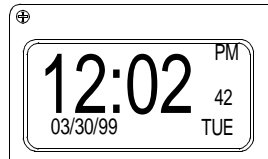
2. Press the UP ARROW key (2) to highlight CLOCK.



3. Press the ENT key (4). The CLOCK display will appear. AM or PM indicates 12 hour format, MT indicates 24 hour military format and UT indicates Universal Coordinated Time.



4. Press either the UP ARROW key (2), DOWN ARROW key (3), LEFT ARROW key (5) or RIGHT ARROW key (6) to change between AM/PM or MT or UT.

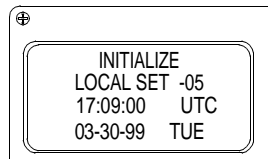


5. Press the CLR key (7). The INITIALIZE page will appear to change the time, date, day of week or local offset from UTC. The UTC time, date and day of the week appear in the lower two lines of the display. The LOCAL SET line in the display show the offset from UTC to local time as + or D the number of hours from your location to the Greenwich meridian. The + or D sign will be flashing.

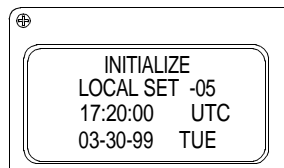
NOTE

The INITIALIZE page will appear to change the time, date, day of week or local offset from UTC. The UTC time, date and day of the week appear in the lower two lines of the display.

The LOCAL SET line in the display show the offset from UTC to local time as + or D the number of hours from your location to the Greenwich meridian. The + or D sign will be flashing.



6. Press the UP ARROW key (2) to change the sign.
7. Press the RIGHT ARROW key (6) to select the next digit in the offset field. Enter the correct number of hours. As each digit is entered, the flashing digit will move to the next position.

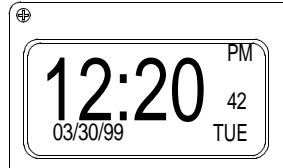


NOTE

If this is the first time you have set the clock, you may want to set the time several minutes ahead to allow for following the instructions.

8. To correct an entry, press the LEFT ARROW key (5) to backspace.
9. To skip a digit, press the RIGHT ARROW key (6). Enter the correct UTC time in hours and minutes. As each digit is entered, the flashing digit will move to the next position.
10. After the time is set, the flashing digit will move to the first digit on the lower line of the display. Press the appropriate number keys to enter the date.
11. When the date is complete, press the UP ARROW key (2) repeatedly to select the day of the week.

12. When all information is displayed correctly, press the ENT key (4).

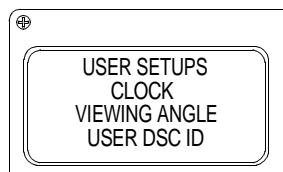


13. The UTC time will be corrected by the AN/PSN-11(V)1 PLGR if the system is operational.

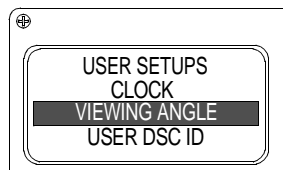
14. Press the 16 key to return to the PRIMARY mode.

VIEWING ANGLE

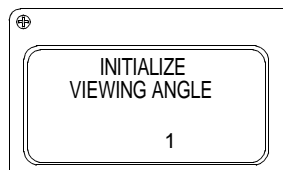
1. Press the SET key (1). The USER SETUPS menu will appear.



2. Press the UP ARROW key (2) or DOWN ARROW key (3) to select VIEWING ANGLE with the selection bar.



3. Press the ENT key (4). The INITIALIZE VIEWING ANGLE page will appear.



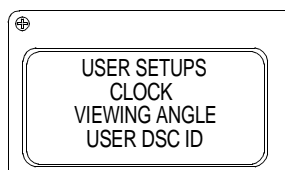
4. Press the UP ARROW key (2) or DOWN ARROW key (3) or an appropriate number key (0-7) to change the contrast between the background and the displayed character.

5. Press the ENT key (4) to complete the operation and return to the USER SETUPS menu.

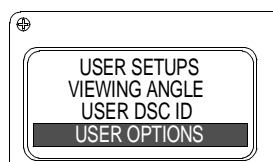
6. Press the 16 key to return to the PRIMARY mode.

USER OPTIONS

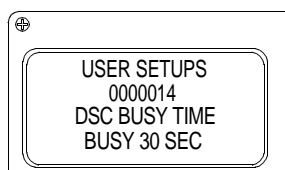
1. Press the SET key (1). The USER SETUPS menu will appear.



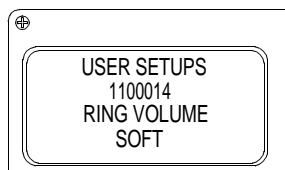
2. Press the UP ARROW key (2) or DOWN ARROW key (3) to select USER OPTIONS with the selection bar.



3. Press the ENT KEY (4), the USER OPTIONS page will appear with a seven digit number in the second line of the display.
4. Press the LEFT ARROW key (5) or RIGHT ARROW key (6) to select a digit position. The active digit position will flash.
5. Press the UP ARROW key (2) or DOWN ARROW key (3) repeatedly to change to the desired value.
6. Press the ENT key (4) to complete the operation and return to the USER SETUPS menu.
7. Press the RIGHT ARROW key (6) to select the first digit position.
8. Press the UP ARROW key (2) or DOWN ARROW key (3) repeatedly to change to the desired DSC BUSY TIME: The amount of time, after the release of the PUSH TO TALK button (8), that the transceiver will respond to a DSC call with a busy signal.



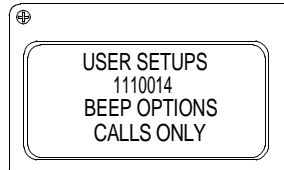
9. Press the RIGHT ARROW key (6) to select the second digit position.



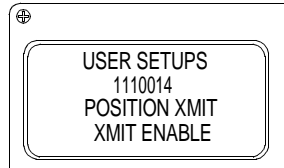
10. Press the UP ARROW key (2) or DOWN ARROW key (3) repeatedly to change to the desired ring volume.
11. Press the RIGHT ARROW key (6) to select the third digit position. Press the UP ARROW key (2) or DOWN ARROW key (3) repeatedly to change to ALL ON, CALLS ONLY or ALL OFF. The distress signal will sound with any option.

NOTE

If a distress signal is sent, position coordinates will be transmitted with either option selected, provided the AN/PSN-11(V)1 PLGR is operational.



12. Press the RIGHT ARROW key (6) to select the fourth digit position.

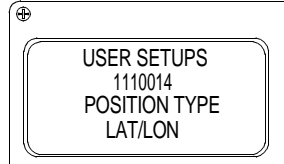


13. Press the UP ARROW key (2) or DOWN ARROW key (3) repeatedly to select POSITION XMIT or XMIT ENABLE.

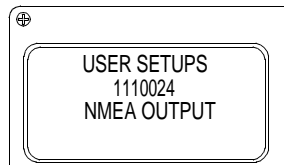
NOTE

LATITUDE/LONGITUDE should always be selected in the fifth position of the USER SETUP menu.

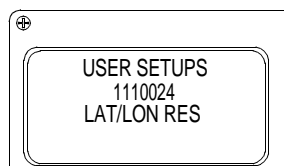
14. Press the RIGHT ARROW key (6) to select the fifth digit position.



15. Press the UP ARROW key (2) or DOWN ARROW key (3) repeatedly to select LATITUDE/LONGITUDE.
16. Press the RIGHT ARROW key (6) to select the sixth digit position.



17. Press the UP ARROW key (2) or DOWN ARROW key (3) repeatedly to select NMEA output sentences available from the data interface.
18. Press the RIGHT ARROW key (6) to select the seventh digit position.



19. Press the UP ARROW key (2) or DOWN ARROW key (3) repeatedly to select LAT/LON RESOLUTION to set the number of decimal places in LAT/LON position.

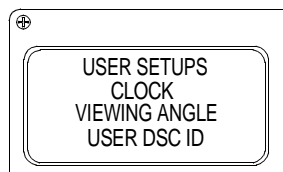
20. Press the 16 key to return to the PRIMARY mode.

COVERT MODE

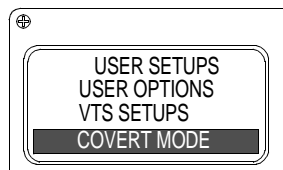
NOTE

Only military specification transceivers are equipped with the COVERT mode option.

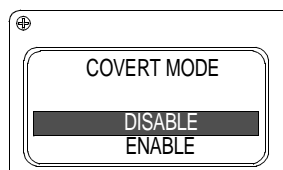
1. The COVERT mode, when enabled, prevents the DSC transceiver from being interrogated by another vessel requesting position.
2. Press the SET key (1). The USER SETUPS menu will appear.



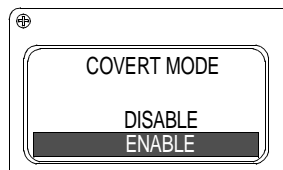
3. Press the DOWN ARROW key (3) to select COVERT mode with the selection bar.



4. Press the ENT key (4), the COVERT mode page will appear.



5. Press the DOWN ARROW key (3) to select ENABLE.

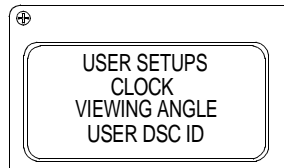


6. Press the ENT key (4). The display returns to the USER SETUPS menu.
7. Press the 16 key to return to the PRIMARY mode.

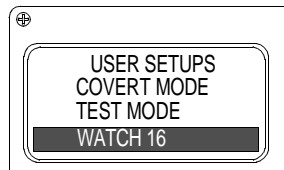
WATCH 16**NOTE**

The WATCH 16 mode, when enabled, allows the operator to select a working channel other than channel 16 while monitoring channel 16. Any activity on channel 16 will cause the transceiver to change to channel 16 until the activity ceases. The transceiver then changes back to the operator assigned working channel.

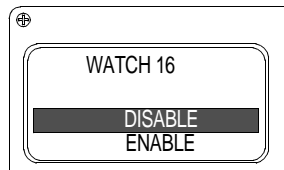
1. Press the SET key (1). The USER SETUPS menu will appear.



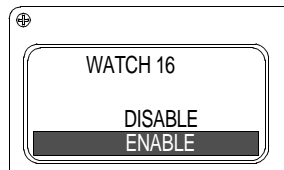
2. Press the DOWN ARROW key (3) to select WATCH 16 with the selection bar.



3. Press the ENT key (4), the WATCH 16 page will appear.



4. Press the DOWN ARROW key (3) to select ENABLE.

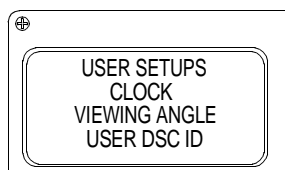


5. Press the ENT key (4). The display returns to the USER SETUPS menu.
6. Press the 16 key to return to the PRIMARY mode.

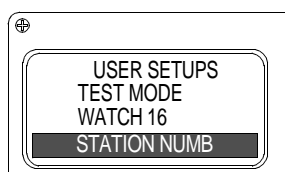
STATION NUMBER**NOTE**

Only transceivers manufactured to military specification have the STATION NUMBER mode.

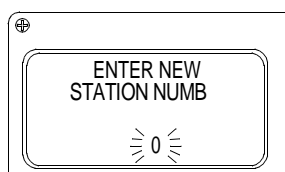
1. Press the SET key (1). The USER SETUPS menu will appear.



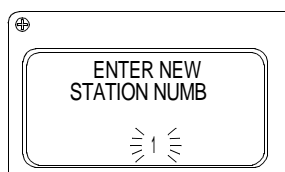
2. Press the DOWN ARROW key (3) to select STATION NUMB with the selection bar.



3. Press the ENT key (4), the STATION NUMB page will appear.



4. Enter the preferred STATION NUMBER.

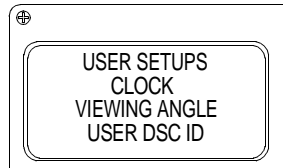


5. Press the ENT key (4). The display returns to the USER SETUPS menu.
6. Press the 16 key to return to the PRIMARY mode.

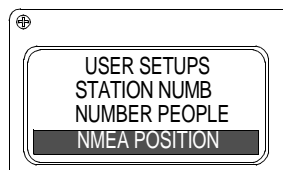
NMEA POSITION
NOTE

The NMEA POSITION function displays the position coordinates from the AN/PSN-11(V)1 PLGR.

1. Press the SET key (1). The USER SETUPS menu will appear.

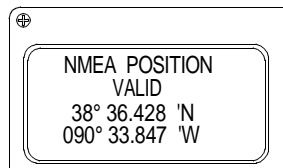


2. Press the UP ARROW key (2) or DOWN ARROW key (3) to select NMEA POSITION with the selection bar.

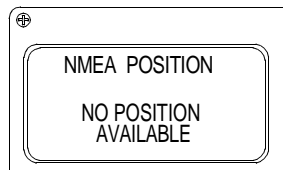
**NOTE**

The DSC protocol specifies LAT./LON coordinates for reporting. The DSC is capable of using both TD and LAT./LON coordinates, depending upon the POSITION TYPE setting on the USER OPTIONS page. Ensure that POSITION TYPE is set up for LAT./LON.

3. Press the ENT key (4). The NMEA POSITION page will appear. If position information is available from the AN/PSN-11(V)1 PLGR, the coordinates will appear.

**NOTE**

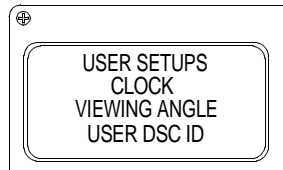
If position information is not available from AN/PSN-11(V)1 PLGR, NO POSITION AVAILABLE will appear in the lower two lines of the display.



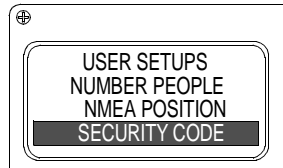
4. Press the 16 key to return to the PRIMARY mode.

SECURITY CODE

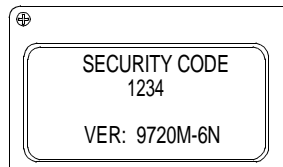
1. Press the SET key (1). The USER SETUPS menu will appear.



2. Press the UP ARROW key (2) or DOWN ARROW key (3) to select SECURITY CODE with the selection bar.

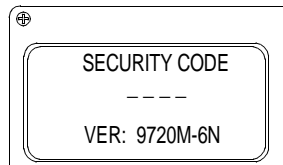


3. Press the ENT key (4). The SECURITY page will appear.

**NOTE**

Four dashes appear on the second line of the display if no code has been entered. The software version number, VER: #-#, appears in the lower line of the display. If a four digit number appears in the second line, it may be changed or deleted or left as is.

4. Press the CLR key (7) twice to clear an existing entry. Four dashes will appear in the display. To change an existing code or enter a new one, press the desired number keys. Four digits without spaces must be entered.



5. To correct an entry, press the LEFT ARROW key (5) to backspace. To skip a digit, press the RIGHT ARROW key (6).

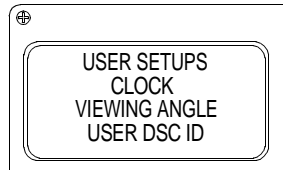
NOTE

When all information is displayed correctly, record the code number in a safe place. The next time the transceiver is turned on, you must know the code. If a security code is entered and not remembered, the transceiver's advanced features will not function. Contact a Ross Dealer or Ross Engineering Co. to restore the unit to full operation.

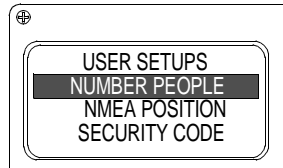
6. Press the ENT key (4) to complete the operation and return to the USER SETUPS menu.
7. Press the 16 key to return to the PRIMARY mode.

NUMBER OF PEOPLE

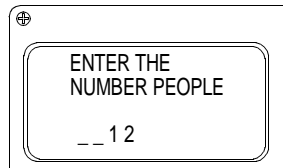
1. Press the SET key (1). The USER SETUPS menu will appear.



2. Press the UP ARROW key (2) or DOWN ARROW key (3) to select NUMBER PEOPLE with the selection bar and press the ENT key (4).



3. Enter the number of people using the digit keys on the keypad, press the ENT key (4) to save the information. This option is saved when the unit is turned off as with all USER SETUPS option.



4. Press the 16 key to return to the PRIMARY mode.

END OF WORK PACKAGE

**OPERATOR MAINTENANCE
CAUSEWAY FERRY
VHF/FM DSC TRANSCEIVER
OPERATION UNDER USUAL CONDITIONS**

INITIAL SETUP:

Tools

- Gloves, Men's and Women's (Leather Palm) (Item 31, WP 0105 00)
- Goggles, Sun, Wind and Dust (Safety) (Item 34, WP 0105 00)
- Life Preserver, Vest (Item 45, WP 0105 00)
- Helmet, Safety (Brown) (Item 40, WP 0105 00)

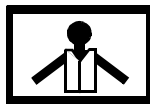
Personnel Required

Seaman 88K

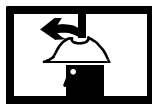
**OPERATING PROCEDURES - OPERATE THE DSC FUNCTIONS FOR THE
VHF/FM DSC TRANSCEIVER**

DSC MODE MENU ARRANGEMENT

WARNING



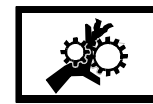
VEST



HELMET PROTECTION



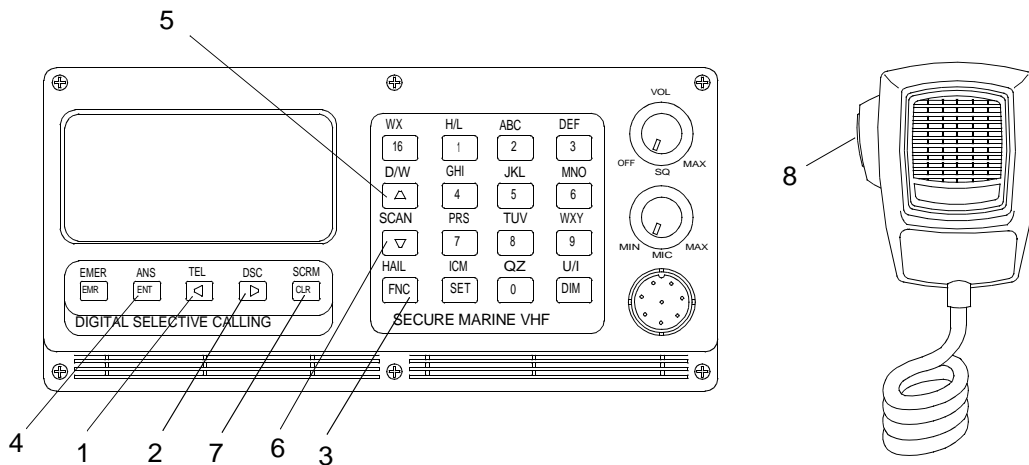
HEAVY PARTS



MOVING PARTS

All personnel must wear personal flotation device, hard hat, safety shoes and gloves during CF operations and maintenance. Failure to observe these precautions could result in serious injury or death.

1. Access the DSC mode.



2. Press the LEFT ARROW key (1) to access the desired menu; DSC CALLING, DSC STANDBY, ALL SHIPS, DISTRESS DATA, GROUP POSITION, GROUP CALLING, REQUEST POSITION and SEND POSITION.
3. Press the RIGHT ARROW key (2) to scroll through the menus and their data pages.

- Press the LEFT ARROW key (1) to scrolls through the DSC functions menu.

NOTE

When certain selections are activated, another page will appear which either presents more information or allows the user to enter information into the page.

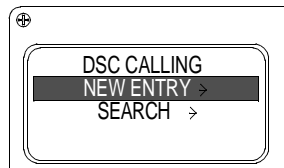
- Press the UP and DOWN ARROW keys (5, 6) to highlight the desired selection with the menu bar.

DSC CALLING DIRECTORY

NOTE

The basic procedure for entering names and numbers into directories is the same for all directories except CALL WAITING and DISTRESS DATA. These two directories automatically receive DSC calls and do not accept user entries from the keypad. However, logged entries may be cleared as desired from the CALL WAITING directory. The contents of all directories are protected from loss by an internal memory battery.

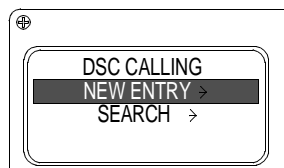
- Press the FNC key (3) and DSC (2) keys to access the DSC CALLING directory. The DSC CALLING menu will appear in the display.



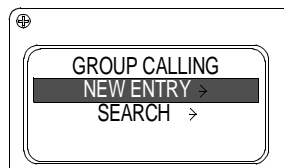
- Select NEW ENTRY or SEARCH.

DSC GROUP CALLING DIRECTORY

- Press the FNC key (3) and DSC (2) keys to access the DSC GROUP CALLING directory. The DSC CALLING menu will appear in the display.



- Press the RIGHT ARROW key (2) repeatedly until the GROUP CALLING menu is displayed.



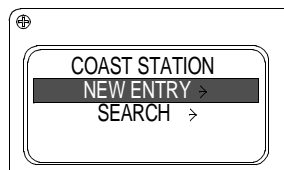
DSC COAST STATION DIRECTORY**NOTE**

The DSC COAST STATION directory will accept 50 entries of station names and their ID numbers. The name may be one to ten characters and the ID number must be nine digits. Letters, numbers and spaces may be used in the name but at least one character must be entered. An ID number without a name will not be accepted.

1. To access the DSC COAST STATION directory, press the FNC key (3) and TEL key (1). The TELEPHONE menu will appear in the display.



2. Press the RIGHT ARROW key (2). The COAST STATION menu will appear in the display.

**DSC TELEPHONE DIRECTORY****NOTE**

The DSC TELEPHONE directory will accept 200 entries of individual names and their telephone numbers. The telephone number may be up to 16 digits long, while the name may not exceed 10 characters. Letters, numbers and spaces may be used in the name but at least one character must be entered. A telephone number without a name will not be accepted. Letters are not accepted in telephone numbers.

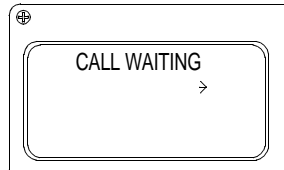
1. Press the FNC key (3) and TEL key (1) to access the DSC TELEPHONE directory. The TELEPHONE menu will appear in the display.



2. Select NEW ENTRY or SEARCH.

DSC CALL WAITING DIRECTORY

1. Press the FNC key (3) and ANS key (4) to access the DSC CALL WAITING directory. The CALL WAITING menu will appear in the display.



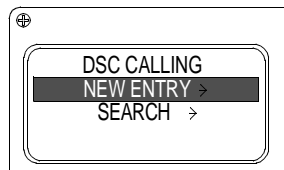
2. Select the call to be returned.

BUILDING DIRECTORIES

1. Press the FNC key (3) and TEL key (1) to select the TELEPHONE mode.



2. Access the DSC calling or group calling directories entering the DSC mode.



3. Press the FNC key (3) and DSC key (2). When the desired mode is active, press the RIGHT ARROW key (2) to select the desired entry.
4. Press the UP ARROW key (5) or DOWN ARROW key (6) to position the selection bar on NEW ENTRY. Press the ENT key (4).

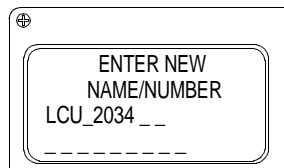
NOTE

The ENTER NEW NAME/NUMBER page will appear. Dashes will appear in the lower two lines of the display.

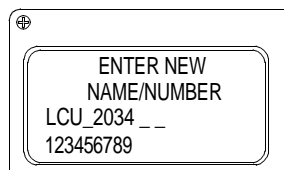


A name must be entered on the second line from the bottom of the display and the ID number must be entered on the lower line. A name may be one or more alphanumeric characters but the ID number must be nine digits. Alphabetic entries are allowed only on certain pages for entering names into directories. At other times, pressing a number key will enter a numeric value only.

- To enter a letter into the name line of the display, press the appropriate number key until the desired letter or the number appears in the character position.



- Press the next key to be entered and the entry point will move to the next position automatically.
- Press the RIGHT ARROW key (6) to move the entry point to the next character position if more than one letter from the same key must be entered in succession.
- Press the LEFT ARROW key (5) to backspace and correct an entry if necessary.
- Press the DOWN ARROW key (3) to move the entry point to the ID number line when the name is complete.
- Press the appropriate number keys to enter the Ship Station Identification number. To correct an entry, press the LEFT ARROW key (1) to backspace. To skip a digit, press the RIGHT ARROW key (2).



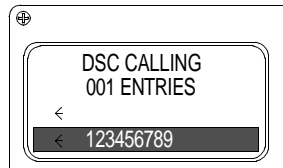
- When all information is displayed correctly, press the ENT key (4) to complete the operation.



NOTE

The DSC CALLING menu will appear and the newest entry name will appear with the selection bar in the lower line of the display

12. To check the ID number for the name, press the RIGHT ARROW key (2). The corresponding ID number will appear with the selection bar in the lower line of the display. To return to the name, press the LEFT ARROW key (1).



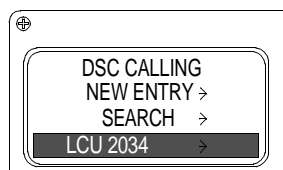
13. Use the LEFT ARROW (1) and RIGHT ARROW (2) keys to switch back and forth between a name page and a number page.
14. Press the UP ARROW key (5) and DOWN ARROW key (6) as appropriate to recall other names and numbers in the directory.
15. Press and hold down the appropriate ARROW key to scroll through the directory list.
16. Select NEW ENTRY from the menu and repeat the above entry procedure to add more entries to the directory.
17. Press the appropriate function keys again or enter a valid channel number to exit the directory and return to the PRIMARY mode.
18. Press the function keys for the desired mode to exit the directory and select another mode.

CHANGE OR REMOVE AN EXISTING DIRECTORY ENTRY

1. To access a directory, first select the appropriate mode. To access the TELEPHONE and COAST STATION directories, enter the TELEPHONE mode. Press the FNC key (3) and TEL key (1).



2. To access the DSC CALLING or GROUP CALLING directories, enter the DSC mode.



3. Press the FNC key (3) and DSC key (2).
4. Press the RIGHT ARROW key (2) as necessary to select the desired directory.

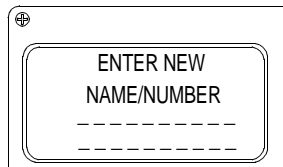
5. Press the UP ARROW key (5) or DOWN ARROW key (6) to position the selection bar on the entry you want to change or remove.



6. Press the CLR key (7). The ENTER NEW page will appear with the selected entry information displayed. The first character in the name will be flashing.
7. To remove the selection from the directory, press the CLR key (7) twice. Dashes will appear in the name line of the display.



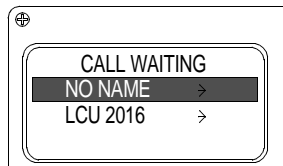
8. Press the ENT key (4). Both the name and ID number have been cleared from the directory.



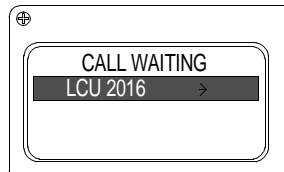
9. Change the name or ID number.
 - a. Press the UP ARROW key (5), DOWN ARROW key (6), LEFT ARROW key (1) or RIGHT ARROW key (2) to move the flashing entry point to the character to be changed.
 - b. Press the appropriate number keys to make the desired changes.
 - c. When all information is displayed correctly, press the ENT key (4) to complete the operation and enter the changes into the directory.

TRANSFER OR CLEAR FROM CALL WAITING

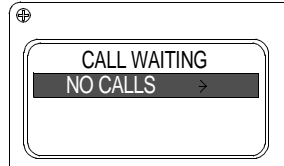
1. Press the FNC key (3) and ANS key (4) to access the DSC CALL WAITING directory. The CALL WAITING menu will appear in the display.



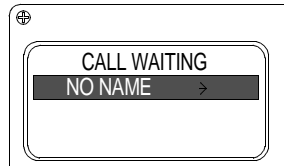
2. Press the UP ARROW key (5) or DOWN ARROW key (6) to position the selection bar on the entry you want to transfer or clear. If the selection has a name and you want to remove it from the directory, press and hold the CLR key (7) for two seconds. The selection will be cleared and the next entry in the directory will appear with the selection bar.



3. If no more entries exist in the directory, NO CALLS will appear in the display.

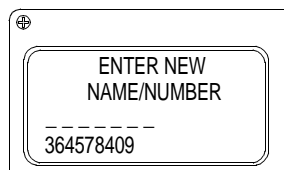


4. If the selection is NO NAME, press and hold the CLR key (7) for two seconds.



NOTE

The ENTER NEW NAME/NUMBER page will appear. The ID number will appear in the lower line of the display and dashes will appear in the line above the ID number. The first dash will be flashing.

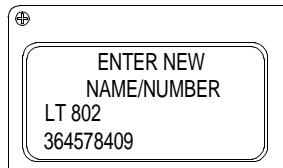


5. Press the ENT key (4) to clear the entry. The entry is cleared.

NOTE

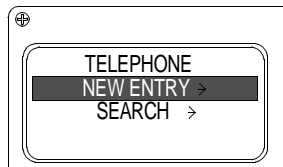
A name must be entered in order to transfer the selected entry. A name may be one or more letters or numbers and may include spaces. At least one character must be entered. Names are entered by pressing the number key that is associated with the letters of the alphabet printed above them. The number for that key may be used as part of the name also.

6. Press the appropriate number keys to enter a name. When all information is displayed correctly, press the ENT key (4). The new name and its corresponding ID number have been added to the DSC calling directory also.

**SEARCHING DIRECTORIES****NOTE**

To search a directory, first select the appropriate mode.

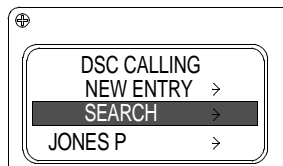
1. Press the FNC key (3) and TEL key (1) to access the TELEPHONE and COAST STATION directories.



2. Press the FNC key (3) and DSC key (2) to access the DSC CALLING and GROUP CALLING directories.

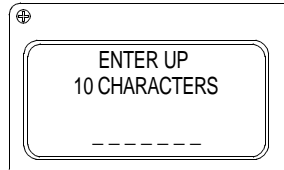


3. Press the RIGHT ARROW key (2) as necessary to select the desired directory.

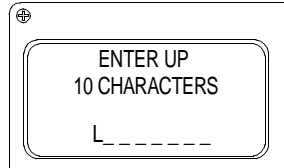


4. Press the UP ARROW key (5) or DOWN ARROW key (6) to position the selection bar on SEARCH in the DIRECTORY menu.

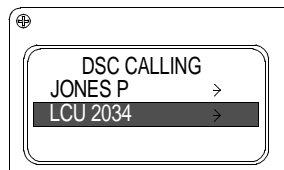
5. Press the ENT key (4).



6. Press the appropriate key to enter one or more characters of the name to be found.



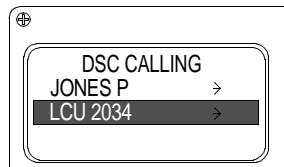
7. Press the ENT key (4) to complete the operation. The name alphabetically nearest to the search character(s) will appear in the display with the selection bar.



8. Press the UP ARROW key (5) or DOWN ARROW key (6) to position the selection bar on another entry if necessary. Once the desired entry is found, any appropriate function may be activated using the entry.

PLACING A DSC INDIVIDUAL CALL

1. Select the PRIMARY mode by exiting any other active function. Press the appropriate number keys to select the desired working channel. A three beep tone will sound if an invalid channel number is entered. Press the FNC key (3) and DSC key (2). The DSC calling menu will appear in the display.



NOTE

One of four status messages will appear when placing a call. These status messages are:

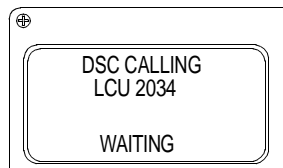
ANSWERED. Contact with the called vessel was established. After several seconds, the transceiver will switch to the PRIMARY mode and the selected working channel will be active. Normal communications may begin immediately. The called party's name will appear in the lower line of the display. The time of day will return to the lower line of the display after 1 minute.

NO RESPONSE. Contact with the other vessel could not be established. After several seconds, the DSC calling directory will reappear with the called party's name at the top of the list. You may call again later or select another party to call.

BUSY. Contact was established but the transceiver was busy. Your call will be logged into the other transceiver's call waiting directory. After several seconds, the DSC calling directory will reappear with the called party's name at the top of the list. You may call again later or select another party to call.

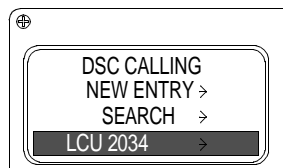
UNATTENDED. Contact was established with the other vessel. The other vessel's transceiver is set to reply with the unattended message. For some reason an operator is not available to respond. Your call will be logged into the other transceiver's call waiting directory. After several seconds, your DSC calling directory will reappear with the called party's name at the top of the list. You may call again later or select another party to call.

2. Press the UP ARROW key (5) or DOWN ARROW key (6) to select the desired party from the directory. A three or four beep tone will sound and a status message will appear in the display.
3. Press the ENT key (4) to initiate the call. The called party's name and WAITING will appear in the display.



PLACING A DSC GROUP CALL

1. Select the PRIMARY mode by exiting any other active function. Press the appropriate number keys to select the desired working channel. A three beep tone will sound if an invalid channel number is entered.
2. Press the FNC (3) and DSC (2) keys. The DSC CALLING menu will appear in the display.



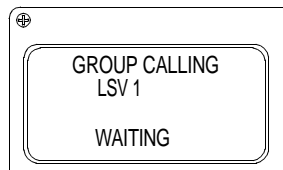
3. Press the RIGHT ARROW key (2) repeatedly until the GROUP CALLING menu appears. Press the DOWN ARROW key (6) to highlight the desired group name.



NOTE

On group calls, there is no acknowledgement from the called vessels. After several seconds, the transceiver switches to the PRIMARY mode and the selected working channel is active. The group name will appear in the lower line of the display. Normal communication may begin immediately and a voice poll or roll call should be made to confirm which group members are present. The time of day will return to the lower line of the display after 1 minute.

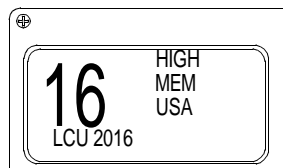
4. Press the ENT key (4) to initiate the call. The called group's name and WAITING will appear in the display.



DSC ANSWERING AND CALL WAITING

NOTE

Calls received while idle are signaled by short Hi/Lo beeps. RECEIVED DSC CALL FROM with the caller's name or DSC call sign will appear in the display for 5 seconds. The PRIMARY mode display will appear with the caller's name or DSC call sign in the lower line. The channel number displayed will be the caller's working channel. The sound will repeat every 8 seconds until the call is answered or until the call is logged into the CALL WAITING directory after 60 seconds.

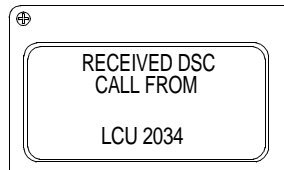


1. Press the PUSH TO TALK button (8) on the microphone and acknowledge the call verbally. To silence the beeps without answering the call, press the CLR key (7). The call will not be logged.

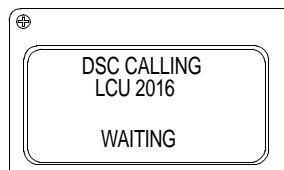
NOTE

Calls received while busy or unattended are signaled by short Hi/Lo beeps that will sound only once. The call will be logged into the CALL WAITING directory if the call is not answered within 60 seconds. The vessel that called will appear flashing in the lower line of the PRIMARY mode display. When you are able to return the call, press the appropriate number keys to select the desired working channel. A three beep tone will sound if an invalid channel number is entered.

2. Press the UP ARROW key (5) or DOWN ARROW key (6) to select the desired caller from the directory.

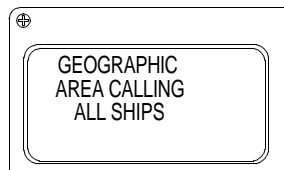


3. Press the ENT key (4) to answer the call on the current working channel of your radio. The called party's name and WAITING will appear in the display.

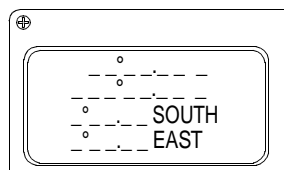


GEOGRAPHIC AREA CALLING

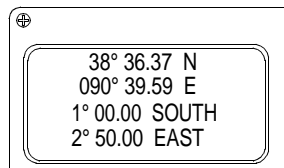
1. Access the DSC directory. Press the LEFT ARROW key (2) until the title GEOGRAPHIC AREA CALLING ALL SHIPS is displayed.



2. Press the ENT key (4) to open the edit to make a geographic area call.



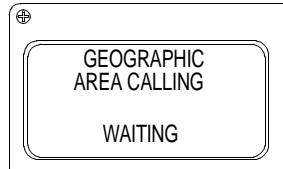
3. Enter the latitude of the reference point on line one and the longitude reference point on line two. Enter the number of degrees and minutes of the North-to-South side on line three and the West-to-East side on line four.



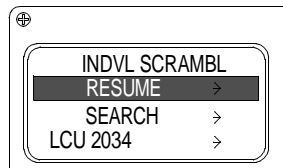
NOTE

The geographical area call will switch all vessels within the defined area to the calling radio's working channel just like a DSC GROUP CALL.

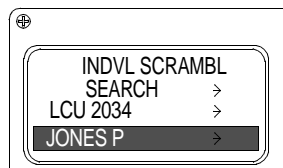
4. Press the ENT key (4) to activate the DSC call.


SCRAMBLER MODE

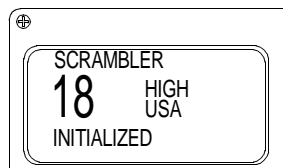
1. Place an individual scrambled call.
 - a. Select the PRIMARY mode by exiting any other active function.
 - b. Press the appropriate number keys to select the desired working channel. A three beep tone will sound if an invalid channel is selected.
 - c. Press the FNC key (3) and SCRM key (7). The INDIVIDUAL SCRAMBLER menu will appear in the display.



- d. Press the UP ARROW key (5) or DOWN ARROW key (6) to select the desired party from the directory.

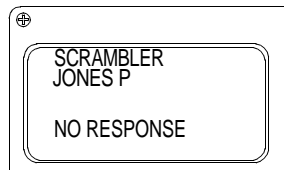


- e. Press the ENT key (4) to initiate the call. SCRAMBLER will appear in the upper line of the display and INITIALIZED will appear in the lower line. Working channel information will also be displayed.



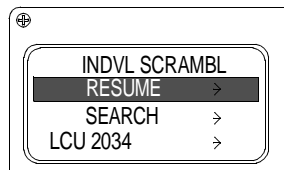
NOTE

A three or four beep tone will sound and either the called party's name or a status message will appear in the display. If the called party's name appears, the call was completed and scrambled voice communication may proceed.

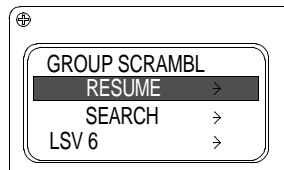


2. Place a scrambled group call.

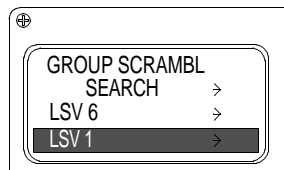
- a. Select the PRIMARY mode by exiting any other active function.
- b. Press the appropriate number keys to select the desired working channel. A three beep tone will sound if an invalid channel is selected.
- c. Press the FNC key (3) and SCRM key (7). The INDIVIDUAL SCRAMBLE menu will appear in the display.



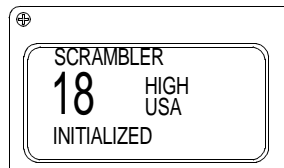
- d. Press the RIGHT ARROW key (2). The SCRAMBLER GROUP menu will appear in the display.



- e. Press the UP ARROW key (5) or DOWN ARROW key (6) to select the desired party from the directory.



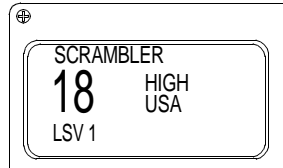
- f. Press the ENT key (4) to initiate the call. SCRAMBLER will appear in the upper line of the display and INITIALIZED will appear in the lower line. Working channel information will also be displayed.



NOTE

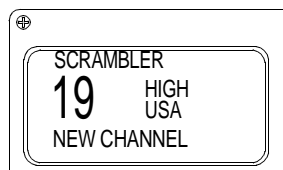
In group calls there is no acknowledgement from the called vessels. A voice poll or role call should be made to confirm which group members are present.

When the group name appears in the lower line of the display, voice contact may be initiated.

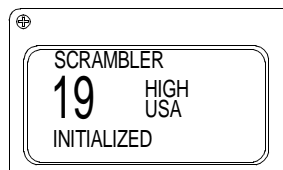


3. Change scrambler channels.

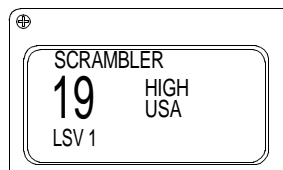
- a. Press the UP ARROW key (5) or DOWN ARROW key (6) or press the appropriate number keys to select a different working channel. A three beep tone will sound if an invalid channel is selected. NEW CHANNEL will appear in the lower line of the display.



- b. Press the ENT key (4) to complete the operation. INITIALIZED will appear in the lower line of the display.



- c. When the called party's name returns to the lower line of the display, the channel change is complete and scrambled voice contact may resume.



- d. Ensure that the PUSH TO TALK button (8) is not pressed before pressing the ENT key (4) or the SCRAMBLER mode will be cancelled and the PRIMARY mode will become active.

4. Cancel SCRAMBLE mode.

- a. Press the FNC key (3) and SCRM key (7) again or change channels and press the PUSH TO TALK button (8) instead of the ENT key (4).
- b. The SCRAMBLE mode may also be cancelled by pressing the appropriate function keys to activate another mode.

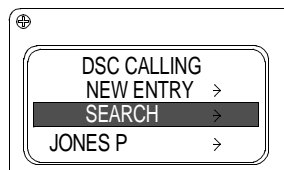
NOTE

The resume feature allows the user to interrupt scrambled conversation to use the transceiver for other communication and return to the scrambled conversation without having to initialize. The working channel and scramble codes are memorized by the transceiver. The resume feature may be used in both individual and group scramble communication.

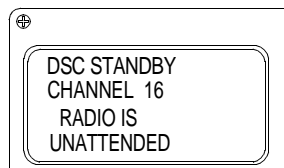
5. Resume SCRAMBLE mode.
 - a. Press the FNC key (3) and SCRM key (7) to resume a scrambled call. The scramble menu will appear.
 - b. Press the RIGHT ARROW key (2) to select GROUP.
 - c. Press the UP ARROW key (5) to select RESUME.
 - d. Press the ENT key (4). The SCRAMBLER display will appear showing the working channel and the other vessel's name.

DSC STANDBY

1. Press the appropriate number keys to select the desired channel to monitor. A three beep tone will sound if an invalid channel is selected. Press the FNC key (3) and DSC key (2). The DSC CALLING menu will appear in the display.



2. Press the LEFT ARROW key (1) two times until the DSC STANDBY menu appears. DSC STANDBY, CHANNEL number and RADIO IS UNATTENDED will appear in the display with the selected monitor channel number.

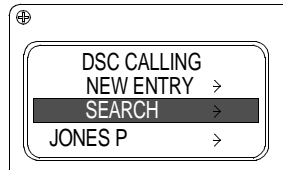
**NOTE**

When a DSC call is received, the radio will respond with the unattended message informing the caller that an operator is not available to answer the call. Calls received will be logged into the CALL WAITING directory.

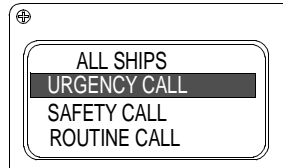
3. Enter a valid channel number or press the PUSH TO TALK button (8) to cancel the DSC STANDBY mode and switch to the PRIMARY mode.

ALL SHIPS CALL

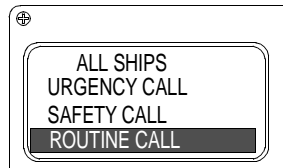
1. Press the appropriate number keys to select the desired working channel. A three beep tone will sound if an invalid channel is selected. Press the FNC key (3) and DSC key (2). The DSC CALLING menu will appear in the display.



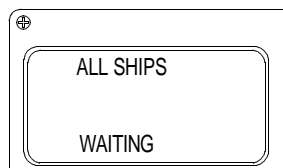
2. Press the RIGHT ARROW key (2) repeatedly until ALL SHIPS menu appears.



3. Press the UP ARROW key (5) or DOWN ARROW key (6) to select the priority for the call.



4. Press the ENT key (4) to initiate the ALL SHIPS call. DSC transceivers aboard vessels receiving the call will ring and ALL SHIPS will appear in their display.



5. The vessel initiating a all ships call should make a voice call to alert the other vessels.

SENDING POSITION

WARNING

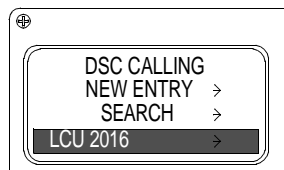
During tactical operations, any vessel can request position through the VHF/FM DSC transceiver. There is no request authorization required nor can this request be seen by the vessel operator. During tactical operations, switches SW1, SW2, SW3 on the AN/PSN-11 interface and switchbox should remain in the OFF position and used only as necessary to prevent unwanted interrogation of position for vessels equipped with a DSC transceiver not manufactured to military specification. Vessels operating with a DSC transceiver manufactured to military specification may leave switch SW3 on the AN/PSN-11 interface and switchbox in the on position but must operate with the COVERT mode enabled. Failure to comply during tactical operations could result in injury or death to personnel.

NOTE

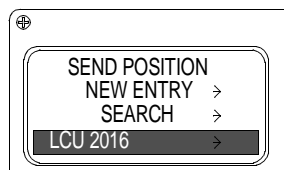
The send position function will override the POSITION XMIT DISABLE.

The type of position coordinates sent, either Lat./Lon or Loran TD's is determined by the POSITION TYPE USER OPTION in the USER SETUPS mode.

1. To send the current position, press the FNC (3) and DSC (2) keys. The DSC CALLING menu will appear in the display.



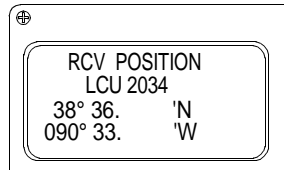
2. Press the RIGHT ARROW key (2) repeatedly until the END POSITION menu appears.



3. Press the UP ARROW key (5) or DOWN ARROW key (6) to select the desired name from the directory. Press the ENT key (4) to initiate the call. There is no acknowledgement from the other vessel that the position was received.

RECEIVE A POSITION

1. Be alert for four beeps that will sound when a SEND POSITION call is received from another vessel. RCV POSITION will appear in the upper line of the display.

**NOTE**

The calling vessel's name or Ship Station Identity number will appear in the second line and the calling vessel's coordinates will appear in the lower two lines of the display. At the same time as the position coordinates are displayed, the position information is output through the data interface. The interface may be connected to any device capable of receiving the information.

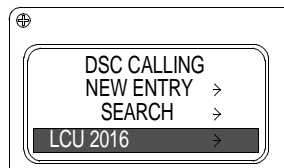
2. Press the ENT key (4) if the receiving device was not ready to accept the data. Each time the key is pressed, the position coordinated will be output to the data interface.
3. The display will remain until a valid channel number is entered or the PUSH TO TALK button (8) is pressed or another function is selected.

REQUEST POSITION

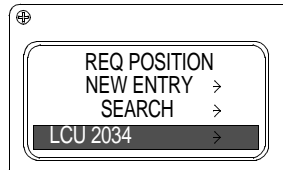
WARNING

During tactical operations, any vessel can request position through the VHF/FM DSC transceiver. There is no request authorization required nor can this request be seen by the vessel operator. During tactical operations, switches SW1, SW2, SW3 on the AN/PSN-11 interface and switchbox should remain in the OFF position and used only as necessary to prevent unwanted interrogation of position for vessels equipped with a DSC transceiver not manufactured to military specification. Vessels operating with a DSC transceiver manufactured to military specification may leave switch SW3 on the AN/PSN-11 interface and switchbox in the on position but must operate with the COVERT mode enabled. Failure to comply during tactical operations could result in injury or death to personnel.

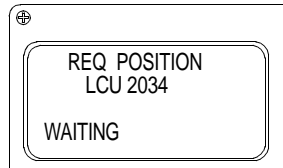
1. Press the FNC key (3) and DSC (2) key to request the position of another vessel. The DSC CALLING menu will appear in the display.



- Press the RIGHT ARROW key (2) repeatedly until the REQ POSITION menu appears.



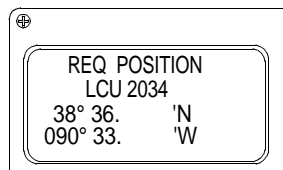
- Press the UP ARROW key (5) or DOWN ARROW key (6) to select the desired name from the directory.



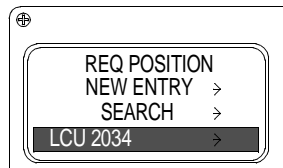
- Press the ENT (4) key to initiate the call. The called vessel's name and WAITING will appear in the display.

NOTE

Three or four beeps will sound and either the called vessel's coordinates or a status message will appear in the display.



- Press the ENT key (4) if the receiving device was not ready to accept the data. Each time the key is pressed, the position coordinates will be output to the data interface.
- To return to the REQUEST POSITION menu, press the CLR key (7).



- To return to the PRIMARY mode, enter a valid channel number, press the PUSH TO TALK button (8) or select another mode by pressing the appropriate function keys.

END OF WORK PACKAGE

**OPERATOR MAINTENANCE
CAUSEWAY FERRY
PRECISION LIGHTWEIGHT GLOBAL POSITIONING RECEIVER (PLGR)
OPERATION UNDER USUAL CONDITIONS**

INITIAL SETUP:**Tools**

Gloves, Men's and Women's (Leather Palm) (Item 31, WP 0105 00)
Goggles, Sun, Wind and Dust (Safety) (Item 34, WP 0105 00)
Life Preserver, Vest (Item 45, WP 0105 00)
Helmet, Safety (Brown) (Item 40, WP 0105 00)

Personnel Required

Seaman 88K

References

TM 11-5825-291-13

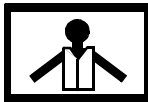
Equipment Condition

Interface And Switchbox Power On. (WP 0022 00)

OPERATING PROCEDURES - PERFORM INITIAL SETUP OF THE PRECISION LIGHTWEIGHT GLOBAL POSITIONING RECEIVER (PLGR)

SETUP PLGR

WARNING



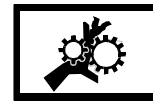
VEST



HELMET PROTECTION



HEAVY PARTS

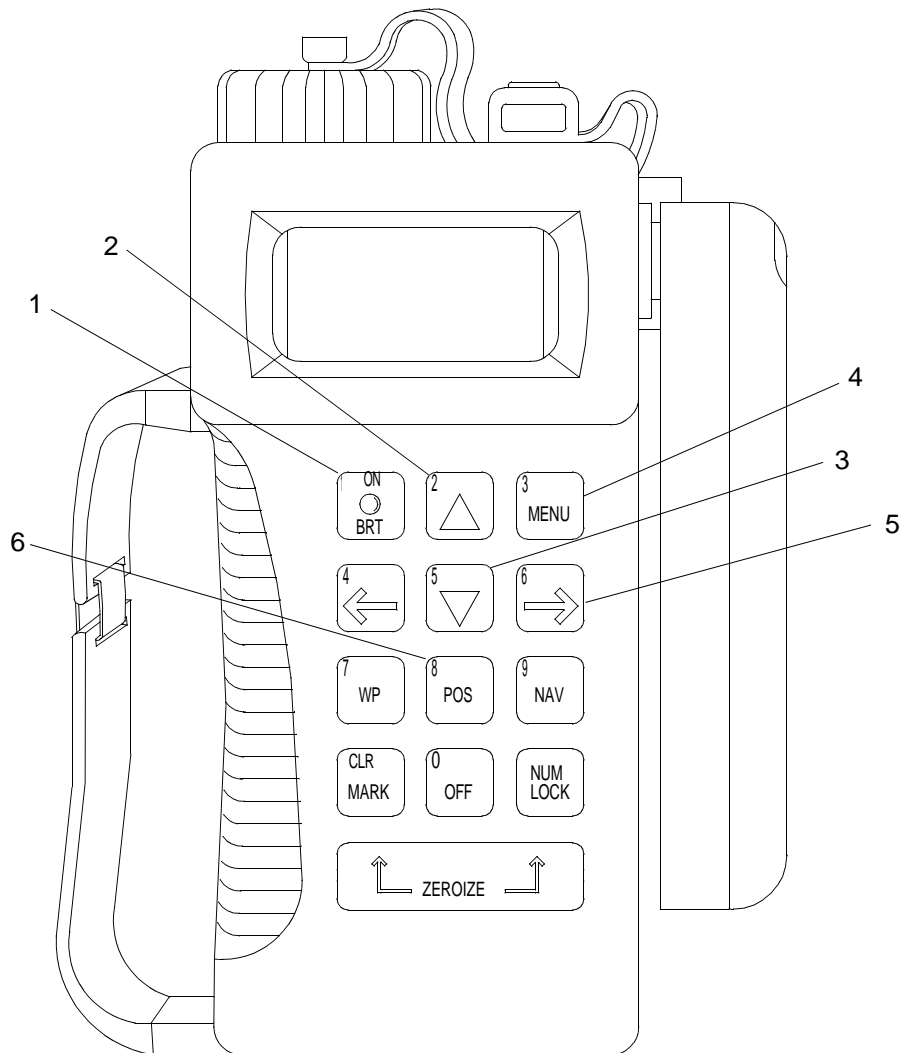


MOVING PARTS

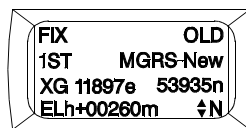
All personnel must wear personal flotation device, hard hat, safety shoes and gloves during CF operations and maintenance. Failure to observe these precautions could result in serious injury or death.

To prevent personal injury and equipment damage, remove BA-5800 battery before applying external power.

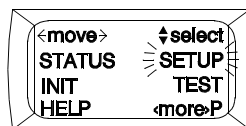
1. Press the ON key (1) to turn the PLGR on.



2. Adjust the display backlighting by simultaneously pressing the ON/BRT key (1) and the UP ARROW key (2) to increase lighting or the DOWN ARROW key (3) to decrease lighting.

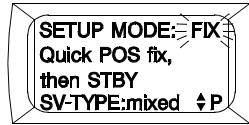


3. Press the MENU key (4).
4. Ensure SETUP is flashing. If STATUS is flashing, press the RIGHT ARROW key (5).

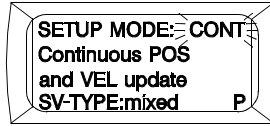


5. Press the DOWN ARROW key (3).

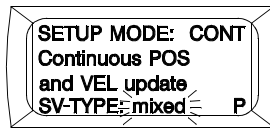
- Press the RIGHT ARROW key (5). Ensure that FIX is flashing in SETUP mode.



- Press the UP ARROW key (2) or DOWN ARROW key (3) until CONT is flashing in SETUP mode.



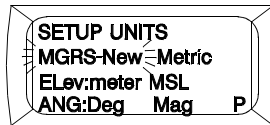
- Press the RIGHT ARROW key (5) to save CONT and move to next selection.
- Press the UP ARROW key (2) or DOWN ARROW key (3) until MIXED is flashing in SV-TYPE.



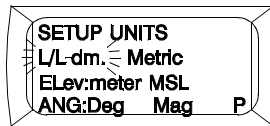
- Press the RIGHT ARROW key (5) to save MIXED.

SETUP UNITS

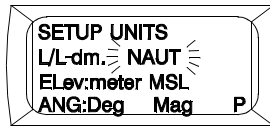
- Press the DOWN ARROW key (3) to advance to SETUP UNITS.
- Press the RIGHT ARROW key (5) to start selection flashing.



- Press the UP ARROW key (2) or DOWN ARROW key (3) until L/L-DM. is flashing.

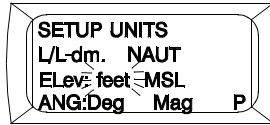


- Press the RIGHT ARROW key (5) to save L/L-DM. and move to next selection.
- Press the UP ARROW key (2) or DOWN ARROW key (3) until NAUT is flashing.

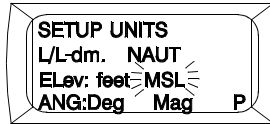


- Press the RIGHT ARROW key (5) to save NAUT and move to next selection.

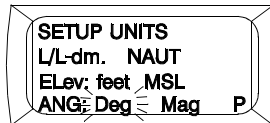
7. Press the UP ARROW key (2) or DOWN ARROW key (3) until FEET is flashing for ELEV.



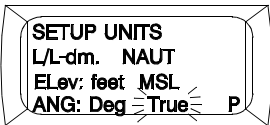
8. Press the RIGHT ARROW key (5) to save FEET and move to next selection.
9. Press the UP ARROW key (2) or DOWN ARROW key (3) until MSL is flashing.



10. Press the RIGHT ARROW key (5) to save MSL and move to next selection.
11. Press the UP ARROW key (2) or DOWN ARROW key (3) until DEG is flashing for ANG.

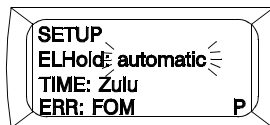


12. Press the RIGHT ARROW key (5) to save DEG and move to next selection.
13. Press the UP ARROW key (2) or DOWN ARROW key (3) until TRUE is flashing for vessels with a gyro compass. For vessels without a gyro compass, select MAG.

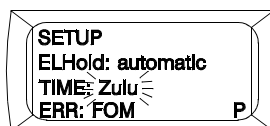


SETUP ELHOLD, TIME AND ERR

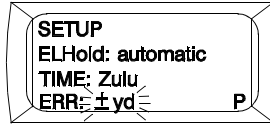
1. Press the DOWN ARROW key (3) twice to advance to SETUP.
2. Press the RIGHT ARROW key (5) to start selection flashing.
3. Press the UP ARROW key (2) or DOWN ARROW key (3) until automatic is flashing for ELHOLD.



4. Press the RIGHT ARROW key (5) to save AUTOMATIC and move to next selection.
5. Press the UP ARROW key (2) or DOWN ARROW key (3) until ZULU is flashing for TIME.



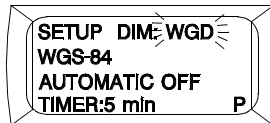
6. Press the UP ARROW key (2) or DOWN ARROW key (3) to save ZULU and move to next selection.
7. Press the UP ARROW key (2) or DOWN ARROW key (3) until ± YD is flashing for ERR.



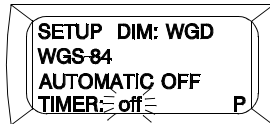
8. Press the RIGHT ARROW key (5) to save ± YD and end selection is flashing.

SETUP DTM AND AUTOMATIC OFF TIMER

1. Press the DOWN ARROW key (3) to advance to SETUP.
2. Press the RIGHT ARROW key (5) to start selection flashing.
3. Press the UP ARROW key (2) or DOWN ARROW key (3) until WGD is flashing.



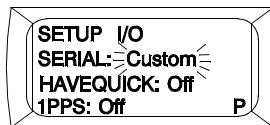
4. Press the RIGHT ARROW key (5) to save WGD WGS-84 and move to next selection.
5. Press the UP ARROW key (2) or DOWN ARROW key (3) until OFF is flashing for TIMER.



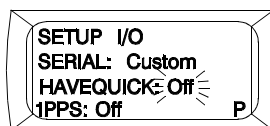
6. Press the RIGHT ARROW key (5) to save OFF and end selection flashing.

SETUP I/O SERIAL, HAVEQUICK AND 1PPS

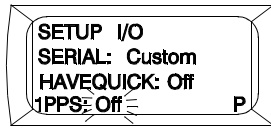
1. Press the DOWN ARROW key (3) to advance to SETUP I/O.
2. Press the RIGHT ARROW key (5) to start selection flashing.
3. Press the UP ARROW key (2) or DOWN ARROW key (3) until CUSTOM is flashing for SERIAL.



4. Press the RIGHT ARROW key (5) to save CUSTOM and move next selection.
5. Press the UP ARROW key (2) or DOWN ARROW key (3) until OFF is flashing for HAVEQUICK.



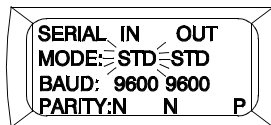
6. Press the RIGHT ARROW key (5) to save OFF and move to next selection.
7. Press the UP ARROW key (2) or DOWN ARROW key (3) until OFF is flashing for 1PPS.



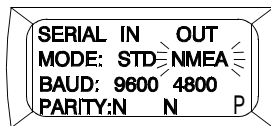
8. Press the RIGHT ARROW key (5) to save OFF and end selection flashing.

SERIAL IN OUT SETUP

1. Press the DOWN ARROW key (3) to advance to SERIAL IN OUT.
2. Press the RIGHT ARROW key (5) to start selection flashing.
3. Press the UP ARROW key (2) or DOWN ARROW key (3) until STD is flashing for SERIAL IN mode.



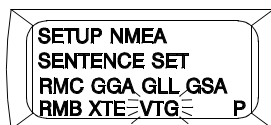
4. Press the RIGHT ARROW key (5) to save STD and move to next selection.
5. Press the UP ARROW key (2) or DOWN ARROW key (3) until NMEA is flashing for SERIAL OUT mode.



6. Press the RIGHT ARROW key (5) to save NMEA and end selection flashing.

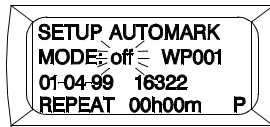
SETUP NMEA SENTENCE STRING

1. Press the DOWN ARROW key (3) to advance to SETUP.
2. Press the RIGHT ARROW key (5) to start selection flashing.
3. Enter the seven required NMEA sentence strings.
 - a. Press the UP ARROW key (2) or DOWN ARROW key (3) to change the sentence string.
 - b. After entering each 3 letter group sentence string, press the RIGHT ARROW key (5) to advance to the next string.
 - c. Continue until all letter groups are entered.
 - d. Ensure that sentence string is [RMC] [GGA] [GSA] [RMB] [XTE] [VTG].



SETUP AUTO MARK MODE

1. Press the DOWN ARROW key (3) to advance to SETUP AUTOMARK.
2. Press the RIGHT ARROW key (5) to start selection flashing.
3. Press the UP ARROW key (2) or DOWN ARROW key (3) until OFF is flashing for MODE.

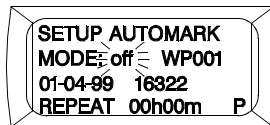


4. Press the RIGHT ARROW key (5) four times to save OFF and end selection flashing.

SET BULLSEYE**NOTE**

The bullseye menu will only activate when waypoint data is entered.

1. Press the DOWN ARROW key (3) to advance to SET BULLSEYE.
2. Press the RIGHT ARROW key (5) to start selection flashing.



3. Press the UP ARROW key (2) or DOWN ARROW key (3) to select flashing OFF.
4. Press the RIGHT ARROW key (5) to save OFF and end selection flashing.

SETUP OPERATOR ID

1. Press the DOWN ARROW key (3) to advance to SETUP OPERATOR ID.
2. Press the RIGHT ARROW key (5) to start selection flashing.
3. Press the UP ARROW key (2) or DOWN ARROW key (3) to enter the operator ID.
4. After each letter/number is entered, press the RIGHT ARROW key (5) to advance to the next letter/number position.
5. Press the UP ARROW key (2) or DOWN ARROW key (3) to change the letter/number.
6. Continue until the complete operator ID is entered.
7. Press the RIGHT ARROW key (5) until the double arrow symbol appears in the right lower corner of the display to the left of P.

SETUP APPROACH

1. Press the DOWN ARROW key (3) to advance to SETUP APPROACH.
2. Verify default settings.
3. Press the POS key (6) to end setup and return to POSITION SCREEN.

END OF WORK PACKAGE

**OPERATOR MAINTENANCE
CAUSEWAY FERRY
PRECISION LIGHTWEIGHT GLOBAL POSITIONING RECEIVER (PLGR)
OPERATION UNDER USUAL CONDITIONS**

INITIAL SETUP:**Tools**

Gloves, Men's and Women's (Leather Palm) (Item 31, WP 0105 00)
Goggles, Sun, Wind and Dust (Safety) (Item 34, WP 0105 00)
Life Preserver, Vest (Item 45, WP 0105 00)
Helmet, Safety (Brown) (Item 40, WP 0105 00)

Personnel Required

Seaman 88K

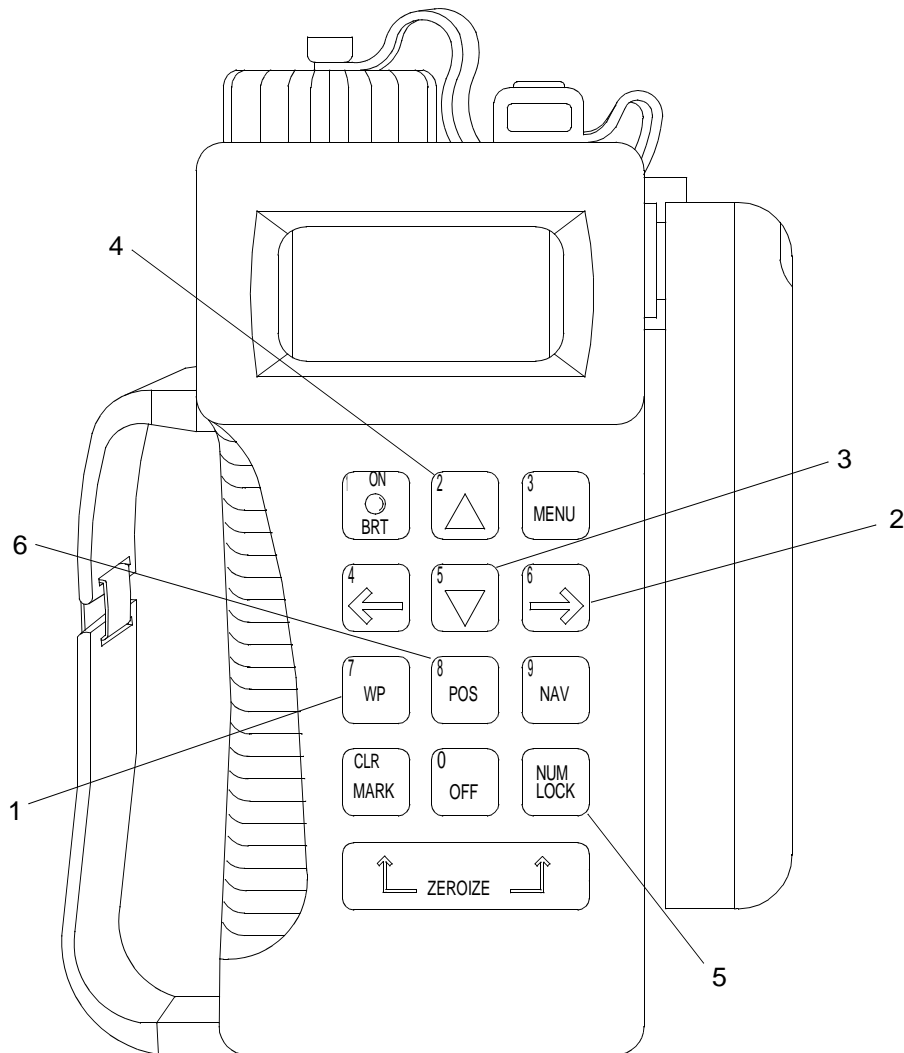
**OPERATING PROCEDURES - SETUP WAYPOINTS USING THE PRECISION LIGHTWEIGHT
GLOBAL POSITIONING RECEIVER (PLGR)****ENTERING WAYPOINTS**

WARNING

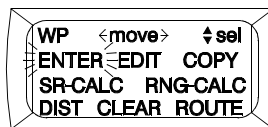
**VEST****HELMET PROTECTION****HEAVY PARTS****MOVING PARTS**

All personnel must wear personal flotation device, hard hat, safety shoes and gloves during CF operations and maintenance. Failure to observe these precautions could result in serious injury or death.

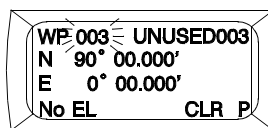
1. Press the WP key (1) to access the WAYPOINTS OPTIONS menu.



2. Press the RIGHT ARROW key (2) until ENTER is flashing.



3. Press the DOWN ARROW key (3).
4. Press the RIGHT ARROW key (2) to start the waypoint number field in the upper left corner flashing.

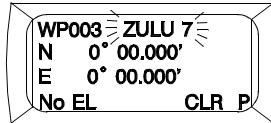


NOTE

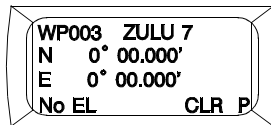
Waypoint numbers range from 000 to 999. Present position is always waypoint 000.
Waypoint 000 cannot be edited.

5. Change the waypoint number as desired using the UP ARROW key (4) or DOWN ARROW key (3).

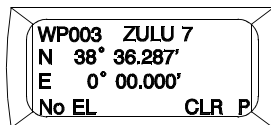
6. Press the RIGHT ARROW key (2) twice to start the waypoint label field flashing.



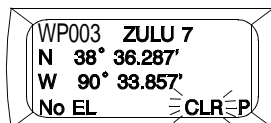
7. Press the DOWN ARROW key (3) to start the first letter/number position flashing.
8. Use the UP ARROW key (4) or DOWN ARROW key (3) to change the first letter/number in the waypoint label.
9. Press the RIGHT ARROW key (2) to advance to the next letter/number position.
10. Use the UP ARROW key (4) or DOWN ARROW key (3) to change the letter/number. Continue until the complete waypoint name is entered. Waypoint names may not exceed ten characters.
11. Press the RIGHT ARROW key (2) as necessary to move to the latitude field.



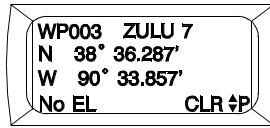
12. Toggle between N or S using the UP ARROW key (4).
13. Press the RIGHT ARROW key (2) to move to the first numeric latitude number.
14. Use the UP ARROW key (4) or DOWN ARROW key (3) to change the number.
15. Progress to each number using the RIGHT ARROW key (2) until the complete latitude of the waypoint is entered.
16. Press the RIGHT ARROW key (2) to move to the longitude field. Toggle between W or E using the UP ARROW key (4). Press the RIGHT ARROW key (2) to move to the first numeric longitude number. Use the UP ARROW key (4) or DOWN ARROW key (3) to change the number. Progress to each number using the RIGHT ARROW key (2) until the complete longitude of the waypoint is entered.



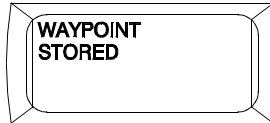
17. Toggle between W or E using the UP ARROW key (4).
18. Press the RIGHT ARROW key (2) to move to the first numeric longitude number.
19. Use the UP ARROW key (4) or DOWN ARROW key (3) to change the number. Progress to each number using the RIGHT ARROW key (2) until the complete longitude of the waypoint is entered.
20. Press the RIGHT ARROW key (2) twice. CLR will be flashing.



21. Press the NUM LOCK key (5) to change the PLGR to the CONTROL mode. AP will be displayed in the lower right hand corner of the display. Press the RIGHT ARROW key (2) to move the cursor next to the P. An UP and DOWN ARROW symbol will appear next to the letter P.



22. Press the DOWN ARROW key (3) and observe the display. WAYPOINT STORED will appear and the PLGR will automatically default to page 2 of waypoints.



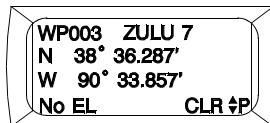
23. For vessels without a gyro compass, press the RIGHT ARROW key (2) until NO MAGVAR is flashing. Enter the magnetic variation from the chart used for the waypoint. Press the RIGHT ARROW key (2) three times.
24. Press the DOWN ARROW key (3) to enter another waypoint or exit by pressing the POS key (6).

EDITING A WAYPOINT

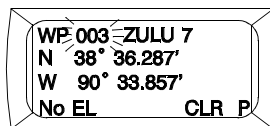
1. Press the WP key (1).
2. Press the RIGHT ARROW key (2) until EDIT is flashing.



3. Press the UP ARROW key (4). A waypoint will appear on the display.



4. Press the RIGHT ARROW key (2). The waypoints number field will be flashing. Use the UP ARROW key (4) or DOWN ARROW key (3) to change the waypoint number or press the NUM LOCK key (5) and enter the number of the waypoint.

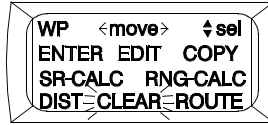


5. Change the waypoint data using the procedures for entering a waypoint.

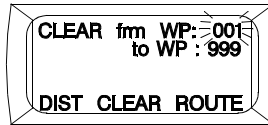
CLEARING A WAYPOINT**NOTE**

Clearing a waypoint will also clear any routes that contain this waypoint.

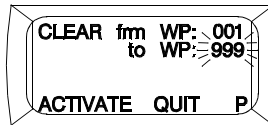
1. Press the WP key (1).
2. Press the RIGHT ARROW key (2) until CLEAR is flashing.



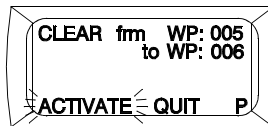
3. Press the UP ARROW key (4).
4. Press the RIGHT ARROW key (2) until FRM: WP number is flashing.



5. Press the UP ARROW key (4) to start the first number position of the waypoint number flashing.
6. Press the RIGHT ARROW key (2) to enter the next digit of the waypoint to be deleted. Continue until the complete waypoint number is entered.
7. Press the RIGHT ARROW key (2) until TO: WP number is flashing.

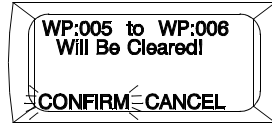


8. Press the UP ARROW key (4) to start the first number position of the waypoint number flashing.
9. Press the RIGHT ARROW key (2) to enter the next digit of the waypoint to be deleted. Continue until the complete waypoint number is entered.
10. Press the RIGHT ARROW key (3) until ACTIVATE is flashing.

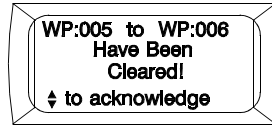


11. Press the UP ARROW key (1).

12. Press the RIGHT ARROW key (3) until CONFIRM is flashing.



13. Press the UP ARROW key (4). The display will advise the operator of the waypoints that will be deleted.



14. Press the POS key (6) to return to the POS display.

END OF WORK PACKAGE

**OPERATOR MAINTENANCE
CAUSEWAY FERRY
PRECISION LIGHTWEIGHT GLOBAL POSITIONING RECEIVER (PLGR)
OPERATION UNDER USUAL CONDITIONS**

INITIAL SETUP:**Tools**

Gloves, Men's and Women's (Leather Palm) (Item 31, WP 0105 00)
Goggles, Sun, Wind and Dust (Safety) (Item 34, WP 0105 00)
Life Preserver, Vest (Item 45, WP 0105 00)
Helmet, Safety (Brown) (Item 40, WP 0105 00)

Personnel Required

Seaman 88K

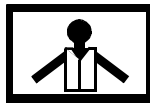
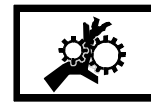
References

TM 11-5825-291-13

OPERATING PROCEDURES - SETUP ROUTE NAVIGATION USING THE PRECISION LIGHTWEIGHT GLOBAL POSITIONING RECEIVER (PLGR)

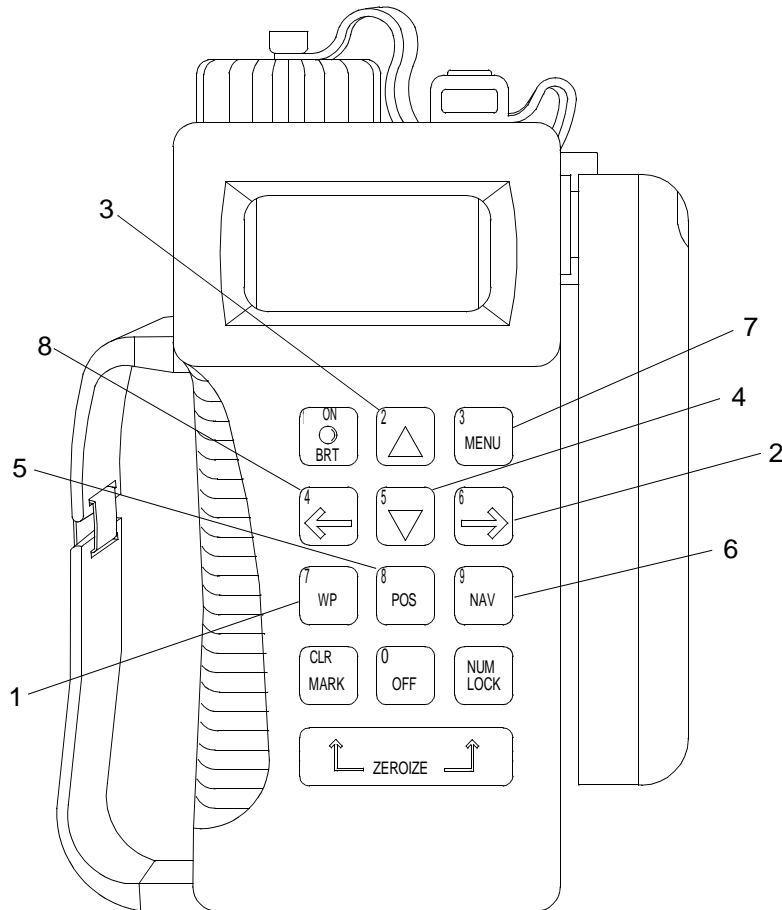
PLANNING A ROUTE

WARNING

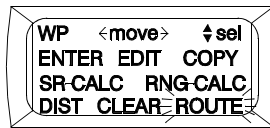
**VEST****HELMET PROTECTION****HEAVY PARTS****MOVING PARTS**

All personnel must wear personal flotation device, hard hat, safety shoes and gloves during CF operations and maintenance. Failure to observe these precautions could result in serious injury or death.

1. Press the WP key (1).



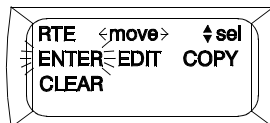
2. Press the RIGHT ARROW key (2) until ROUTE is flashing.



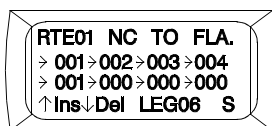
3. Press the UP ARROW key (3) to select ROUTE.
4. ENTER will be flashing. Press the UP ARROW key (3) to select ENTER.



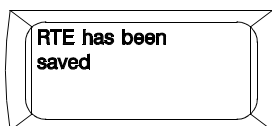
5. Using the UP ARROW key (3) or DOWN ARROW key (4), assign a route number to the new route.
6. Press the RIGHT ARROW key (2) to highlight the route name field. Press the UP ARROW key (3) to select the first letter of the route name. Use the UP ARROW key (3) or DOWN ARROW key (4) to change to the desired letter. Press the RIGHT ARROW key (2) to advance to the next letter position. Repeat until the route name is entered.



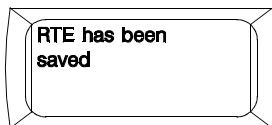
7. Press the RIGHT ARROW key (2) until the arrow left of the first group of three digits is flashing.
8. Press the UP ARROW key (3) or DOWN ARROW key (4) to change to the desired letter.
9. Press the RIGHT ARROW key (2) to advance to the next letter position. Repeat until the route name is entered.
10. Press the RIGHT ARROW key (2) until the arrow left of the first group of three digits is flashing.
11. Press the RIGHT ARROW key (2) to start the first group of three digits flashing.
12. Press the UP ARROW key (3) to select the first waypoint number.
13. Press the RIGHT ARROW key (2). Press the UP ARROW key (3) to enter the next waypoint. Continue to add waypoints until all waypoints have been entered.



14. After all waypoints have been entered, exit the display by pressing the WP key (1), POS key (5), NAV key (6) or MENU key (7). The display informs the user that the route has not been saved. SAVE will be flashing.

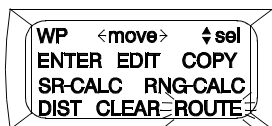


15. Press the UP ARROW key (3) to save the route.

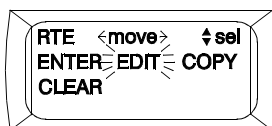


EDITING A ROUTE

1. Press the WP key (1). Press the RIGHT ARROW key (2) until ROUTE is flashing.



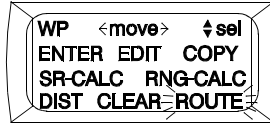
2. Press the UP ARROW key (3) to select ROUTE. Press the RIGHT ARROW key (2) until EDIT is flashing.



3. Press the UP ARROW key (3) to select EDIT.
4. Using the UP ARROW key (3) or DOWN ARROW key (4), select the route number to be edited. Follow the procedures for planning a route to edit the route as required.

COPYING A ROUTE

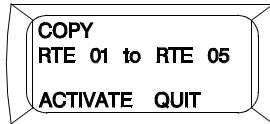
1. Press the WP key (1).
2. Press the RIGHT ARROW key (2) until ROUTE is flashing.



3. Press the UP ARROW key (3).
4. Press the RIGHT ARROW key (2) until COPY is flashing.



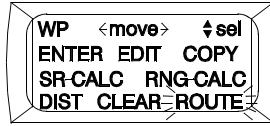
5. Press the UP ARROW key (3).
6. Enter the route numbers for copying to/from using the RIGHT ARROW key (2) or LEFT ARROW key (8) to select to/from and the UP ARROW key (3) or DOWN ARROW key (4) to change the route numbers.
7. Press the RIGHT ARROW key (2) until ACTIVATE is flashing.



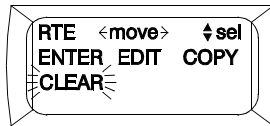
8. Press the UP ARROW key (3).
9. Press the POS key (5) to exit the WP menu.

CLEARING A ROUTE

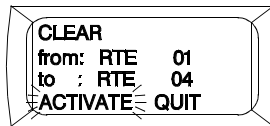
1. Press the WP key (1).
2. Press the RIGHT ARROW key (2) until ROUTE is flashing.



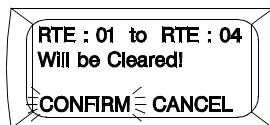
3. Press the UP ARROW key (3).
4. Press the RIGHT ARROW key (2) until CLEAR is flashing.



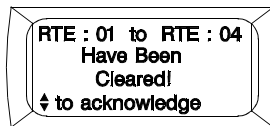
5. Press the UP ARROW key (3).
6. Press the RIGHT ARROW key (2) until the FROM: RTE number is flashing. Enter the starting route number to be deleted using the UP ARROW key (3).
7. Press the RIGHT ARROW key (2) until the TO: RTE number is flashing. Enter the ending route number to be deleted using the UP ARROW key (3).
8. Press the RIGHT ARROW key (2) until ACTIVATE flashes.



9. Press the UP ARROW key (3).
10. Press the RIGHT ARROW key (2) until CONFIRM flashes.



11. Press the UP ARROW key (3).



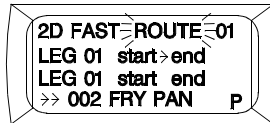
12. Press the POS key (5) to return to POS display.

NAVIGATING A COURSE

1. Press the NAV key (6). Press the RIGHT ARROW key (2) to start the type of navigation flashing.
2. Press the UP ARROW key (3) to start 2D FAST flashing.



3. Press the RIGHT ARROW key (2) to advance to the next field. Press the DOWN ARROW key (4) until ROUTE is flashing.



4. Press the RIGHT ARROW key (2) to advance to the route number field. Use the UP ARROW key (3) or DOWN ARROW key (4) to change the route number to the desired route.
5. Press the RIGHT ARROW key (2) to advance to the leg number field. Use the UP ARROW key (3) or DOWN ARROW key (4) to change the leg number.
6. Press the RIGHT ARROW key (2) to advance to the START - END/END - START field. Use the UP ARROW key (3) or DOWN ARROW key (4) to change START - END or END - START.
7. Press the RIGHT ARROW key (2) to complete programming the route.

NOTE

Pages 2 and 4 display information on destination, slant range, track, ground speed, azimuth and north reference, elevation angle and cross track error. Page 3 displays information on range, time to go, elevation difference and minimum miss distance.

8. Refer to page 2, 3 or 4 if more navigational information is necessary.
9. Press the POS key (5) to exit the NAV display.

END OF WORK PACKAGE

**OPERATOR MAINTENANCE
CAUSEWAY FERRY
PRECISION LIGHTWEIGHT GLOBAL POSITIONING RECEIVER (PLGR)
OPERATION UNDER USUAL CONDITIONS**

INITIAL SETUP:**Tools**

Gloves, Men's and Women's (Leather Palm) (Item 31, WP 0105 00)
Goggles, Sun, Wind and Dust (Safety) (Item 34, WP 0105 00)
Life Preserver, Vest (Item 45, WP 0105 00)
Helmet, Safety (Brown) (Item 40, WP 0105 00)

Personnel Required

Seaman 88K

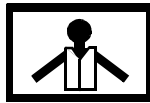
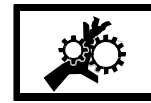
References

TM 11-5825-291-13

**OPERATING PROCEDURES - PERFORM CRYPTO VARIABLE OPERATIONS - PRECISION
LIGHTWEIGHT GLOBAL POSITIONING RECEIVER (PLGR)**

CRYPTO KEY ENTRY USING THE KYK-13

WARNING

**VEST****HELMET PROTECTION****HEAVY PARTS****MOVING PARTS**

All personnel must wear personal flotation device, hard hat, safety shoes and gloves during CF operations and maintenance. Failure to observe these precautions could result in serious injury or death.

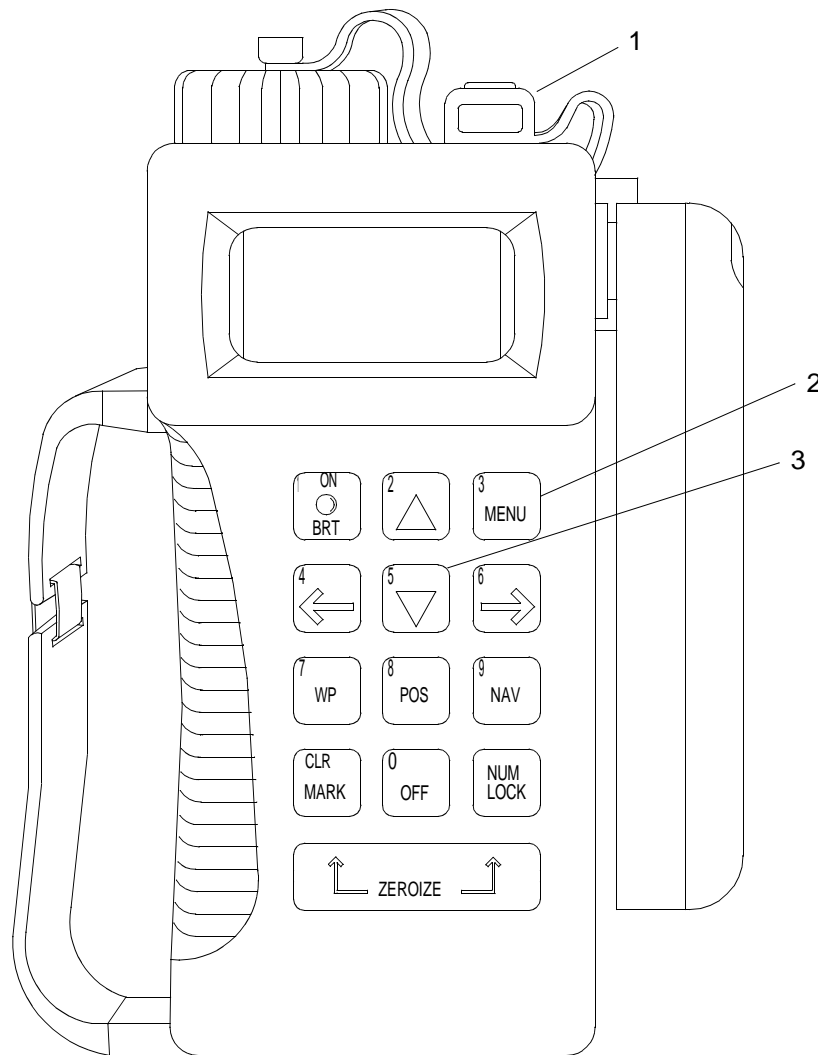
All shipboard PLGRs must be keyed using the correct crypto key prior to combat operations. Failure to observe these precautions could result in loss of life.

NOTE

The PLGR has a national security agency (NSA) module that stores the crypto keys. Since the crypto keys are stored in this tamper proof module (called a Precise Positioning Service Security Module, or PPS-SM), the PLGR is not classified when crypto keys are installed.

The PPS-SM does not protect classified waypoints. When classified waypoints are stored in the PLGR, the PLGR is classified at the same level as the waypoints.

1. Connect the KYK-13 to the J1 port (1) on the PLGR. Ensure that the PLGR is turned on and not performing a self-test.



2. Set the KYK-13 selector switch to the position that contains the crypto key.
3. Set the KYK-13 mode switch to ON. The light on the KYK-13 flashes showing a successful crypto load.

CRYPTO KEY ENTRY USING KOI-18

1. Connect the KOI-18 to the J1 port (1) on the PLGR. Ensure that the PLGR is turned on and not performing a self-test.
2. Press the MENU key (2) until the menu display with KOI-18 appears. Select and activate the KOI-18.
3. Select and activate LOAD. Immediately pull the paper tape through the KOI-18.
4. After loading, select and activate QUIT.
5. Bring up the CRYPTO pages from the system menu. Verify the crypto key status.

-
6. Verify the crypto key status.
 - a. Select menu second page.
 - b. Ensure that crypto is displayed on line 4 or crypto keys are not installed or are not valid.
 7. Remove the KOI-18 from the PLGR.

CRYPTO KEY ENTRY USING AN/CYZ-10 (SPECIAL ANCD)

1. Turn on the ANCD, read RADIO/SOI/SUPERVISOR.
2. Enter RADIO, read SEND/RECEIVE/DATABASE/SETUP/COMSEC/TIME.
3. Enter COMSEC, read VG/LD/RV/AK/MK/VU.
4. Enter LD, read SELECT TEK/KEK.
5. Enter TEK.
6. Select the desired GPS key, then press ENTER.
7. Enter QUIT, read CONNECT ANCD TO RT - DO NOT COMPLY.
8. Press the DOWN ARROW key (3), read PRESS LOAD ON RT- DO NOT COMPLY.
9. Turn the PLGR on, wait for self-test to complete.
10. Connect ANCD to the J1 port (1) on the PLGR. GPS key transfers automatically.
11. The ANCD reports: 1 KEYS TRANSFERRED. The PLGR reports KEY LOADED.
12. Disconnect ANCD from the J1 port (1) on the PLGR.

END OF WORK PACKAGE

**OPERATOR MAINTENANCE
CAUSEWAY FERRY
DC TO DC CONVERTER
OPERATION UNDER USUAL CONDITIONS**

INITIAL SETUP:

Tools

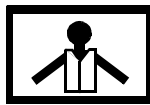
- Gloves, Men's and Women's (Leather Palm) (Item 31, WP 0105 00)
- Goggles, Sun, Wind and Dust (Safety) (Item 34, WP 0105 00)
- Life Preserver, Vest (Item 45, WP 0105 00)
- Helmet, Safety (Brown) (Item 40, WP 0105 00)

Personnel Required

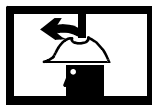
Seaman 88K

OPERATING PROCEDURES - OPERATE THE DC TO DC CONVERTER

WARNING



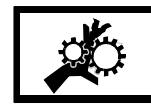
VEST



HELMET PROTECTION



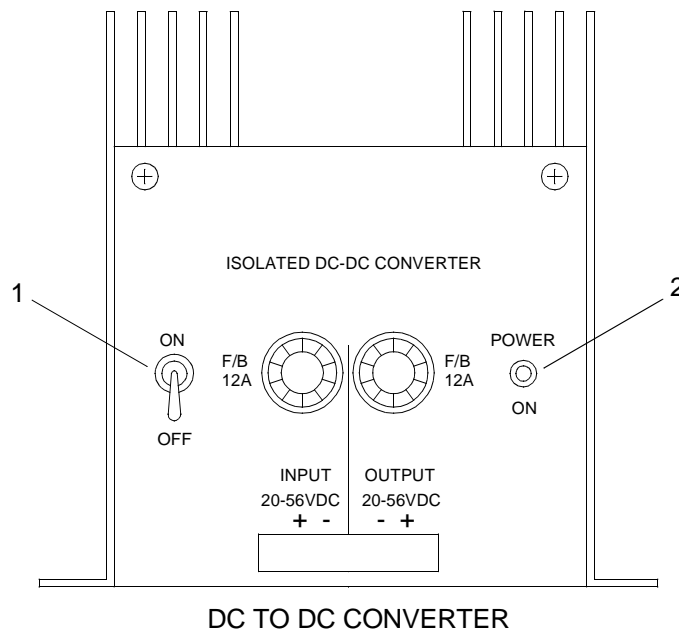
HEAVY PARTS



MOVING PARTS

All personnel must wear personal flotation device, hard hat, safety shoes and gloves during CF operations and maintenance. Failure to observe these precautions could result in serious injury or death.

1. Move power switch (1) to ON position.



2. Ensure that power indicator light (2) is lit, indicating that the converter is producing power.

END OF WORK PACKAGE

**OPERATOR MAINTENANCE
CAUSEWAY FERRY
ANCHOR
OPERATION UNDER USUAL CONDITIONS**

INITIAL SETUP:**Tools**

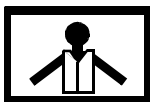
Tool Kit, General Mechanic's (Rail and Marine) (Item 76, WP 0105 00)
Gloves, Men's and Women's (Leather Palm) (Item 31, WP 0105 00)
Goggles, Sun, Wind and Dust (Safety) (Item 34, WP 0105 00)
Life Preserver, Vest (Item 45, WP 0105 00)
Helmet, Safety (Brown) (Item 40, WP 0105 00)

Personnel Required

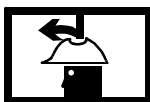
Seaman 88K

OPERATING PROCEDURES - ANCHOR DEPLOYMENT AND RECOVERY**DEPLOYMENT**

WARNING



VEST



HELMET PROTECTION



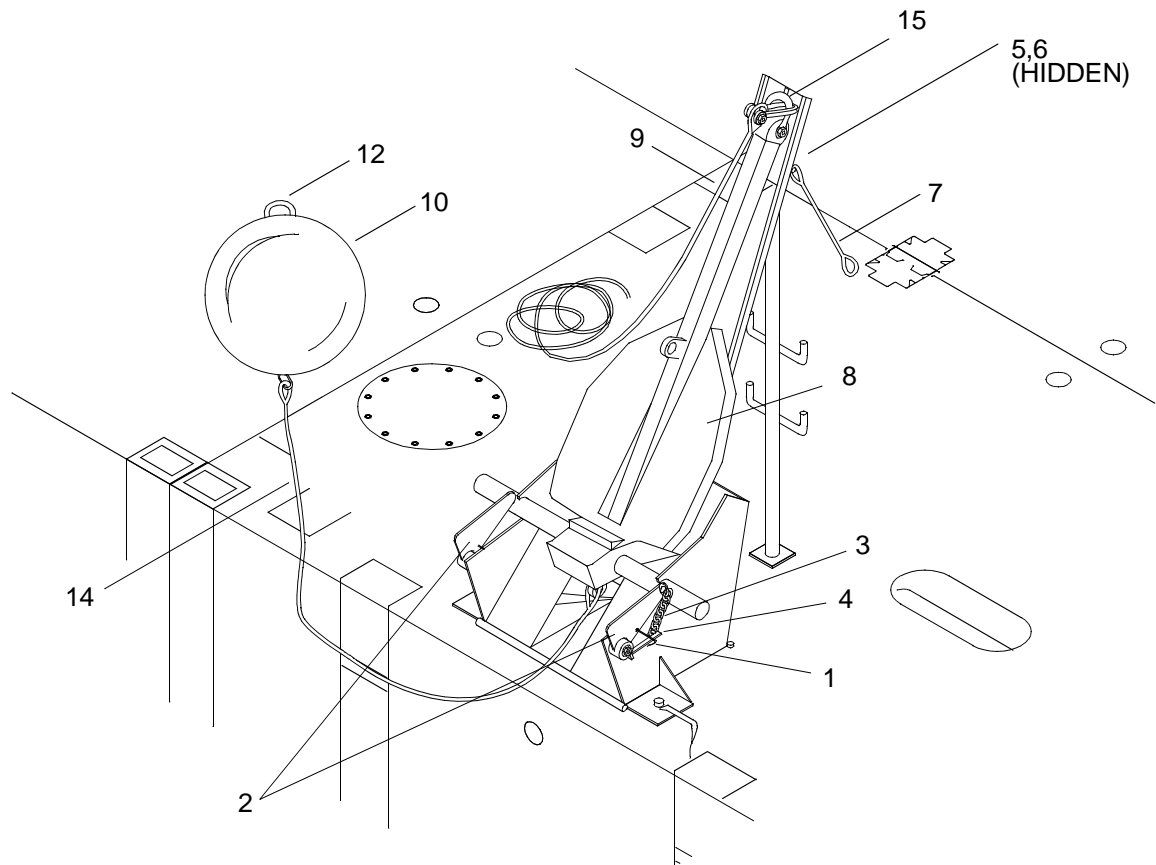
HEAVY PARTS



MOVING PARTS

All personnel must wear personal flotation device, hard hat, safety shoes and gloves during CF operations and maintenance. Failure to observe these precautions could result in serious injury or death.

1. Remove ramp extension locking pins (1) from the ramp extensions (2).



2. Remove the ramp extension locking chains (3) from their associated holding brackets (4).
3. Cut the nylon tiedown straps (5) securing the leg and release arm of the release hook (6).

CAUTION

Stand clear of the anchor buoy, buoy rope and anchor rope during anchor deployment.

4. Pull the rope (7) attached to the release hook (6) to deploy anchor (8).
5. When anchor (8) has reached desired depth, secure the anchor rope (9) to the deck.

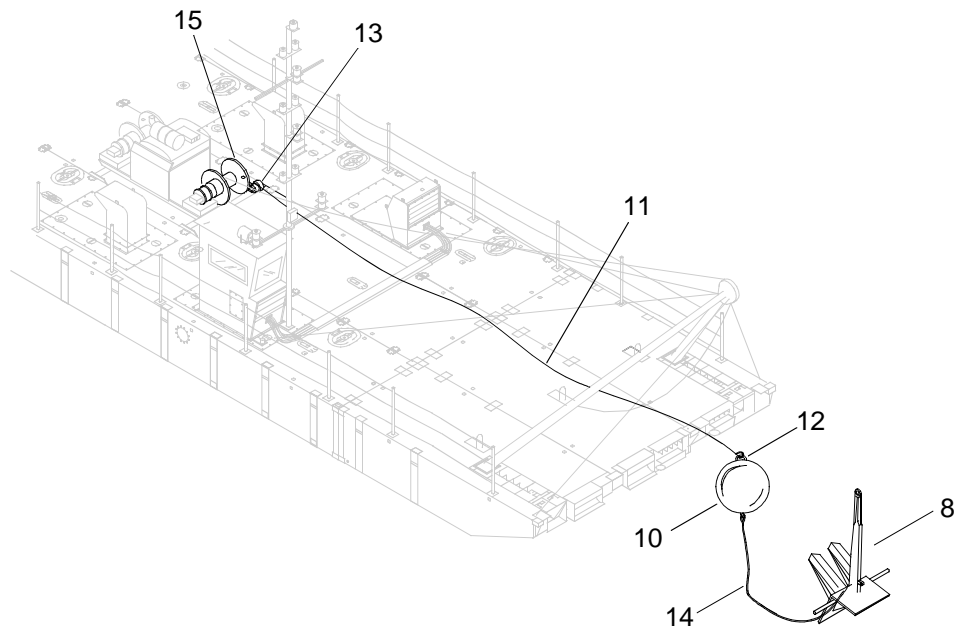
RECOVERY

NOTE

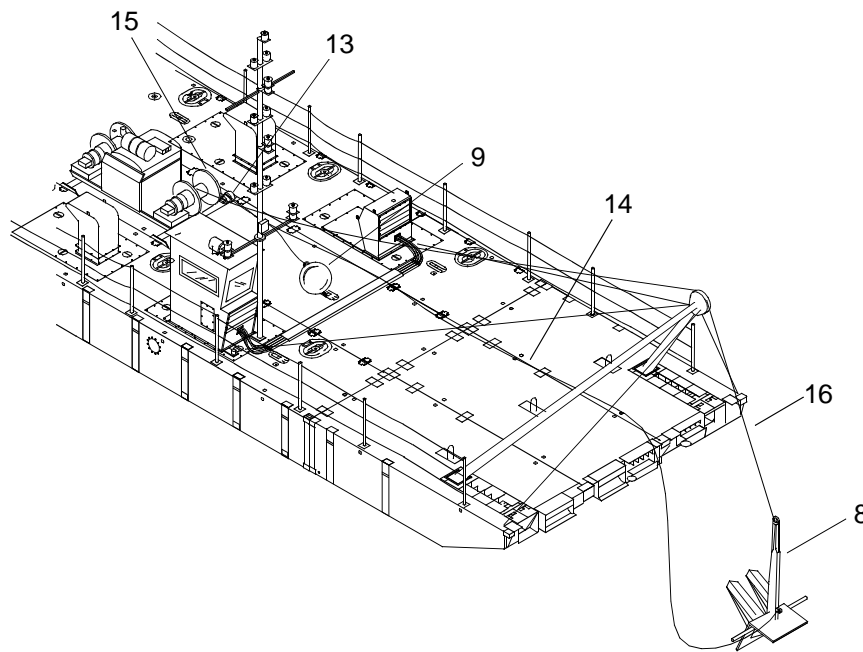
Anchor location is determined by locating the anchor buoy.

A warping tug (WT) is used in recovery of the anchor after release from the Causeway Ferry (CF).

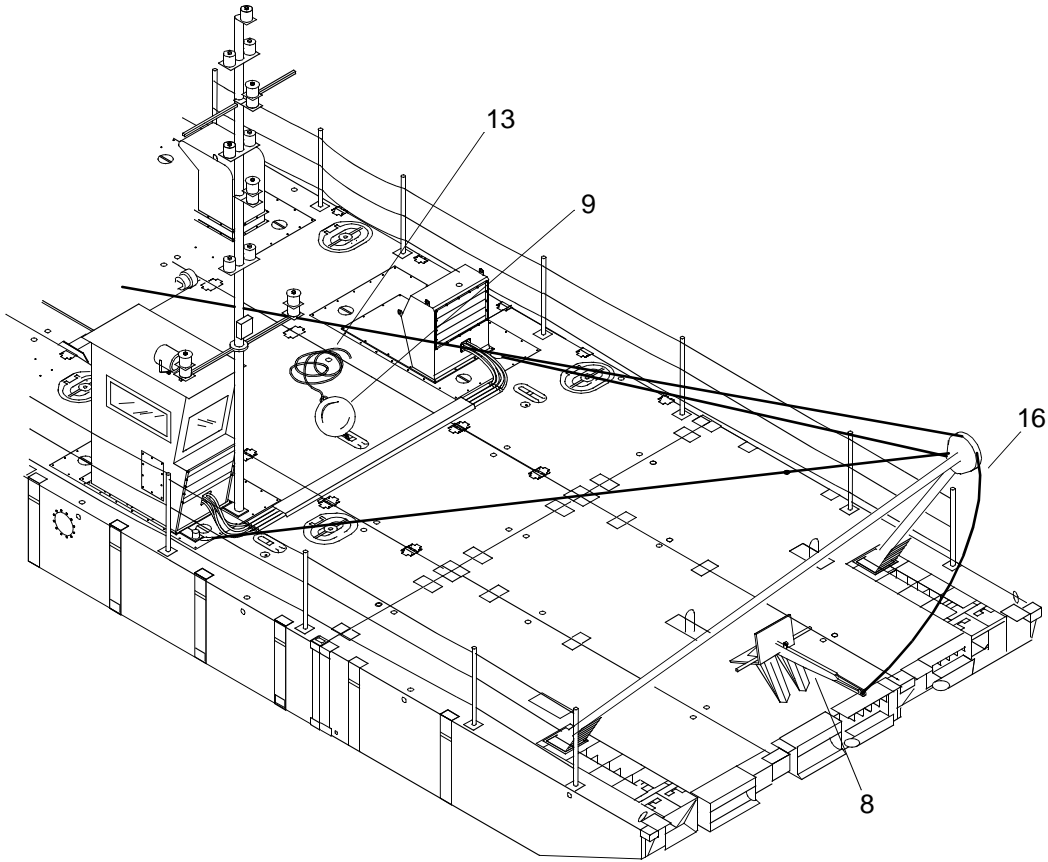
1. Capture the buoy (10) and secure a tagline (11) to the clevis (12) on the top of the buoy (10).



2. Wrap the tagline (11) around the gypsy winch drum (13), take a bite on the rope and raise the buoy (10) out of the water until enough buoy rope (14) is on the deck so that it can be wrapped around the gypsy winch drum (13).
3. Remove the tagline (11) from the buoy clevis (12) and from gypsy drum (13).
4. Remove the buoy (10) from the buoy rope (14) and stow the tagline (11), buoy (10) and buoy rope (14) out of the way.
5. Wrap the buoy rope (14) around of the gypsy winch drum (13), take a bite on the rope and raise the anchor (8) until the anchor's top shackle (15) is accessible.



6. Secure the A-frame boom winch cable (16) to the anchor's top shackle (15).
7. Using both the gypsy winch and A-frame boom winch together, raise and draw back on the anchor (8) until it can be placed on the deck.



END OF WORK PACKAGE

**OPERATOR MAINTENANCE
CAUSEWAY FERRY
BATTERY SELECTOR SWITCH
OPERATION UNDER USUAL CONDITIONS**

INITIAL SETUP:**Tools**

Gloves, Men's and Women's (Leather Palm) (Item 31, WP 0105 00)
 Goggles, Sun, Wind and Dust (Safety) (Item 34, WP 0105 00)
 Life Preserver, Vest (Item 45, WP 0105 00)
 Helmet, Safety (Brown) (Item 40, WP 0105 00)

Personnel Required

Seaman 88K

Equipment Condition

Propulsion Module Vented. (WP 0020 00)

OPERATING PROCEDURES - OPERATE BATTERY SELECTOR SWITCH

WARNING



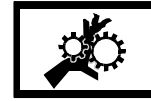
VEST



HELMET PROTECTION



HEAVY PARTS



MOVING PARTS

All personnel must wear personal flotation device, hard hat, safety shoes and gloves during CF operations and maintenance. Failure to observe these precautions could result in serious injury or death.

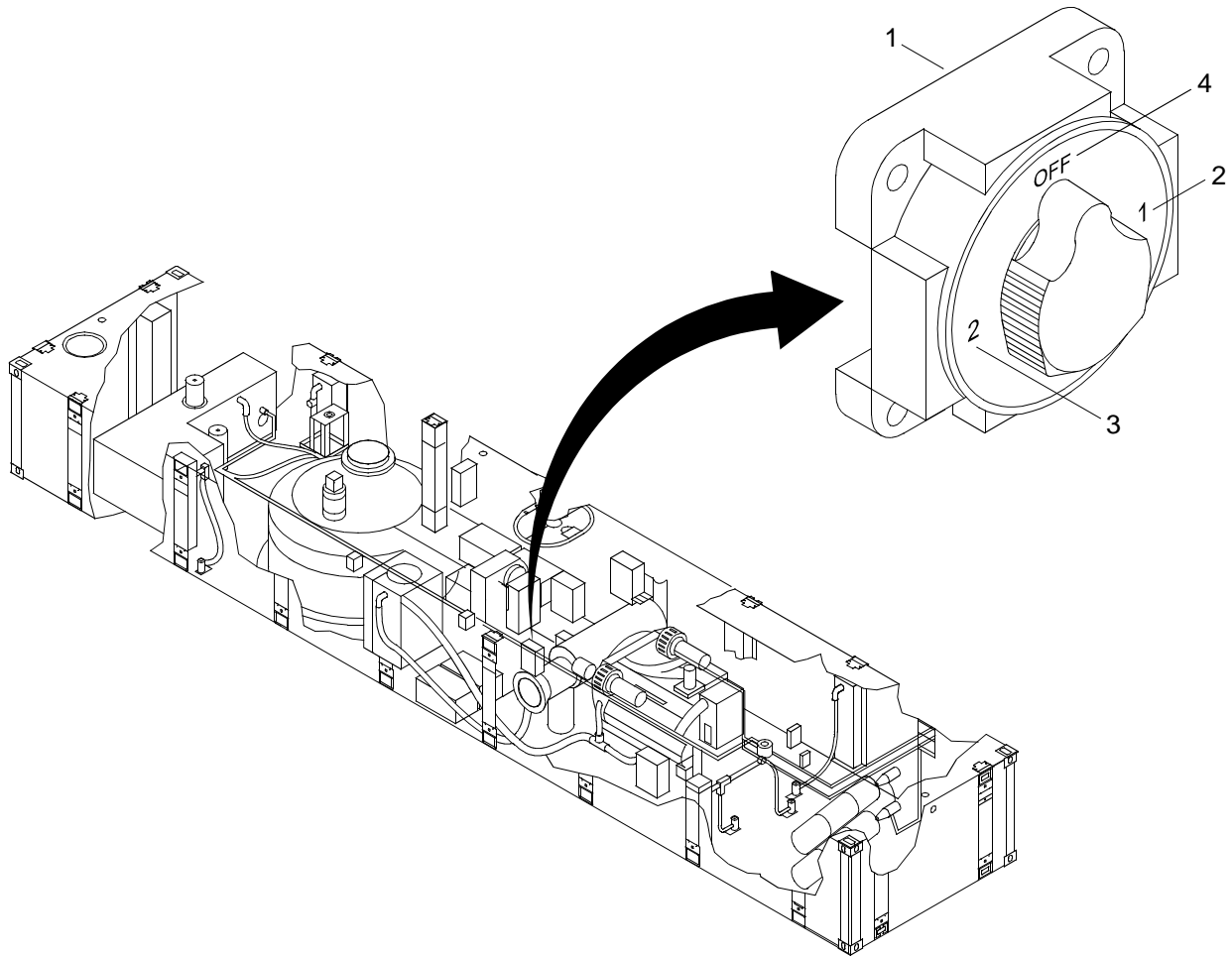
CAUTION

Engines must be shut down prior to turning the battery selector switch to the OFF position. Failure to comply will result in damage to equipment

NOTE

To prevent power from being supplied to the engines and below deck lighting simultaneously, the battery selector switch ALL position is not used.

1. Rotate battery selector switch (1) to position 1 (2) to deliver power to engine.



3. Rotate battery selector switch (1) to position 2 (3) to deliver power to below deck lighting.

CAUTION

Engines must be shut down prior to turning the battery selector switch to the OFF position. Failure to comply will result in damage to equipment

4. Turn off all power to the module by rotating the battery selector switch (1) to the OFF position (4).

END OF WORK PACKAGE

**OPERATOR MAINTENANCE
CAUSEWAY FERRY
OPERATORS CAB CHART (MAP) LIGHT
OPERATION UNDER USUAL CONDITIONS**

INITIAL SETUP:**Tools**

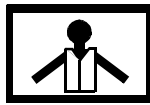
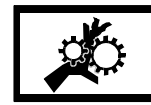
Gloves, Men's and Women's (Leather Palm) (Item 31, WP 0105 00)
 Goggles, Sun, Wind and Dust (Safety) (Item 34, WP 0105 00)
 Life Preserver, Vest (Item 45, WP 0105 00)
 Helmet, Safety (Brown) (Item 40, WP 0105 00)

Personnel Required

Seaman 88K

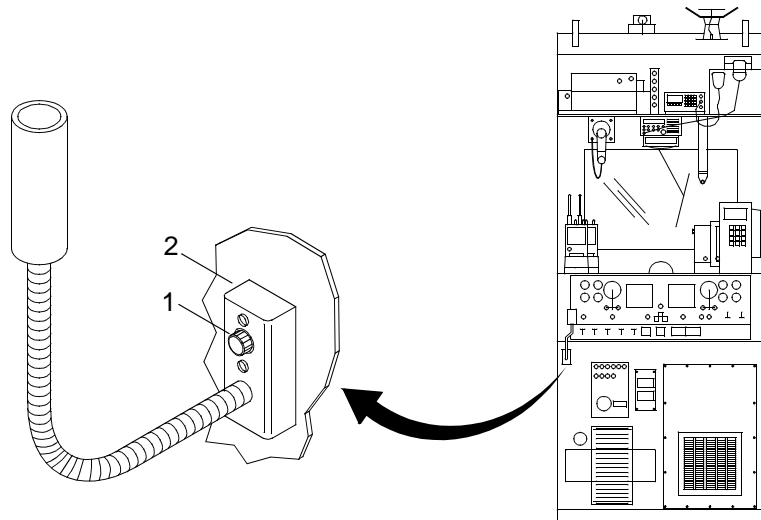
OPERATING PROCEDURES- OPERATORS CAB CHART (MAP) LIGHT

WARNING

**VEST****HELMET PROTECTION****HEAVY PARTS****MOVING PARTS**

All personnel must wear personal flotation device, hard hat, safety shoes and gloves during CF operations and maintenance. Failure to observe these precautions could result in serious injury or death.

1. Rotate the knob (1) on the map light (2) clockwise to turn ON.



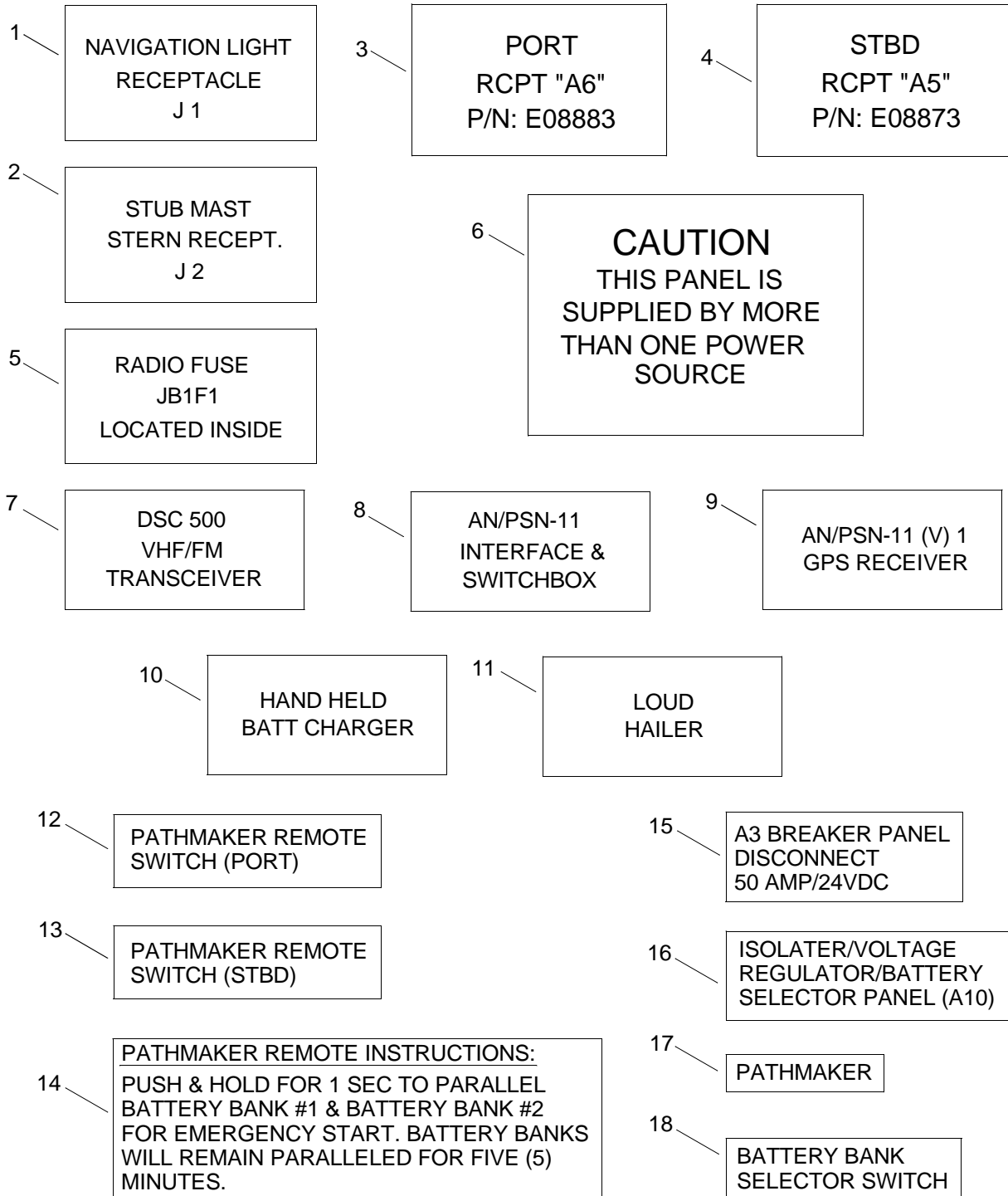
2. Rotate the knob (1) on the map light (2) clockwise to turn OFF.

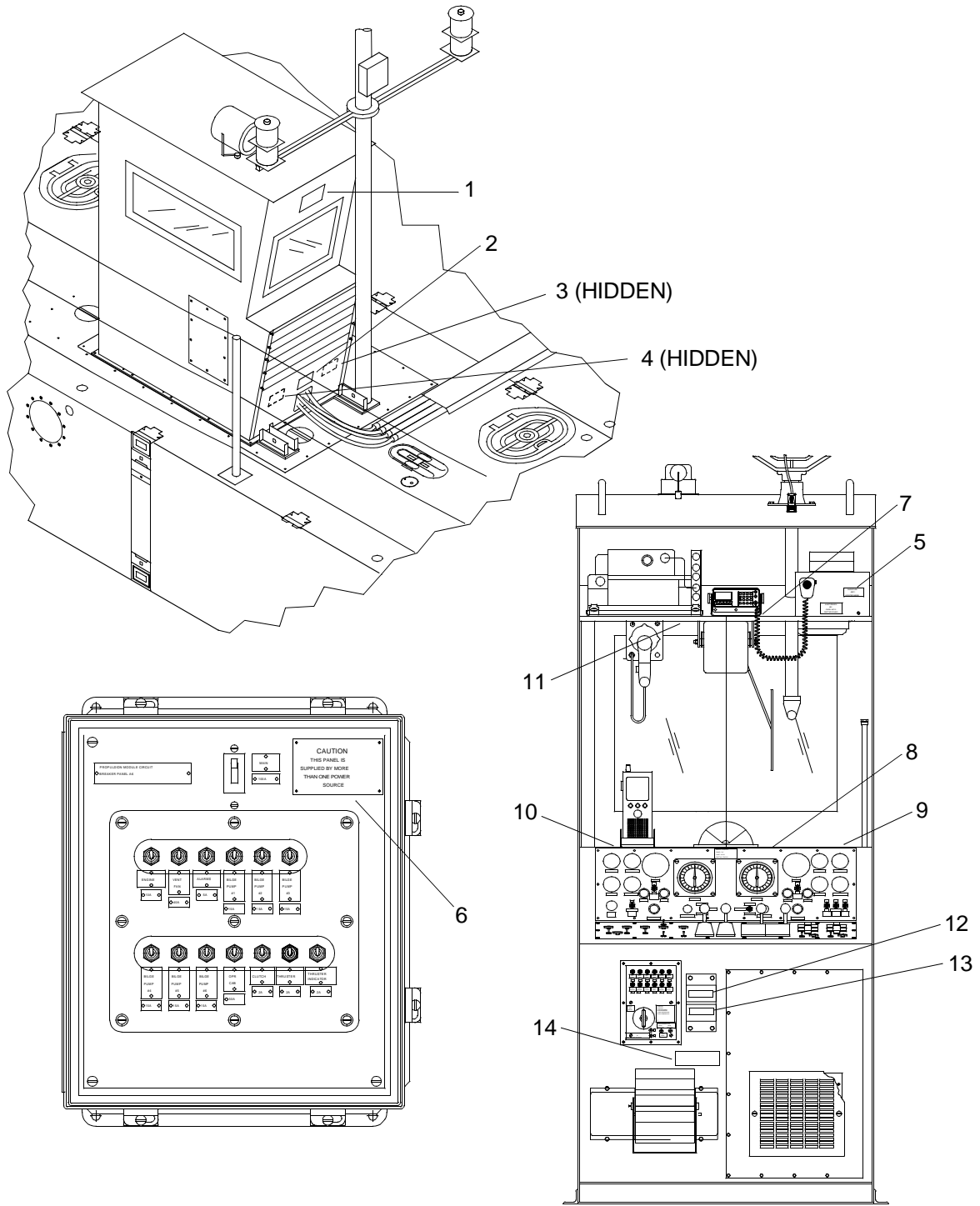
END OF WORK PACKAGE

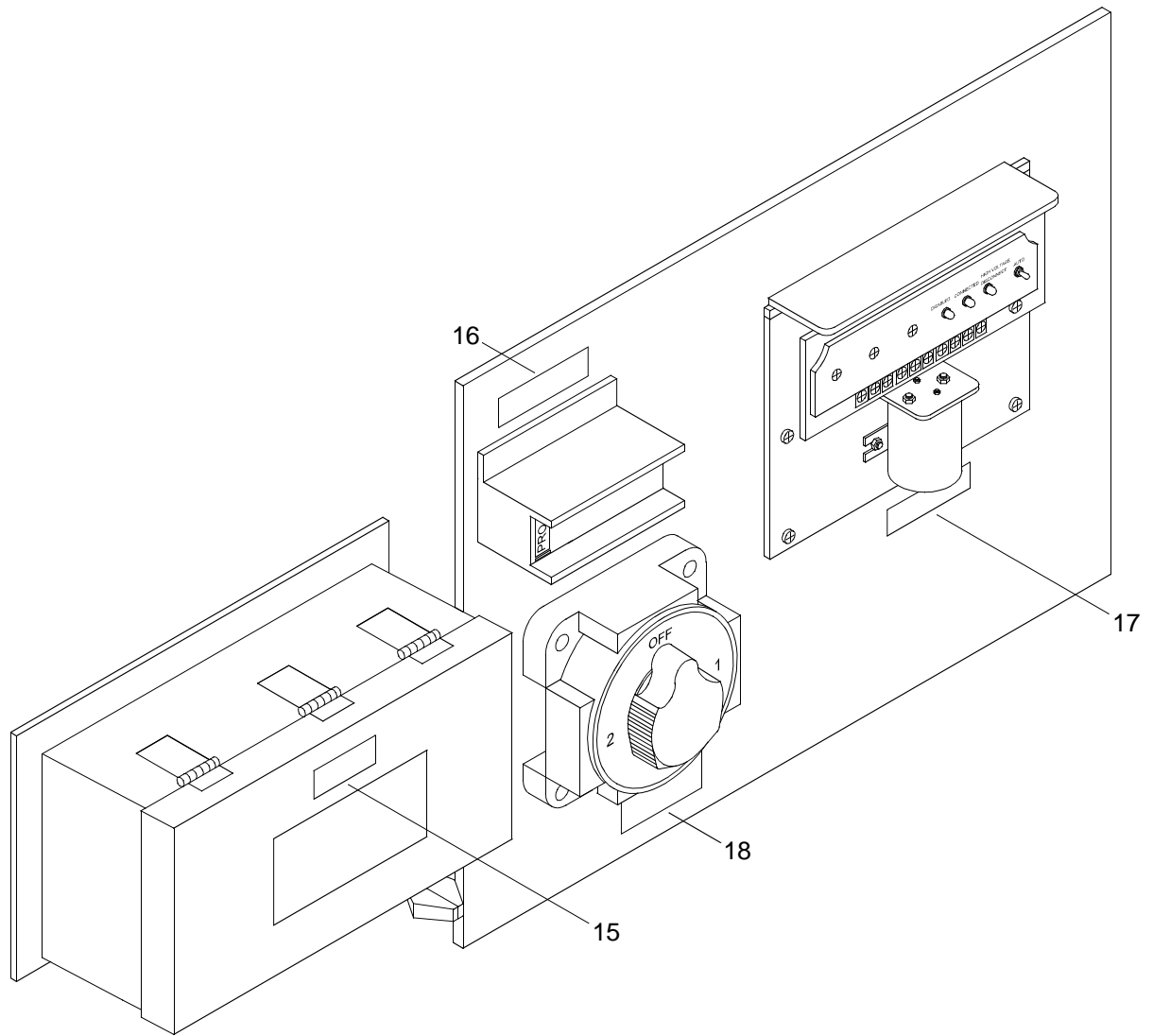
**OPERATOR MAINTENANCE
CAUSEWAY FERRY
DECALS AND INSTRUCTION PLATES
OPERATION UNDER USUAL CONDITIONS**

DECALS AND INSTRUCTION PLATE LOCATIONS FOR CAUSEWAY FERRY

This work package is provided to inform operator of the location and description of decals and instruction plates.







**OPERATOR MAINTENANCE
CAUSEWAY FERRY
DECK BOX
OPERATION UNDER USUAL CONDITIONS**

INITIAL SETUP:**Tools**

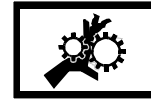
Tool Kit, General Mechanic's (Rail and Marine) (Item 76, WP 0105 00)
 Gloves, Men's and Women's (Leather Palm) (Item 31, WP 0105 00)
 Goggles, Sun, Wind and Dust (Safety) (Item 34, WP 0105 00)
 Life Preserver, Vest (Item 45, WP 0105 00)
 Helmet, Safety (Brown) (Item 40, WP 0105 00)
 Sling, Lifting, 5,300 lb (Green) (Item 70, WP 0105 00)
 Qty 2
 4 ¾ Ton ¾ in. Shackle (Item 5, WP 0105 00)

Personnel Required

Seaman 88K

PREPARATION FOR MOVEMENT - REMOVAL OF DECK BOX

WARNING

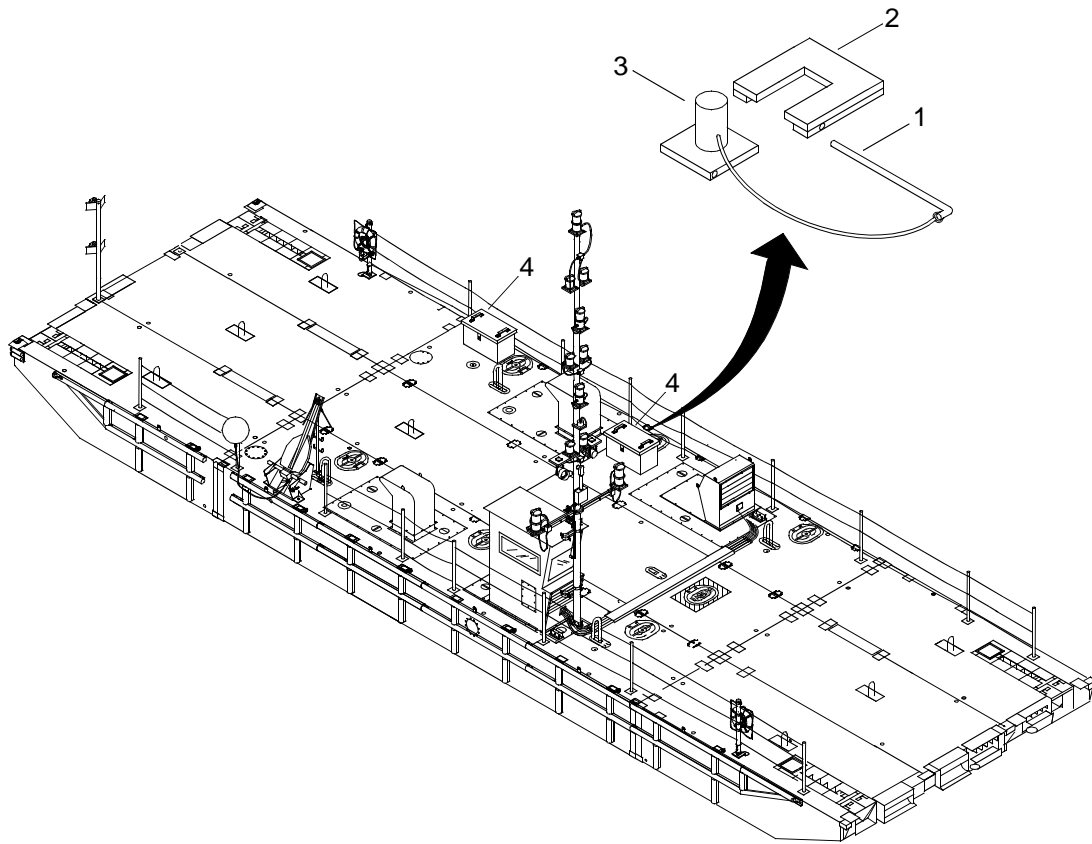
**VEST****HELMET PROTECTION****HEAVY PARTS****MOVING PARTS**

All personnel must wear personal flotation device, hard hat, safety shoes and gloves during CF operations and maintenance. Failure to observe these precautions could result in serious injury or death.

NOTE

This task is typical for removal of both fore and aft deck boxes.

1. Remove pins (1) from stanchion clips (2).



WARNING

**HEAVY PARTS**

2. Using crane, slings and shackles, Slide deck box feet (3) out of stanchion clips (2).

WARNING

**HEAVY PARTS**

3. Using crane, slings and shackles, position deck box (4) to prepare it for movement or stowage.
4. Remove slings and shackles from deck box (4).

END OF WORK PACKAGE

**OPERATOR MAINTENANCE
CAUSEWAY FERRY
CREW SHELTER
OPERATION UNDER USUAL CONDITIONS**

INITIAL SETUP:**Tools**

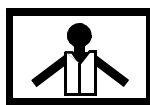
Tool Kit, General Mechanic's (Rail and Marine) (Item 76, WP 0105 00)
Gloves, Men's and Women's (Leather Palm) (Item 31, WP 0105 00)
Goggles, Sun, Wind and Dust (Safety) (Item 34, WP 0105 00)
Life Preserver, Vest (Item 45, WP 0105 00)
Helmet, Safety (Brown) (Item 40, WP 0105 00)

Personnel Required

Seaman 88K (2)

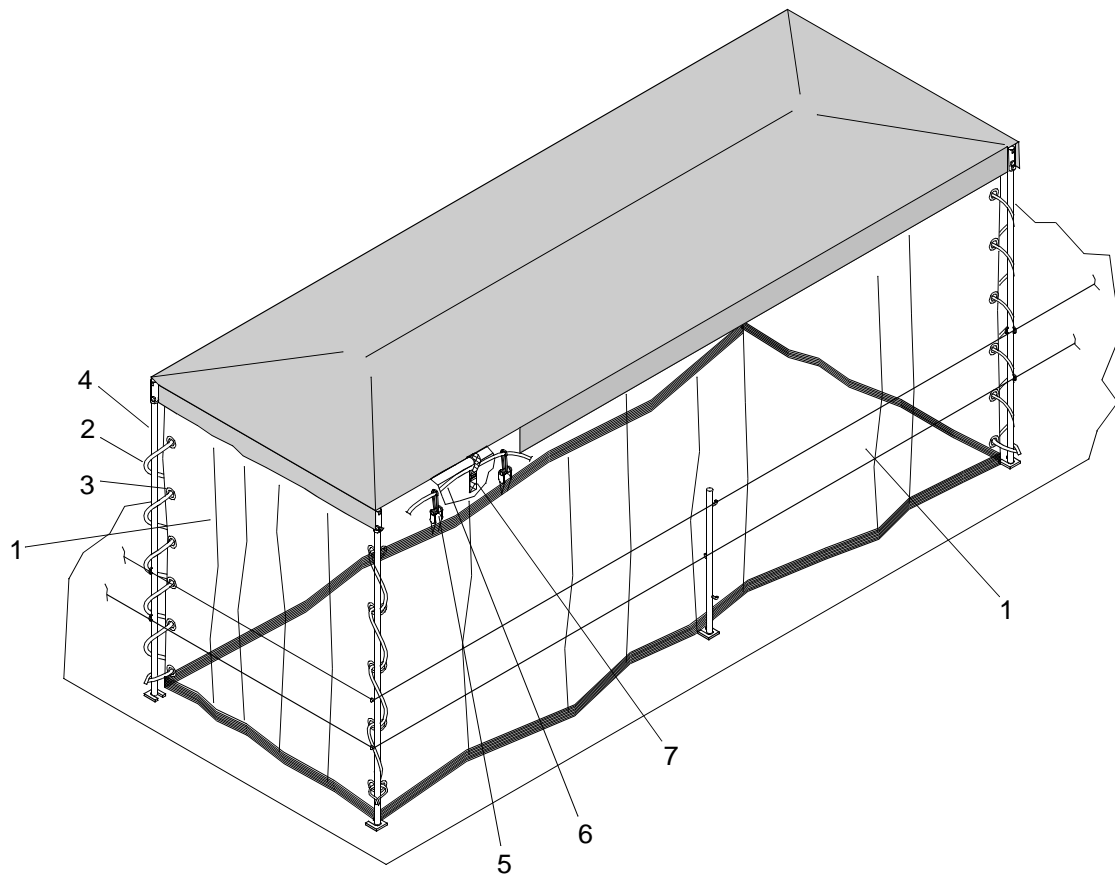
PREPARATION FOR MOVEMENT - REMOVE CREW SHELTER

WARNING

**VEST****HELMET PROTECTION****HEAVY PARTS****MOVING PARTS**

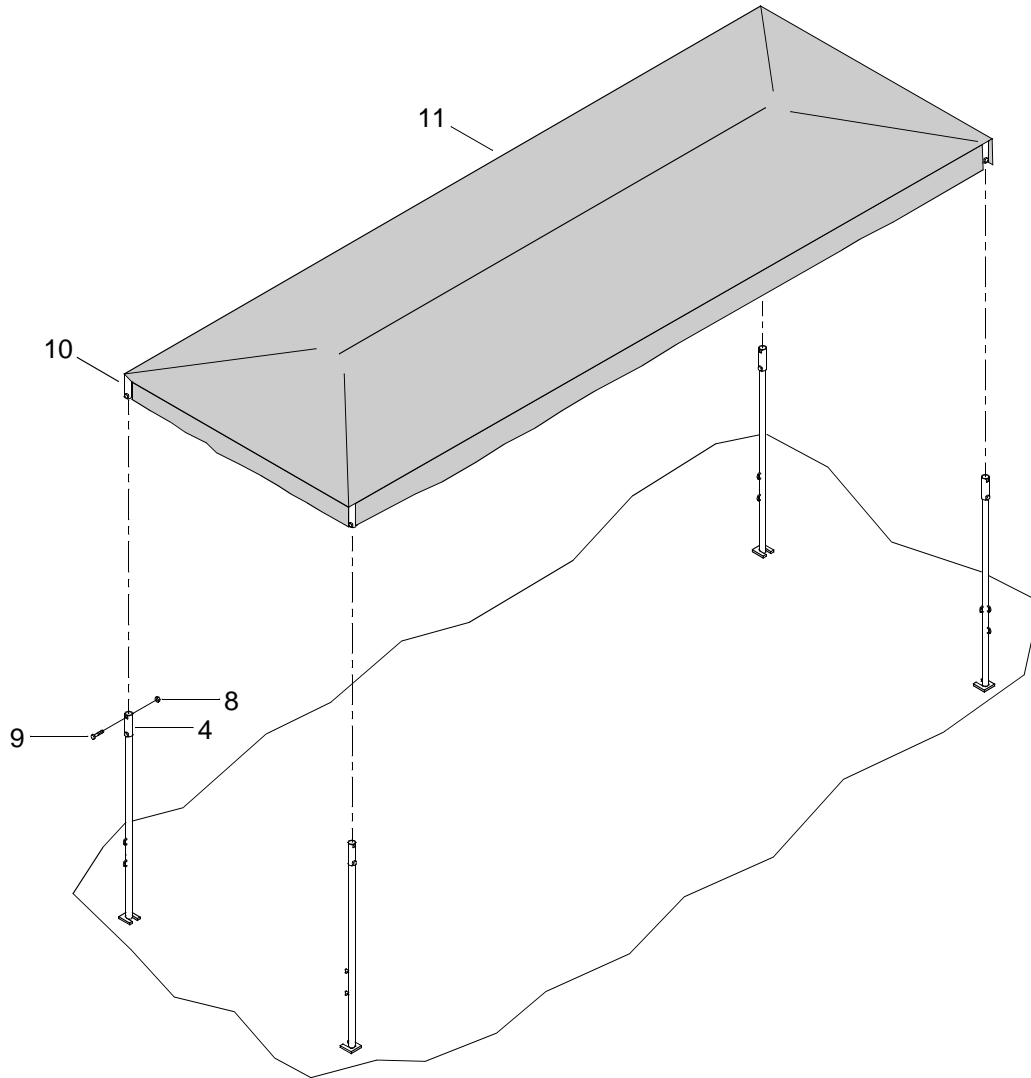
All personnel must wear personal flotation device, hard hat, safety shoes and gloves during CF operations and maintenance. Failure to observe these precautions could result in serious injury or death.

1. Unfasten all panels (1).



- a. Remove line (2) securing panel grommets (3) to stanchions (4). Discard line (2).
 - b. Unsnap panel hooks (5) from canopy line (6).
 - c. Using assistant, fold all panels (1).
2. Remove canopy line (6) from tiedown straps (7). Discard canopy line (6).

3. Remove hex head nuts (8) and carriage bolts (9) securing canopy connection legs (10) to stanchions (4).



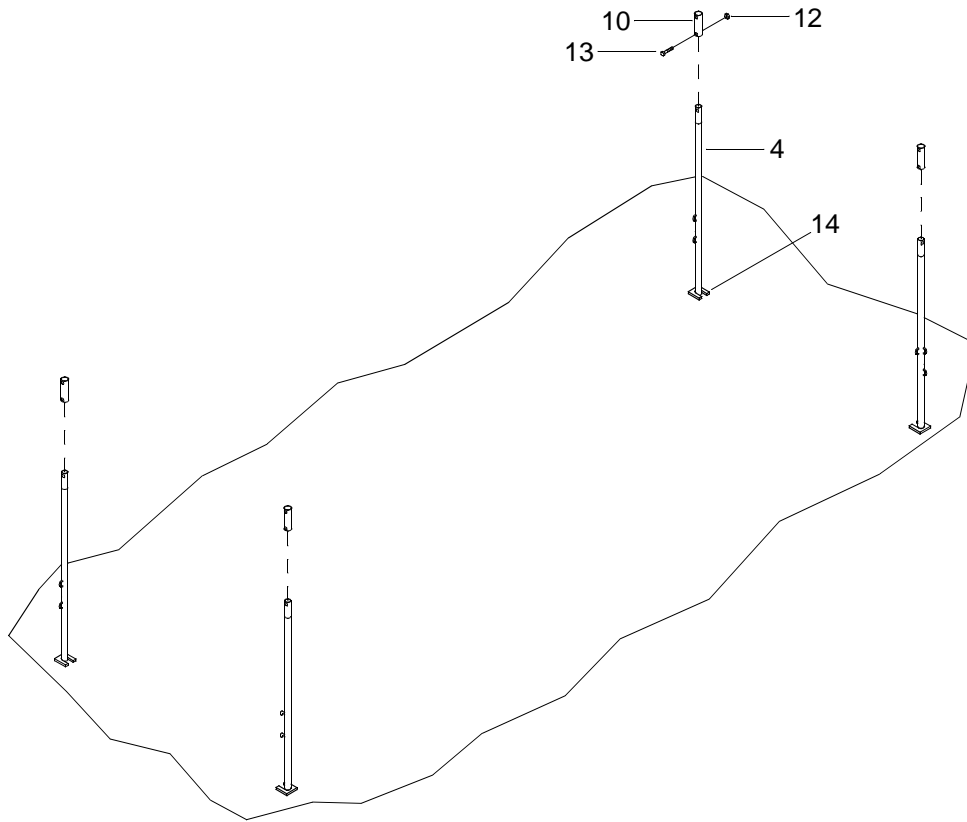
WARNING



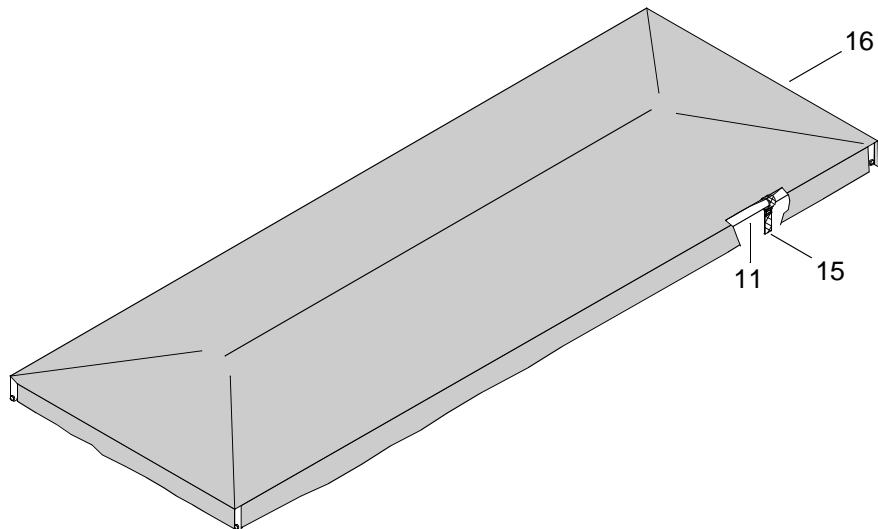
HEAVY OBJECTS

4. Using assistant, remove canopy with frame (11) from stanchions (4).

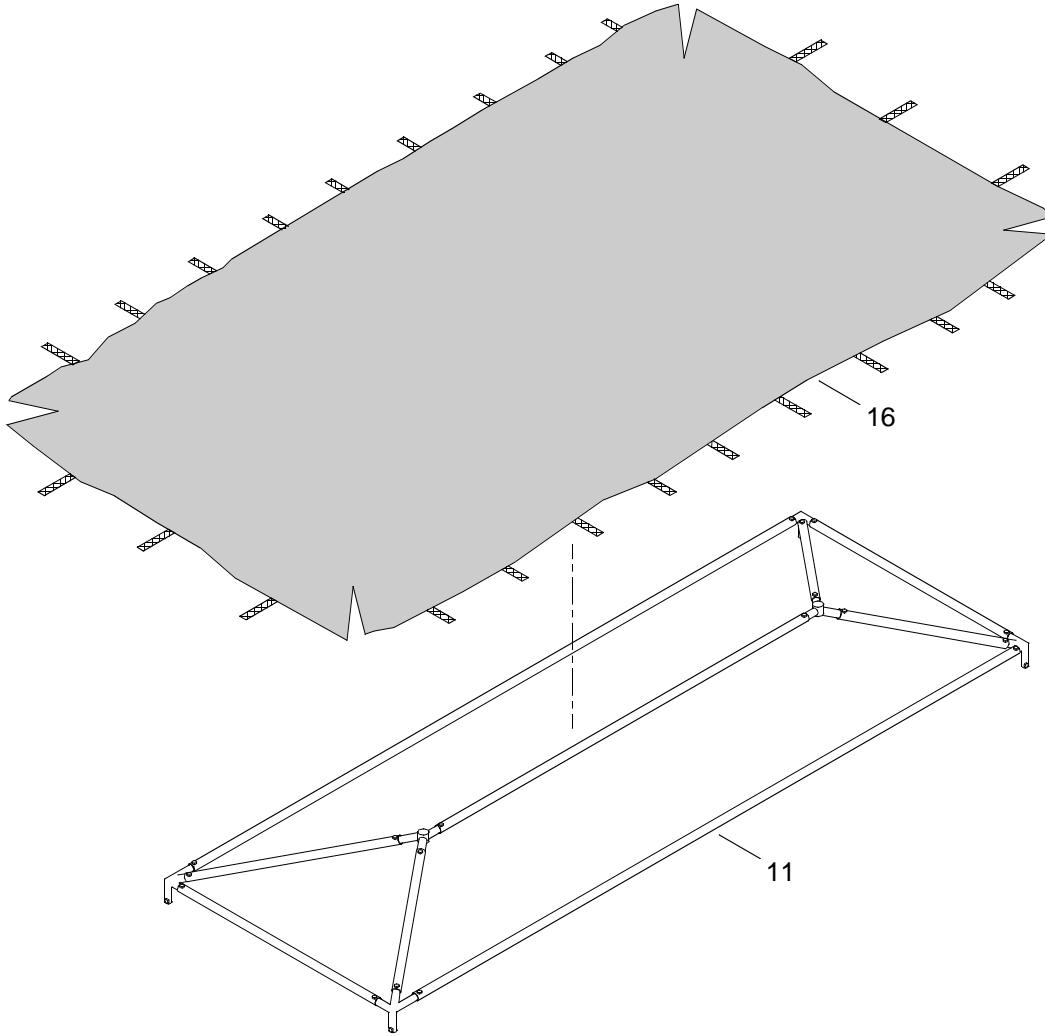
5. Remove hex head nuts (12) and carriage bolts (13) securing canopy connection legs (10) to stanchions (4).



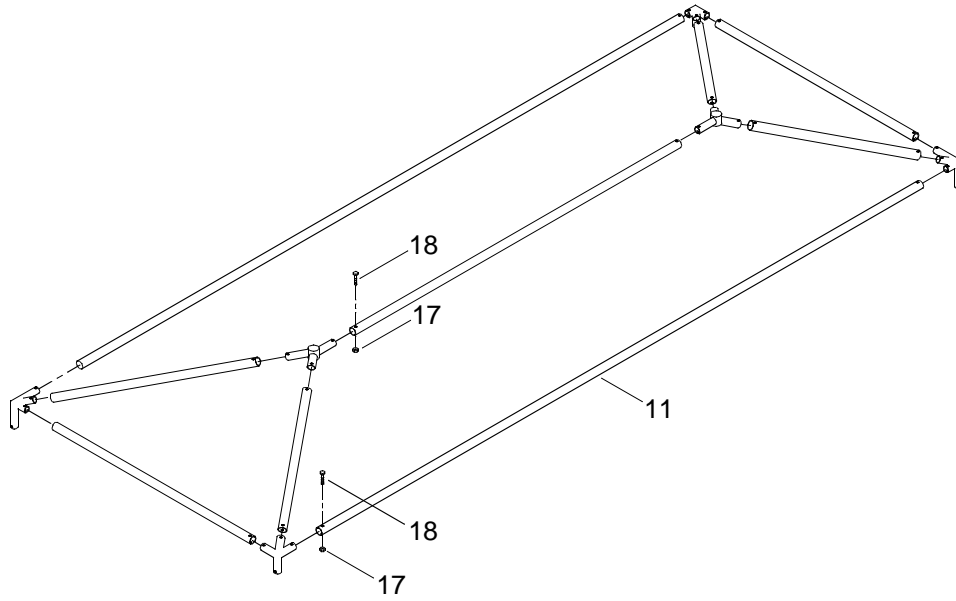
6. Remove canopy connection legs (10) from stanchions (4).
7. Remove stanchions (4) from deck fittings (14).
8. Release tiedown straps (15) securing canopy (16) to frame (11).



9. Using assistant, remove canopy (16) from frame (11) and fold canopy (16).



10. Remove all hex head nuts (17) and carriage bolts (18) from frame (11).



11. Separate all components of frame (11).

12. Stow all crew shelter components in BII container.

END OF WORK PACKAGE

**OPERATOR MAINTENANCE
CAUSEWAY FERRY
SAFETY EQUIPMENT
OPERATION UNDER USUAL CONDITIONS**

INITIAL SETUP:

Tools

- Tool Kit, General Mechanic's (Rail and Marine) (Item 76, WP 0105 00)
- Gloves, Men's and Women's (Leather Palm) (Item 31, WP 0105 00)
- Goggles, Sun, Wind and Dust (Safety) (Item 34, WP 0105 00)
- Life Preserver, Vest (Item 45, WP 0105 00)
- Helmet, Safety (Brown) (Item 40, WP 0105 00)

Personnel Required

Seaman 88K

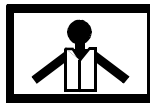
Equipment Condition

Crew Shelter Removed. (WP 0035 20)

PREPARATION FOR MOVEMENT - REMOVAL OF SAFETY EQUIPMENT

REMOVAL OF PORTABLE FIRE EXTINGUISHER

WARNING



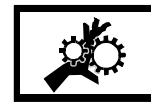
VEST



HELMET PROTECTION



HEAVY PARTS



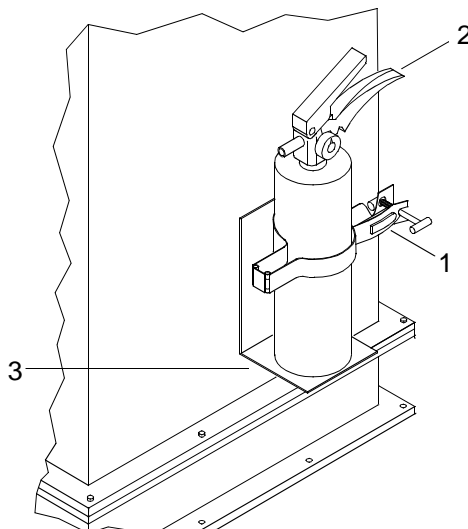
MOVING PARTS

All personnel must wear personal flotation device, hard hat, safety shoes and gloves during CF operations and maintenance. Failure to observe these precautions could result in serious injury or death.

NOTE

All removed equipment will be stowed in the BII ISO container.

1. Open latch clamp (1) securing portable CO2 fire extinguisher (2) to bracket (3).



2. Remove extinguisher (3).
3. Close and lock latch clamp (1).
4. Stow portable CO2 fire extinguisher (2) in BII container.

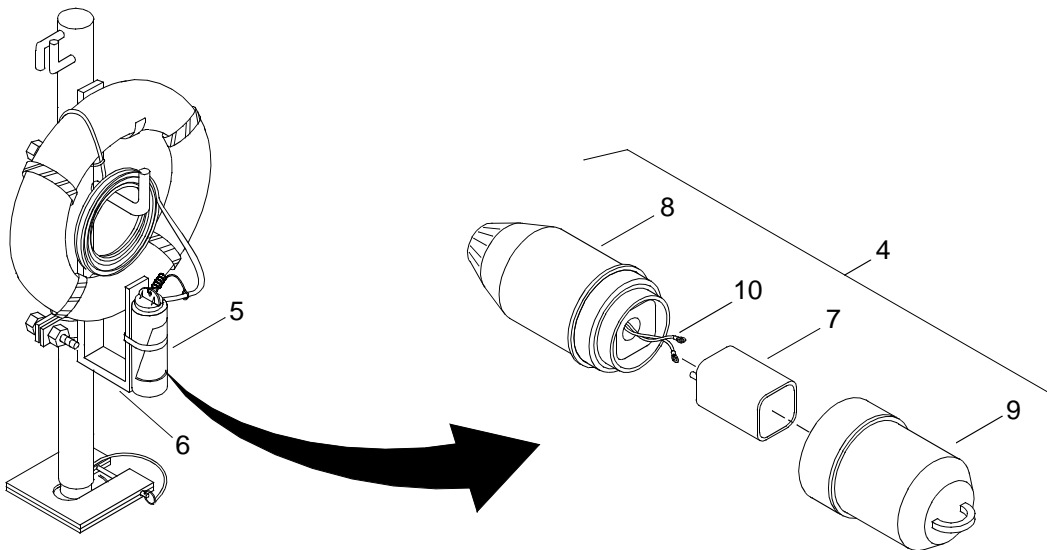
LIFE RING STROBE LIGHT BATTERY REMOVAL

1. Remove life ring strobe light assembly (4) from strobe light holder (5) on life ring bracket (6).

NOTE

This procedure is typical for the removal of strobe light batteries from the life ring strobe lights.

2. Remove strobe light batteries (7) from life ring strobe light assemblies (4).

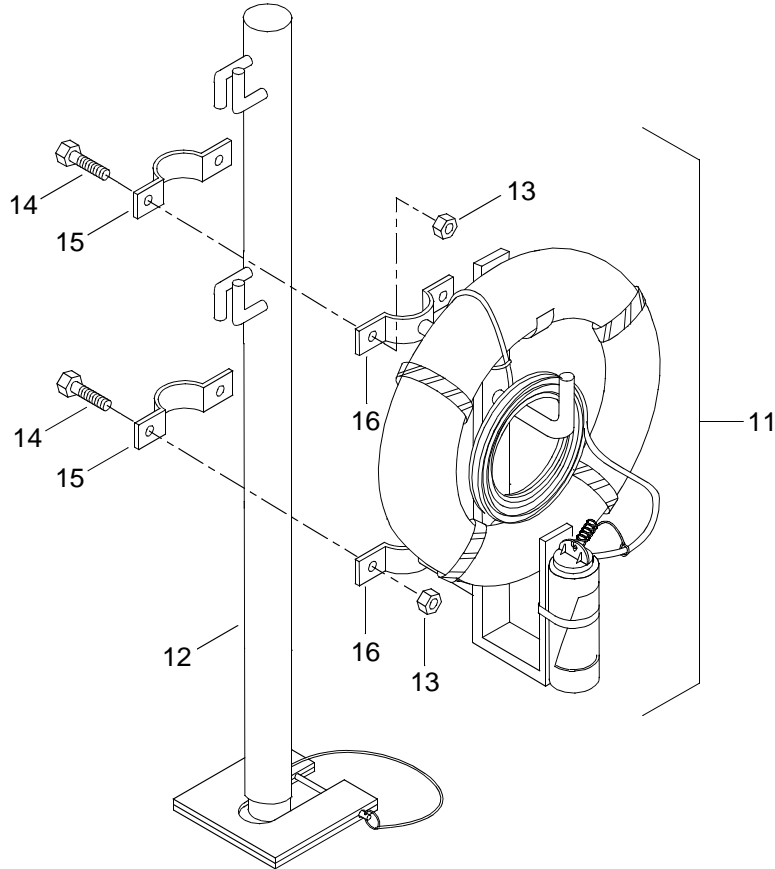


- a. Unscrew strobe light housing (8) from strobe light base (9).
- b. Disconnect two battery wires (10) from battery (7).
- c. Remove battery (7) from strobe light base (9).
- d. Screw strobe light housing (8) and strobe light base (9) together.
- e. Stow battery (7) in BII container.

REMOVAL OF LIFE RINGS**NOTE**

This procedure is typical for the removal of life ring assemblies from side stanchions.

1. Remove life ring assembly (11) from stanchion (12).

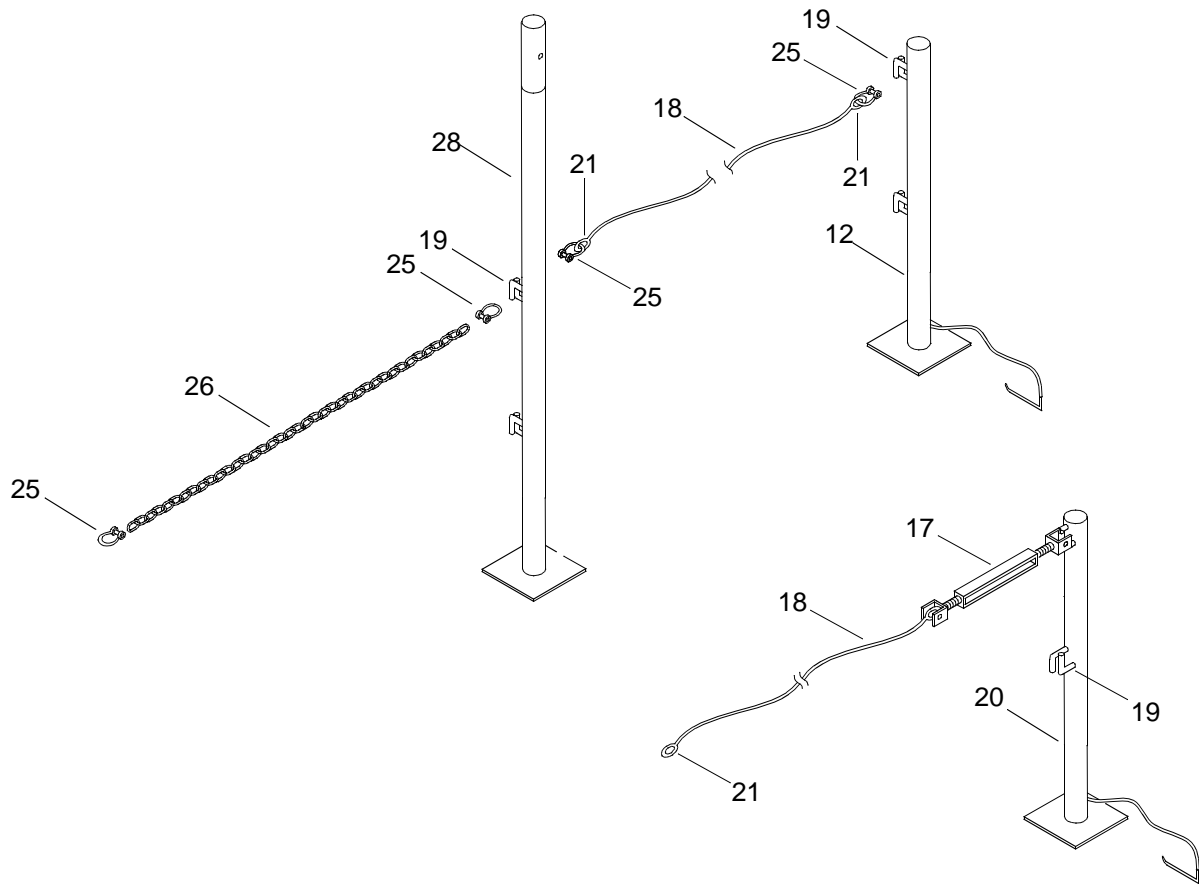


- a. Remove nuts (12), bolts (13) and outer clamps (14) from inner clamp (15) securing life ring assembly (10) to stanchion (12).
 - b. Remove life ring assembly (10) from stanchion (12).
 - c. Install outer clamp (15), bolts (14) and nuts (13) on inner clamp (16). Tighten nuts (13).
2. Stow life ring assembly (11) in BII ISO container.

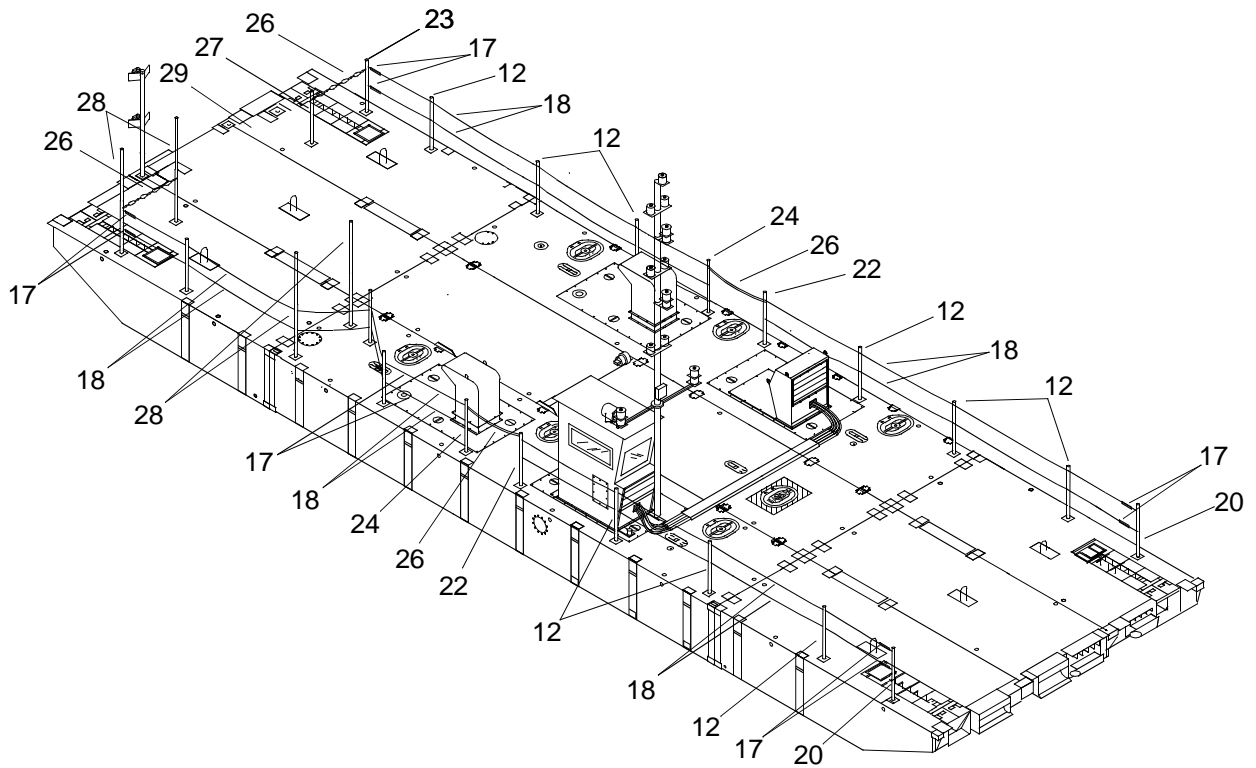
REMOVAL OF LIFELINES**NOTE**

This procedure is typical for removal of lifelines and stanchions.

1. Loosen and remove turnbuckles (17), securing side lifelines (18) to cable guides (19), from forward stanchions (20).



2. Remove side lifelines (18) from cable guides (19) on side stanchions (12).



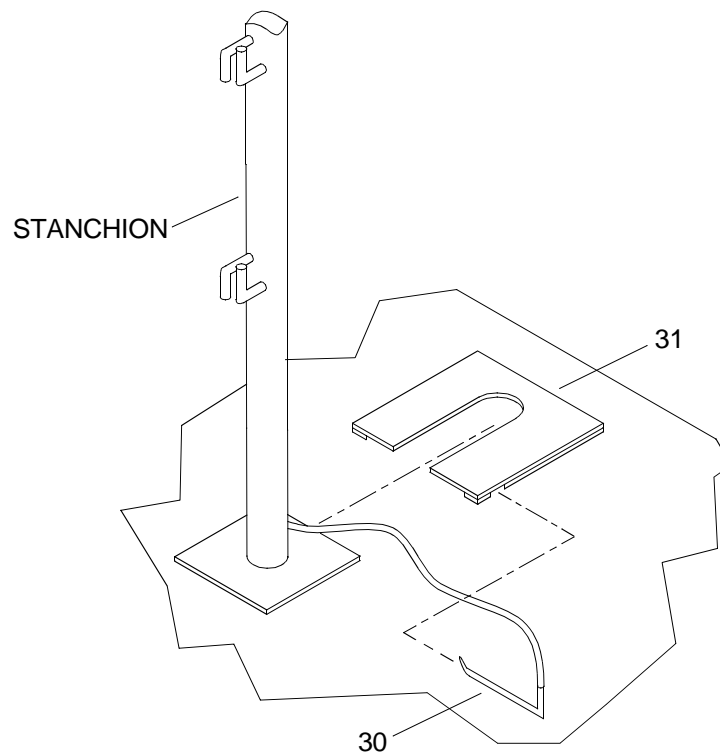
3. Remove lifeline ends (20) securing side lifelines (18) to center stanchions (22).
4. Loosen and remove turnbuckles (17) securing port side lifelines (18) to aft corner stanchion (23).
5. Remove lifelines (18) from cable guides (19) on side stanchions (12).
6. Remove lifeline ends (21) from port center stanchion (24).
7. Remove shackles (25) securing chains (26) to port stern (27) and corner (23) stanchions.
8. Remove shackles (25) securing chains (26) to starboard stern canopy stanchions (28).
9. Remove shackles (25) securing stern lifeline (29) to canopy stanchion (28) and port stern stanchion (27).
10. Loosen and remove turnbuckles (17) securing starboard lifelines (18) to corner canopy stanchion (28).
11. Remove lifeline ends (21) from starboard center stanchion (24).
12. Remove turnbuckles (17) connecting sections of lifelines (18).
13. Stow lifelines (15 and 29), chains (26) and all connecting hardware in BII container.

REMOVE STANCHIONS

NOTE

This procedure is typical for the removal of all stanchions.

1. Remove pins (30) from deck fittings (31) of stanchions (12, 20, 22, 23, 24, 26 and 28).



2. Remove stanchions (12, 20, 22, 23, 24, 26 and 28) from deck fittings (31).
3. Stow all stanchions (12, 20, 22, 23, 24, 26 and 28) in BII container.

END OF WORK PACKAGE

**OPERATOR MAINTENANCE
CAUSEWAY FERRY
FENDERS
OPERATION UNDER USUAL CONDITIONS**

INITIAL SETUP:**Tools**

Tool Kit, General Mechanic's (Rail and Marine) (Item 76, WP 0105 00)
 Gloves, Men's and Women's (Leather Palm) (Item 31, WP 0105 00)
 Goggles, Sun, Wind and Dust (Safety) (Item 34, WP 0105 00)
 Life Preserver, Vest (Item 45, WP 0105 00)
 Helmet, Safety (Brown) (Item 40, WP 0105 00)
 2-Ton, ½ in. Anchor Shackle (Item 1, WP 0105 00)
 Qty 4
 Sling, Lifting, 5,300 (Green) (Item 68, WP 0105 00)
 Qty 4
 Crowbar (Item 15, WP 0105 00)
 Hammer, Hand (10 lb Sledge) (Item 36, WP 0105 00)

Personnel Required

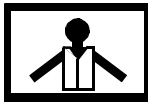
Seaman 88K (2)

Equipment Condition

Safety Equipment Removed. (WP 0036 00)

PREPARATION FOR MOVEMENT - REMOVAL OF FENDERS

WARNING



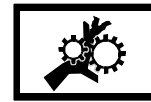
VEST



HELMET PROTECTION



HEAVY PARTS



MOVING PARTS

All personnel must wear personal flotation device, hard hat, safety shoes and gloves during CF operations and maintenance. Failure to observe these precautions could result in serious injury or death.

REMOVE PROPULSION MODULE SIDE FENDERS**NOTE**

This procedure is typical for removal of side fenders on both port and starboard sides of powered section.

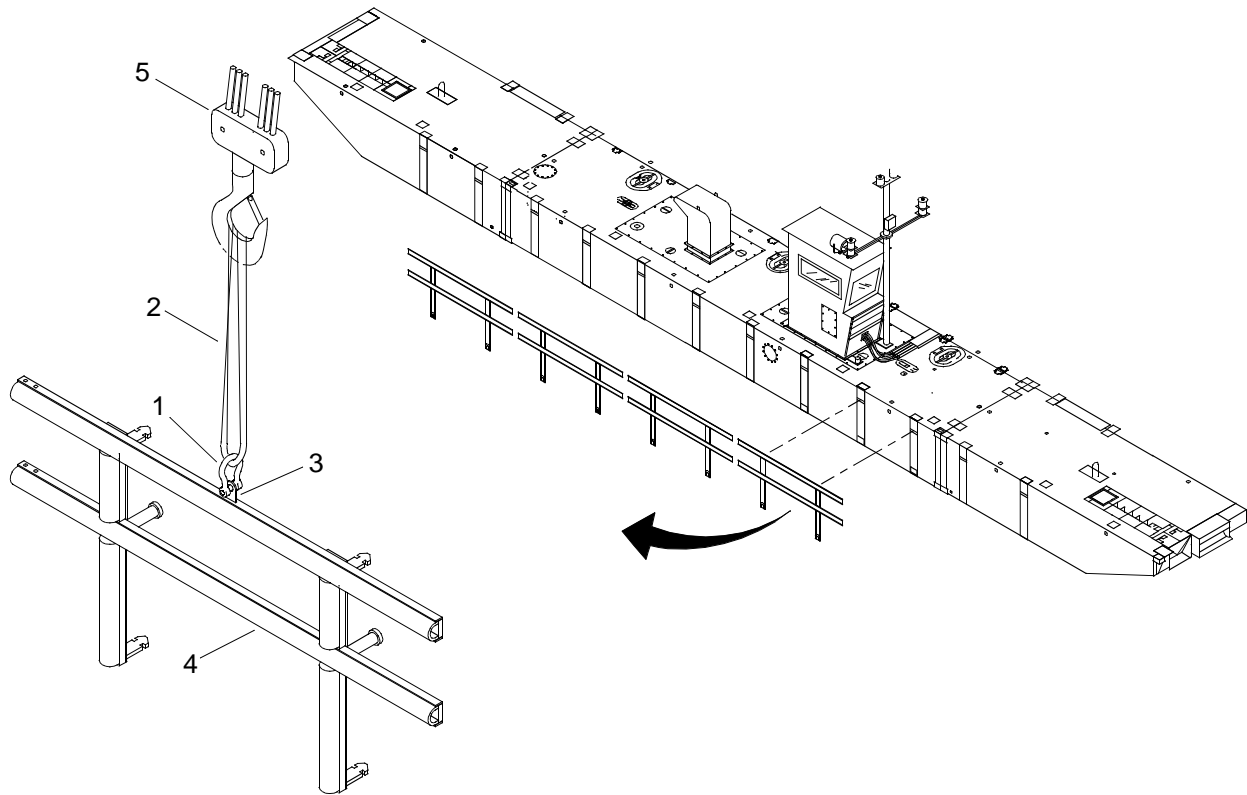
If powered section is to be disassembled in water, this task is to be accomplished after modules are separated and removed from water.

1. Attach 2-ton shackle (1) and 5,300 lb sling (2) to lifting pad (3) of side fender (4).
2. Attach 5,300 lb sling (2) to crane (5).

WARNING

**HEAVY PARTS**

3. Using crane and slings to support side fender assembly (4), raise all outboard guillotine connectors. (WP 0008 00)



WARNING

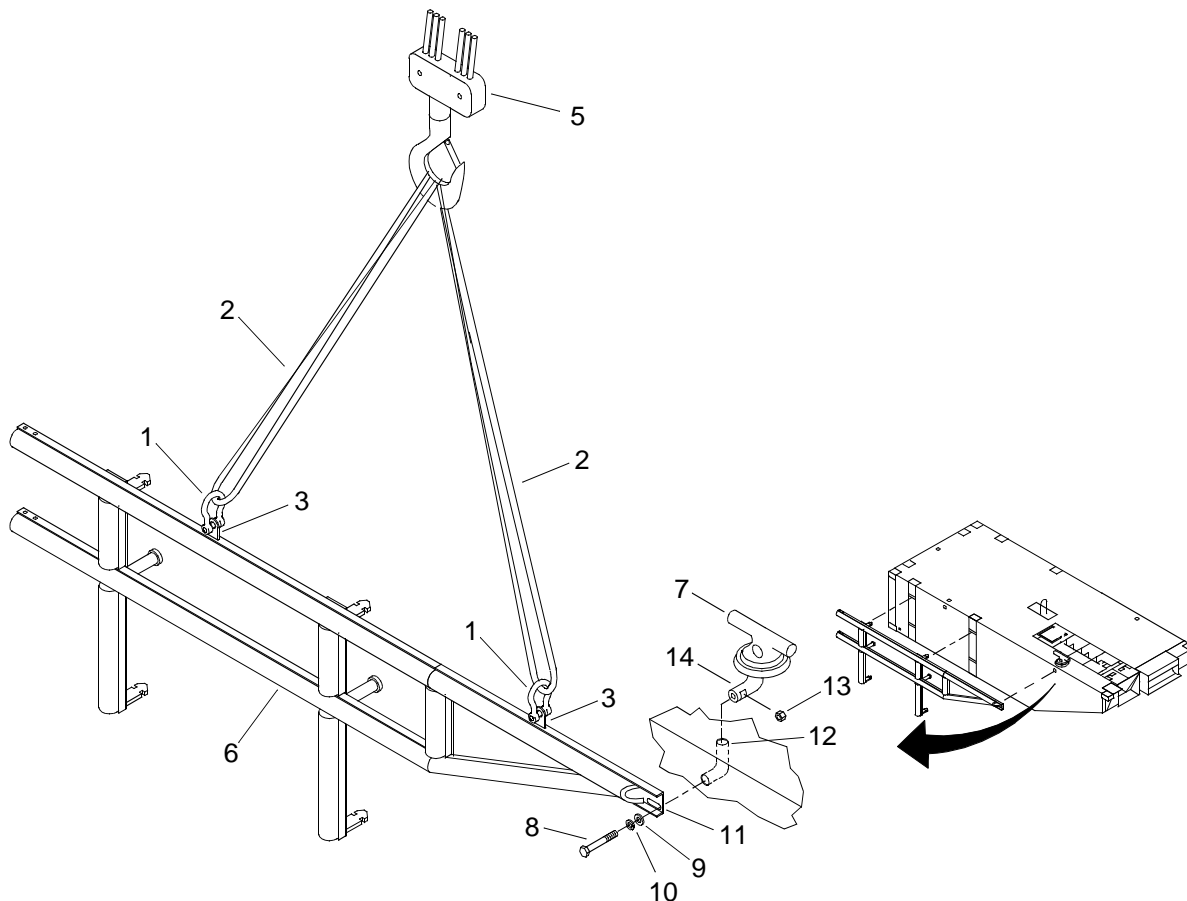
**HEAVY PARTS**

5. Remove side fender (4) and position for stowage.
6. Remove shackle (1), sling (2) and crane (5) from side fender (4).
7. Remove sling (2) from crane (5).

REMOVE END RAKE SIDE FENDERS**NOTE**

This procedure is typical for removal of end rake side fenders on both port and starboard sides of propulsion module.

1. Attach 2-ton shackle (1) and 5,300 lb sling (2) to lifting pad (3) of forward/aft side fender (6).



2. Use crane and sling to support forward/aft fenders (6) during removal.
3. Remove deck cleat (7) and hardware from forward/aft side fender (6).
 - a. Loosen bolt (8) in forward/aft side fender end (9) and the deck cleat fitting (7).
 - b. Remove bolt (8) with washers (10 and 11) from forward/aft side fender end (9) and turn tube (12).
 - c. Remove deck cleat (7).
 - d. Remove nut (13) from deck cleat tailpiece (14).
4. Lower all outboard guillotine connectors. (WP 0008 00)

WARNING

**HEAVY PARTS**

5. Using crane and sling, remove forward/aft side fender (6) and position for stowage.
6. Remove shackle (1), sling (2) and crane (5) from forward/aft side fender (6).
7. Rinse all side fender components with fresh water and allow to air dry.
8. Stow side fender components. (WP 0060 10)

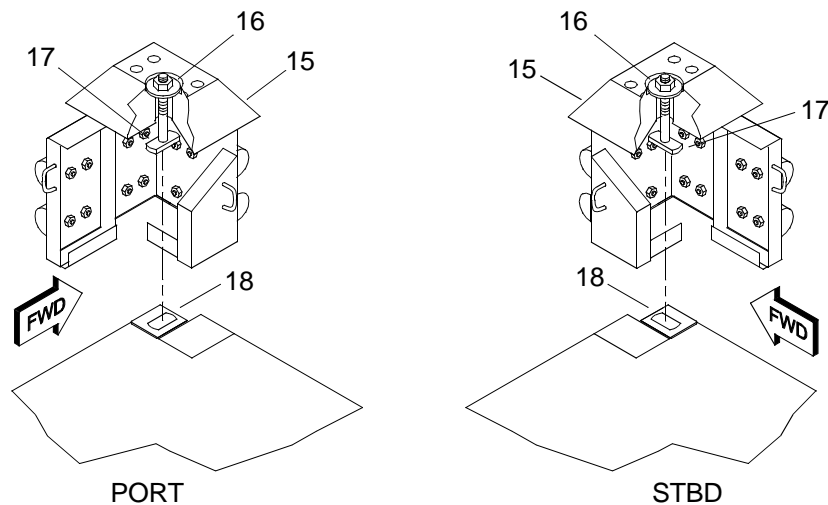
REMOVE CORNER FENDERS**NOTE**

This task is typical for removal of corner fenders.

There are two configurations of corner fenders, left hand (port) and right hand (starboard).

Fenders are stored with tee bolt, washer and nut installed in fenders.

1. Attach tag line to corner fender (15) and secure to deck.
2. Remove corner fender (15).



- a. Loosen nut (16), but do not remove.

-
- b. Turn tee bolt (17) ¼ turn in ISO fitting (18).

WARNING



HEAVY OBJECTS

- c. Using an assistant, remove corner fender (15) from ISO fitting (18).
3. Rinse corner fenders (15) with fresh water and allow to air dry.
4. Stow corner fenders (15) in BII container.

END OF WORK PACKAGE

**OPERATOR MAINTENANCE
CAUSEWAY FERRY
D-RING/CLOVERLEAF AND DECK CLEAT FITTINGS
OPERATION UNDER USUAL CONDITIONS**

INITIAL SETUP:**Tools**

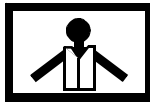
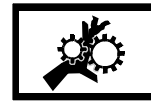
Tool Kit, General Mechanic's (Rail and Marine) (Item 76, WP 0105 00)
 Gloves, Men's and Women's (Leather Palm) (Item 31, WP 0105 00)
 Goggles, Sun, Wind and Dust (Safety) (Item 34, WP 0105 00)
 Life Preserver, Vest (Item 45, WP 0105 00)
 Helmet, Safety (Brown) (Item 40, WP 0105 00)

Personnel Required

Seaman 88K

PREPARATION FOR MOVEMENT - REMOVAL OF D-RING/CLOVERLEAF AND DECK CLEAT FITTINGS**REMOVE D-RING/CLOVERLEAF FITTINGS**

WARNING

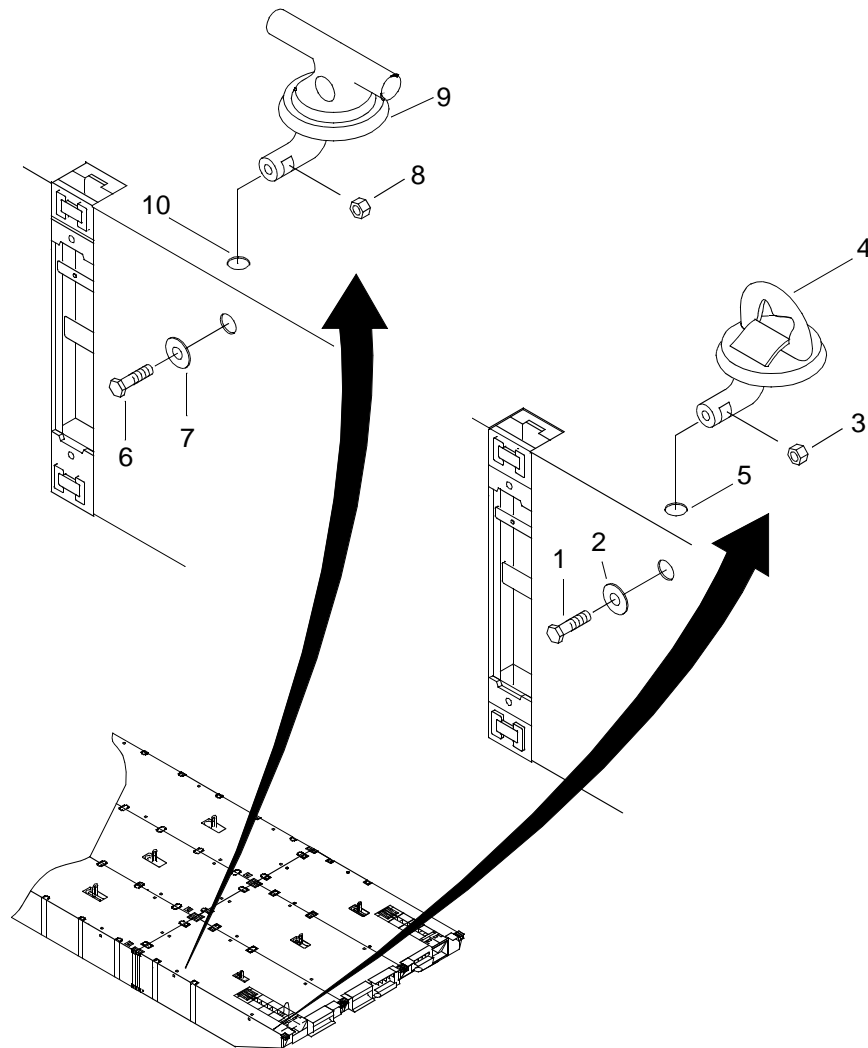
**VEST****HELMET PROTECTION****HEAVY PARTS****MOVING PARTS**

All personnel must wear personal flotation device, hard hat, safety shoes and gloves during CF operations and maintenance. Failure to observe these precautions could result in serious injury or death.

Beware of other craft or objects coming alongside while working outboard removing the bolt and washer. Serious injury may result if body parts are crushed between module and other craft or objects.

Use extreme caution while working outboard and lifting heavy objects as the possibility of falling overboard exists, which could cause serious injury or death.

1. Remove bolt (1) with keeper plate (2) from nut (3).



2. Remove D-ring/cloverleaf (4) with nut (3) from module turn tube (5).
3. Install bolt (1) through keeper plate (2) and thread into nut (3) in D-ring/cloverleaf (4).
4. Stow D-ring/cloverleaf (4) assemblies in BII ISO container. (WP 0060 00)

REMOVE DECK CLEAT FITTINGS

WARNING

Beware of other craft or objects coming alongside while working outboard removing the bolt and washer. Serious injury may result if body parts are crushed between module and other craft or objects.

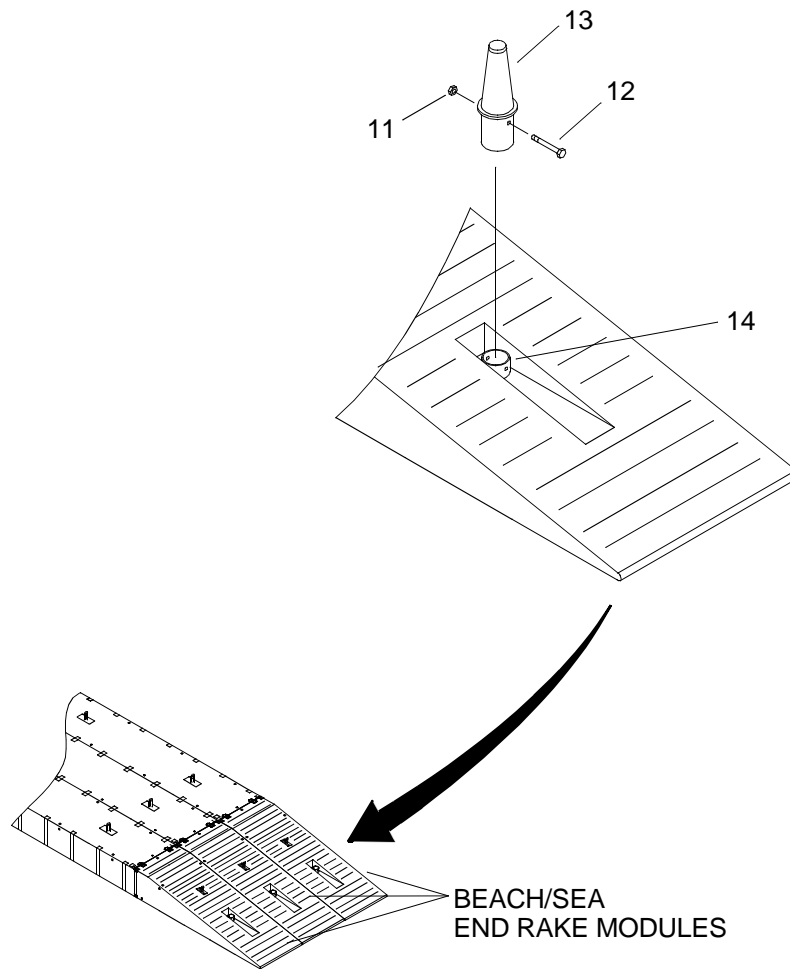
Use extreme caution while working outboard and lifting heavy objects as the possibility of falling overboard exists, which could cause serious injury or death.

1. Remove bolt (6) with keeper plate (7) from nut (8).
2. Remove deck cleat (9) with nut (8) from module turn tube (10).

3. Install bolt (6) with keeper plate (7) and thread into nut (8) in deck cleat (9).
4. Stow deck cleat (9) assemblies in BII ISO container. (WP 0060 00)

REMOVE RHINO HORN

1. Remove nut (11) from the bolt (12).
2. Remove bolt (12) from the rhino horn (13) and module fitting (14).
3. Remove rhino horn (13) from the beach/sea end rake module fitting (14).



END OF WORK PACKAGE

**OPERATOR MAINTENANCE
CAUSEWAY FERRY
BOW STUB MAST
OPERATION UNDER USUAL CONDITIONS**

INITIAL SETUP:

Tools

- Tool Kit, General Mechanic's (Rail and Marine) (Item 76, WP 0105 00)
- Gloves, Men's and Women's (Leather Palm) (Item 31, WP 0105 00)
- Goggles, Sun, Wind and Dust (Safety) (Item 34, WP 0105 00)
- Life Preserver, Vest (Item 45, WP 0105 00)
- Helmet, Safety (Brown) (Item 40, WP 0105 00)

Materials/Parts

- Shoring Blocks (Item 21, WP 0106 00)
- Qty 2

Personnel Required

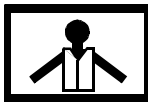
- Seaman 88K (2)

Equipment Condition

- Safety Equipment Removed. (WP 0036 00)
 - Fenders Removed. (WP 0037 00)
 - D-Ring/Cloverleaf Fittings And Deck Cleat Fittings Removed. (WP 0038 00)
-

PREPARATION FOR MOVEMENT - BOW STUB MAST REMOVAL

WARNING



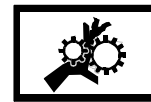
VEST



HELMET PROTECTION



HEAVY PARTS

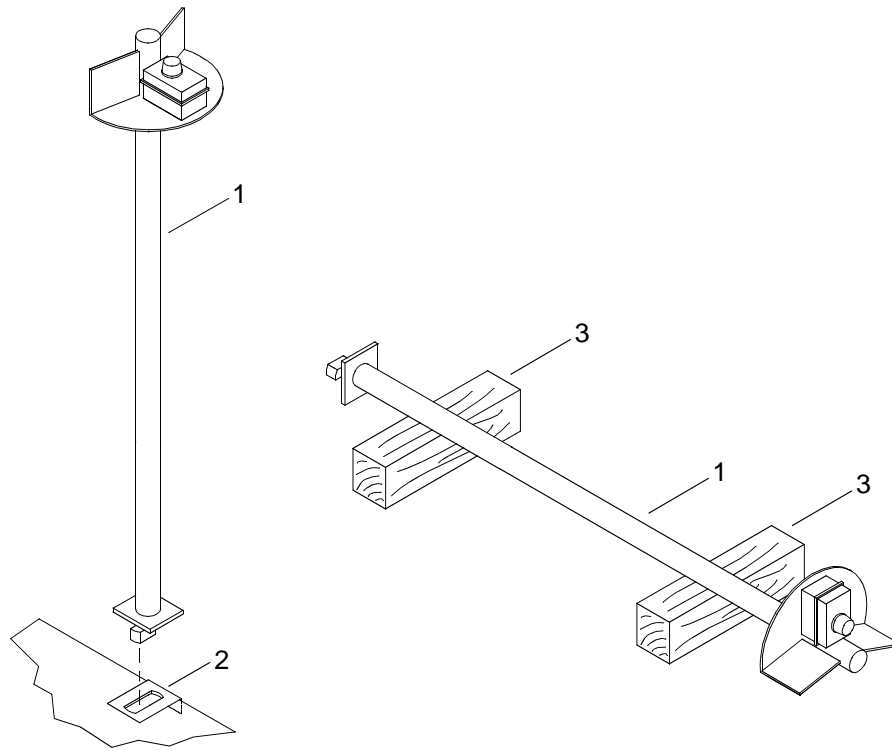


MOVING PARTS

All personnel must wear personal flotation device, hard hat, safety shoes and gloves during CF operations and maintenance. Failure to observe these precautions could result in serious injury or death.

REMOVE BOW STUB MAST

1. Remove bow stub mast (1).



- a. Rotate bow stub mast (1) 90° in ISO fitting (2).

WARNING

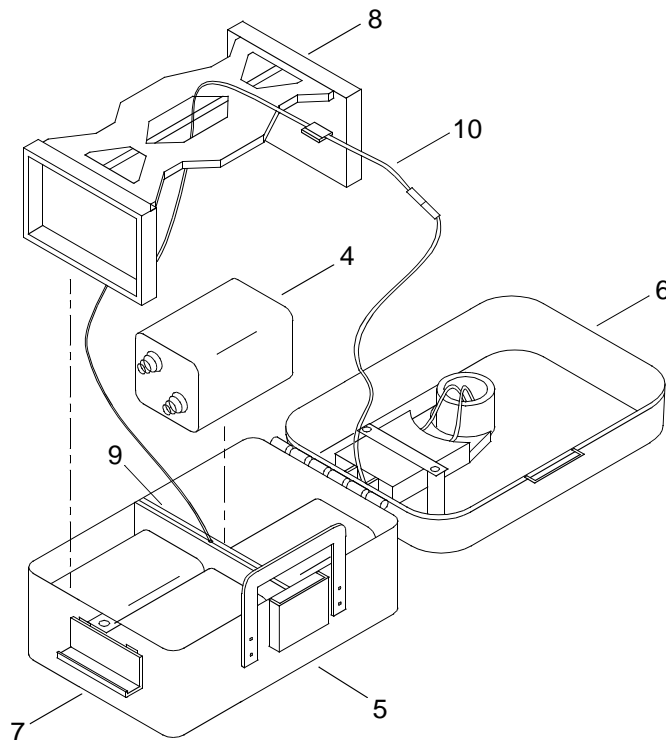


HEAVY OBJECTS

- b. Using an assistant, remove base of the bow stub mast (1) from ISO fitting (2).
2. Position bow stub mast (1) on shoring blocks (3).

REMOVE BATTERIES FROM BOW STUB MAST LIGHT

1. Remove batteries (4) from bow stub mast light (5).



- a. Open light cover (6) by unlatching clasp (7).
 - b. Remove battery bracket (8).
 - c. Remove conductor plate (9).
 - d. Remove batteries (4) from bow stub mast light case (5).
 - e. Install conductor plate (9).
 - f. Install battery bracket (8).
 - g. Position wire (10) away from edges of bow stub mast light case (5).
 - h. Close light cover (6) and latch clasp (7).
2. Stow bow stub mast (1) and batteries (4). (WP 0060 20)

END OF WORK PACKAGE

**OPERATOR MAINTENANCE
CAUSEWAY FERRY
STUB NAVIGATION MAST
OPERATION UNDER USUAL CONDITIONS**

INITIAL SETUP:**Tools**

Tool Kit, General Mechanic's (Rail and Marine) (Item 76, WP 0105 00)
 Gloves, Men's and Women's (Leather Palm) (Item 31, WP 0105 00)
 Goggles, Sun, Wind and Dust (Safety) (Item 34, WP 0105 00)
 Life Preserver, Vest (Item 45, WP 0105 00)
 Helmet, Safety (Brown) (Item 40, WP 0105 00)

Materials/Parts

Shoring Blocks (Item 21, WP 0106 00)
 Qty 2

Personnel Required

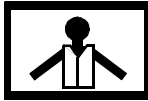
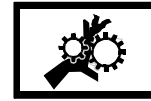
Seaman 88K (2)

Equipment Condition

Fenders Removed. (WP 0037 00)
 D-Ring/Cloverleaf Fittings And Deck Cleat Fittings Removed. (WP 0038 00)

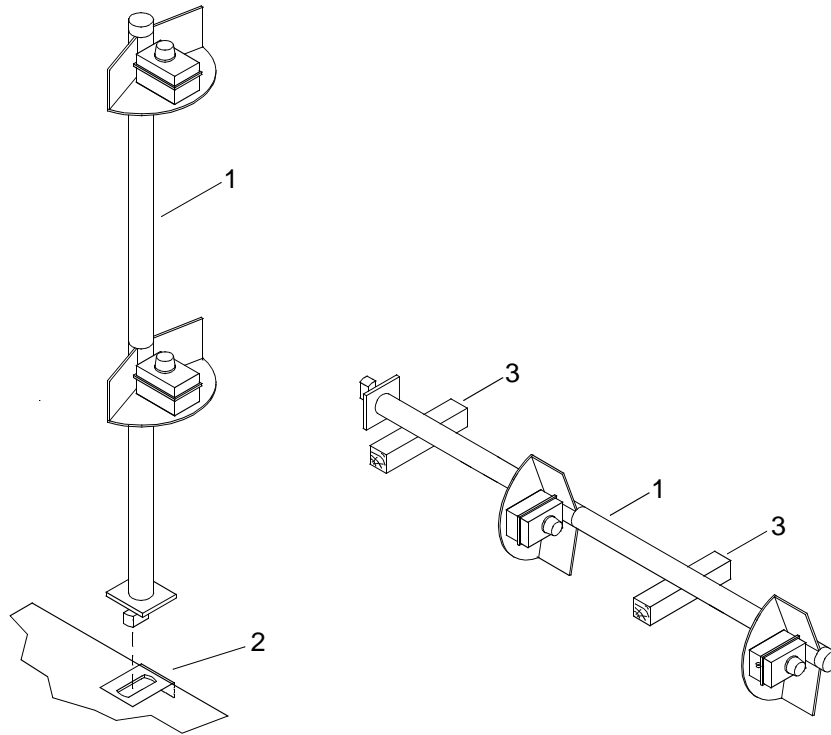
PREPARATION FOR MOVEMENT - REMOVE STUB NAVIGATION MAST

WARNING

**VEST****HELMET PROTECTION****HEAVY PARTS****MOVING PARTS**

All personnel must wear personal flotation device, hard hat, safety shoes and gloves during CF operations and maintenance. Failure to observe these precautions could result in serious injury or death.

1. Using assistant, remove stub mast (1).



- a. Rotate stub mast (1) 90° in ISO fitting (2).

WARNING



HEAVY PARTS

- b. Remove base of the stub mast (1) from corner ISO fitting (2).

WARNING



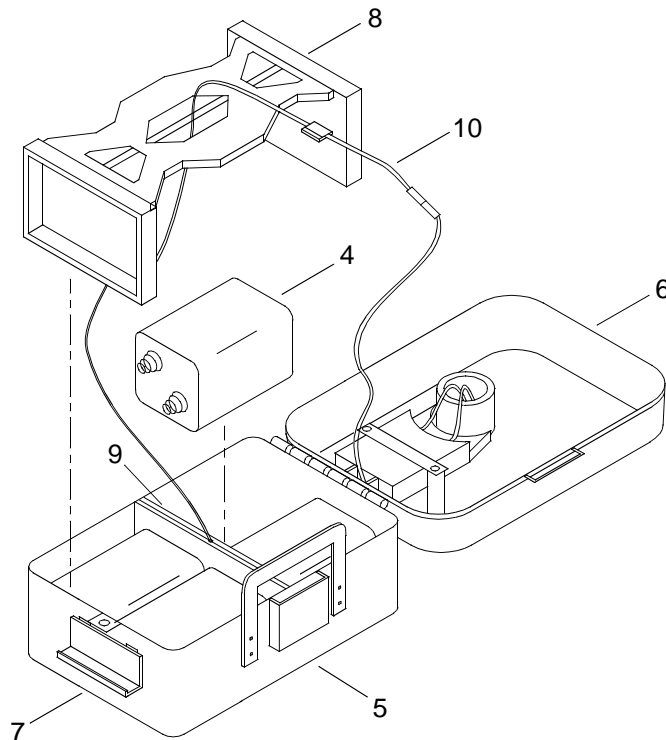
HEAVY PARTS

- c. Place stub mast (1) on shoring blocks (3).

NOTE

This procedure is typical for removal of the stub navigation mast light batteries.

2. Remove batteries (4) from stub mast lights (5).



- a. Open light cover (6) by unlatching clasp (7).
 - b. Remove battery bracket (8).
 - c. Remove conductor plate (9).
 - d. Remove batteries (4) from stub mast light case (5).
 - e. Install conductor plate (9).
 - f. Install battery bracket (8).
 - g. Position wire (10) away from edges of stub mast light case (5).
 - h. Close light cover (6) and latch clasp (7).
3. Stow stub mast (1) on lower main mast brackets. (WP 0041 00)

END OF WORK PACKAGE

**OPERATOR MAINTENANCE
CAUSEWAY FERRY
ANCHORBOARD ASSEMBLY
OPERATION UNDER USUAL CONDITIONS**

INITIAL SETUP:

Tools

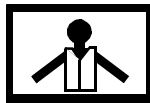
- Tool Kit, General Mechanic's (Rail and Marine) (Item 76, WP 0105 00)
- Gloves, Men's and Women's (Leather Palm) (Item 31, WP 0105 00)
- Goggles, Sun, Wind and Dust (Safety) (Item 34, WP 0105 00)
- Life Preserver, Vest (Item 45, WP 0105 00)
- Helmet, Safety (Brown) (Item 40, WP 0105 00)
- Sling, Lifting 5300 lbs (Green) (Item 69, WP 0105 00)
- 4 ¾ Ton ¾ in. Shackle (Item 5, WP 0105 00)

Personnel Required

Seaman 88K

PREPARATION FOR MOVEMENT - REMOVAL OF ANCHORBOARD ASSEMBLY

WARNING



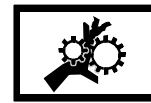
VEST



HELMET PROTECTION



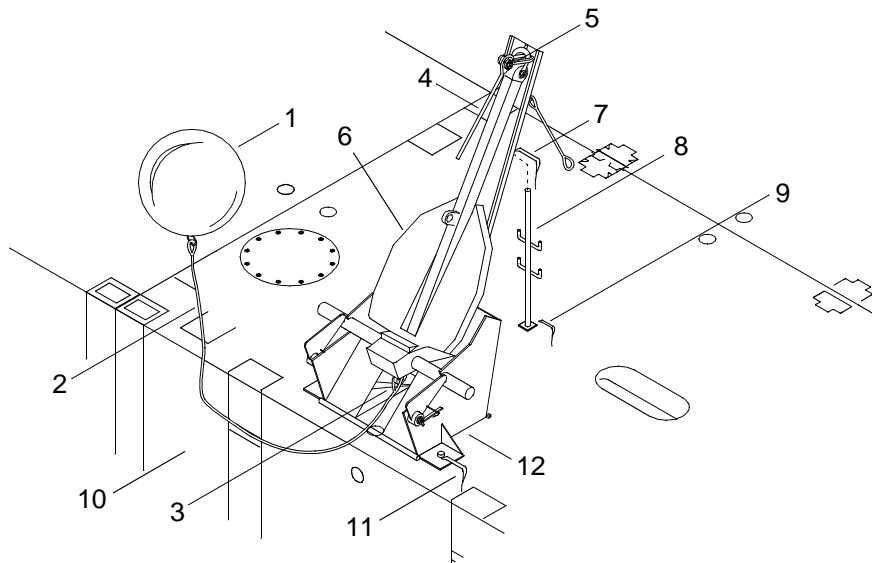
HEAVY PARTS



MOVING PARTS

All personnel must wear personal flotation device, hard hat, safety shoes and gloves during CF operations and maintenance. Failure to observe these precautions could result in serious injury or death.

1. Remove buoy (1) from buoy line (2).



2. Remove buoy line (2) from base anchor shackle (3).

3. Remove anchor rope (4) from anchor top shackle (5).
4. Using crane, sling and shackle, attach sling to anchorboard assembly (6) and tighten sling to reduce load bearing on the anchorboard assembly (6).
5. Remove toggle pin (7) securing anchorboard assembly (6) to stanchion (8).
6. Remove toggle pin (9) securing stanchion to deck (10).
7. Remove the stanchion (8).
8. Remove three locking pins (11) from anchorboard assembly weldment (12).

WARNING



HEAVY PARTS

The anchorboard weighs approximately 3500 pounds. Use proper hoisting and lifting equipment to prevent possible injury to personnel or damage to equipment.

9. Using crane and appropriate sling, remove the anchorboard assembly (6) from the deck (10).
10. Remove slings and shackles.

END OF WORK PACKAGE

**OPERATOR MAINTENANCE
CAUSEWAY FERRY
MAIN MAST DECK FLOODLIGHTS
OPERATION UNDER USUAL CONDITIONS**

INITIAL SETUP:**Tools**

Tool Kit, General Mechanic's (Rail and Marine) (Item 76, WP 0105 00)
 Gloves, Men's and Women's (Leather Palm) (Item 31, WP 0105 00)
 Goggles, Sun, Wind and Dust (Safety) (Item 34, WP 0105 00)
 Life Preserver, Vest (Item 45, WP 0105 00)
 Helmet, Safety (Brown) (Item 40, WP 0105 00)

Personnel Required

Seaman 88K

PREPARATION FOR MOVEMENT - REMOVAL OF CAUSEWAY FERRY MAIN MAST DECK FLOODLIGHTS

REMOVE MAIN MAST DECK FLOODLIGHTS**NOTE**

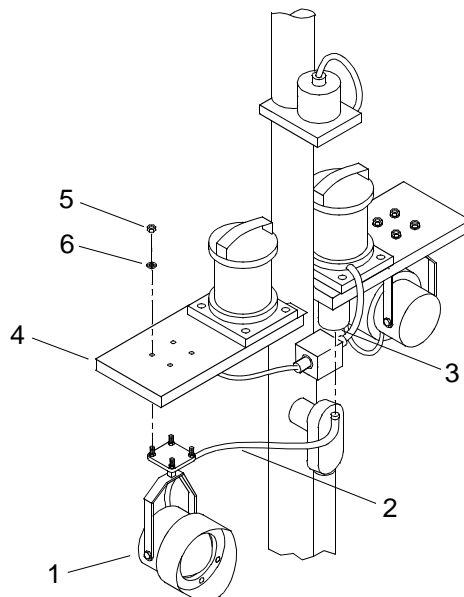
This task is typical for removal of both port and starboard deck floodlights

1. Gain access to the top of the operators cab using steps on side of operators cab.

WARNING

**HEAVY OBJECTS**

2. Disconnect main mast deck floodlight (1) electrical wire (2) from junction box (3).



3. Remove main mast deck floodlight (1) from main mast mounting bracket (4).
 - a. Remove four nuts (5) and washers (6) from main mast deck floodlight (1).
 - b. Remove main mast deck floodlight (1) and stow in BII container.

END OF WORK PACKAGE

**OPERATOR MAINTENANCE
CAUSEWAY FERRY
ABOVE DECK EQUIPMENT
OPERATION UNDER USUAL CONDITIONS**

INITIAL SETUP:**Tools**

Tool Kit, General Mechanic's (Rail and Marine) (Item 76, WP 0105 00)
Gloves, Men's and Women's (Leather Palm) (Item 31, WP 0105 00)
Goggles, Sun, Wind and Dust (Safety) (Item 34, WP 0105 00)
Life Preserver, Vest (Item 45, WP 0105 00)
Helmet, Safety (Brown) (Item 40, WP 0105 00)
Gloves, Chemical (Item 29, WP 0105 00)
Goggles, Industrial (Chipping, Chemical) (Item 32, WP 0105 00)
Sling, 5,300 lb (Green) (Item 69, WP 0105 00)
Qty 2
4 ¾ Ton ¾ in. Shackle (Item 5, WP 0105 00)
Qty 2

Materials/Parts

Adhesive (Item 1, WP 0106 00)
Shoring Block (Item 21, (WP 0106 00)

Personnel Required

Seaman 88K (2)

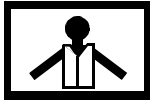
Equipment Condition

Remove Deck Box. (WP 0035 10)
Remove Crew Shelter. (WP 0035 20)
Safety Equipment Removed. (WP 0036 00)
Fenders Removed. (WP 0037 00)
D-Ring/Cloverleaf And Deck Cleat Fittings Removed. (WP 0038 00)
Stub Navigation Mast Removed. (WP 0039 00)
Main Mast Deck Floodlights Removed. (WP 0040 10)

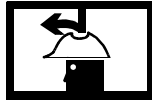
**PREPARATION FOR MOVEMENT - REMOVAL OF CAUSEWAY FERRY
ABOVE DECK EQUIPMENT**

LOWER MAIN MAST

WARNING



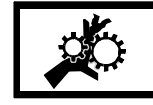
VEST



HELMET PROTECTION



HEAVY PARTS



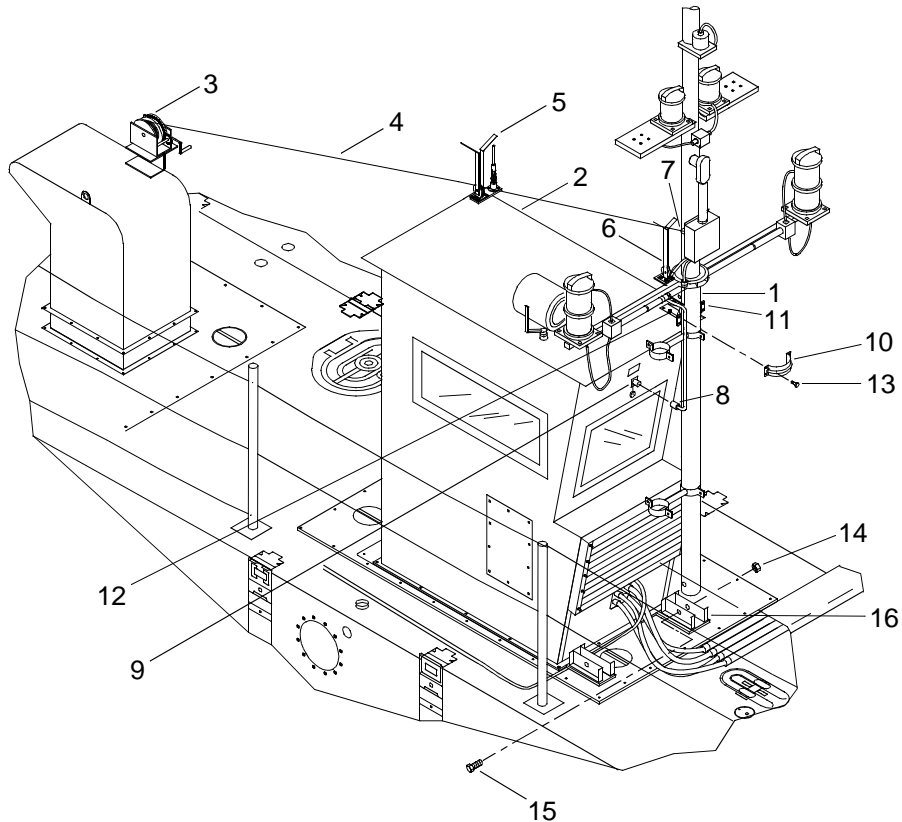
MOVING PARTS

All personnel must wear a personal flotation device, hard hat, safety shoes and gloves during CF operations and maintenance. Failure to observe these precautions could result in serious injury or death to personnel.

NOTE

All shipping hardware is retained in the shipping rack.

1. Using an assistant, lower main mast assembly (1).



- a. Gain access to top of operators cab (2) using steps on side of cab.

WARNING

Failure to maintain control of the winch handle during operation of the winch may result in serious injury and or death to personnel.

NOTE

It may be necessary to turn the handle on the winch slightly (pull wire rope in) in order to disengage the ratcheting device.

- b. Place mast winch (3) in neutral or reverse position.
- c. As assistant lets winch cable (4) out of mast winch (3), guide winch cable (4) through rear sheave (5) and forward sheave (6).
- d. Connect winch cable (4) to padeye (7) on main mast assembly (1).
- e. Disconnect mast electrical connector (8) from operators cab connector (9).
- f. Remove outer clamp half (10) from operator cab clamp half (11).
 - {1} Remove nuts (12) from bolts (13).
 - {2} Remove bolts (13) from clamp halves (10 and 11).
 - {3} Remove outer clamp half (10).
- g. Descend from top of operators cab (2) using steps on side of cab.
- h. Loosen nut (14) and bolt (15) on deck holder (16) to allow the main mast assembly (1) to be lowered to deck.

WARNING

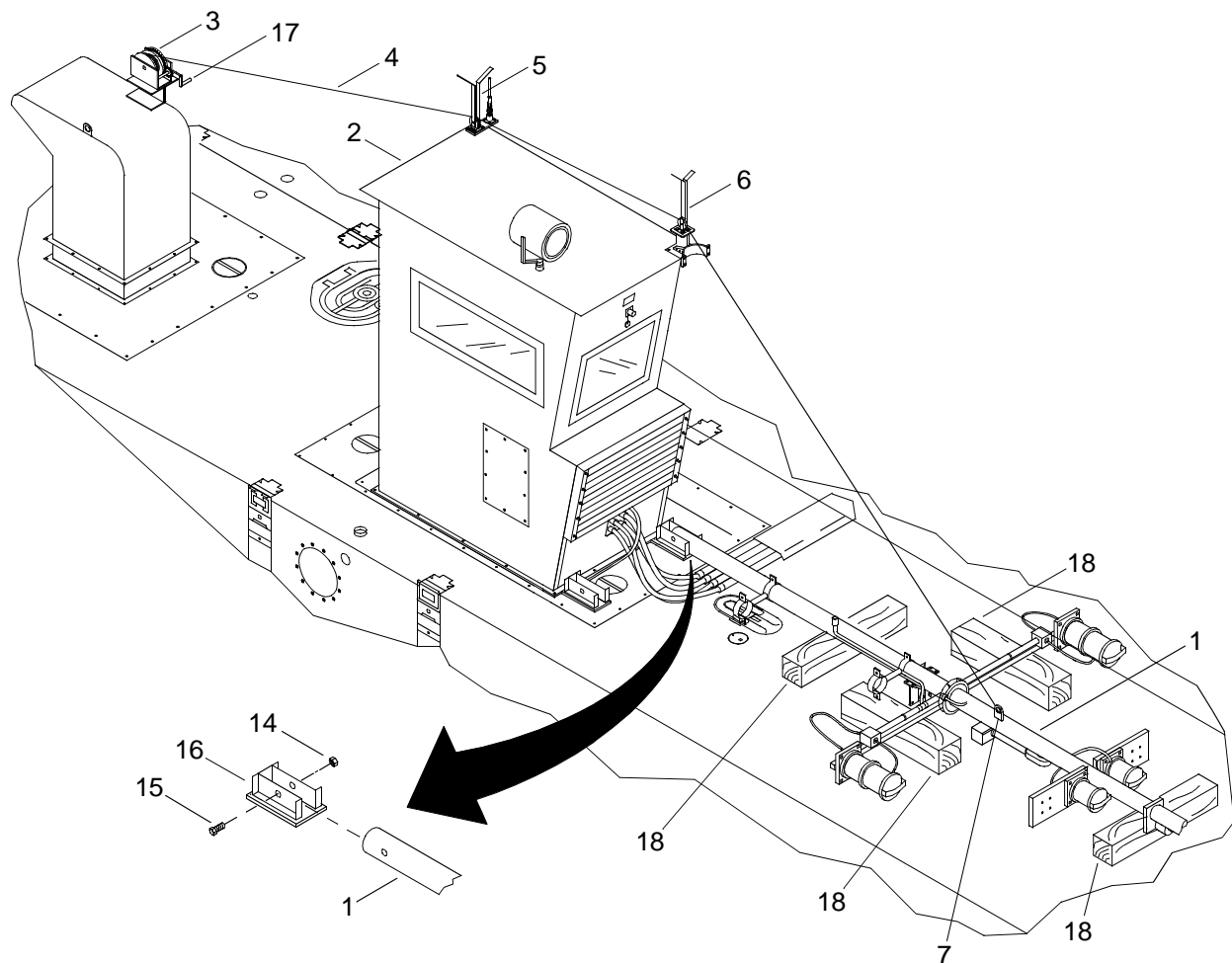
**HEAVY PARTS****MOVING PARTS**

Before lowering the main mast, the ratchet must snap into engagement. Failure to comply could result in serious injury to personnel and/or damage to equipment.

NOTE

Prior to operating the main mast winch, read the cable in/cable out decal located on the winch housing.

- i. Using main mast winch (3), lower the main mast assembly (1).



{1} Place the mast winch ratchet in the hold position.

WARNING



MOVING PARTS

- {2} Turn crank handle (17) counterclockwise to lower main mast assembly (1).
- j. Place a wooden shoring block (18) on the deck at end of the main mast assembly (1) and finish lowering until the main mast assembly (1) is resting on the wooden shoring block (18).
 - k. Gain access to top of operators cab (2) using steps on side of cab.
 - l. Install clamp outer half (10) on the operators cab clamp half (11) using four bolts (13) and nuts (12).
 - m. Tighten nuts (12).
2. Turn crank handle (17) counterclockwise to remove tension from winch cable (4).
 3. Remove winch cable (4) from main mast padeye (7).

4. Turn crank handle (17) clockwise and coil winch cable (4) back onto mast winch (3) while guiding winch cable (4) through forward and aft sheaves (6, 5).
5. Descend from operators cab (2).

REMOVE MAIN NAVIGATION MAST ASSEMBLY

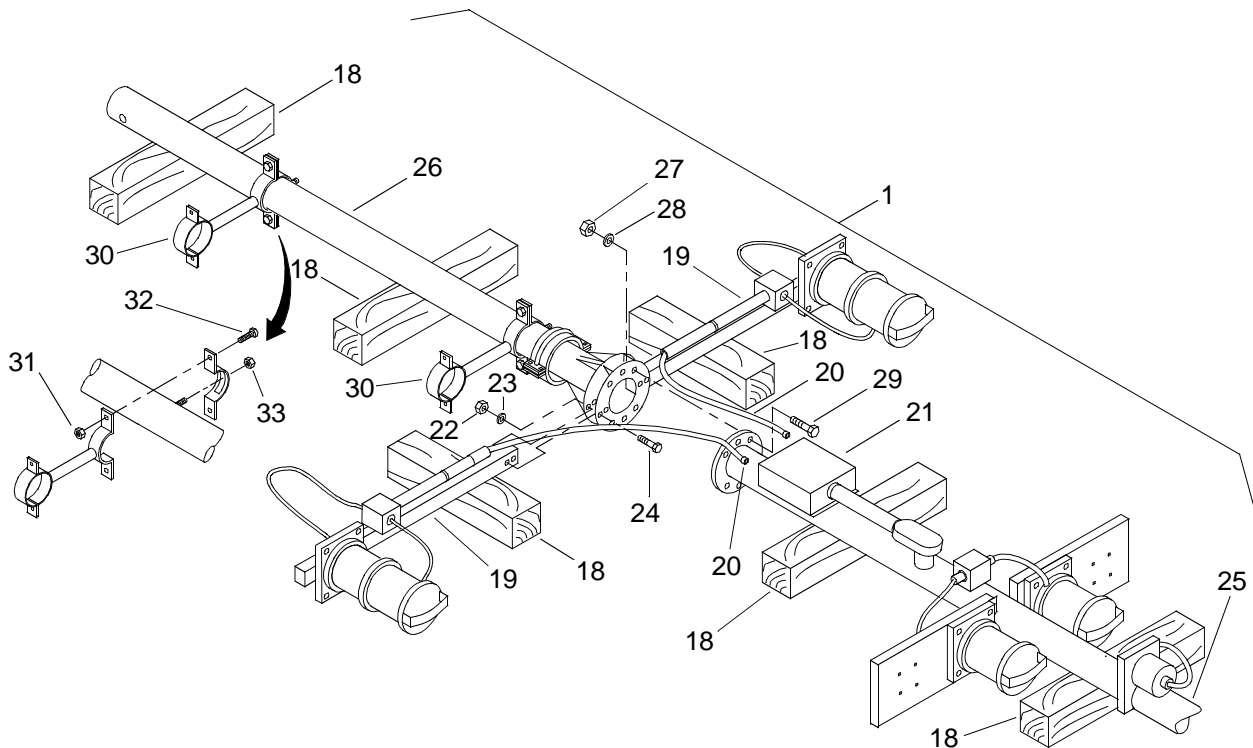
1. Install sling and shackle to support the main mast assembly (1).
2. Remove nut (14).
3. Remove bolt (15) from main mast assembly (1) and deck holder (16).

WARNING



HEAVY PARTS

4. Using sling, shackle and crane, raise the main mast assembly (1) to remove from deck holder (16) and place onto wooden shoring blocks (18).
5. Disassemble main mast assembly (1).



NOTE

This step is typical for both port and starboard yardarms.

- a. Remove lower mast yardarm (19).

{1} Disconnect yardarm electrical cable connectors (20) from mast junction box (21).

{2} Remove two nuts (22), washers (23) and bolts (24) from yardarm (19).

WARNING



HEAVY PARTS

{3} Remove yardarm (19) and place on wooden shoring blocks (18).

WARNING



HEAVY PARTS

b. Remove upper mast (25) from lower mast (26).

{1} Remove six nuts (27) and washers (28) from bolts (29).

{2} Remove bolts (29).

{3} Remove upper mast (25) from lower mast (26).

c. Rotate stub mast mounts (30) on lower main mast (26).

{1} Loosen nuts (31) and bolts (32).

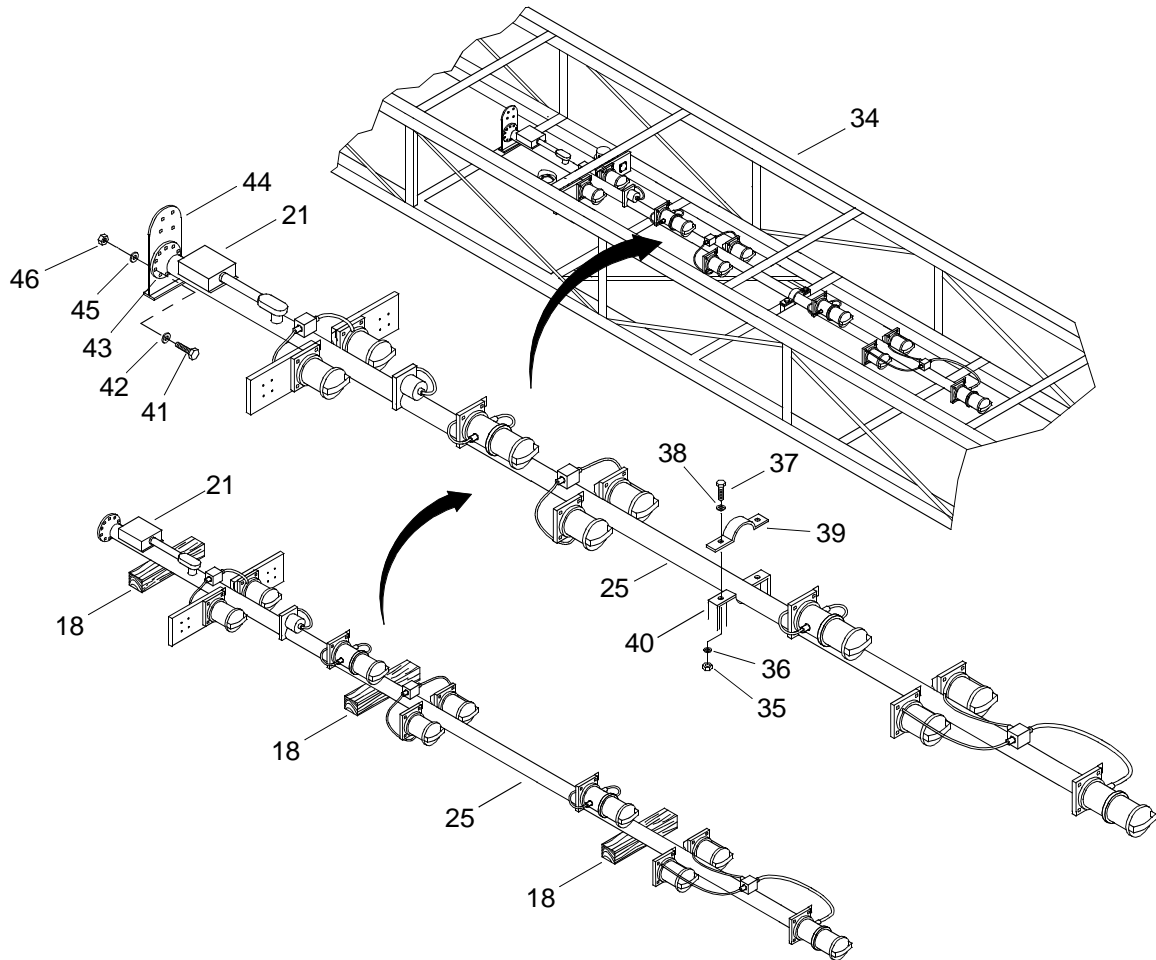
{2} Loosen nuts (33) on stub mast mounts (30).

{3} Rotate stub mast mounts (30) 90° clockwise.

{4} Tighten nuts (31) and bolts (32).

{5} Tighten nuts (33).

6. Install upper mast (25) in shipping rack (34).



- a. Remove two nuts (35), washers (36), bolts (37) and washers (38) securing upper clamp half (39) to shipping rack bracket (40).
- b. Remove upper clamp half (39) from shipping frame bracket (40).

WARNING



HEAVY PARTS

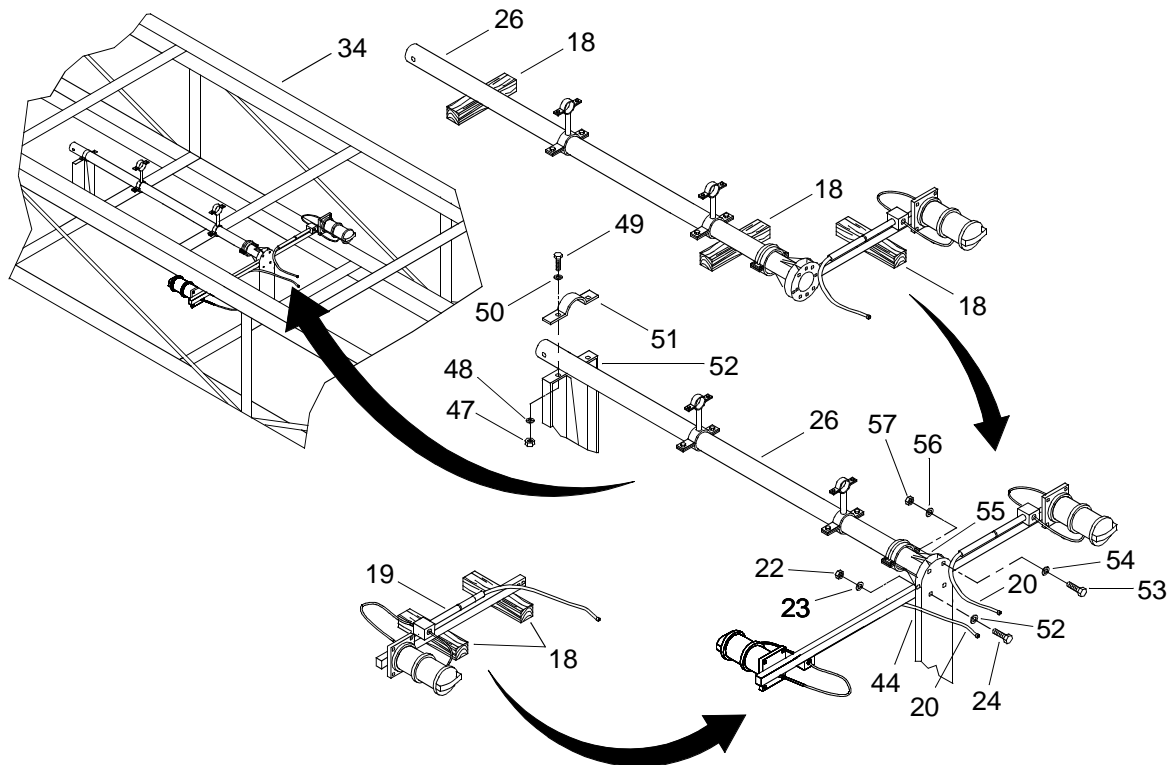
- c. Using crane, sling and shackle, lift upper mast (25) from deck and place into shipping frame (34).
 - {1} Install four bolts (41) and washers (42) through upper mast weldment (43) and shipping rack bracket (44).
 - {2} Install four washers (45) and nuts (46) on bolts (41).
 - {3} Tighten nuts (46).
 - {4} Install upper clamp half (39) over shipping rack bracket (40).

{5} Install two bolts (37) with washers (38), two washers (36) and two nuts (35) to secure upper clamp half (39) to shipping rack bracket (40).

{6} Tighten nuts (35).

{7} Remove sling and shackle.

7. Install lower mast (26) in shipping rack (34).



- a. Remove two nuts (47), washers (48), bolts (49) and washers (50) securing upper clamp half (51) to shipping rack bracket (52).
- b. Remove upper clamp half (51) from shipping rack bracket (52).

WARNING



HEAVY PARTS

- c. Using crane, slings and shackles, lift lower mast (26) from deck and place into shipping rack (34).

{1} Install four bolts (53), with washers (54) through lower mast weldment (55) and shipping rack bracket (44).

{2} Install four washers (56) and nuts (57) on bolts (53).

{3} Tighten nuts (57).

-
- {4} Remove slings and shackles.
 - {5} Install upper clamp half (51) on shipping rack bracket (52).
 - {6} Install two bolts (49) with washers (50), two washers (48) and two nuts (47) to secure upper clamp half (51) to shipping rack bracket (52).
 - {7} Tighten nuts (47).

WARNING



HEAVY PARTS

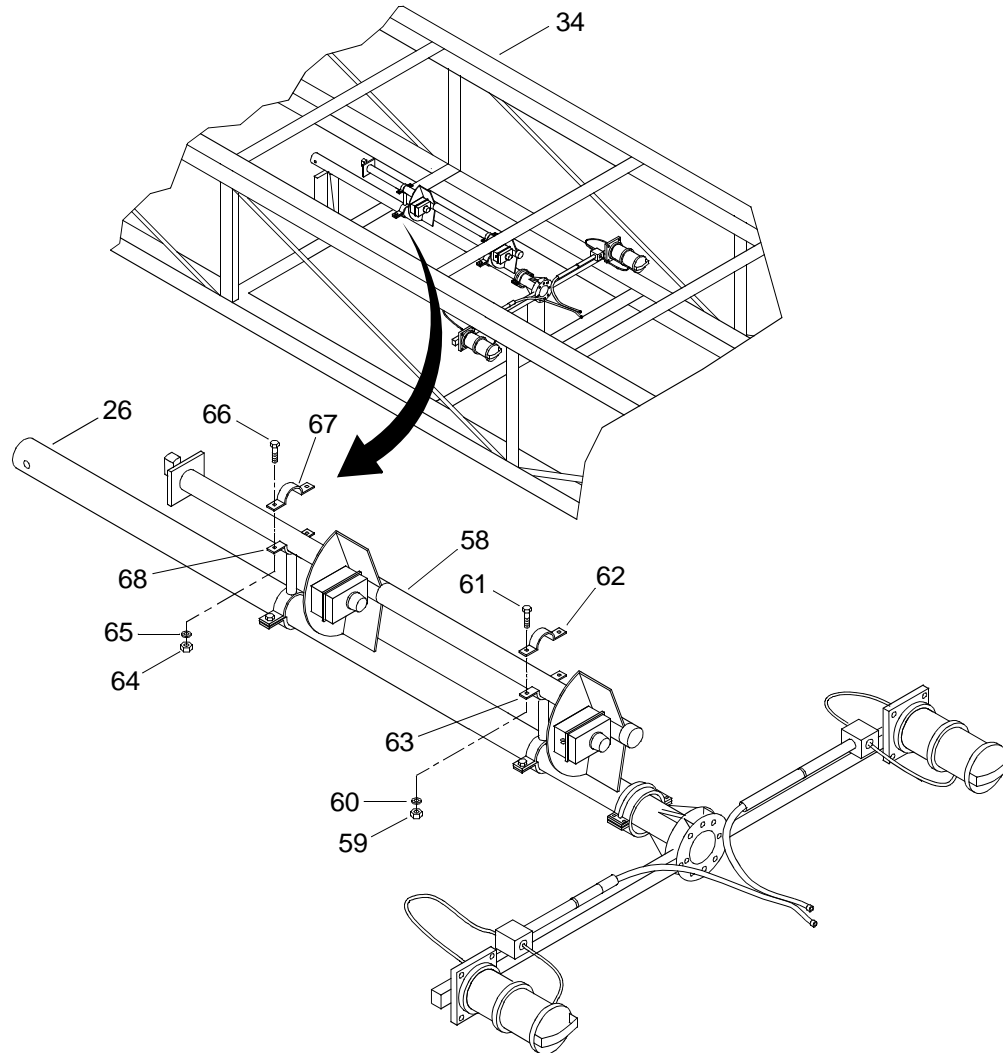
NOTE

This step is typical for both port and starboard yardarms, except port yardarm must be installed facing toward bottom of lower mast.

- d. Install lower mast yardarm (19).
 - {1} Align holes in yardarm (19) with holes in lower mast weldment (55).
 - {2} Install two bolts (24) and washers (54) into lower mast weldment (55) and yardarm (19).
 - {3} Install two washers (23) and nuts (22) on bolts (24).
 - {4} Tighten nuts (22).
- e. Connect yardarm electrical cable connector (20) to mast junction box (21).

STOW STUB MAST

1. Using an assistant, position stub mast (58) in shipping frame (34).



- a. Remove two nuts (59), washers (60) and bolts (61) from clamp halves (62 and 63) on lower main mast (26).
- b. Remove two nuts (64), washers (65) and bolts (66) from clamp halves (67 and 68) on lower main mast (26).
- c. Remove clamp halves (62 and 67).

WARNING

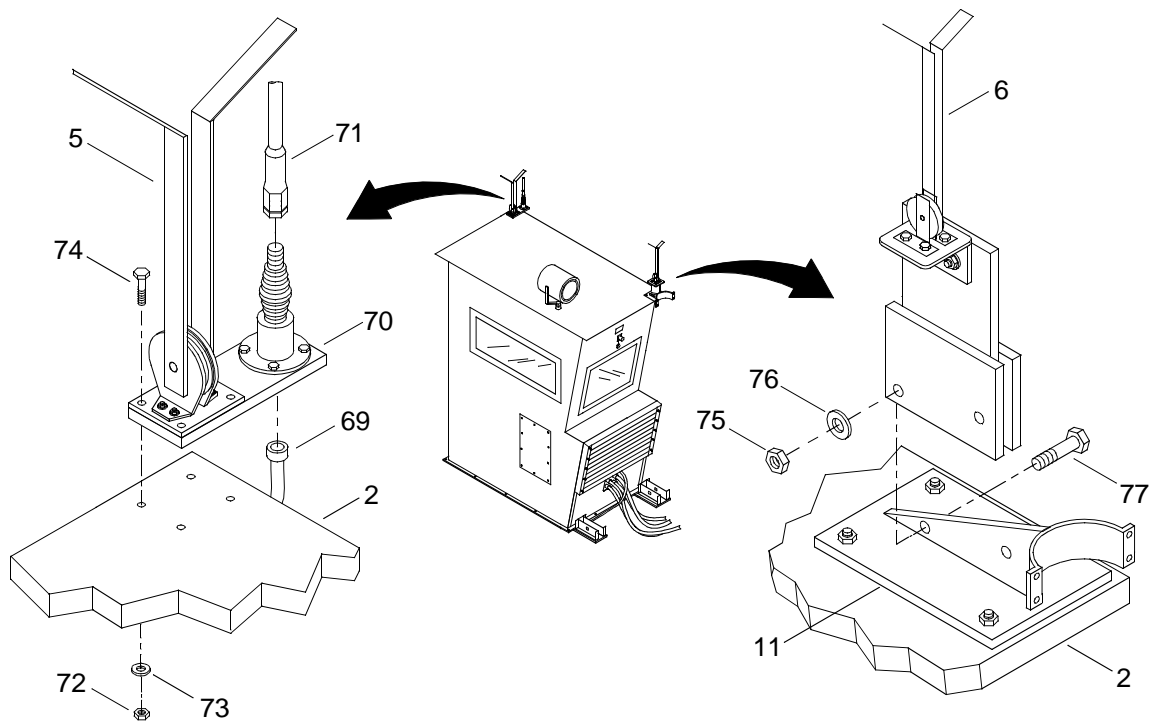
**HEAVY OBJECTS**

- d. Position stub mast (58) on lower main mast (26) in shipping frame (34).
- e. Install clamp half (62) over upper end of stub mast (58) on clamp half (63).

- {1} Align removable clamp half (62) holes with clamp half (63) holes.
 - {2} Install two bolts (61), washers (60) and nuts (59).
 - {3} Tighten nuts (59).
- f. Install clamp half (67) over lower end of stub mast (58) on clamp half (68) on lower main mast (26).
- {1} Align removable clamp half (67) holes with clamp half (68) holes.
 - {2} Install two bolts (66), washers (65) and nuts (64).
 - {3} Tighten nuts (64).

REMOVE WIRE ROPE SHEAVES AND SINGGAR ANTENNA

1. Gain access to top of operators cab (2) using steps on side of cab.

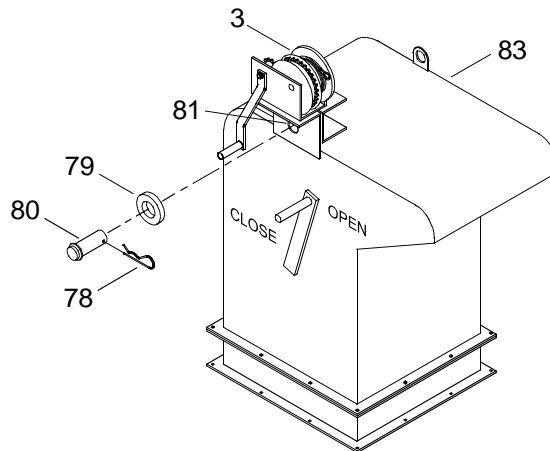


2. Disconnect SINGGARS antenna cable connector (69) to bottom of SINGGARS antenna mount (70).
3. Remove SINGGARS antenna (71) from spring base of SINGGARS antenna mount (70).
4. Remove nuts (72), washers (73) and bolts (74) securing combination rear sheave (5) and SINGGARS antenna mount (70) on rear of cab (2) roof.
5. Remove combination rear sheave (5) and SINGGARS antenna mount (70) from rear of cab (2) roof.
6. Install bolts (74), washers (73) and nuts (72) on combination rear sheave (5) and SINGGARS antenna mount (70). Tighten nuts (72).
7. Remove nuts (75), washers (76) and bolts (77) securing front sheave (6) with mount to cab mast clamp mount (11).

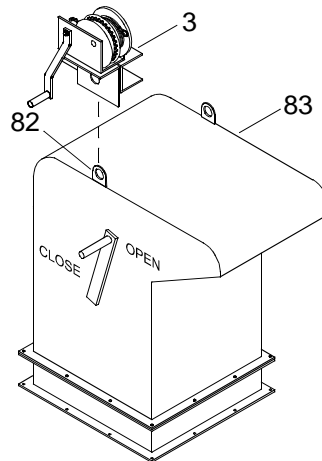
8. Remove front sheave (6) with mount from cab mast clamp mount (11).
9. Install bolts (77), washers (76) and nuts (75) on front sheave (6) with mount. Tighten nuts (75).
10. Stow SINCGARS antenna (71), front sheave (6) with mount and combination rear sheave (5) and SINCGARS antenna mount (70) inside operators cab (2).

REMOVE MAIN MAST WINCH ASSEMBLY

1. Remove clevis pin (78) and large washer (79) from pipe assembly (80).



2. Remove pipe assembly (80) winch mounting hole (81).
3. Remove mast winch (3) from inboard lifting shackle (82) of exhaust plenum (83).



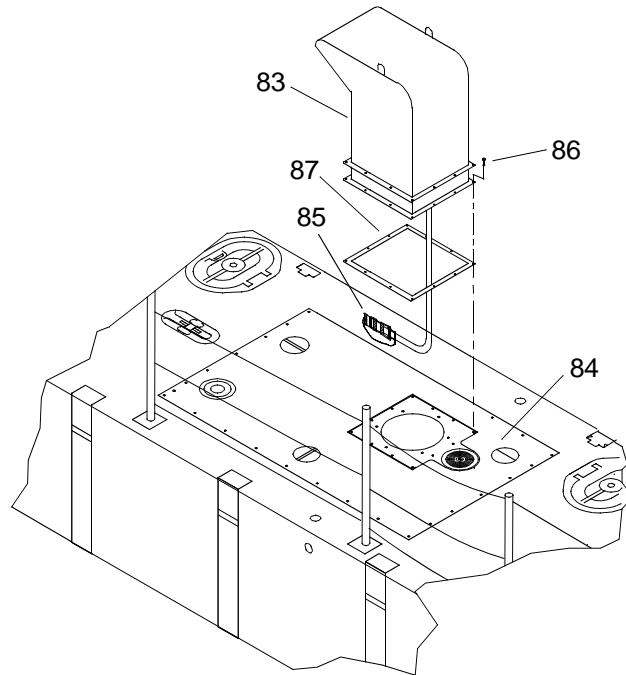
4. Stow mast winch (3) in BII container.

REMOVE PORT AND STARBOARD PROPULSION MODULE EXHAUST PLENUMS

NOTE

The following procedure is typical for both port and starboard propulsion module exhaust plenums.

1. Remove propulsion module exhaust plenum (83) from pump-jet thruster hatch (84).



- a. Disconnect propulsion module exhaust plenum fan cable (85) from vent fan relay panel A8.
- b. Secure propulsion module exhaust plenum fan cable (85) inside of propulsion module exhaust plenum (83).
- c. Remove 12 bolts (86) attaching propulsion module exhaust plenum (83) to pump-jet thruster hatch (84).

WARNING

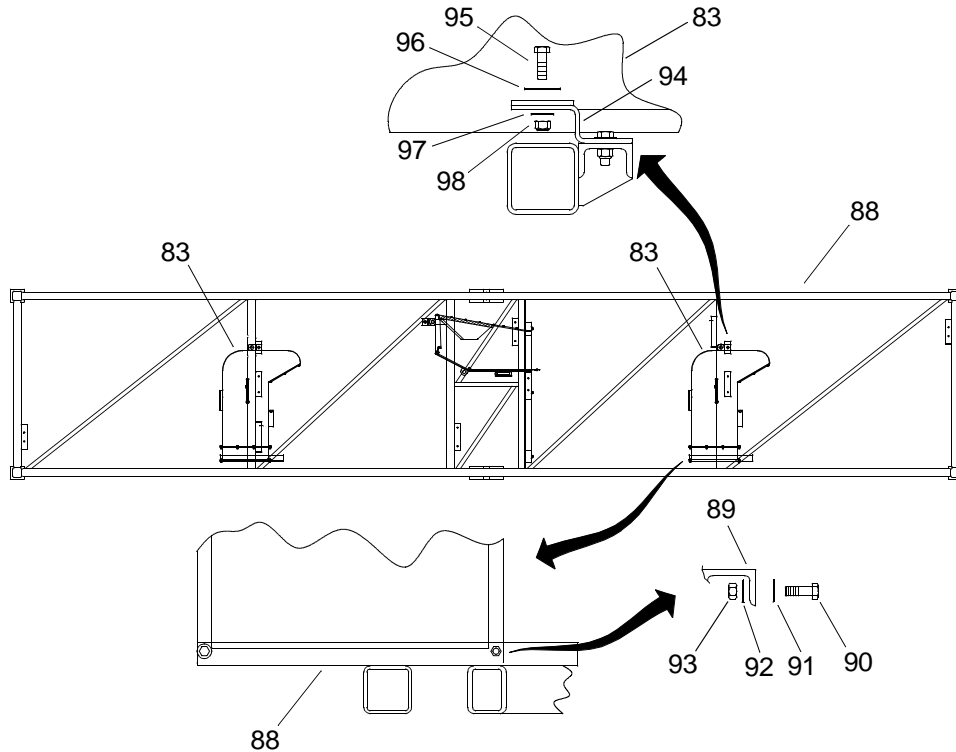
**HEAVY PARTS**

- d. Using crane, slings and shackles, lift propulsion module exhaust plenum (83) from pump-jet thruster hatch (84).
- e. Remove plenum gasket (87), if attached to exhaust plenum.

WARNING

**HEAVY PARTS**

2. Stow propulsion module exhaust plenum (83) in shipping rack (88).

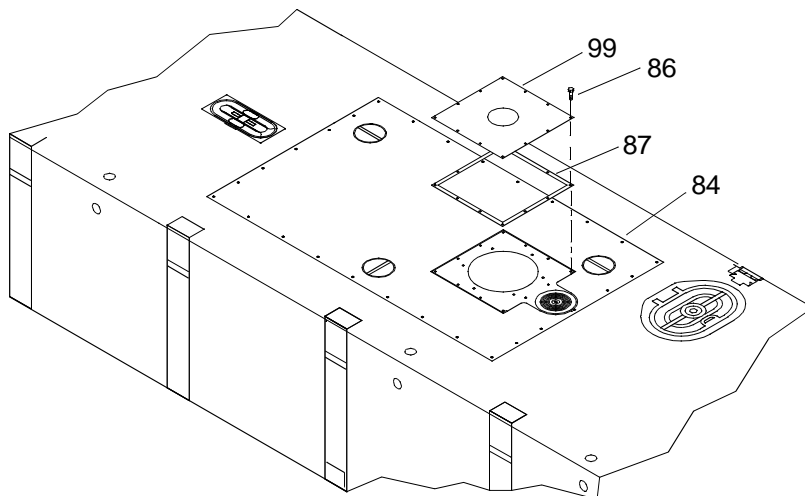


- Align holes in base of propulsion module exhaust plenum (83) with holes in shipping rack bracket (89).
- Install two bolts (90) and washers (91) through base of propulsion module exhaust plenum (83) and shipping rack bracket (89).
- Install four washers (92) and two nuts (93) on bolts (90).
- Align hole in top of propulsion module exhaust plenum (83) with hole in shipping rack bracket (94).
- Install bolt (95) and fender washer (96) through top of plenum (83) and shipping rack bracket (94).
- Install washer (97) and nut (98) on bolt (95).
- Tighten nuts (93 and 98).
- Remove slings and shackles.

WARNING

**HEAVY PARTS**

3. Install shipping plate (99) on propulsion module pump-jet thruster hatch (84).



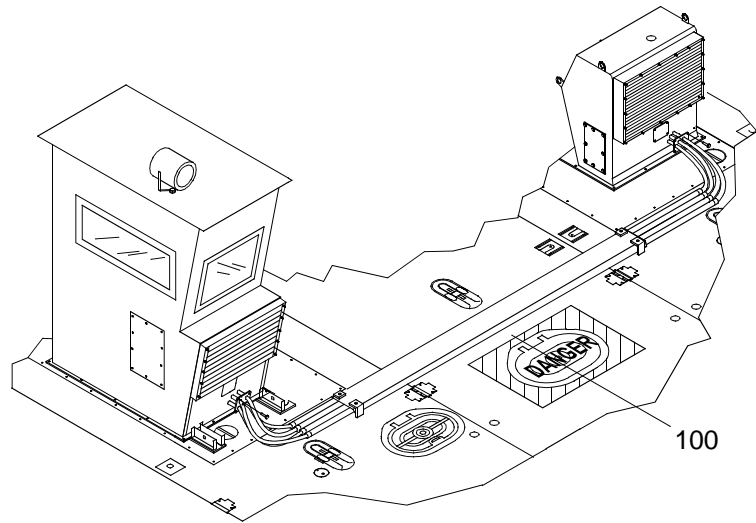
- a. Install gasket (87), if necessary.
- b. Align holes in shipping plate (99) with holes in pump-jet thruster hatch (84).
- c. Install 12 bolts (86) to secure shipping plate (99) to propulsion module pump-jet thruster hatch (84).

REMOVE MODULE ELECTRICAL INTERCONNECT ASSEMBLY

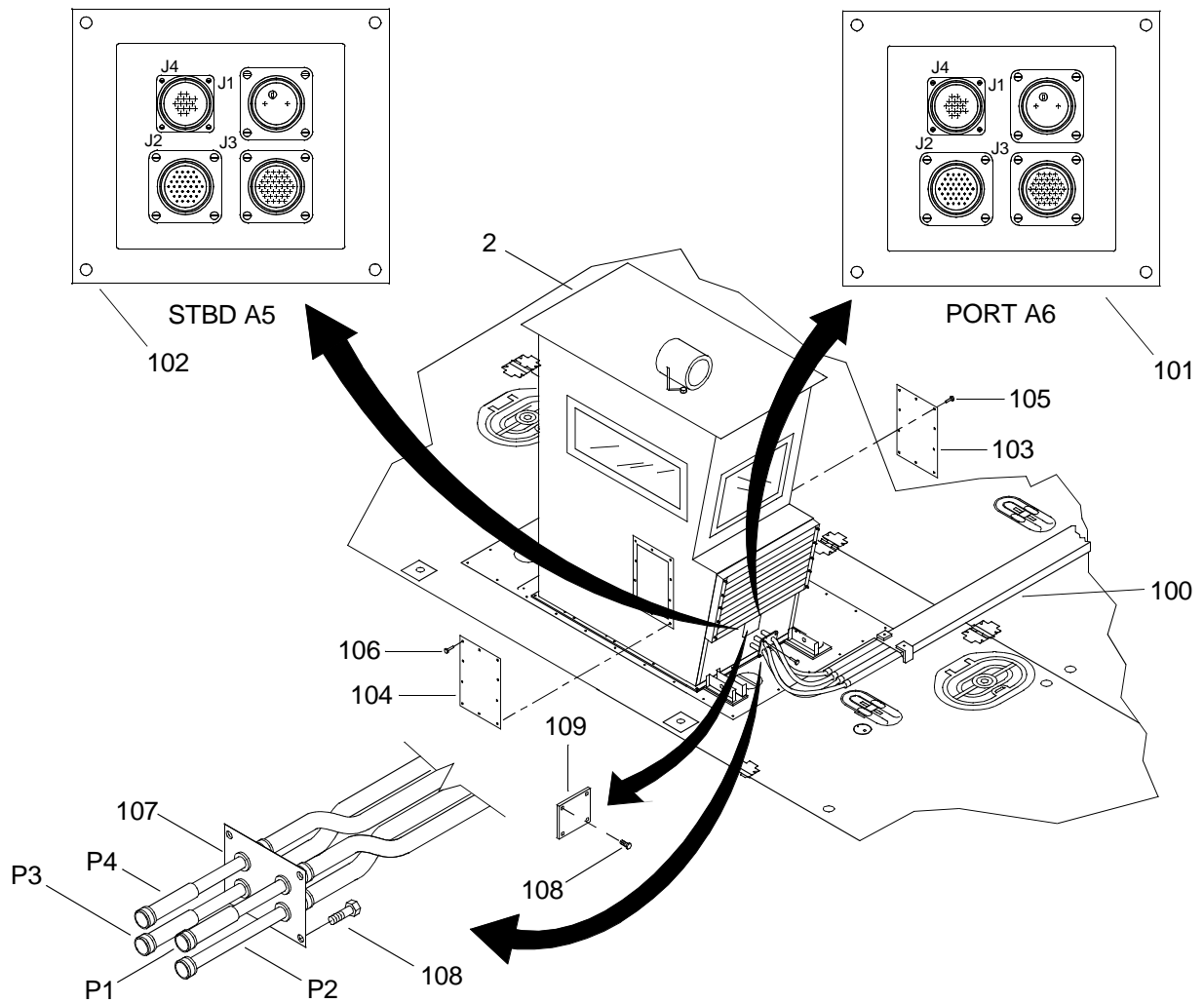
WARNING

**HEAVY PARTS**

1. Remove electrical interconnect assembly (100) from the CF.



- a. Disconnect interconnect cables (100) and propulsion module cables from operators cab receptacles (101 and 102).



-
- {1} Remove operators cab port and starboard side access panels (103 and 104).
- (a) Remove screws (105 and 106) securing side access panels (103 and 104) to operators cab (2).
 - (b) Remove side access panels (103 and 104).
- {2} Disconnect interconnect cables (100) from operators cab PORT receptacle A6 (101).
- (a) Disconnect P2 from PORT A6, J2.
 - (b) Disconnect P4 from PORT A6, J4.
 - (c) Disconnect P3 from PORT A6, J3.
 - (d) Disconnect P1 from PORT A6, J1.
- {3} Disconnect the power module cables from STBD receptacle A5 (102).
- (a) Disconnect power module A6, P2 from STBD A5, J2.
 - (b) Disconnect power module A6, P4 from STBD A5, J4.
 - (c) Disconnect power module A6, P3 from STBD A5, J3.
 - (d) Disconnect power module A6, P1 from STBD A5, J1.
- {4} Remove conduit entry plate (107) from front of operators cab (2).
- (a) Remove four screws (108) securing conduit entry plate (107) to operators cab (2).
 - (b) Remove conduit entry plate (107).
- {5} Install both operators cab side access panels (103 and 104).
- (a) Align panel (103) holes with holes in operators cab (2).

—————
WARNING
—————



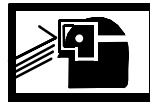
CHEMICAL



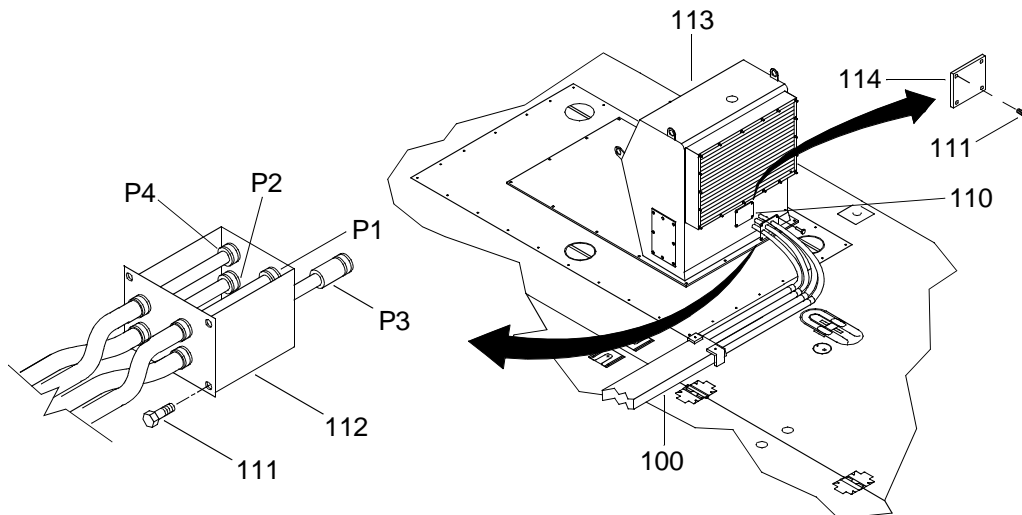
EYE PROTECTION

- (b) Apply adhesive to threads of screws (105).
- (c) Install 10 screws (105) through side access panel (103) into operators cab (2).
- (d) Tighten screws (105).
- (e) Align panel (104) holes with holes in operators cab (2).

WARNING

**CHEMICAL****EYE PROTECTION**

- (f) Apply adhesive to threads of screws (106).
 - (g) Install 10 screws (106) through side access panel (104) into operators cab (2).
 - (h) Tighten screws (106).
- {6} Install operators cab front access panel (109).
- (a) Align holes in access panel (109) with holes in front of operators cab (2).
 - (b) Install screws (108) through front access panel (109) into operators cab (2).
 - (c) Tighten screws (108).
- b. Disconnect interconnect cables (100) from air intake plenum receptacles.



- {1} From below deck, disconnect power module cables from interconnect cable receptacles.
- (a) Disconnect power module junction box A6, P2 from interconnect cable, P2.
 - (b) Disconnect power module junction box A6, P4 from interconnect cable, P4.
 - (c) Disconnect power module junction box A6, P3 from interconnect cable, P3.
 - (d) Disconnect power module A3, P1 from interconnect cable, P1.
- {2} Remove electrical interconnect cables (100) from intake plenum front access (110).
- (a) Remove four bolts (111) securing conduit entry plate (112) to intake plenum (113).

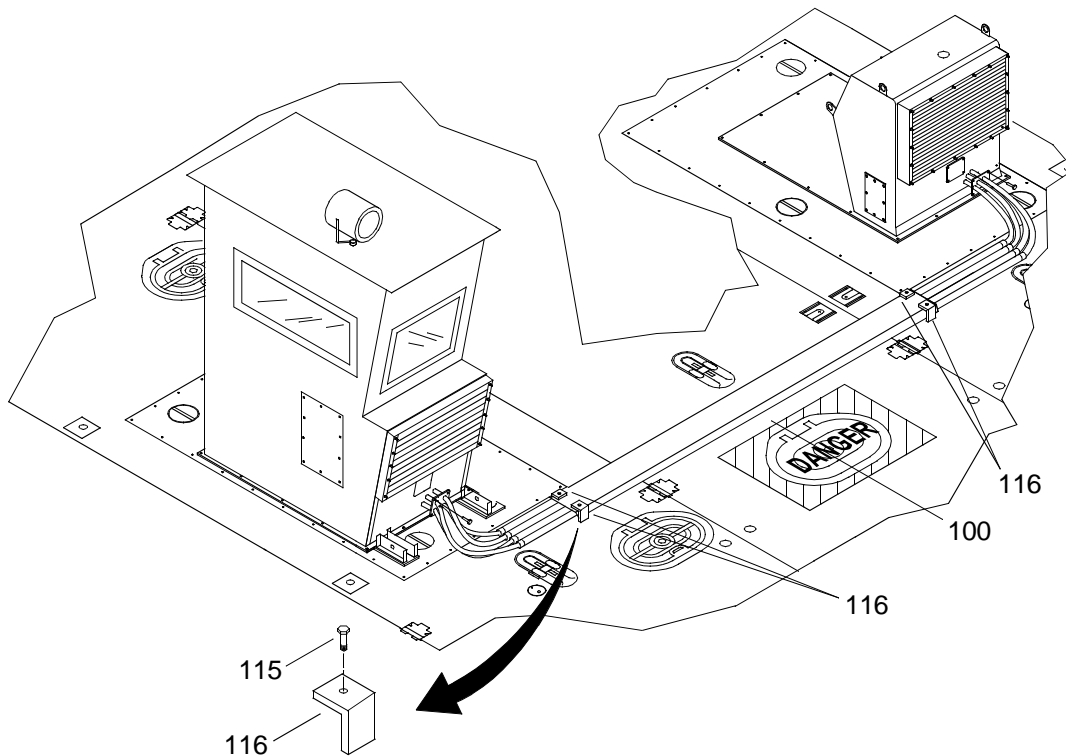
- (b) Remove conduit entry plate (112) from intake plenum (113).
- c. Install intake plenum front access cover (114).
- {1} Align holes in front access cover (114) with holes in intake plenum (113).
- {2} Install screws (111) to secure front access cover (114) to the intake plenum (113).
- {3} Tighten screws (111).

WARNING



HEAVY PARTS

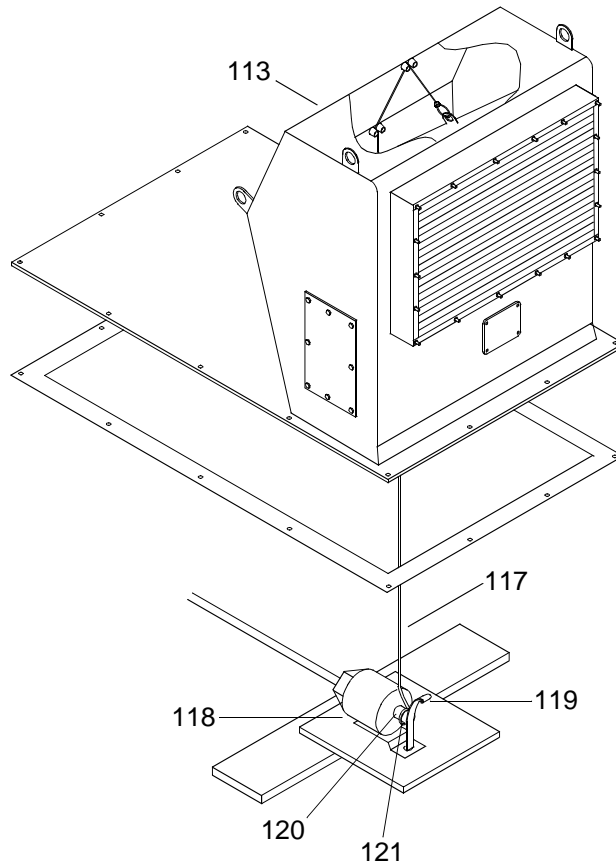
2. Remove electrical interconnect assembly (100) from the CF.



- a. Loosen bolts (115).
- b. Rotate hold down clamps (116) 90° clockwise.
- c. Using crane, slings and shackles, remove electrical interconnect assembly (100).

REMOVE AIR INTAKE PLENUM**WARNING****HEAVY PARTS**

1. Remove intake plenum (113).
 - a. Disconnect wire rope (117) in the intake plenum (113) from the fire suppression trip mechanism (118).

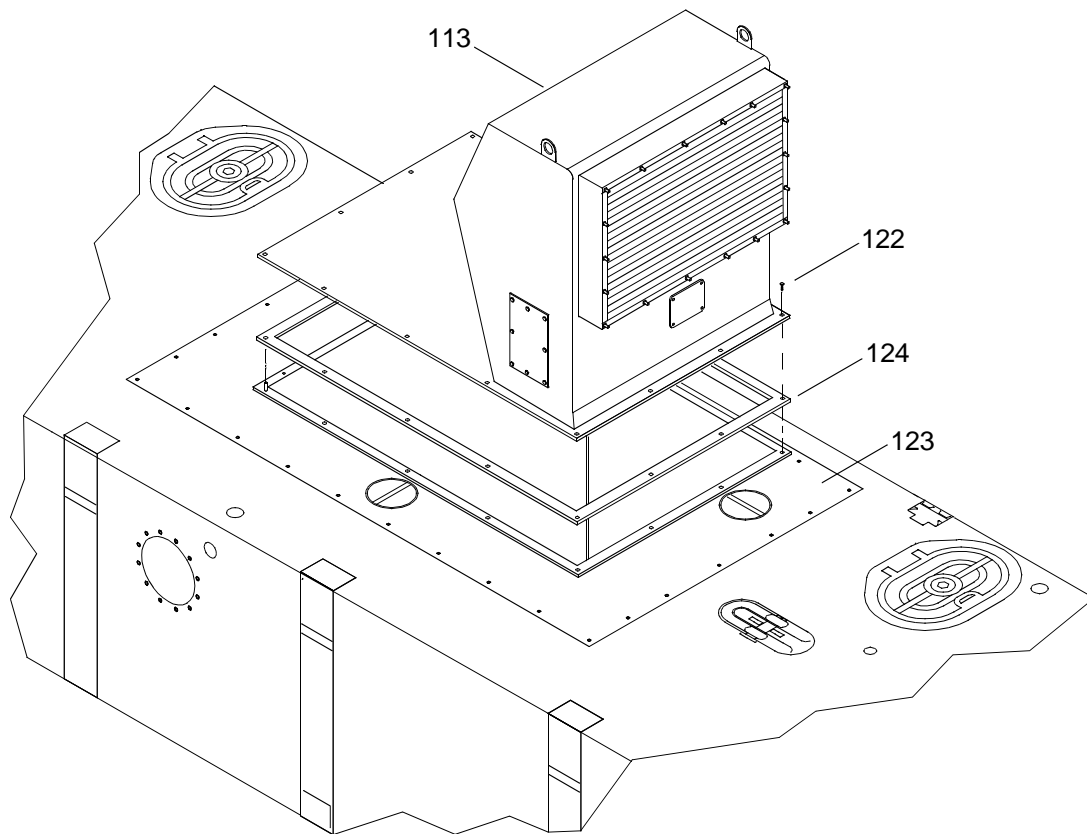


{1} Move fire suppression solenoid spring flange (119) away from solenoid shaft (120).

{2} Remove wire rope ring (121) from the fire suppression solenoid shaft (120).

{3} Release flange (119).

- b. Remove 14 bolts (122) attaching intake plenum (113) to propulsor module hatch (123).

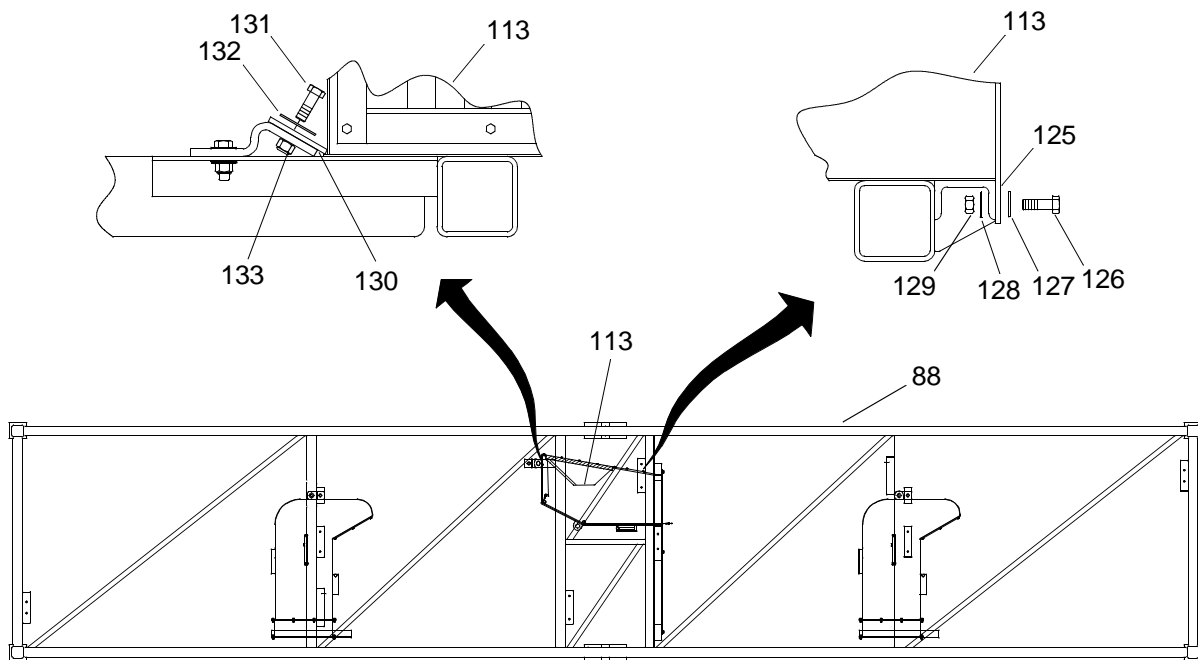


- c. Using crane, slings and shackles, remove air intake plenum (113).
- d. Remove air intake plenum gasket (124), if attached to intake plenum.

WARNING

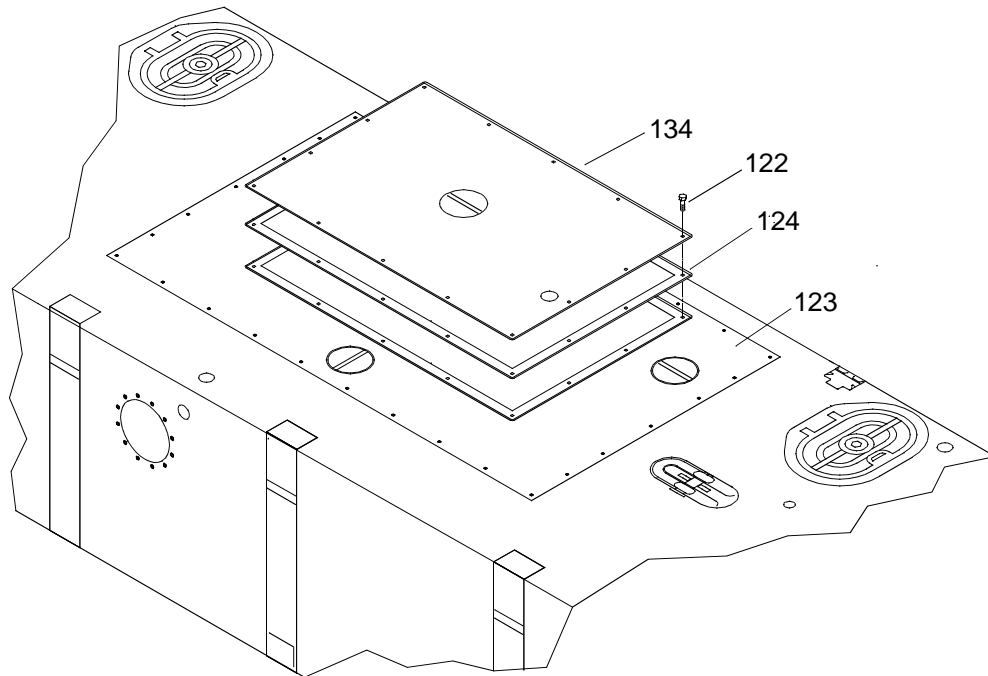
**HEAVY PARTS**

2. Install intake plenum (113) in shipping rack (88).



- a. Align two holes in the base of the intake plenum (113) with holes in shipping rack bracket (125).
- b. Install two bolts (126) and washers (127) through holes in base of intake plenum (113) through shipping rack bracket (125).
- c. Install two washers (128) and nuts (129).
- d. Tighten nuts (129).
- e. Align hole in top of intake plenum (113) with hole in shipping rack bracket (130).
- f. Install bolt (131) and washer (132) through intake plenum (113) and shipping rack bracket (130) into welded nut (133).
- g. Tighten bolt (131).
- h. Remove slings and shackles.

3. Install shipping plate (134) on propulsion module engine hatch (123).



- a. Install gasket (124), if necessary.

WARNING



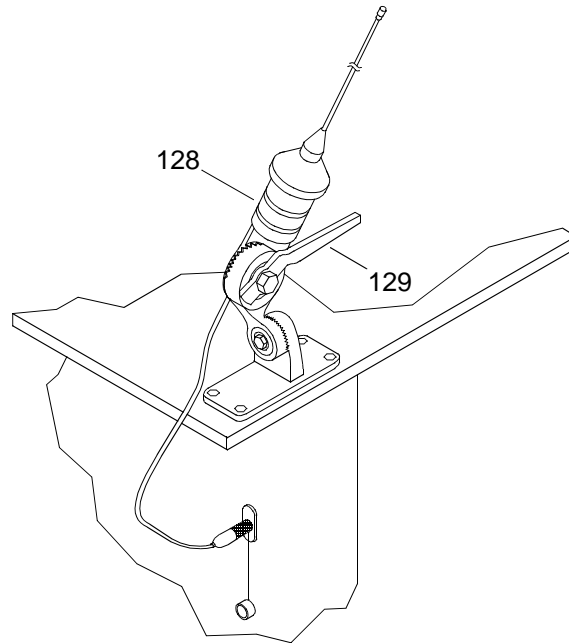
HEAVY PARTS

- b. Using crane, slings and shackles, lower shipping plate (134) onto propulsion module hatch (123).
- c. Install bolts (122) securing shipping plate (134) to hatch (123).
- d. Tighten bolts (122).
- e. Remove slings and shackles.

REMOVE OPERATORS CAB

1. Remove equipment from operators cab (2).
 - a. Gain access to top of operators cab.

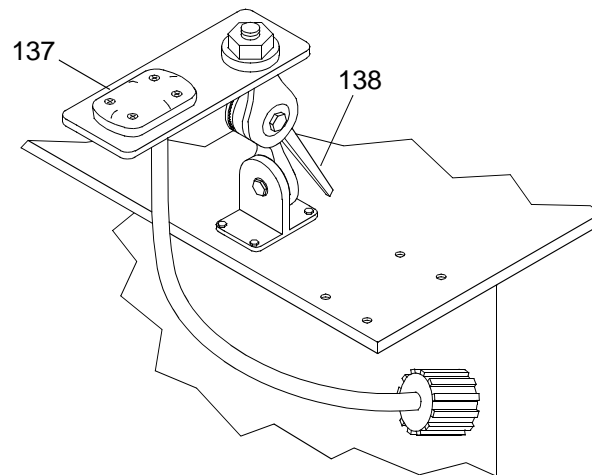
- b. Reposition VHF/FM DSC transceiver antenna (135).



{1} Rotate handle (136) on VHF/FM DSC transceiver antenna ratchet mount counterclockwise to allow rotation of antenna (135) to horizontal position.

{2} Rotate handle (136) on VHF/FM DSC transceiver antenna ratchet mount clockwise to secure antenna (135).

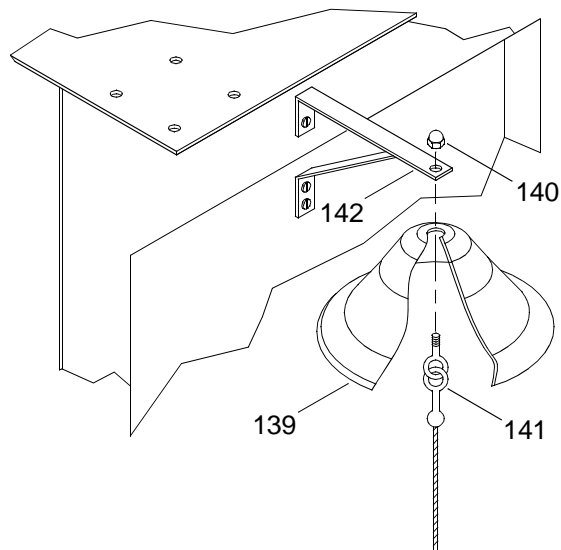
- c. Reposition GPS antenna (137).



{1} Rotate handle (138) on GPS antenna ratchet mount counterclockwise to allow rotation of antenna mount plate downward to operators cab (2) roof.

{2} Rotate handle (138) on GPS antenna ratchet mount clockwise to secure antenna mount plate.

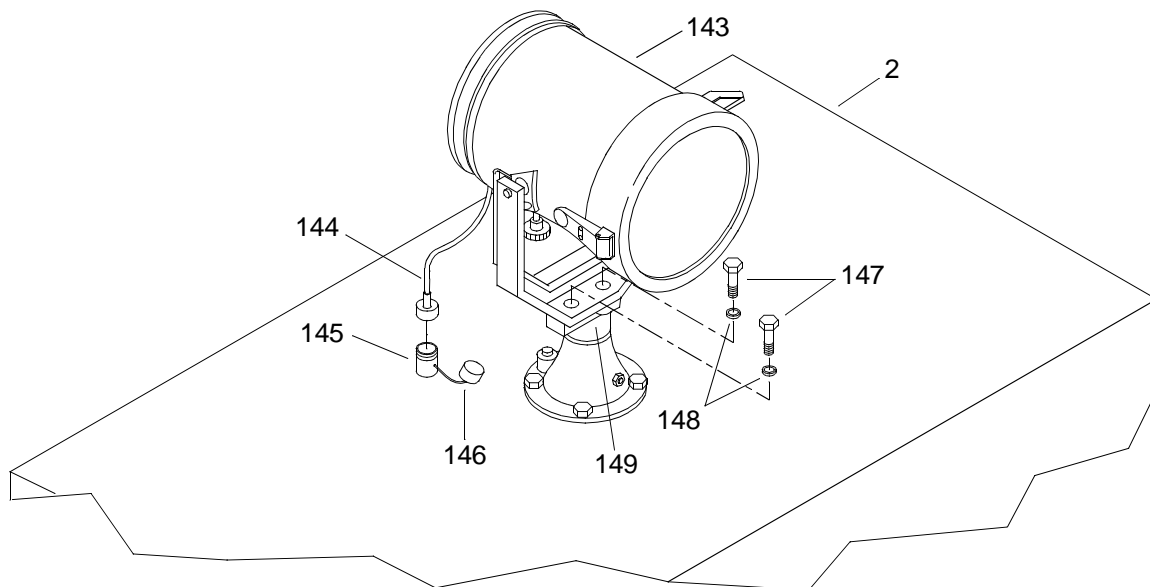
- d. Remove navigation bell (139).



{1} Remove acorn nut (140).

{2} Remove eyebolt clapper assembly (141) and bell (139) from mount (142).

- e. Remove operators cab spotlight (143).



{1} Remove spotlight electrical connector (144) from receptacle (145) on roof of operators cab (2).

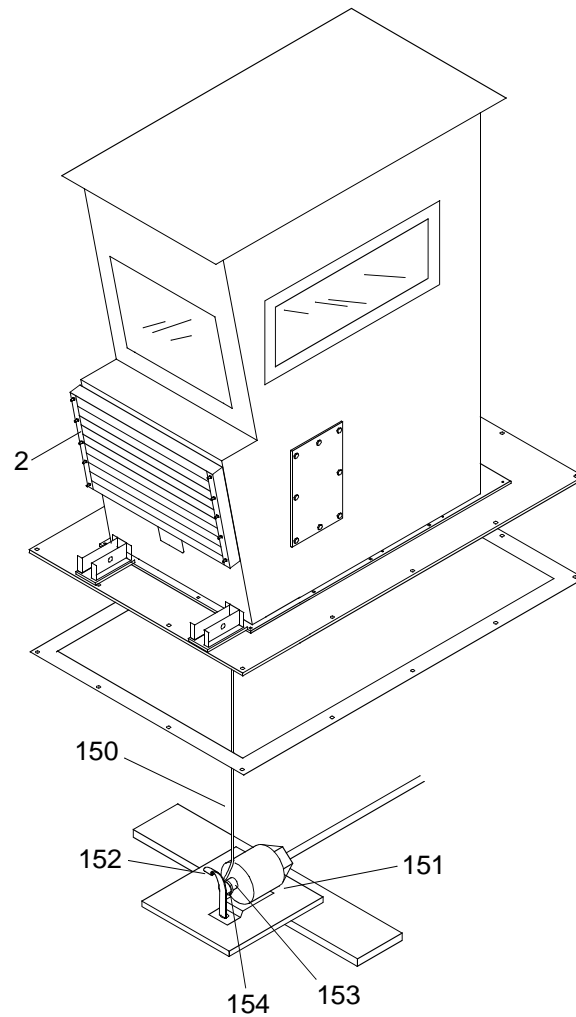
{2} Install spotlight electrical receptacle dust cap (146).

{3} Remove two bolts (147) and washers (148).

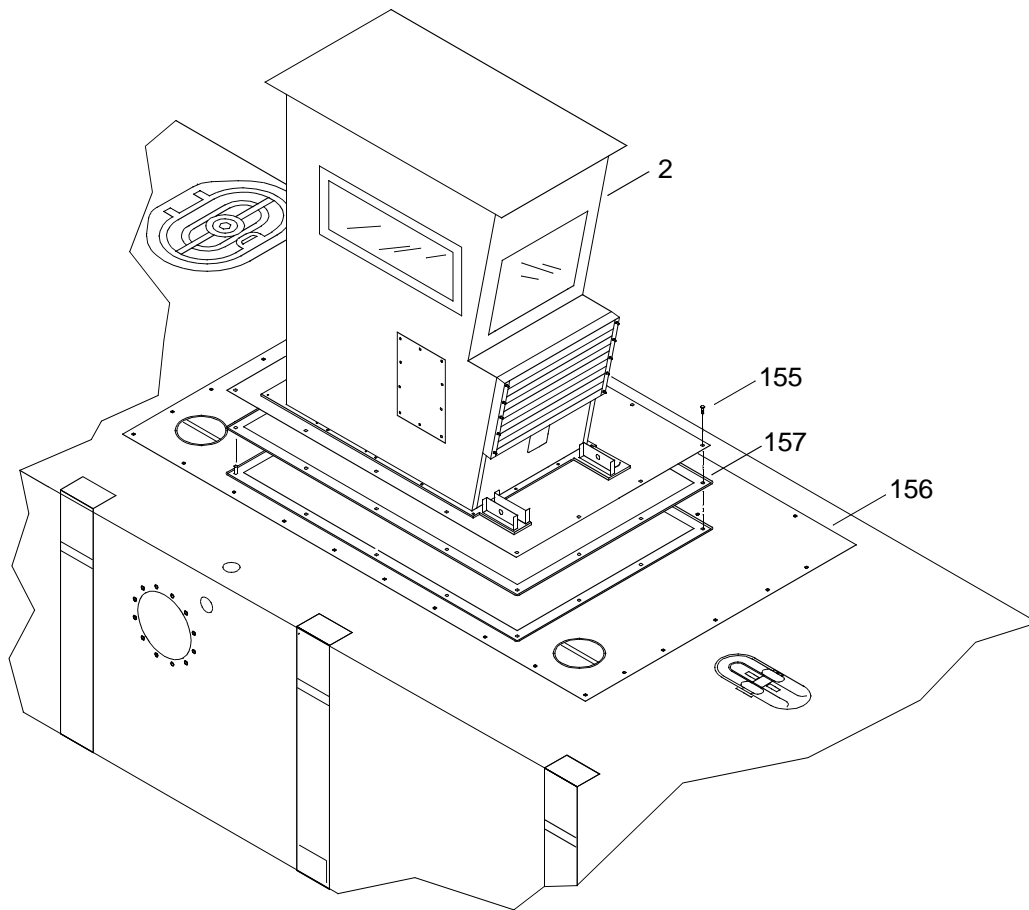
{4} Using crane, sling and shackle, remove spotlight (143) from spotlight flange tube (149).

{5} Stow spotlight (143) inside operators cab (2).

- f. Descend from top of operators cab (2) using steps on side of cab.
- g. Remove wire rope (150) in the operators cab (2) from the fire suppression trip mechanism (151).



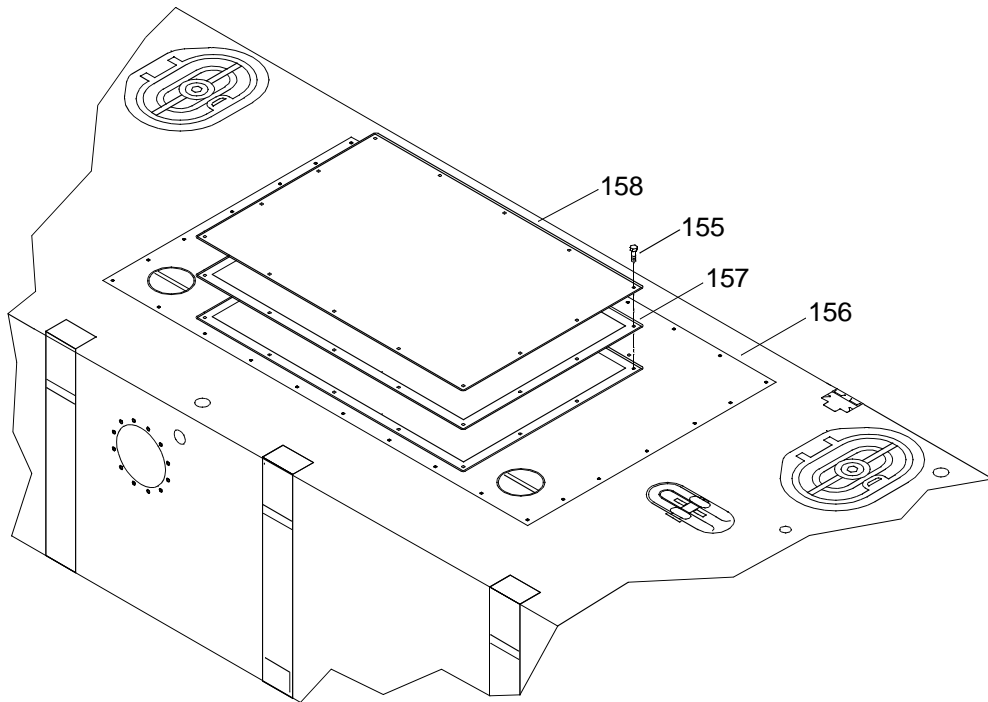
- {1} Move fire suppression solenoid spring flange (152) away from solenoid shaft (153).
 - {2} Remove wire rope ring (154) from the fire suppression solenoid shaft (153).
 - {3} Release flange (152).
- h. Remove bolts (155) attaching operators cab (2) to propulsion module engine hatch (156).



WARNING

**HEAVY PARTS**

- i. Using crane, slings and shackles, lift operators cab (2) from propulsion module engine hatch (156).
 - j. Remove gasket (157), if attached to operators cab.
 - k. Remove slings and shackles.
2. Install shipping plate (158) on starboard propulsion module engine hatch (156).



- a. Install gasket (157), if necessary.

WARNING



HEAVY PARTS

- b. Using crane, slings and shackles, align bolt holes in shipping plate (158) with holes in propulsion module engine hatch (156).
- c. Install bolts (155) to secure shipping plate (158) to starboard propulsion module engine hatch (156).
- d. Tighten bolts (155).
- e. Remove slings and shackles.

END OF WORK PACKAGE

**OPERATOR MAINTENANCE
CAUSEWAY FERRY
STABILIZERS
OPERATION UNDER USUAL CONDITIONS**

INITIAL SETUP:**Tools**

Tool Kit, General Mechanic's (Rail and Marine) (Item 76, WP 0105 00)
 Gloves, Men's and Women's (Leather Palm) (Item 31, WP 0105 00)
 Goggles, Sun, Wind and Dust (Safety) (Item 34, WP 0105 00)
 Life Preserver, Vest (Item 45, WP 0105 00)
 Helmet, Safety (Brown) (Item 40, WP 0105 00)
 2 Ton ½ in. Anchor Shackle (Item 1, WP 0105 00)
 Sling, Lifting, 5,300 lbs (Green) (Item 68, WP 0105 00)

Personnel Required

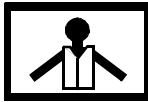
Seaman 88K

Equipment Condition

Safety Equipment Removed. (WP 0036 00)
 Fenders Removed. (WP 0037 00)
 D-Ring/Cloverleaf And Deck Cleat Fittings Removed. (WP 0038 00)
 Stub Navigation Mast Removed. (WP 0039 00)
 Anchorboard Assembly Removed. (WP 0040 00)
 Above Deck Equipment Removed. (WP 0041 00)

PREPARATION FOR MOVEMENT - REMOVE STABILIZERS

WARNING



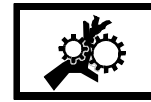
VEST



HELMET PROTECTION



HEAVY PARTS



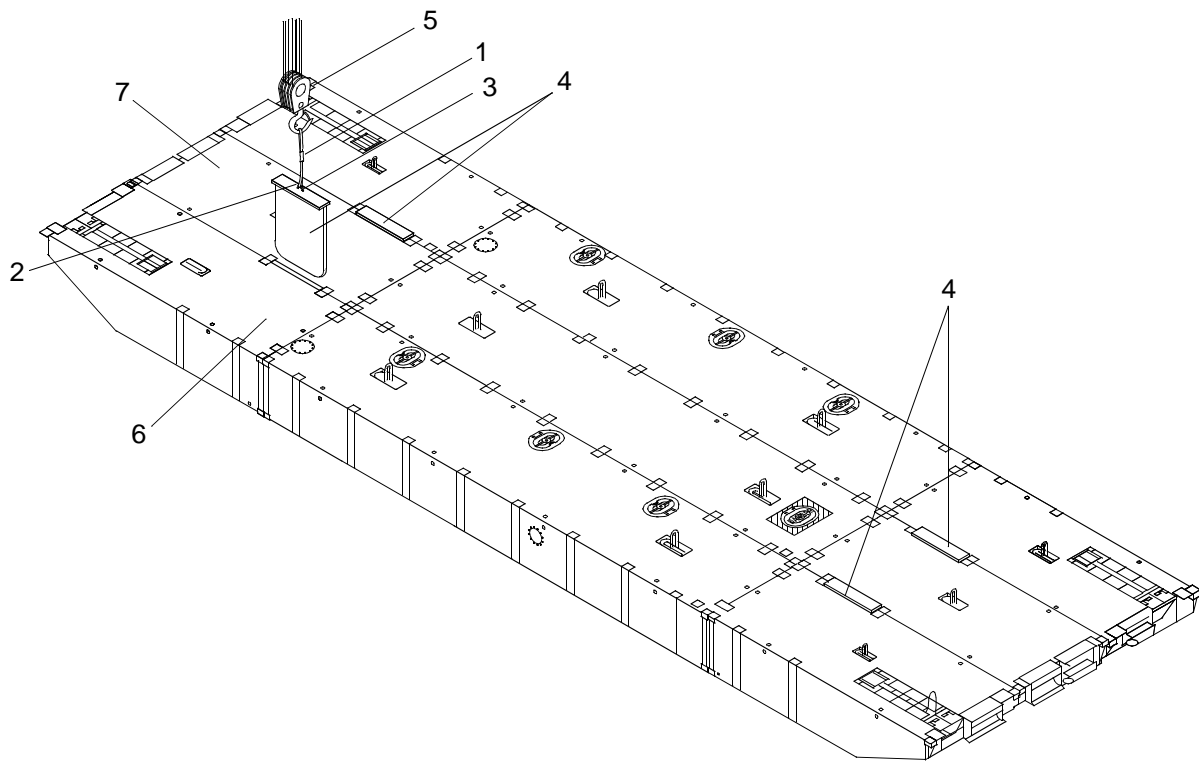
MOVING PARTS

All personnel must wear personal flotation device, hard hat, safety shoes and gloves during CF operations and maintenance. Failure to observe these precautions could result in serious injury or death.

NOTE

This task is typical for removal of stabilizers (skegs).

1. Attach sling (1) and shackle (2) to lifting eye (3) of stabilizer (4).



WARNING

**HEAVY PARTS**

2. Using crane (5), sling (1) and shackle (2), remove stabilizer (4) from space between outboard end rake (6) and center end rake (7).
3. Remove sling (1) and shackle (2) from lifting eye (3) of stabilizer (4).

END OF WORK PACKAGE

**OPERATOR MAINTENANCE
CAUSEWAY FERRY
POWERED SECTION
OPERATION UNDER USUAL CONDITIONS**

INITIAL SETUP:

Tools

- Tool Kit, General Mechanic's (Rail and Marine) (Item 76, WP 0105 00)
- Gloves, Men's and Women's (Leather Palm) (Item 31, WP 0105 00)
- Goggles, Sun, Wind and Dust (Safety) (Item 34, WP 0105 00)
- Life Preserver, Vest (Item 45, WP 0105 00)
- Helmet, Safety (Brown) (Item 40, WP 0105 00)
- Crowbar (Item 15, WP 0105 00)
- Sling, Lifting, 66,000 lb (Olive) (Item 71, WP 0105 00)
Qty 4
- 40 Ton, 1¾ in Alloy Anchor Shackle (Item 4, WP 0105 00)
Qty 4

Personnel Required

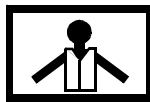
- Seaman 88K (2)

Equipment Condition

- Main Mast Lowered. (WP 0041 00)
-

PREPARATION FOR MOVEMENT - DISASSEMBLE CAUSEWAY FERRY POWERED SECTION ON DECK OF SEALIFT VESSEL

WARNING



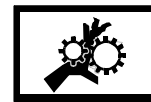
VEST



HELMET PROTECTION



HEAVY PARTS



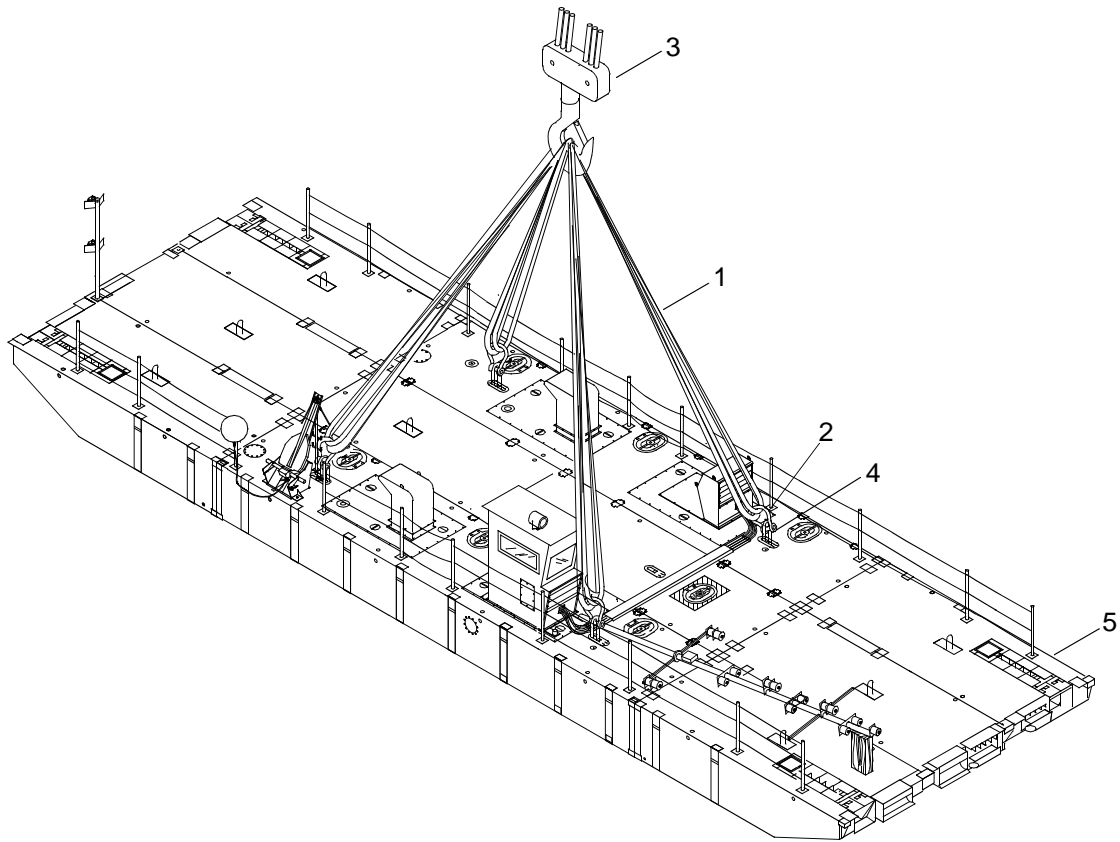
MOVING PARTS

All personnel must wear personal flotation device, hard hat, safety shoes and gloves during CF operations and maintenance. Failure to observe these precautions could result in serious injury or death.

Place hands on top or on the outside of ropes/lines so that in an emergency the lines can be released quickly to preclude being pulled into equipment. Failure to observe these precautions could result in serious injury or death.

DISASSEMBLE POWERED SECTION

1. Attach four 66,000 lb slings (1) and four 40-ton shackles (2) from crane (3) to padeye shackles (4) on powered section (5).

**WARNING****HEAVY PARTS**

2. Using slings (1), shackles (2) and crane (3), lift powered section (5) and place on deck of sealift vessel.
3. Remove shackles (2) from padeye shackles (4) on powered section (5).
4. Remove 66,000 lb slings (1) from crane (3).
5. Remove deck box. (WP 0035 10)
6. Remove crew shelter. (WP 0035 20)
7. Remove safety equipment. (WP 0036 00)
8. Remove fenders. (WP 0037 00)
9. Remove D-ring/cloverleaf fittings and deck cleats. (WP 0038 00)
10. Remove bow mast. (WP 0038 10)
11. Remove stub navigation mast. (WP 0039 00)

-
12. Remove anchorboard assembly. (WP 0040 00)
 13. Remove above deck equipment. (WP 0041 00)
 14. Remove stabilizers. (WP 0041 10)
 15. Operate male and female connectors. (WP 0008 00)
 16. Using crowbar, separate powered section into strings.
 17. Disassemble module strings. (WP 0046 00)
 18. Stow male and female guillotine connectors. (WP 0008 00)

END OF WORK PACKAGE

**OPERATOR MAINTENANCE
CAUSEWAY FERRY
POWERED SECTION
OPERATION UNDER USUAL CONDITIONS**

INITIAL SETUP:

Tools

- Tool Kit, General Mechanic's (Rail and Marine) (Item 76, WP 0105 00)
- Gloves, Men's and Women's (Leather Palm) (Item 31, WP 0105 00)
- Goggles, Sun, Wind and Dust (Safety) (Item 34, WP 0105 00)
- Life Preserver, Vest (Item 45, WP 0105 00)
- Helmet, Safety (Brown) (Item 40, WP 0105 00)
- Crowbar (Item 15, WP 0105 00)
- Sling, Lifting, 66,000 lb (Olive) (Item 71, WP 0105 00)
- 40 Ton, 1¾ in Alloy Anchor Shackle (Item 4, WP 0105 00)

Personnel Required

- Seaman 88K (2)

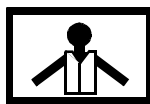
Equipment Condition

- Safety Equipment Removed. (WP 0036 00)
 - Fenders Removed. (WP 0037 00)
 - Bow Mast Removed. (WP 0038 10)
 - Stub Navigation Mast Removed. (WP 0039 00)
 - Anchorboard Assembly Removed. (WP 0040 00)
 - Above Deck Equipment Removed. (WP 0041 00)
 - Stabilizers Removed. (WP 0042 00)
-

PREPARATION FOR MOVEMENT - DISASSEMBLE CAUSEWAY FERRY POWERED SECTION IN WATER

DISASSEMBLY OF CAUSEWAY FERRY POWERED SECTION

WARNING



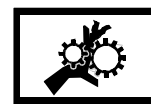
VEST



HELMET PROTECTION



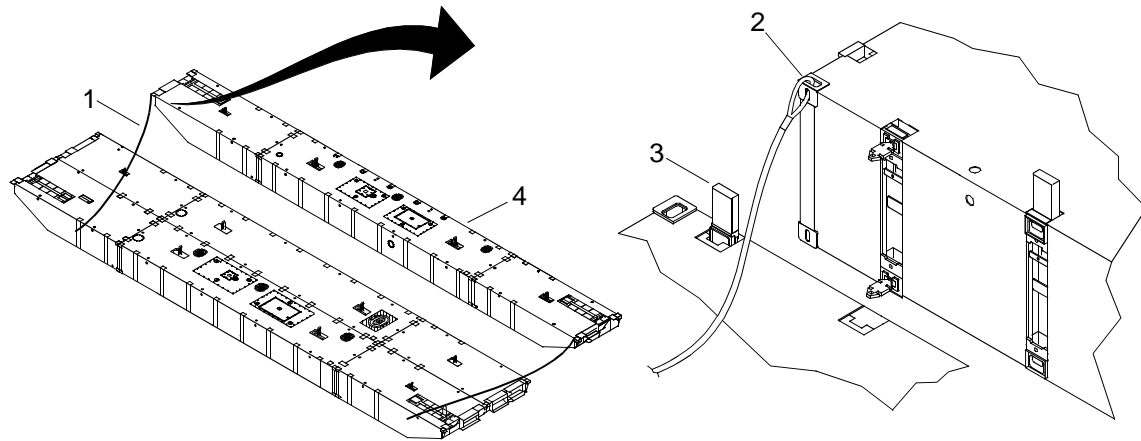
HEAVY PARTS



MOVING PARTS

All personnel must wear personal flotation device, hard hat, safety shoes and gloves during CF operations and maintenance. Failure to observe these precautions could result in serious injury or death.

1. Attach tag lines (1) to ISO corner fittings (2).



2. Operate female guillotine connectors (3). (WP 0008 00)
3. Using crowbar, separate causeway ferry powered section into module strings (4).

WARNING

Place hands on top or on the outside of ropes/lines so that in an emergency the lines can be released quickly to preclude being pulled into the equipment. Failure to observe these precautions could result in serious injury or death.

4. Using tag lines, maneuver module strings (4) into position for disassembly.
5. Disassemble module strings. (WP 0046 00)
6. Stow male and female guillotine connectors. (WP 0047 00)

END OF WORK PACKAGE

**OPERATOR MAINTENANCE
CAUSEWAY FERRY
OPERATION UNDER USUAL CONDITIONS**

INITIAL SETUP:**Tools**

Tool Kit, General Mechanic's (Rail and Marine) (Item 76, WP 0105 00)
 Gloves, Men's and Women's (Leather Palm) (Item 31, WP 0105 00)
 Goggles, Sun, Wind and Dust (Safety) (Item 34, WP 0105 00)
 Life Preserver, Vest (Item 45, WP 0105 00)
 Helmet, Safety (Brown) (Item 40, WP 0105 00)
 Crowbar (Item 15, WP 0105 00)

Personnel Required

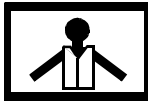
Seaman 88K

Equipment Condition

Removal Of Fenders. (WP 0037 00)

PREPARATION FOR MOVEMENT - DISASSEMBLY OF CAUSEWAY FERRY**DISASSEMBLE CAUSEWAY FERRY**

WARNING



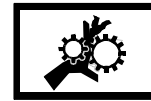
VEST



HELMET PROTECTION



HEAVY PARTS



MOVING PARTS

All personnel must wear personal flotation device, hard hat, safety shoes and gloves during CF operations and maintenance. Failure to observe these precautions could result in serious injury or death.

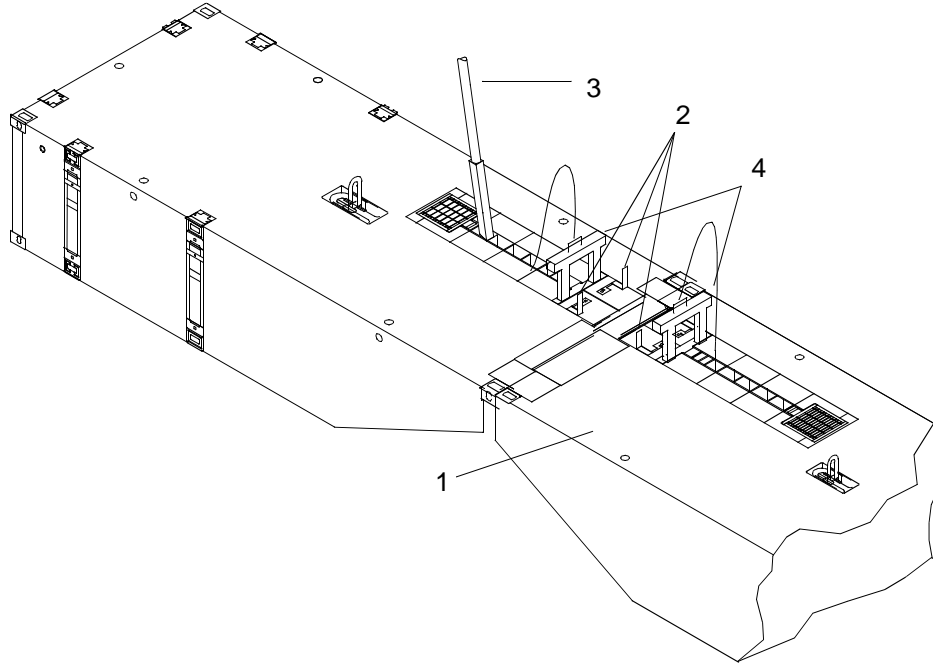
Do not handle ropes/lines by placing hands in bight of the line where it feeds into cleats, etc. Place the hands on top or on the outside, so in an emergency the lines can be released quickly to preclude being pulled into the equipment. Failure to observe these precautions could result in serious injury of death.

NOTE

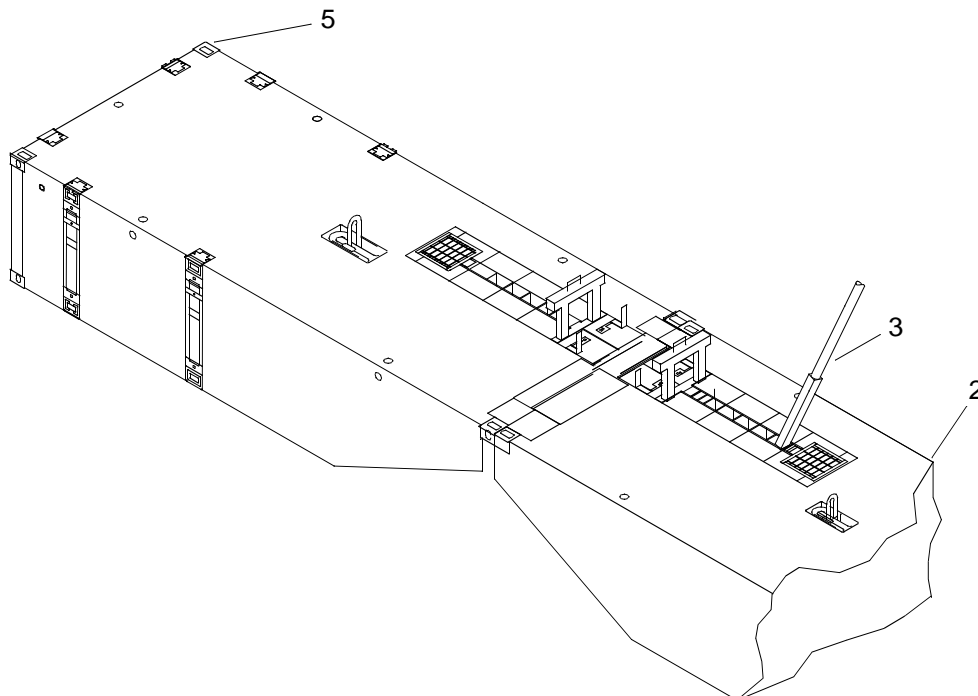
This task is typical for removal of intermediate sections and combination beach/sea end section.

1. Secure sections to be separated with lines to hold together.

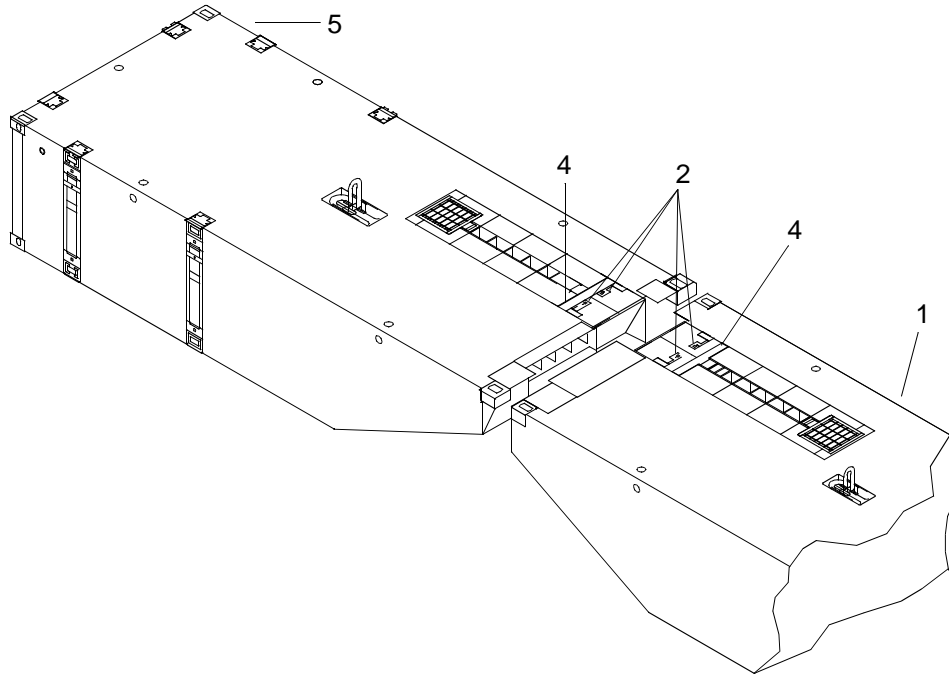
2. Release flexor connectors on right end rakes (1).



- a. Rotate the chute bolt handles (2) and pull the chute bolts (2) to the unlocked position.
 - b. Using the crowbar (3), lift the guillotine plates (4) up from the flexor connector slots.
 - c. Repeat step a and b for left end rake (5).
3. Stow flexor connectors in left end rakes (5).
 - a. Using crowbar (3), move flexor from right end rakes (1) into left end rakes (5) flexor connector pockets.



- b. Align outboard guillotine slot on flexor with slot in left rake module (5).



- c. Install guillotine plates (4) on left end rakes (5).
- d. Install guillotine plates (4) on right end rakes (1).
- e. Push chute bolts (2) to the locked position and rotate the chute bolt handles.
4. Using warping tugs, separate the CF from the combination beach/sea end section and intermediate sections.
5. Untie lines securing the sections and separate.

END OF WORK PACKAGE

**OPERATOR MAINTENANCE
CAUSEWAY FERRY
BEACH END SECTION
OPERATION UNDER USUAL CONDITIONS**

INITIAL SETUP:**Tools**

Tool Kit, General Mechanic's (Rail and Marine) (Item 76, WP 0105 00)
 Gloves, Men's and Women's (Leather Palm) (Item 31, WP 0105 00)
 Goggles, Sun, Wind and Dust (Safety) (Item 34, WP 0105 00)
 Life Preserver, Vest (Item 45, WP 0105 00)
 Helmet, Safety (Brown) (Item 40, WP 0105 00)
 Crowbar (Item 15, WP 0105 00)
 Sling, Lifting, 53,000 lb (Brown) (Item 67, WP 0105 00)
 Qty 4
 Sling, Lifting, 36,000 lb Adjustable Chain (Item 66, WP 0105 00)
 Qty 4

Personnel Required

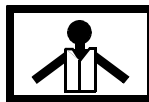
Seaman 88K (2)

Equipment Condition

Causeway Ferry Disassembled. (WP 0043 00)

**PREPARATION FOR MOVEMENT - DISASSEMBLY OF CAUSEWAY FERRY
BEACH END (CFBE) SECTION**

WARNING



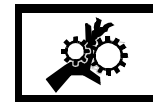
VEST



HELMET PROTECTION



HEAVY PARTS

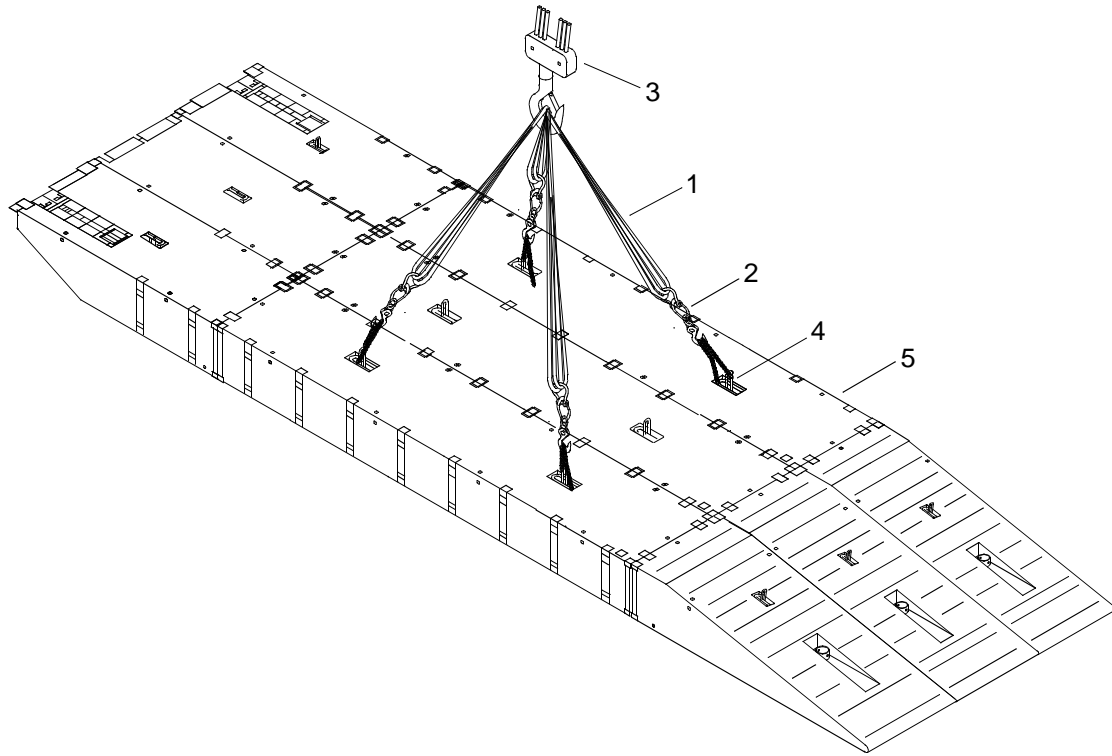


MOVING PARTS

All personnel must wear personal flotation device, hard hat, safety shoes and gloves during CF operations and maintenance. Failure to observe these precautions could result in serious injury or death.

**DISASSEMBLY OF CAUSEWAY FERRY BEACH END SECTION ON THE
SEALIFT VESSEL**

1. Attach four 53,000 lb slings (1) and four 36,000 lb adjustable chain slings (2) from crane (3) to padeye shackles (4) on causeway ferry beach end section (5).



WARNING

**HEAVY PARTS**

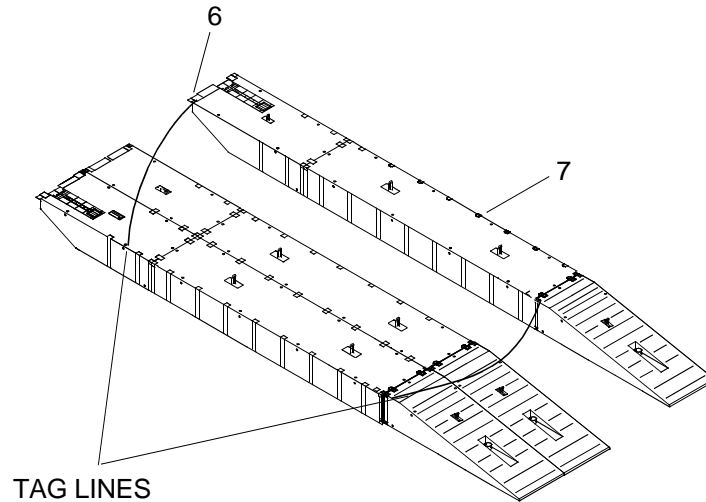
2. Using slings (1 and 2) and crane (3), lift causeway ferry beach end section (5) and place on deck of sealift vessel.
3. Remove 36,000 lb adjustable chain slings (2) from padeye shackles (4) on causeway ferry beach end section (5).
4. Remove 53,000 lb slings (1) from crane (3).
5. Operate female guillotine connectors. (WP 0008 00)
6. Using crowbar, separate CFBE section into module strings.
7. Stow male and female guillotine connectors. (WP 0047 00)
8. Disassemble module strings. (WP 0046 00)

DISASSEMBLY OF CAUSEWAY FERRY BEACH END SECTION IN WATER

NOTE

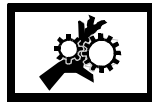
This procedure is typical of separating CFBE intermediate sections into module strings.

1. Attach tag lines to ISO corner fittings (6).



2. Operate female guillotine connectors. (WP 0008 00)
3. Using crowbar, separate CFBE sections into module strings (7).

WARNING

**MOVING PARTS**

Place hands on top or on the outside of ropes/lines so that in an emergency the lines can be released quickly to preclude being pulled into the equipment. Failure to observe these precautions could result in serious injury or death.

4. Using tag lines, maneuver module strings (7) into position for disassembly.
5. Stow male and female guillotine connectors. (WP 0047 00)
6. Disassemble module strings (7). (WP 0046 00)

END OF WORK PACKAGE

**OPERATOR MAINTENANCE
CAUSEWAY FERRY
INTERMEDIATE SECTION
OPERATION UNDER USUAL CONDITIONS**

INITIAL SETUP:**Tools**

Tool Kit, General Mechanic's (Rail and Marine) (Item 76, WP 0105 00)
 Gloves, Men's and Women's (Leather Palm) (Item 31, WP 0105 00)
 Goggles, Sun, Wind and Dust (Safety) (Item 34, WP 0105 00)
 Life Preserver, Vest (Item 45, WP 0105 00)
 Helmet, Safety (Brown) (Item 40, WP 0105 00)
 Crowbar (Item 15, WP 0105 00)
 Sling, Lifting, 53,000 lb (Brown) (Item 49, WP 0105 00)
 Qty 4
 Sling, Lifting, 36,000 lb Adjustable Chain (Item 48, WP 0105 00)
 Qty 4

Personnel Required

Seaman 88K

Equipment Condition

Causeway Ferry Disassembled. (WP 0043 00)

PREPARATION FOR MOVEMENT - DISASSEMBLE INTERMEDIATE SECTION

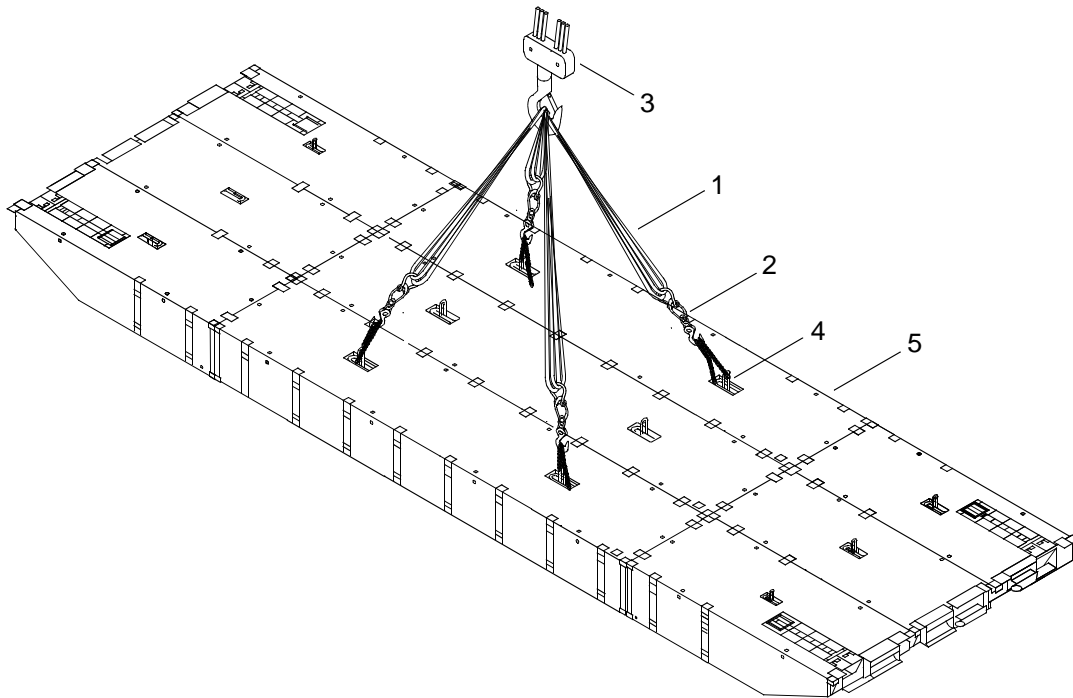
WARNING

**VEST****HELMET PROTECTION****HEAVY PARTS****MOVING PARTS**

All personnel must wear personal flotation device, hard hat, safety shoes and gloves during CF operations and maintenance. Failure to observe these precautions could result in serious injury or death.

DISASSEMBLE INTERMEDIATE SECTION ON DECK OF SEALIFT VESSEL

1. Attach four 53,000 lb slings (1) and four 36,000 lb adjustable chain slings (2) from crane (3) to padeye shackles (4) on intermediate section (5).



WARNING

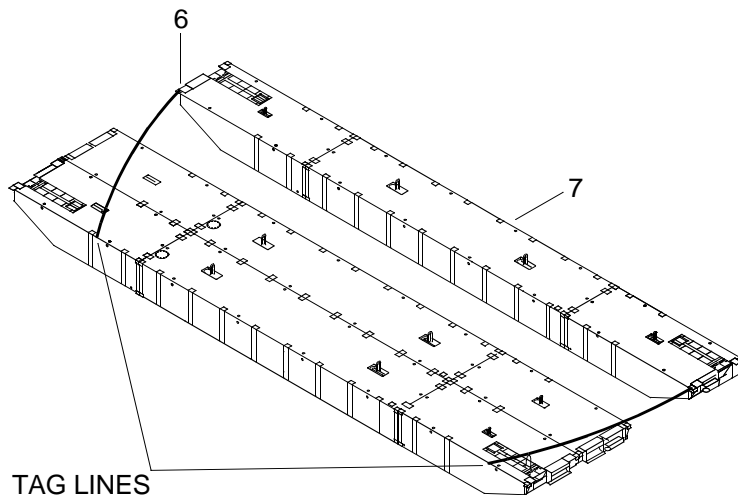
**HEAVY PARTS**

2. Using slings (1 and 2) and crane (3), lift intermediate section (5) and place on deck of sealift vessel.
3. Remove 36,000 lb adjustable chain slings (2) from padeye shackles (4) on intermediate section (5).
4. Remove 53,000 lb slings (1) from crane (3).
5. Raise female guillotine connectors. (WP 0008 00)
6. Using crowbar, separate intermediate section into strings.
7. Stow male and female guillotine connectors. (WP 0047 00)
8. Disassemble module strings. (WP 0046 00)

DISASSEMBLY OF INTERMEDIATE SECTION IN WATER**NOTE**

This procedure is typical of separating intermediate sections into module strings.

1. Attach tag lines to ISO corner fittings (6).



2. Operate female guillotine connectors. (WP 0008 00)
3. Using crowbar, separate intermediate sections into module strings.

WARNING

Place hands on top or on the outside of ropes/lines so that in an emergency the lines can be released quickly to preclude being pulled into the equipment. Failure to observe these precautions could result in serious injury or death.

4. Using tag lines, maneuver module strings (7) into position for disassembly.
5. Stow male and female guillotine connectors. (WP 0047 00)
6. Disassemble module strings. (WP 0046 00)

END OF WORK PACKAGE

**OPERATOR MAINTENANCE
CAUSEWAY FERRY
MODULE STRINGS
OPERATION UNDER USUAL CONDITIONS**

INITIAL SETUP:**Tools**

Tool Kit, General Mechanic's (Rail and Marine) (Item 76, WP 0105 00)
 Gloves, Men's and Women's (Leather Palm) (Item 31, WP 0105 00)
 Goggles, Sun, Wind and Dust (Safety) (Item 34, WP 0105 00)
 Life Preserver, Vest (Item 45, WP 0105 00)
 Helmet, Safety (Brown) (Item 40, WP 0105 00)
 Crowbar (Item 15, WP 0105 00)
 Sling, Lifting, 8,400 lb (Yellow) (Item 72, WP 0105 00)
 Qty 4
 Sling, Lifting, 36,000 lb Adjustable Chain (Item 66, WP 0105 00)
 Qty 4

Personnel Required

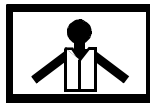
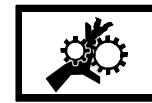
Seaman 88K (2)

Equipment Condition

Stabilizers Removed. (WP 0040 10)
 Causeway Ferry Disassembled. (WP 0043 00)
 Intermediate Section Disassembled. (WP 0045 00)
 CFBE Section Disassembled. (WP 0044 00)

PREPARATION FOR MOVEMENT - DISASSEMBLY OF MODULE STRINGS

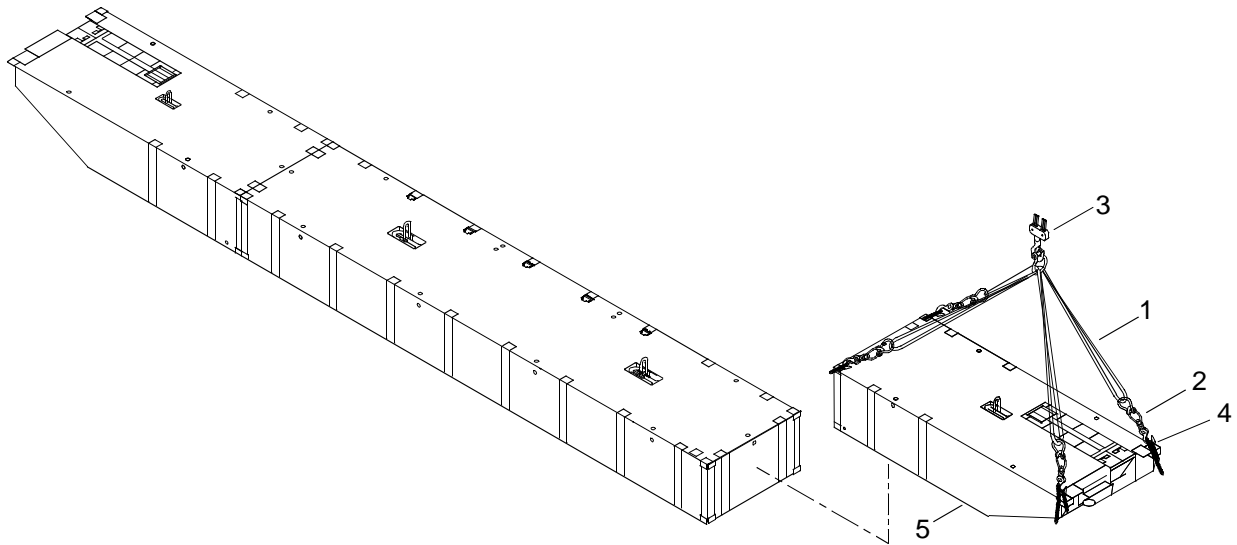
WARNING

**VEST****HELMET PROTECTION****HEAVY PARTS****MOVING PARTS**

All personnel must wear personal flotation device, hard hat, safety shoes and gloves during CF operations and maintenance. Failure to observe these precautions could result in serious injury or death.

DISASSEMBLY OF MODULE STRINGS ON DECK OF SEALIFT VESSEL

1. Operate female guillotine connectors. (WP 0008 00)
2. Using crowbar, separate modules.
3. Attach four 8,400 lb slings (1) and four 36,000 lb adjustable chain slings (2) from crane (3) to corners (4) on end rake module (5).



WARNING

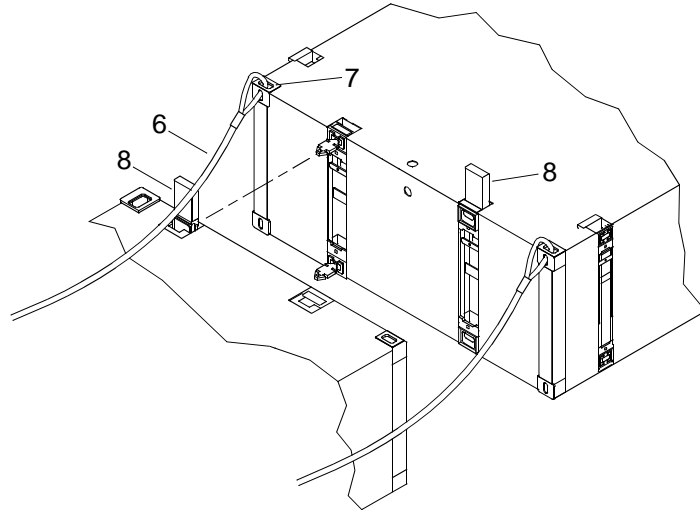
**HEAVY PARTS**

4. Using slings (1 and 2) and crane (3), lift end rake module (5) and place into position for ISOPAK assembly.
5. Remove 36,000 lb adjustable chain slings (2) from corners (4) on end rake module (5).
6. Remove 8,400 lb slings (1) from crane (3).
7. Repeat steps 3 through 6 for other end rake.
8. Stow male and female guillotine connectors. (WP 0047 00)
9. Assemble module ISOPAK. (WP 0049 00)

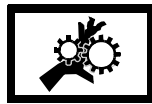
DISASSEMBLY OF MODULE STRINGS IN WATER**NOTE**

This procedure is typical of separating module strings.

1. Attach tag lines (6) to ISO corner fittings (7).



2. Operate female guillotine connectors (8). (WP 0008 00)
3. Using crowbar, separate module strings.

WARNING**MOVING PARTS**

Place hands on top or on the outside of ropes/lines so that in an emergency the lines can be released quickly to preclude being pulled into the equipment. Failure to observe these precautions could result in serious injury or death.

4. Using tag lines (6) maneuver modules into position for module ISOPAK assembly.
5. Stow male and female guillotine connectors. (WP 0047 00)
6. Assemble module ISOPAK. (WP 0049 00)

END OF WORK PACKAGE

**OPERATOR MAINTENANCE
CAUSEWAY FERRY
MALE AND FEMALE GUILLOTINE CONNECTORS
OPERATION UNDER USUAL CONDITIONS**

INITIAL SETUP:**Tools**

Tool Kit, General Mechanic's (Rail and Marine) (Item 76, WP 0105 00)
 Gloves, Men's and Women's (Leather Palm) (Item 31, WP 0105 00)
 Goggles, Sun, Wind and Dust (Safety) (Item 34, WP 0105 00)
 Life Preserver, Vest (Item 45, WP 0105 00)
 Helmet, Safety (Brown) (Item 40, WP 0105 00)
 Hammer, Hand (10 lb Sledge) (Item 36, WP 0105 00)
 Crowbar (Item 15, WP 0105 00)
 Pin Retraction Tool (Item 83, WP 0105 00)

Personnel Required

Seaman 88K

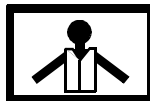
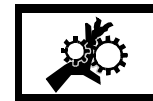
Equipment Condition

Crew Shelter Removed (WP 0035 20)
 Safety Equipment Removed. (WP 0036 00)
 Fenders Removed. (WP 0037 00)
 D-Ring/Cloverleaf Fittings And Deck Cleats Removed. (WP 0038 00)
 Stub Navigation Mast Removed. (WP 0039 00)
 Anchorboard Assembly Removed. (WP 0040 00)
 Causeway Ferry Above Deck Equipment Removed. (WP 0041 00)
 Causeway Ferry Powered Section Disassembled. (WP 0042 00 or WP 0042 10)
 Causeway Ferry Disassembled. (WP 0043 00)
 Causeway Ferry Beach End Section Disassembled. (WP 0044 00)
 Intermediate Section Disassembled. (WP 0045 00)
 Module Strings Disassembled. (WP 0046 00)

**PREPARATION FOR MOVEMENT - STOWAGE OF MALE AND FEMALE
GUILLOTINE CONNECTORS**

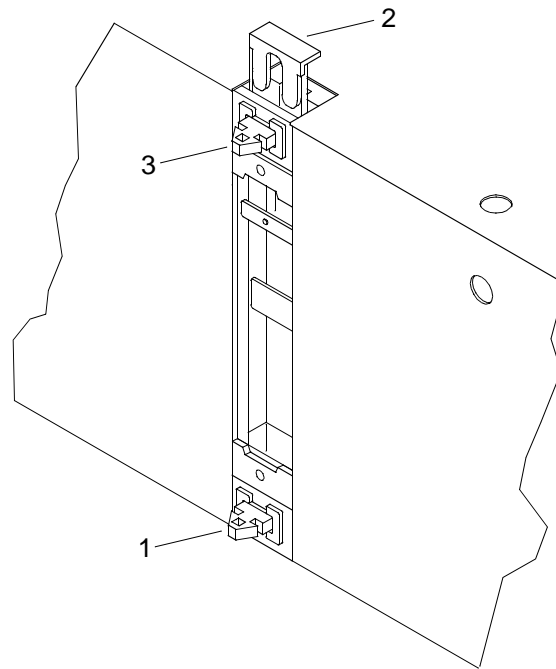
STOW MALE CONNECTORS

WARNING

**VEST****HELMET PROTECTION****HEAVY PARTS****MOVING PARTS**

All personnel must wear personal flotation device, hard hat, safety shoes and gloves during CF operations and maintenance. Failure to observe these precautions could result in serious injury or death.

1. While holding lower male lock pin (1) fully inward against its deployment spring, lower guillotine connector (2) with sledgehammer to partially engage and restrain lower male lock pin (1).



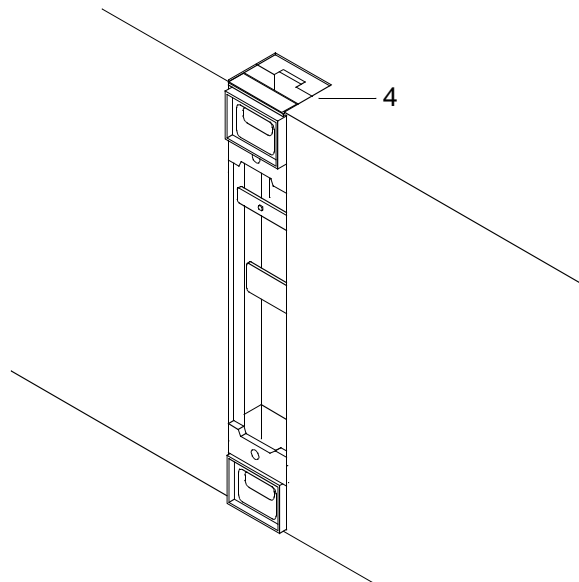
2. While holding upper lock pin (3) inward against deployment spring, complete lowering guillotine connector (2) with sledgehammer to engage and restrain both pins (1, 3).

STOW FEMALE CONNECTORS

NOTE

Guillotine connectors are properly stowed when flush with module deck.

1. Using sledgehammer, strike guillotine (4) of female connectors until flush with deck.

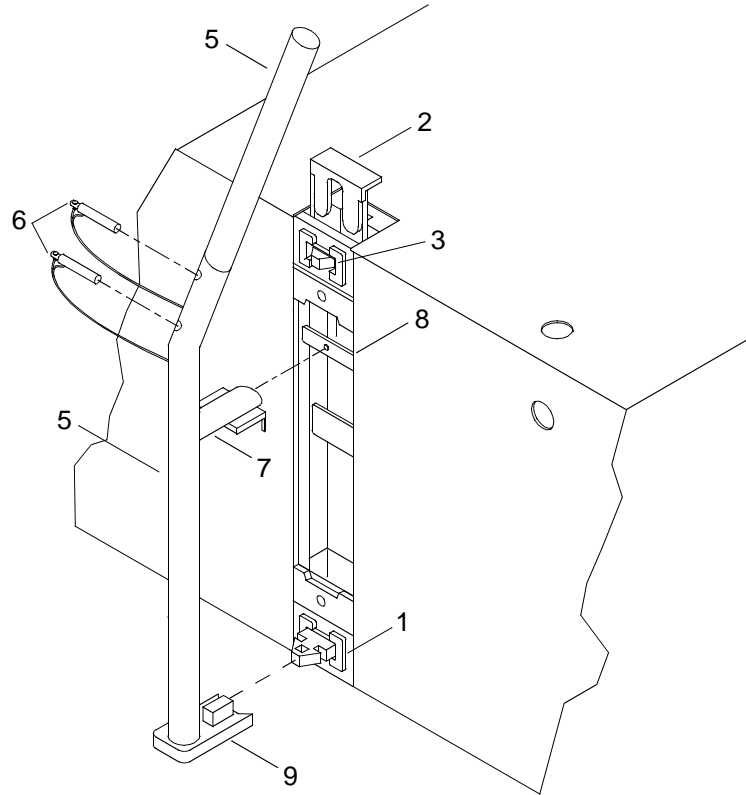


2. Verify all guillotines (4) are flush with module deck.

STOW LOWER MALE CONNECTORS USING PIN RETRACTION TOOL**NOTE**

If module is in water and lower pins (1) require stowage, use pin retraction tool (5).

1. Assemble two piece pin retraction tool (5) and secure with two quick release pins (6).



2. Rest pin retraction tool support fitting (7) on guillotine cross bracket (8).
3. Position foot (9) of pin retraction tool (5) over lower pin (1) and press inwards by levering pin retraction tool (5) upwards.
4. Lower guillotine (2) with sledgehammer to partially engage and restrain lower pin (1).
5. Remove pin retraction tool (5).
6. While holding upper lock pin (3) inward against deployment spring, complete lowering guillotine connector (2) with sledgehammer to engage and restrain both pins (1, 3).

END OF WORK PACKAGE

**OPERATOR MAINTENANCE
CAUSEWAY FERRY
FLEXOR CONNECTOR
STOWAGE**

THIS WORK PACKAGE DELETED DUE TO CONFIGURATION CHANGE.



**OPERATOR MAINTENANCE
CAUSEWAY FERRY
MODULE ISOPAK
OPERATION UNDER USUAL CONDITIONS**

INITIAL SETUP:**Tools**

Tool Kit, General Mechanic's (Rail and Marine) (Item 76, WP 0105 00)
 Gloves, Men's and Women's (Leather Palm) (Item 31, WP 0105 00)
 Goggles, Sun, Wind and Dust (Safety) (Item 34, WP 0105 00)
 Life Preserver, Vest (Item 45, WP 0105 00)
 Helmet, Safety (Brown) (Item 40, WP 0105 00)
 Ladder (Item 43, WP 0105 00)
 Sling, Lifting, 8,400 lb (Yellow) (Item 72, WP 0105 00)
 Qty 4
 Sling, Lifting, 66,000 lb (Olive) (Item 71, WP 0105 00)
 Qty 2
 Sling, Lifting, 53,000 lb (Brown) (Item 67, WP 0105 00)
 Qty 2
 Sling, Lifting, 36,000 lb Adjustable Chain (Item 66, WP 0105 00)
 Qty 4

Personnel Required

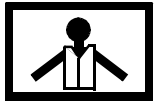
Seaman 88K (2)

Equipment Condition

Crew Shelter Removed (WP 0035 20)
 Safety Equipment Removed. (WP 0036 00)
 Fenders Removed. (WP 0037 00)
 D-Ring/Cloverleaf And Deck Cleat Fittings Removed. (WP 0038 00)
 Bow Mast Removed (WP 0038 10)
 Stub Navigation Mast Removed. (WP 0039 00)
 Anchorboard Assembly Removed. (WP 0040 00)
 Causeway Ferry Above Deck Equipment Removed. (WP 0041 00)
 Causeway Ferry Powered Section Disassembled. (WP 0042 00)
 Causeway Ferry Disassembled. (WP 0043 00)
 Causeway Ferry Beach End Section Disassembled. (WP 0044 00)
 Intermediate Section Disassembled. (WP 0045 00)
 Module Strings Disassembled. (WP 0046 00)
 Male And Female Connectors Stowed. (WP 0047 00)

PREPARATION FOR MOVEMENT - ASSEMBLY OF MODULE ISOPAK**ASSEMBLE NON-POWERED MODULE ISOPAK**

 WARNING



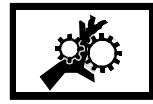
VEST



HELMET PROTECTION



HEAVY PARTS



MOVING PARTS



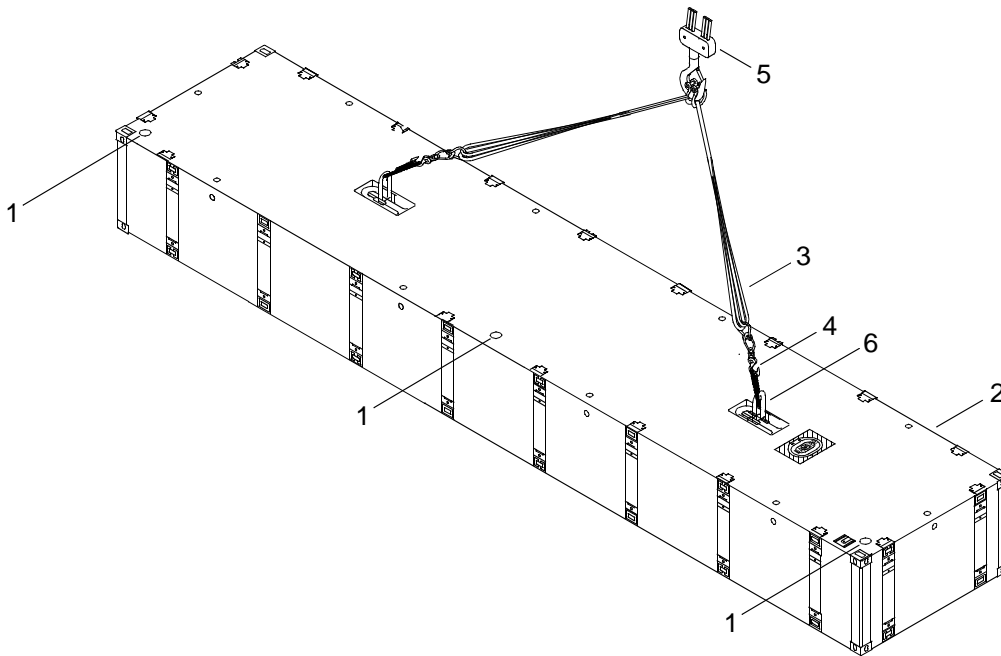
HEAVY PARTS

All personnel must wear personal flotation device, hard hat, safety shoes and gloves during CF operations and maintenance. Failure to observe these precautions could result in serious injury or death.

NOTE

Modules must remain level when lifting with slings.

1. Verify drain plugs (1) on center module (2) are installed.



2. Using ladder, climb on top of center module (2).
3. Attach two 53,000 lb slings (3) and two 36,000 lb adjustable chain slings (4) from crane (5) to padeyes (6) on center module (2).
4. Descend from top of module (2) and remove ladder.

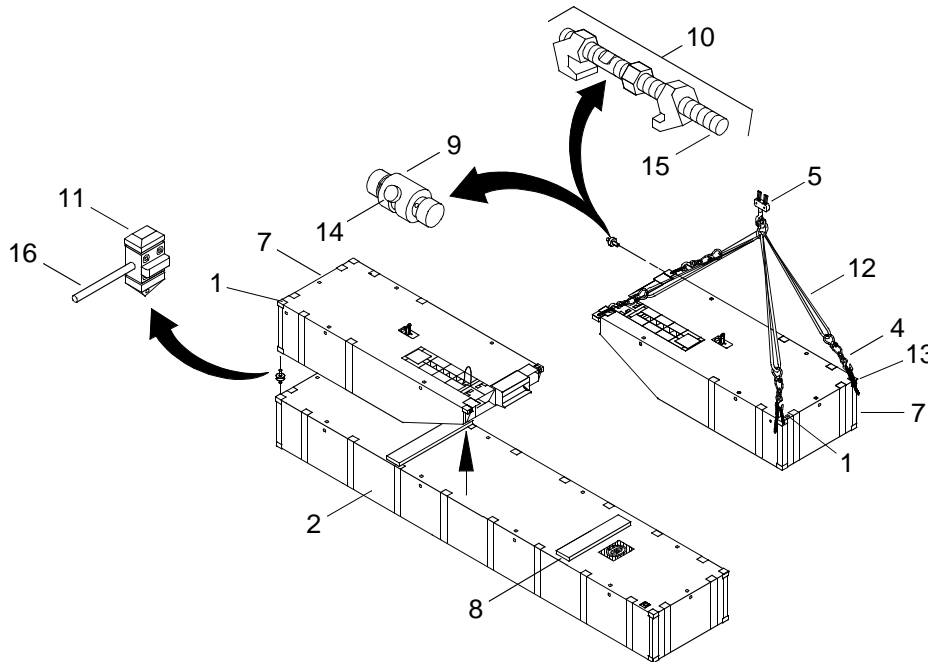
 WARNING



HEAVY PARTS

5. Using slings (3 and 4) and crane (5), lift center module (2) and position for assembly.

6. Remove 36,000 lb adjustable chain slings (4) from padeyes (6) on center module (2).
7. Remove 53,000 lb slings (3) from crane (5).
8. Verify drain plugs (1) on end rake modules (7) are installed.



9. Install dunnage (8) on top of center module (2).

NOTE

Either horizontal twist locks or bridge locks are used to connect two end rake modules.

10. Install two horizontal connectors (9 or 10) into end rake modules (7).
11. Install four vertical connectors (11) into corners of center module (2).
12. Attach four 8,400 lb slings (12) and four 36,000 lb adjustable chain slings (4) from crane (5) to corners (13) on end rake module (7).

WARNING



HEAVY PARTS

13. Using slings (4 and 12) and crane (5), lift end rake module (7) onto top of center module (2).
14. Using ladder, remove 8,400 lb slings (12) and 36,000 lb adjustable chain slings (4) from corners (13) on end rake module (7).
15. Attach four 8,400 lb slings (12) and four 36,000 lb adjustable chain slings (4) from crane (5) to corners (13) on second end rake module (7).

WARNING

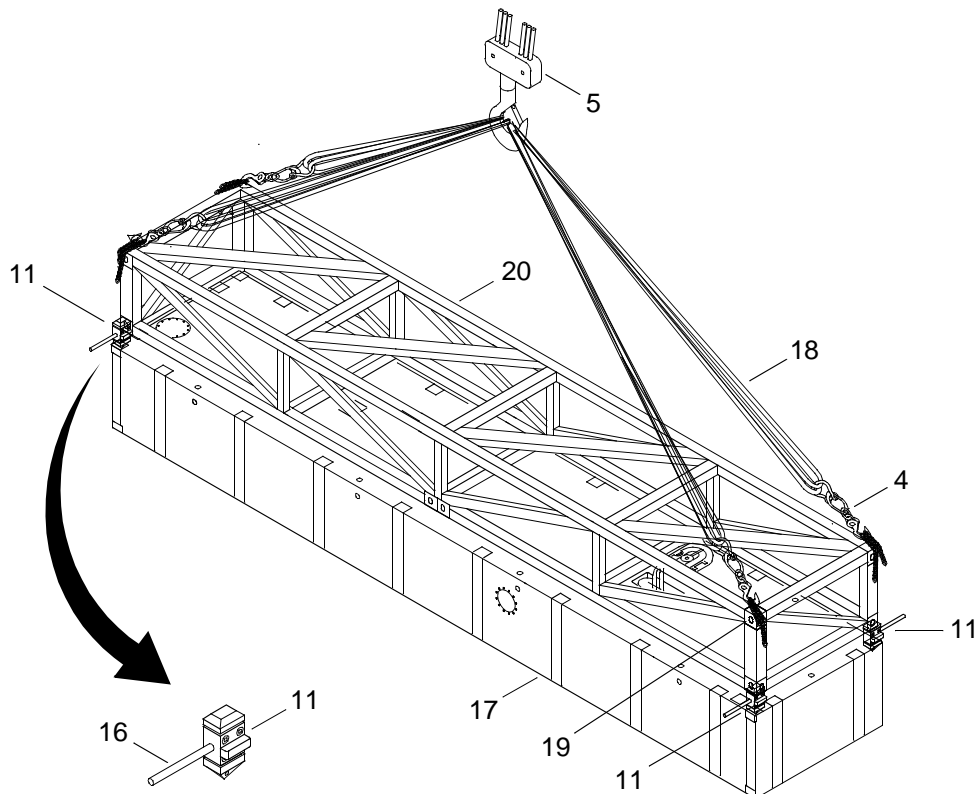
**HEAVY PARTS**

16. Using slings (4 and 12) and crane (5), lift end rake module (7) onto top of center module (2).
17. Using ladder, remove 36,000 lb adjustable chain slings (4) from corners (13) on end rake module (7).
18. Remove 8,400 lb slings (12) from crane (5).
19. Lock two horizontal twist locks (9) or bridge locks (10).
 - a. Lock two horizontal twist locks (9) by rotating levers (14).
 - b. Lock two bridge locks (10) by tightening jack screws (15).
20. Lock four vertical connectors (11) by rotating levers (16).
21. Descend from ladder and remove from ISOPAK.

INSTALL EMPTY SHIPPING FRAME ON POWER MODULE**NOTE**

This procedure is typical for both power modules.

1. Install four vertical connectors (11) on corners of power module (17).



- Attach two 66,000 lb slings (18) and four 36,000 lb adjustable chain slings (4) from crane (5) to ISO corners (19) on shipping frame (20).

WARNING

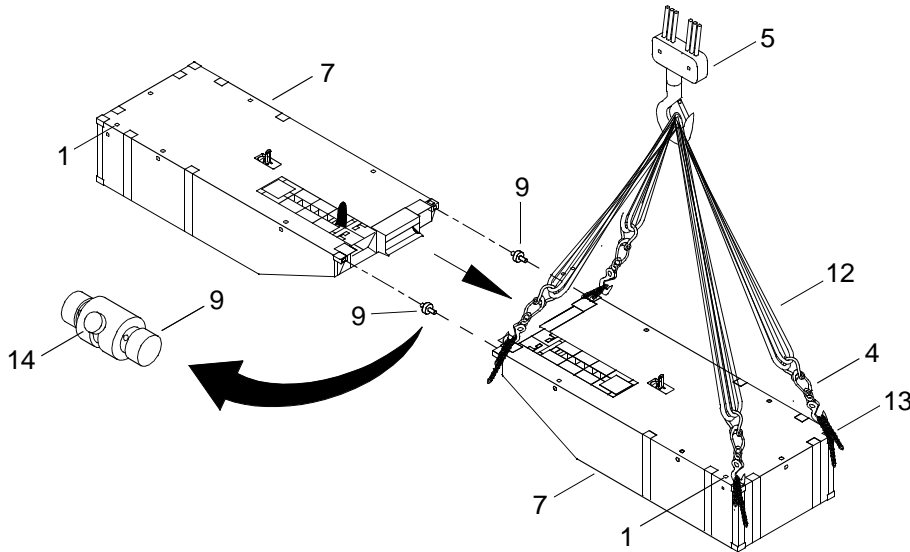


HEAVY PARTS

- Using crane and slings, lift shipping frame (20) and place on top of power module (17).
- Lock four vertical connectors (11), one at each corner, by rotating lever (16).
- Using ladder, climb on top of shipping frame (20).
- Remove 36,000 lb adjustable chain slings (4) from ISO corners (19) of frame (20).
- Remove 66,000 lb slings (18) from crane (5).
- Descend from top of shipping frame (20).

INSTALL MAIN MAST SHIPPING FRAME ON END RAKE MODULES

- Verify drain plugs (1) on end rake modules (7) are installed.



NOTE

Either horizontal twist locks or bridge locks are used to connect two end rake modules.

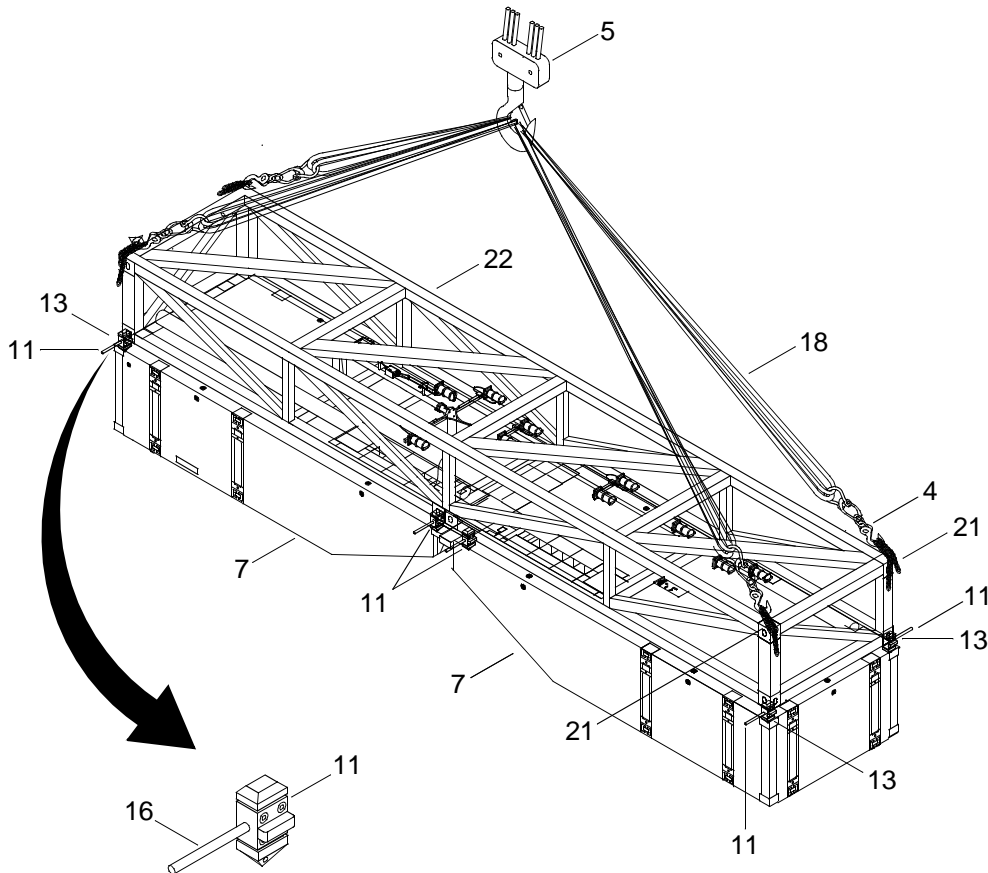
Left and right end rake modules are rigged and lifted in same manner.

- Install two horizontal connectors (9) into one end rake module (7).
- Attach four 8,400 lb slings (12) and 36,000 lb adjustable chain slings (4) from crane (5) to corners (13) on end rake module (7).

WARNING

**HEAVY PARTS**

4. Using slings (4 and 12) and crane (5), lift and position end rake modules (7) nose to nose.
5. Using ladder, climb on top of end rake modules (7).
6. Connect end rake modules (7) nose to nose with two horizontal connectors (9 or 10).
7. Lock two horizontal connectors (9 or 10) by rotating levers (14) or tightening jack screws (15).
8. Remove 36,000 lb adjustable chain slings (4) from corners (13) on end rake module (7).
9. Remove 8,400 lb slings (12) from crane (5).
10. Descend from top of end rake modules (7) and remove ladder.
11. Install eight vertical connectors (11) on corners (13) of end rake modules (7).



12. Attach two 66,000 lb slings (18) and 36,000 lb adjustable chain slings (4) from crane (5) to ISO corners (21) on main mast shipping frame (22).

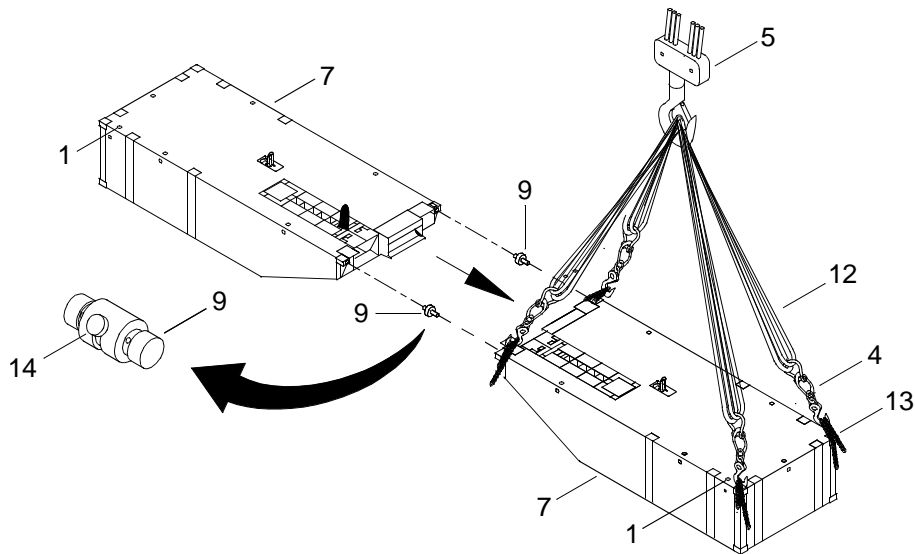
WARNING

**HEAVY PARTS**

13. Using crane and slings, lift main mast shipping frame (22) and place on top of end rake modules (7).
14. Lock eight vertical connectors (11), one at each corner, by rotating lever (16).
15. Using ladder, climb on top of shipping frame (22).
16. Remove 36,000 lb adjustable chain slings (4) from ISO corners (21) of shipping frame (22).
17. Remove 66,000 lb slings (18) from crane (5).
18. Descend from top of shipping frame (22).

INSTALL PLENUM SHIPPING FRAME ON END RAKE MODULES

1. Verify drain plugs (1) on end rake modules (7) are installed.

**NOTE**

Either horizontal twist locks or bridge locks are used to connect two end rake modules.

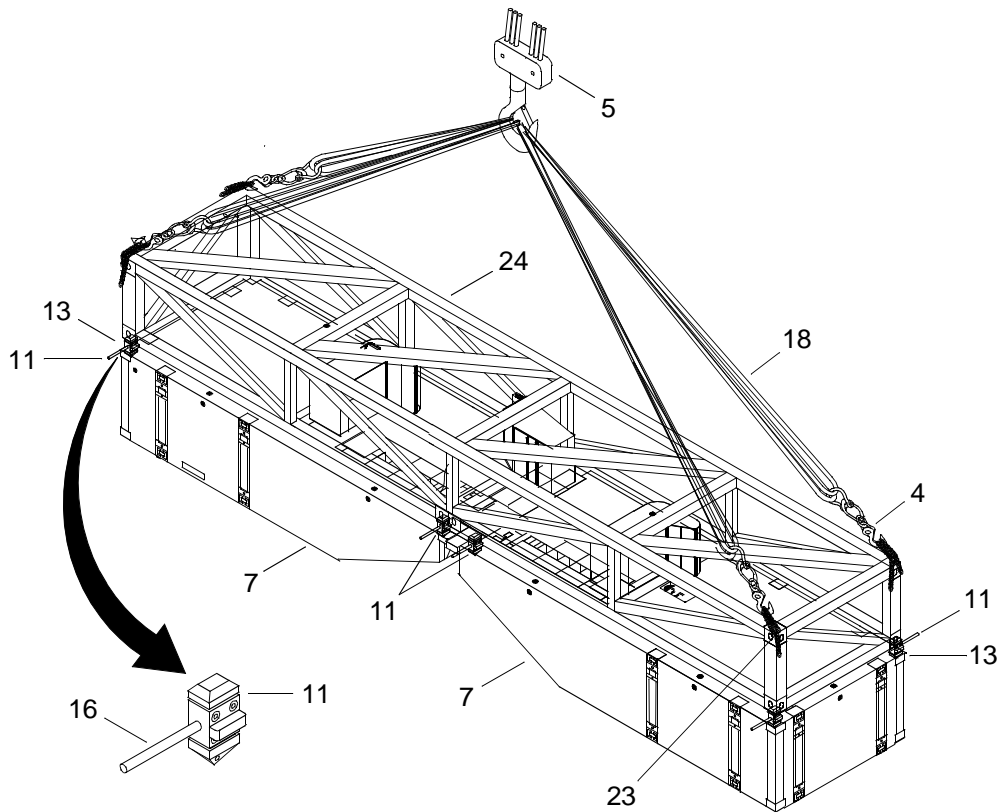
Left and right end rake modules are rigged and lifted in same manner.

2. Install two horizontal connectors (9 or 10) into one end rake module (7).
3. Attach four 8,400 lb slings (12) and 36,000 lb adjustable chain slings (4) from crane (5) to corners (13) on end rake module (7).

WARNING

**HEAVY PARTS**

4. Using slings (4 and 12) and crane (5), lift and position two end rake modules (7) nose to nose.
5. Connect end rake modules (7) nose to nose with two horizontal connectors (9 or 10).
6. Lock two horizontal connectors (9 or 10) by rotating levers (14) or tightening jack screws (15).
7. Remove 36,000 lb adjustable chain slings (4) from corners (13) on end rake module (7).
8. Remove 8,400 lb slings (12) from crane (5).
9. Install eight vertical connectors (11) on corners (13) of end rake modules (8).



10. Attach two 66,000 lb slings (18) and 36,000 lb adjustable chain slings (4) from crane (5) to ISO corners (23) of plenum shipping frame (24).

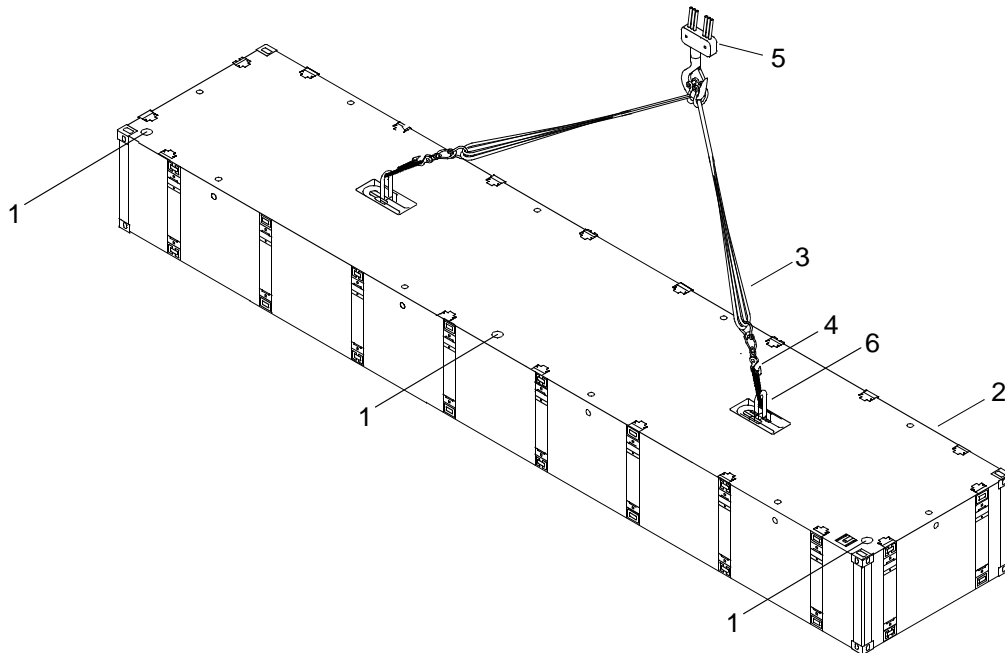
WARNING

**HEAVY PARTS**

11. Using crane and slings, lift shipping frame (24) and place on top of end rake modules (7).
12. Lock eight vertical connectors (11), one at each corner, by rotating lever (16).
13. Using ladder, climb on top of shipping frame (24).
14. Remove 36,000 lb adjustable chain slings (4) from ISO corners (23) on shipping frame (24).
15. Remove 66,000 lb slings (18) from crane (5).
16. Descend from top of shipping frame (24).

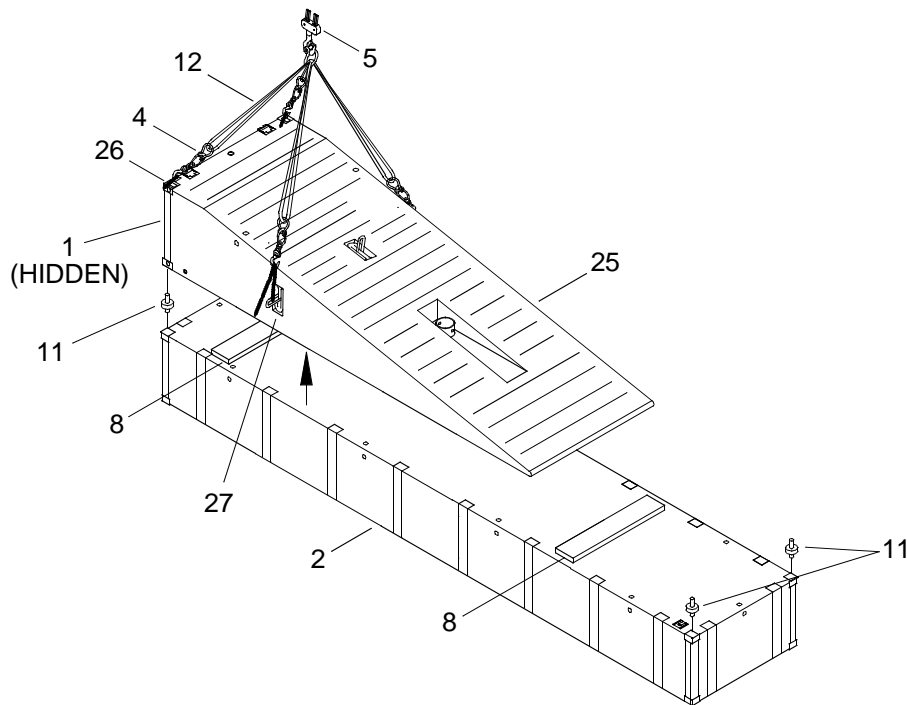
ASSEMBLE CAUSEWAY FERRY BEACH END (CFBE) MODULE ISOPAK

1. Verify drain plugs (1) on center module (2) are installed.



2. Attach two 53,000 lb slings (3) and two 36,000 lb adjustable chain slings (4) from crane (5) to padeyes (6) on center module (2).
3. Using slings (3 and 4) and crane (5), lift center module (2) into position for assembly.
4. Remove two 36,000 lb adjustable chain slings (4) from padeyes (6) on center module (2).
5. Remove two 53,000 lb slings (3) from crane (5).
6. Install four vertical connectors (11) and dunnage (8) on center module (2).

7. Verify drain plugs (1) on CFBE module (25) are installed.
8. Attach four 8,400 lb slings (12) and four 36,000 lb adjustable chain slings (4) to two corners (26) and two side padeyes (27) on CFBE module (25).



WARNING



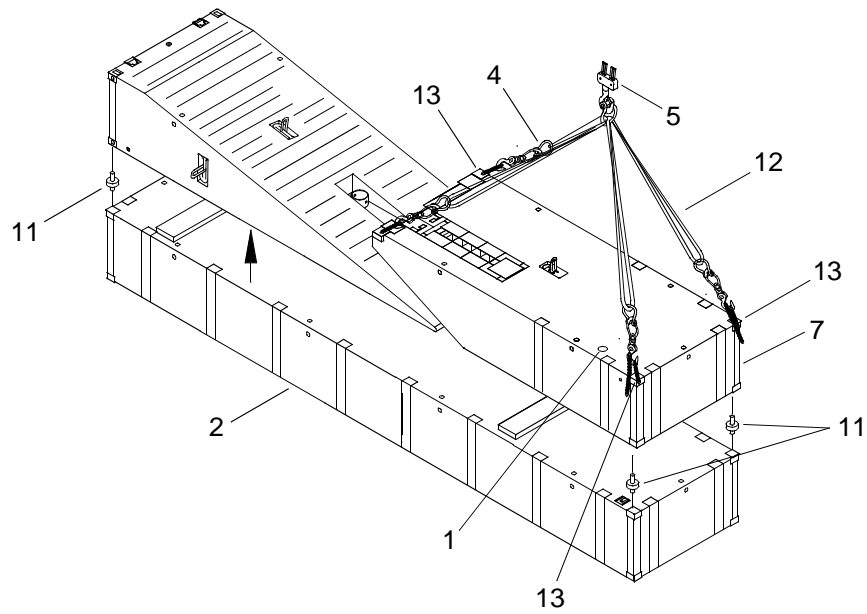
HEAVY PARTS

9. Using slings (12 and 4) and crane (5), lift CFBE module (25) into position on two vertical connectors (11) on center module (2).
10. Lock two vertical connectors (11) by rotating levers (16).
11. Using ladder, climb on top of module (2).
12. Remove four 8,400 lb slings (12) and four 36,000 lb adjustable chain slings (4) to two corners (26) and two side padeyes (27) on CFBE module (25).
13. Verify drain plugs (1) on end rake modules (7) are installed.
14. Descend from top of module (2) and remove ladder.

NOTE

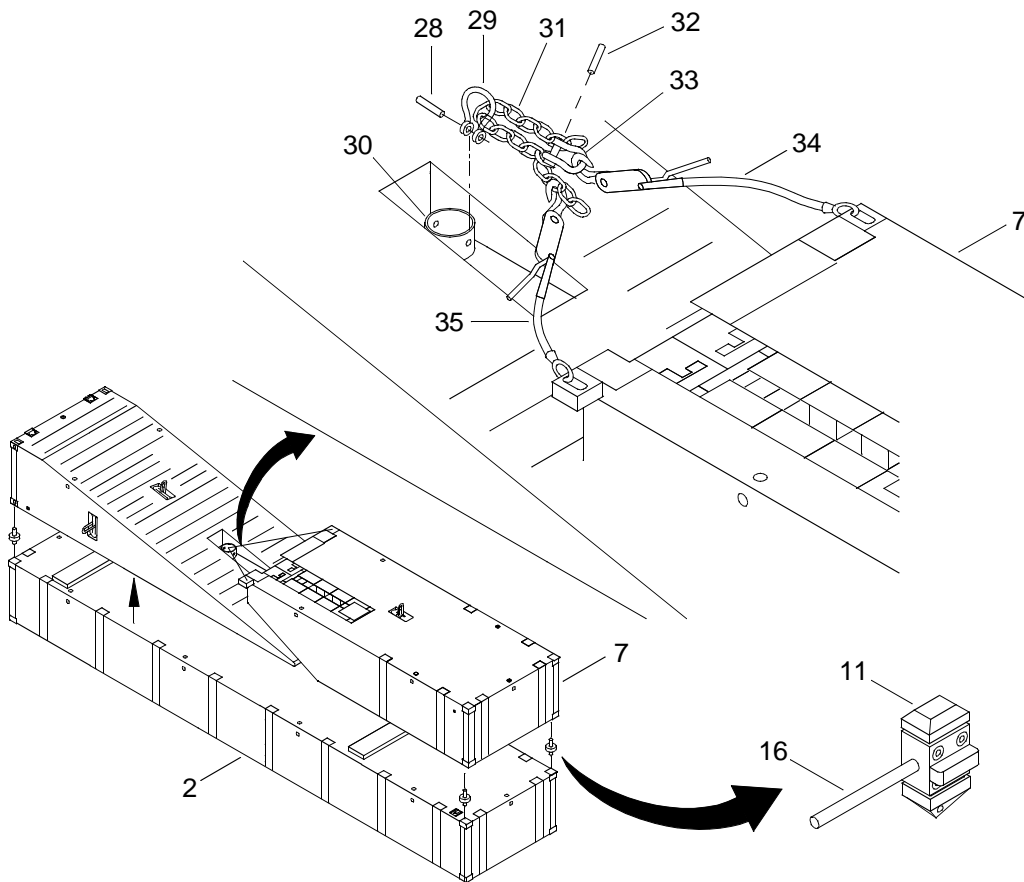
Either a left, right or center end rake may be mounted on the center module with a CFBE.

15. Attach four 8,400 lb slings (12) and four 36,000 lb adjustable chain slings (4) from crane (5) to corners (13) on end rake module (7).



16. Using slings (12 and 4) and crane (5), lift and position end rake module (7) on two vertical connectors (11) on center module (2).

17. Lock two vertical connectors (11) by rotating levers (16).



18. Using ladder, climb on top of modules.

19. Remove pin (28) from shackle (29).
20. Install shackle (29) on rhino horn fitting (30).
21. Install pin (28) through rhino horn fitting (30) and shackle (29).
22. Install chain (31) through shackle (29).
23. Remove pin (32) from shackle (33).
24. Install shackle (33) on chain (31).
25. Install pin (32) in shackle (33).
26. Install tie down cable (34) between end rake (7) and shackle (33).
27. Install tie down cable (35) between end rake (7) and chain (31).
28. Tighten and secure tie down cables (34 and 35).
29. Descend from top of assembled module ISOPAK and remove ladder.

END OF WORK PACKAGE

**OPERATOR MAINTENANCE
CAUSEWAY FERRY
OPERATION UNDER UNUSUAL CONDITIONS**

INITIAL SETUP:**Tools**

Gloves, Men's and Women's (Leather Palm) (Item 31, WP 0105 00)
 Goggles, Sun, Wind and Dust (Safety) (Item 34, WP 0105 00)
 Life Preserver, Vest (Item 45, WP 0105 00)
 Helmet, Safety (Brown) (Item 40, WP 0105 00)

Personnel Required

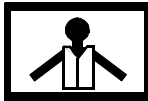
Seaman 88K

References

FM 3-4
 FM 3-5

NUCLEAR, BIOLOGICAL OR CHEMICAL DECONTAMINATION

WARNING



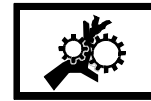
VEST



HELMET PROTECTION



HEAVY PARTS



MOVING PARTS

All personnel must wear personal flotation device, hard hat, safety shoes and gloves during CF operations and maintenance. Failure to observe these precautions could result in serious injury or death.

In the event equipment has been exposed to Nuclear, Biological or Chemical warfare, the equipment shall be handled with extreme caution and decontaminated in accordance with FM 3-5, titled "NBC Decontamination". Unprotected personnel can experience injury or death if residual toxic agents or radioactive material are present. If equipment is exposed to radioactive, biological or chemical agents, personnel must wear protective mask, hood, protective overgarments, chemical gloves and chemical boots in accordance with MOPP level prescribed by the OIC or NCOIC. MOPP analysis and levels are described in detail in FM 3-4, titled "NBC Protection". Personnel should contact a Class A Army vessel which has the capabilities for fresh water washdown. The Class A Vessel can also assist in the evacuation of soldiers who have been exposed and provide space and shelter for exchanging MOPP suits.

1. Decontaminate equipment per FM 3-5.
2. Perform operational check of all equipment after decontamination.

END OF WORK PACKAGE

**OPERATOR MAINTENANCE
CAUSEWAY FERRY
OPERATION UNDER UNUSUAL CONDITIONS**

INITIAL SETUP:**Personnel Required**Seaman 88K

UNUSUAL ENVIRONMENT/WEATHER

WARNING

It is critical for safety purposes to keep the engine hatch covers closed when engines are running, except when engine maintenance is being performed. Failure to do so can result in personal injury.

1. During extreme heat, perform the following steps.
 - a. Keep engine coolant at proper level.
 - b. Do not fill the fuel tank above full mark. Allow room for expansion of fuel.
 - c. Increase battery PMCS. Keep electrolytes to proper level.
 - d. Verify engine exhaust fans are on to keep engine room compartment temperature from rising above 20° ambient.

CAUTION

Follow drainage procedures for raw water system, as required, in daily PMCS during below freezing weather conditions 32°F. Failure to do so will result in severe damage to the system.

2. During extreme cold, perform the following steps.
 - a. Inspect water discharge outlets, connectors, deck, deck fittings, hatch latches and any other areas or components that may have operational or safety factors affected by ice buildup.
 - b. Check bilge pumps frequently for operation. If necessary, use hot air or hot water to thaw pumps.
 - c. Keep engine coolant mixture at proper mixture to prevent freeze up.
3. When operating the CF in salt water, perform the following steps.
 - a. Always keep hatch covers closed.
 - b. If available, wash down engines and accessories with fresh water. Wipe dry the exteriors of engines and engine accessories after each operation.
 - c. Keep below deck compartments as dry as possible.

- d. Check frequently for signs of corrosion wherever surfaces are exposed to salt water and air exposure.
 - {1} Check above deck lights, portable fire extinguisher, topside equipment and electrical components/connections.
 - {2} Check below deck lights, fire suppression system, engine and electrical components/connections
 - {3} Wipe items frequently to remove excess moisture accumulation.
 - {4} Repair corroded areas as soon as possible.
4. In the event the CF must be operated with only one engine, perform the following steps.
 - a. Adjust steering procedures to prevent turning.
 - b. Report the problem and return to shore as soon as possible for repairs.
5. In the event the CF loses power to both engines, perform the following steps.
 - a. Deploy the anchor to avoid drifting. (WP 0034 00)
 - b. Radio for emergency help.
6. In the event the weather conditions rise above SEA STATE condition 2, perform the following steps.
 - a. Proceed with caution to a safe harbor.
 - b. If movement is not possible, deploy anchorboard assembly and abandon the CF until sea conditions improve. (WP 0034 00)

END OF WORK PACKAGE

**OPERATOR MAINTENANCE
CAUSEWAY FERRY
EMERGENCY STARTING PROCEDURES
OPERATION UNDER UNUSUAL CONDITIONS**

INITIAL SETUP:

Tools

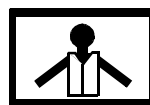
- Gloves, Men's and Women's (Leather Palm) (Item 31, WP 0105 00)
- Goggles, Sun, Wind and Dust (Safety) (Item 34, WP 0105 00)
- Life Preserver, Vest (Item 45, WP 0105 00)
- Helmet, Safety (Brown) (Item 40, WP 0105 00)

Personnel Required

Seaman 88K

EMERGENCY PROCEDURES- EMERGENCY STARTING OF THE ENGINE

WARNING



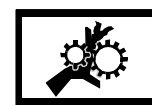
VEST



HELMET PROTECTION



HEAVY PARTS



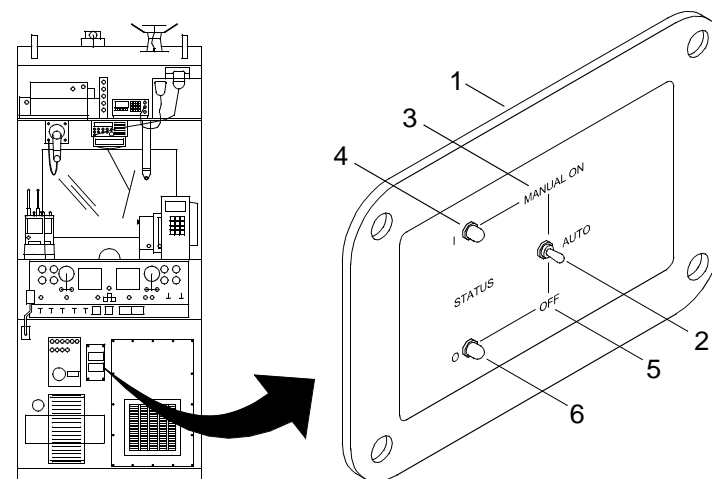
MOVING PARTS

All personnel must wear personal flotation device, hard hat, safety shoes and gloves during CF operations and maintenance. Failure to observe these precautions could result in serious injury or death.

NOTE

If engines will not start, the remote control battery selector switch can parallel all batteries together to provide maximum power for starting. The remote control battery selector switch also provides status of the multi-battery isolator.

1. Using the remote control panel (1), manually position toggle switch (2) to the MANUAL ON position (3) to parallel batteries.



2. Hold toggle switch (2) in the MANUAL ON position (3) until MANUAL ON green indicator (4) illuminates. If green indicator (4) does not illuminate, contact unit maintenance.

-
3. Release toggle switch (2).
 4. Start engines. (WP 0020 00)
 5. Position toggle switch (1) in "O" (off position) (5) to disable the remote control battery selector switch (1).
 6. Verify yellow disabled light (6) illuminates on remote control battery selector switch (1). If the yellow disable light (6) does not illuminate, contact unit maintenance.

END OF WORK PACKAGE

**OPERATOR MANUALS
GENERAL PAGES
EMERGENCY RELEASE PROCEDURES
OPERATOR TRAINING CONDITIONS**

PERIODIC REVIEW

Notes

- *Class: Men's and Women's Locker Room (Class 01, WP-00110)*
- *Subject: Men's and Women's Locker Room (Class 01, WP-00110)*
- *End Procedure: None (Class 01, WP-00110)*
- *Release: Safety (Release Class 01, WP-00110)*

Personnel Required

None (00)

References

None (000000)

EMERGENCY RELEASE PROCEDURES RELATED TO CLASSICAL PAGES

Illustration



TOILET



RELIEF PAPERING USE



RELIEF PAPER



RELIEF PAPER

All personnel must wear personal flotation device, headlamp, safety glasses and gloves during JLF operations and maintenance. Failure to observe these procedures could result in serious injury or death.

NOTE

All equipment remaining from Alaska State Troop Cooperation (ASTC) exercises may be used as an auxiliary power source for starting power.

1. Check and service batteries prior to storage/return (WP-00110-001-01)

1. Remove the front cover of the front cover of the front cover.



1. Align chamfered edge of mounting component with (1).



1. CHAMFER

2. Remove mounting screws from front cover with (2) and install component (1).



2. REMOVE

3. Connect one end of front cover cable to the front cover.

4. Insert front cover cable through projection inside of mounting component with (3) using below tool.

5. Connect front cover cable to a front cover cable.

6. Test signal. (REF:08100000)

DECLASSIFIED



ELECTRONIC

- 10. Remove K&B's data entries by from K&B's computer file on P&S.

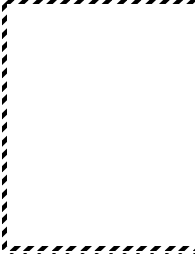
DECLASSIFIED



ELECTRONIC

- 10. Remove K&B's data entries by from CP and disseminate those given names.
- 11. Give geographic details of military component task file.
- 12. Search computer records on K&B's data table file and P&S file computer file.
- 13. Monitor mobile communications communications for binary change (CP/WH/BB).
- 14. When full binary change is indicated, check data copies (CP/WH/BB).

END OF WORK PRODUCT



**OPERATOR MAINTENANCE
CAUSEWAY FERRY
DIESEL ENGINE
OPERATION UNDER UNUSUAL CONDITIONS**

INITIAL SETUP:**Personnel Required**Seaman 88K

EMERGENCY PROCEDURE - EMERGENCY SHUTDOWN OF THE ENGINE

WARNING

It is critical for safety purposes to keep the engine hatch covers closed when engines are running, except when engine maintenance is being performed. Failure to do so can result in personal injury.

CAUTION

Emergency shutdown should be used only when the engine does not respond to the normal stopping procedure. Use of emergency shutdown can cause lubricating oil to be sucked past the oil seals and into the blower housing and/or cause damage to the turbocharger.

To ensure positive closure should another emergency shutdown be required, the shutdown must be checked and required repairs or adjustments made. Failure to comply may permit engine run-on when the emergency shutdown is activated.

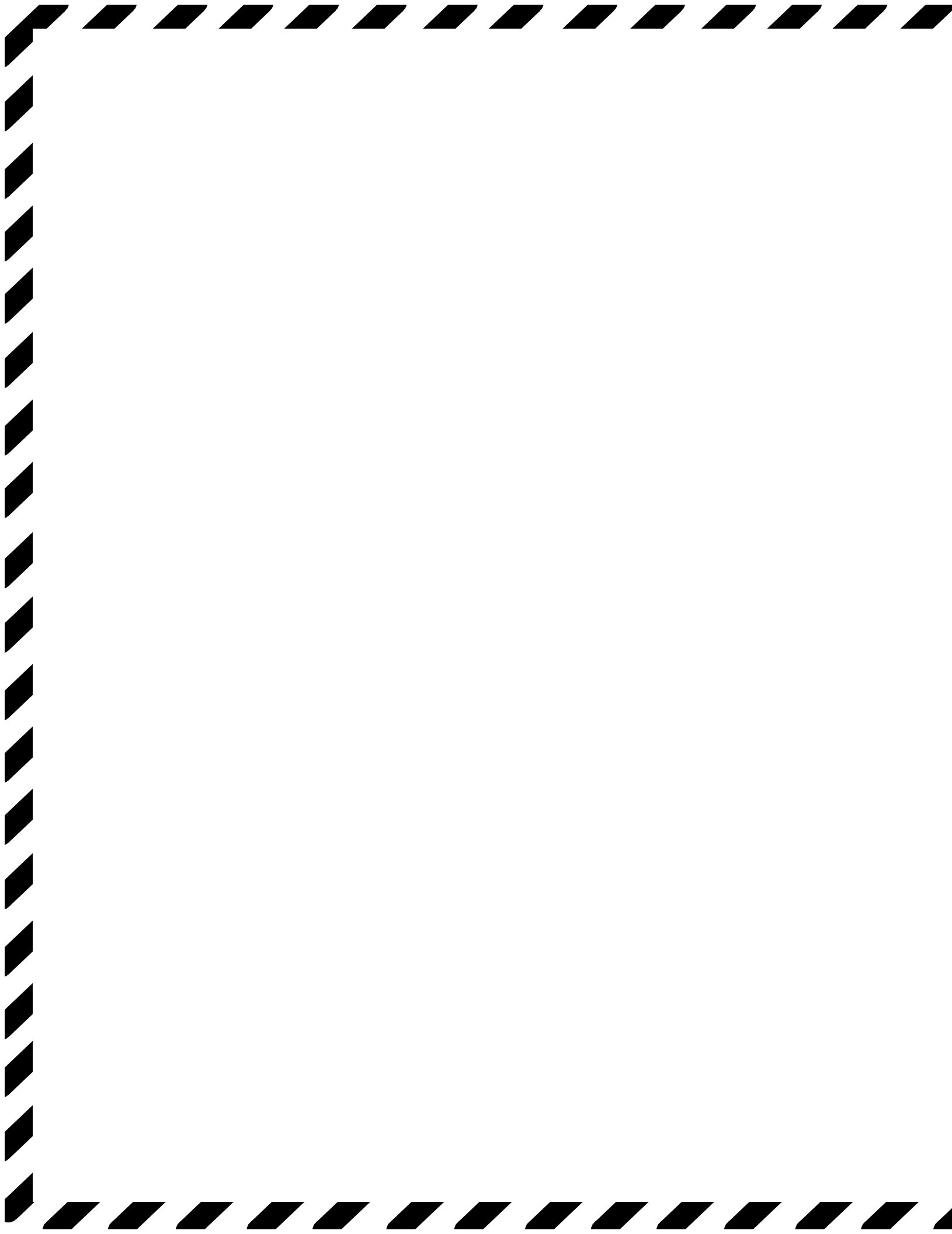
NOTE

The engine emergency stop is automatic when the fire suppression system is actuated or on an overspeed condition.

The air manifold intake flapper door must be manually reset by moving reset lever downward when normal conditions resume.

1. Press the EMERGENCY STOP button. (WP 0006 00)
2. After the emergency shutdown, contact unit maintenance to check for engine damage and proper operation before the CF is returned to service.
3. Reset the air shutdown, located in the air inlet housing. (WP 0006 00)

END OF WORK PACKAGE



**OPERATOR MAINTENANCE
CAUSEWAY FERRY
FIRE SUPPRESSION SYSTEM
OPERATION UNDER UNUSUAL CONDITIONS**

INITIAL SETUP:**Tools**

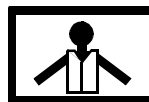
Tool Kit, General Mechanic's (Rail and Marine) (Item 76, WP 0105 00)
Gloves, Men's and Women's (Leather Palm) (Item 31, WP 0105 00)
Goggles, Sun, Wind and Dust (Safety) (Item 34, WP 0105 00)
Life Preserver, Vest (Item 45, WP 0105 00)
Helmet, Safety (Brown) (Item 40, WP 0105 00)

Personnel Required

Seaman 88K

EMERGENCY PROCEDURE - MANUALLY OPERATE THE FIRE SUPPRESSION SYSTEM**ACTIVATE FIRE SUPPRESSION FROM ABOVE DECK**

WARNING



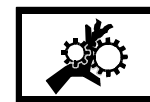
VEST



HELMET PROTECTION



HEAVY PARTS



MOVING PARTS

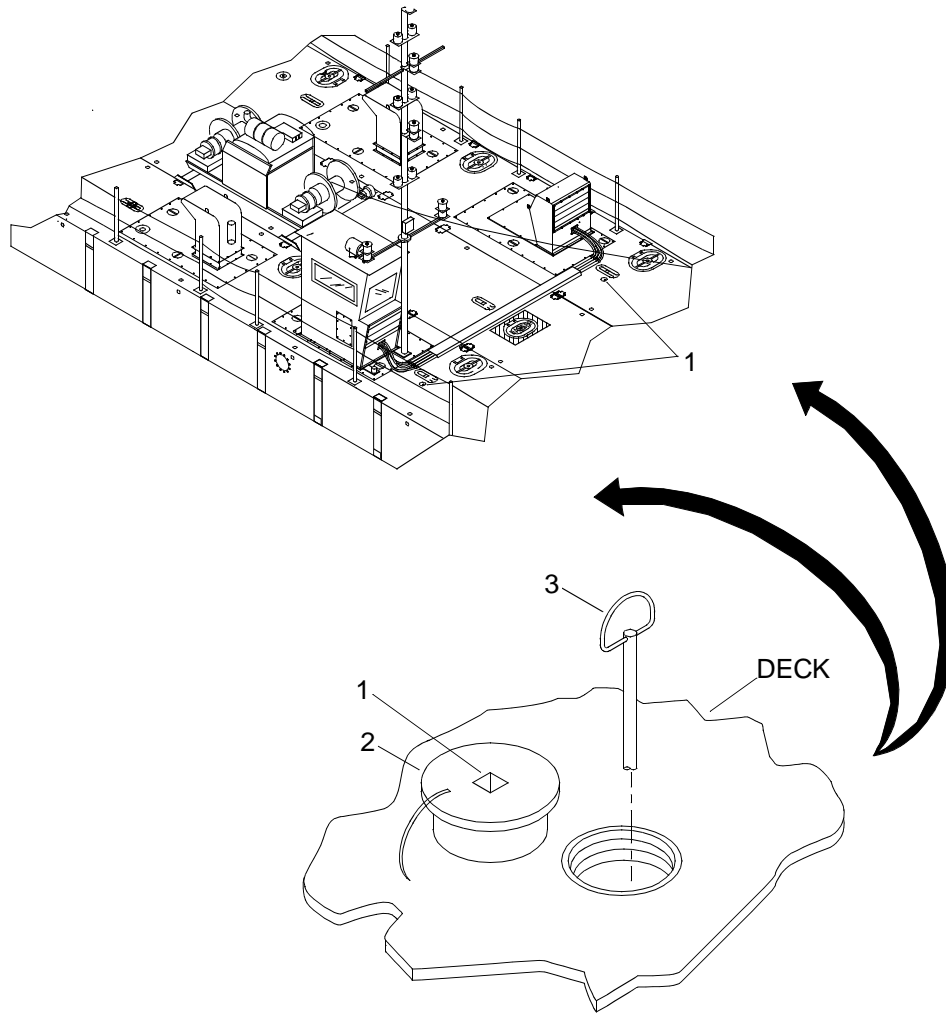
All personnel must wear personal flotation device, hard hat, safety shoes and gloves during CF operations and maintenance. Failure to observe these precautions could result in serious injury or death.

CO2 reduces the available oxygen in the atmosphere and will not support life. Accidental discharge of this agent can cause serious injury or death to personnel.

NOTE

In case of fire, activate the fire suppression system and/or use the hand operated fire extinguisher.

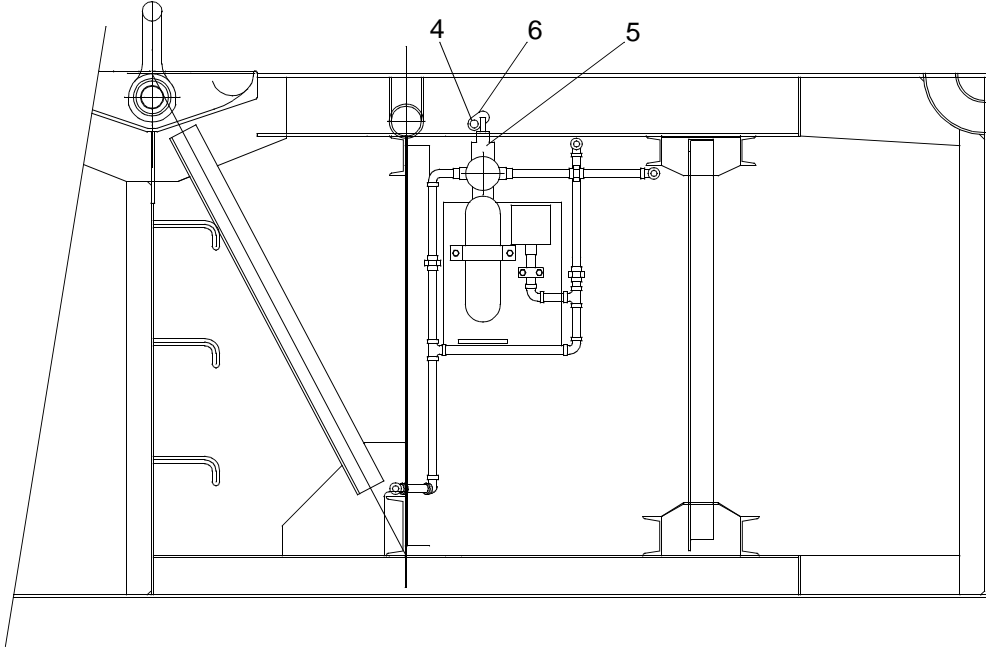
1. Remove spanner wrench from operators cab.



2. Insert spanner wrench into fitting (1).
3. Turn flush deck watertight hatch (2) counterclockwise and remove.
4. Pull D-ring (3) to activate CO2 system.

ACTIVATE FIRE SUPPRESSION SYSTEM FROM TIME DELAY CYLINDER

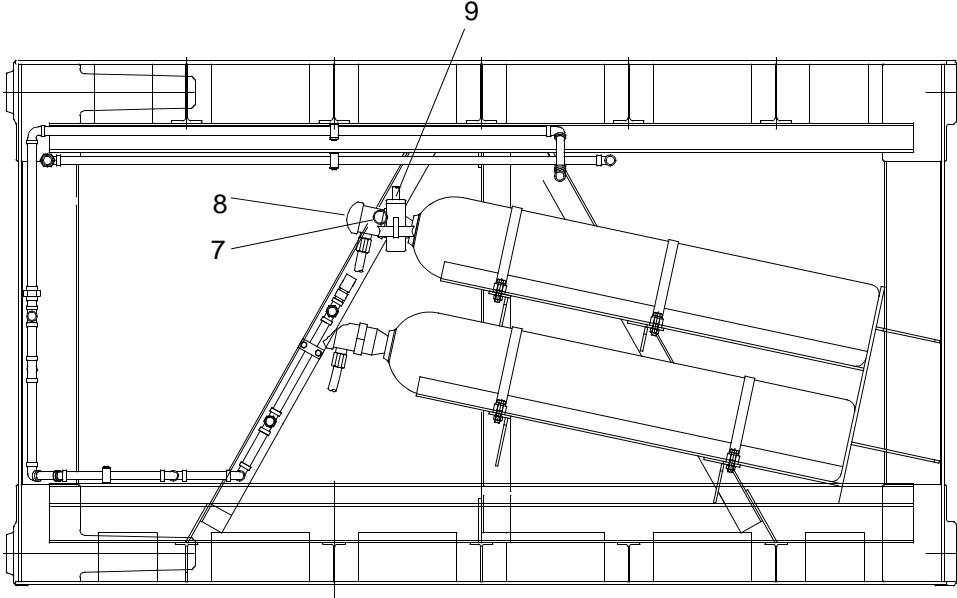
- 1. Pull pin (4) from time delay cylinder (5).



- 2. Pull lever (6) to actuate fire suppression system.

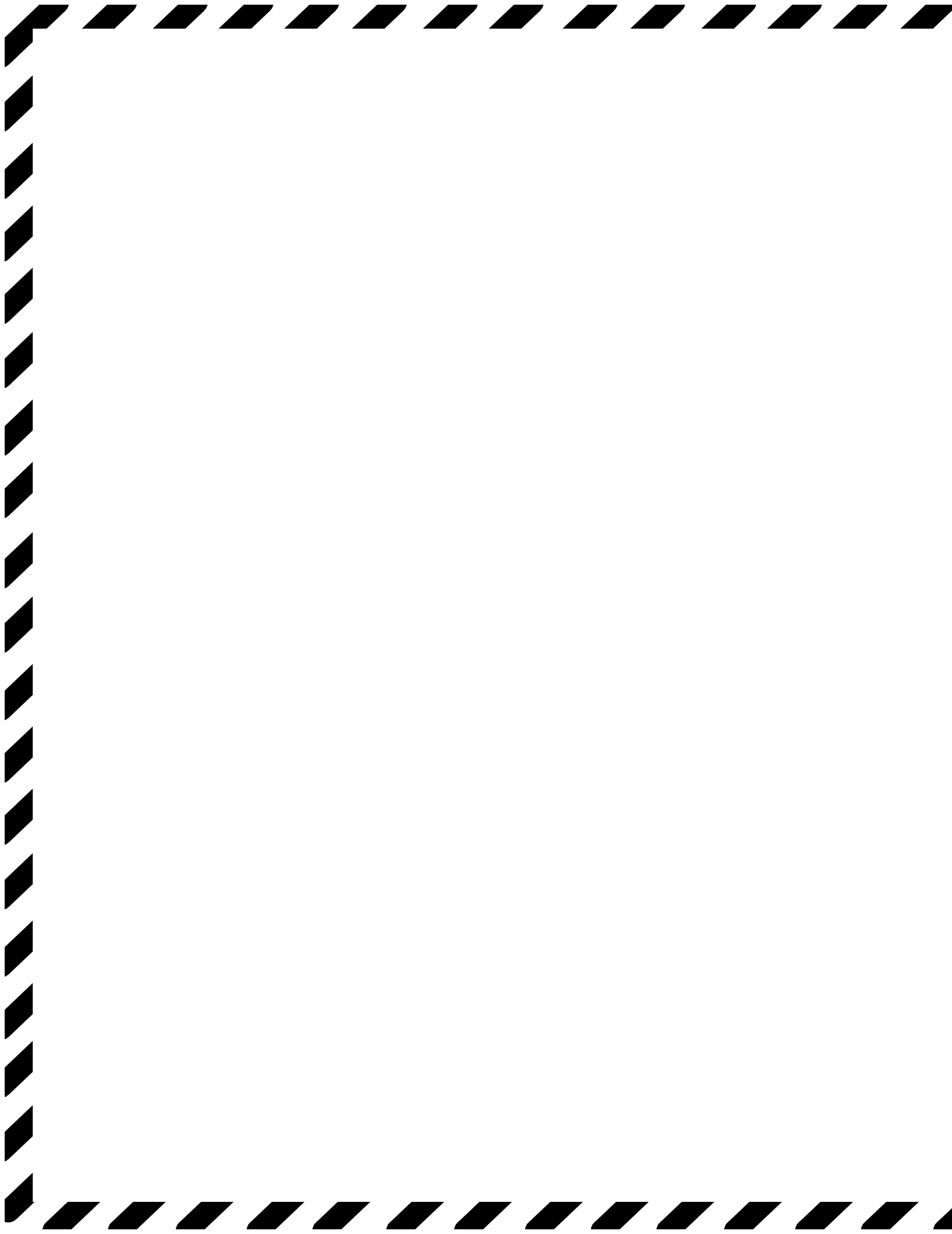
ACTIVATE FIRE SUPPRESSION SYSTEM FROM CO2 CYLINDER

- 1. Pull pin (7) from CO2 cylinder (8).



- 2. Pull lever (9) to actuate fire suppression system.

END OF WORK PACKAGE



**OPERATOR MAINTENANCE
CAUSEWAY FERRY
STEERING SYSTEM
OPERATION UNDER UNUSUAL CONDITION**

INITIAL SETUP:**Tools**

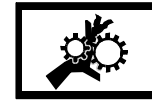
Tool Kit, General Mechanic's (Rail and Marine) (Item 76, WP 0105 00)
Gloves, Men's and Women's (Leather Palm) (Item 31, WP 0105 00)
Goggles, Sun, Wind and Dust (Safety) (Item 34, WP 0105 00)
Life Preserver, Vest (Item 45, WP 0105 00)
Helmet, Safety (Brown) (Item 40, WP 0105 00)

Personnel Required

Seaman 88K

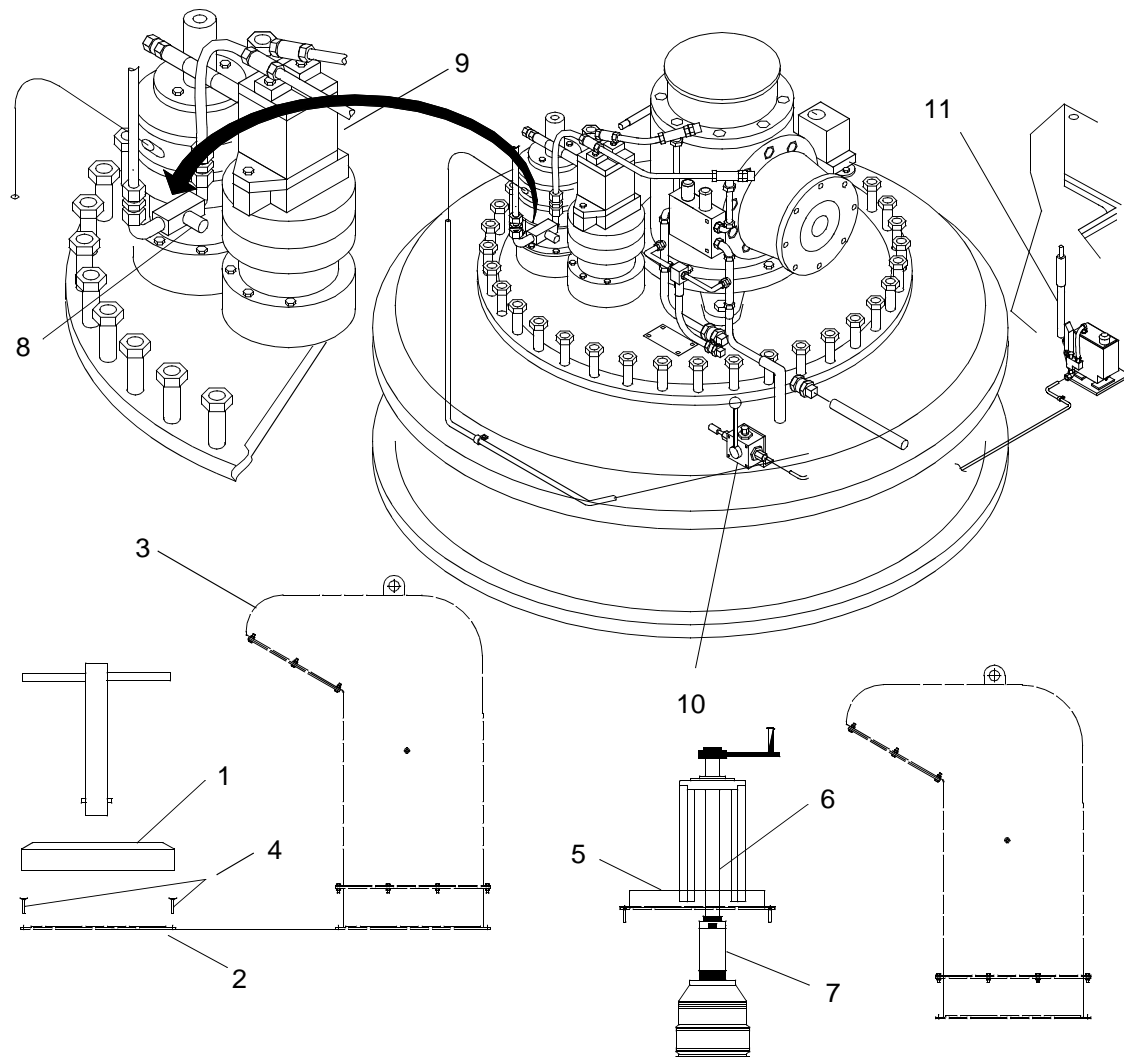
EMERGENCY PROCEDURE - EMERGENCY STEERING

WARNING

**VEST****HELMET PROTECTION****HEAVY PARTS****MOVING PARTS**

All personnel must wear personal flotation device, hard hat, safety shoes and gloves during CF operations and maintenance. Failure to observe these precautions could result in serious injury or death.

1. Remove emergency steering unit from the lazaret compartment (forward machinery hatch of propulsion module).
2. Remove emergency steering hatch cover (1) on propulsion module pump-jet thruster hatch (2) located aft of the exhaust plenum (3).



3. Remove three flat head screws (4) from the pump-jet thruster hatch (2).
4. Set support (5) on pump-jet thruster hatch (2) and install three flat head screws (4) through the slotted holes in the support (5). Do not tighten.
5. Install drive shaft (6) on hydraulic steering motor shaft (7).

- a. Align the drive shaft (6) with the steering motor shaft (7).

NOTE

Ensure that drive shaft (6) and steering motor shaft (7) are not binding.

- b. Check steering assembly for proper vertical alignment of the drive shaft (6) with the steering motor shaft (7).
6. Tighten three flat head screws (4) securing support (5) to pump-jet thruster hatch (2).

CAUTION

Do not attempt to operate steering hydraulically with needle valve closed and emergency steering shaft connected. Serious damage to gearbox, shaft or motor may result.

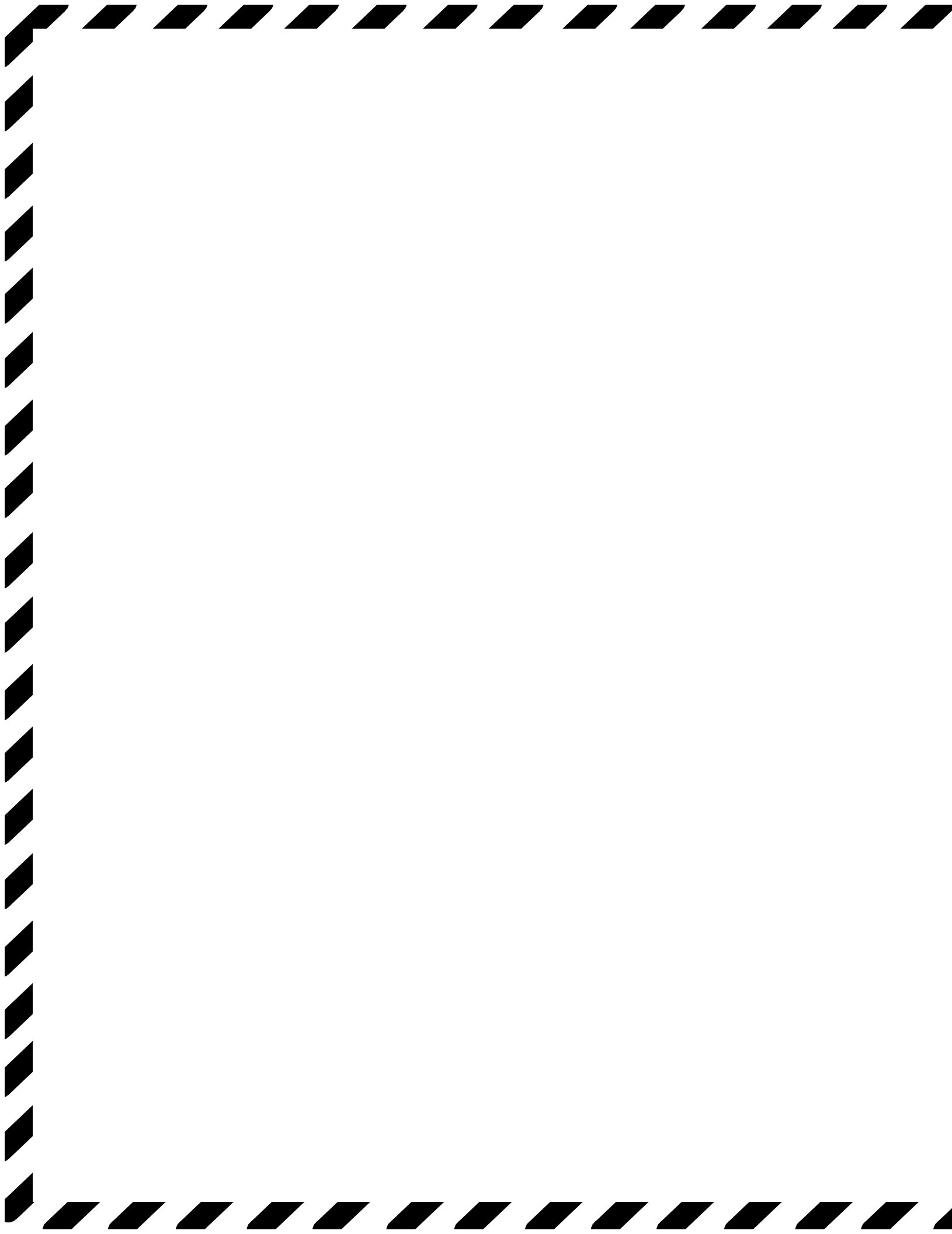
7. Open the emergency steering needle valve (8) on the hydraulic steering motor (9).
8. Turn 3/2 way-valve (10).
9. Release brake with hand pump (11).

NOTE

During emergency steering operation the operator in the operators cab will instruct the crewman operating the hand crank to turn the crank based on the thrust dial indicator reading.

10. Rotate the hand crank counterclockwise to move the pump-jet thruster nozzle and move the warping tug to the right.
11. Rotate the hand crank clockwise to move the pump-jet thruster nozzle and move the warping tug to the left.

END OF WORK PACKAGE



**OPERATOR MAINTENANCE
CAUSEWAY FERRY
STEERING SYSTEM
OPERATION UNDER UNUSUAL CONDITIONS**

INITIAL SETUP:

Tools

- Tool Kit, General Mechanic's (Rail and Marine) (Item 76, WP 0105 00)
- Gloves, Chemical (Item 29, WP 0105 00)
- Goggles, Industrial (Chipping, Chemical) (Item 32, WP 0105 00)

Personnel Required

Seaman 88K

Equipment Condition

Engine Shut Down. (WP 0020 00)

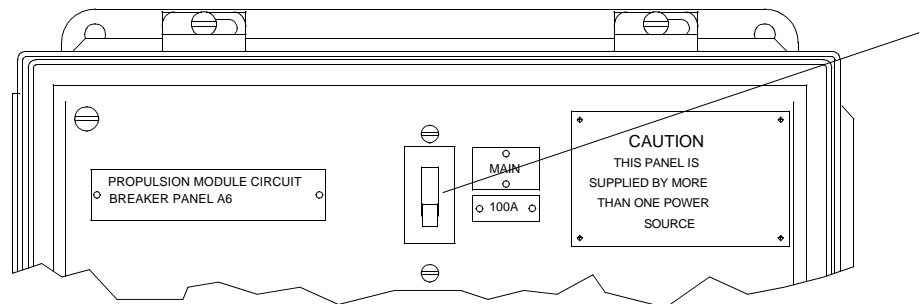
EMERGENCY PROCEDURE - EMERGENCY ENGAGEMENT OF MARINE GEAR

NOTE

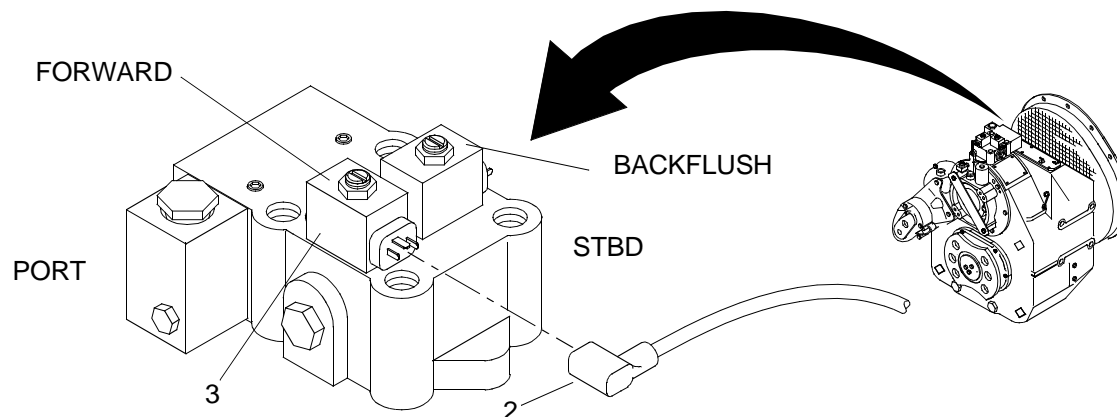
The following procedure is typical for the installation of the emergency lock-up plug used to lock the marine gear into the forward or backflush position.

After installation of the emergency lock-up plug, the lower control panel A2 PORT/STBD CLUTCH toggle switch will no longer control the marine gear. The marine gear will remain locked until the plug is removed.

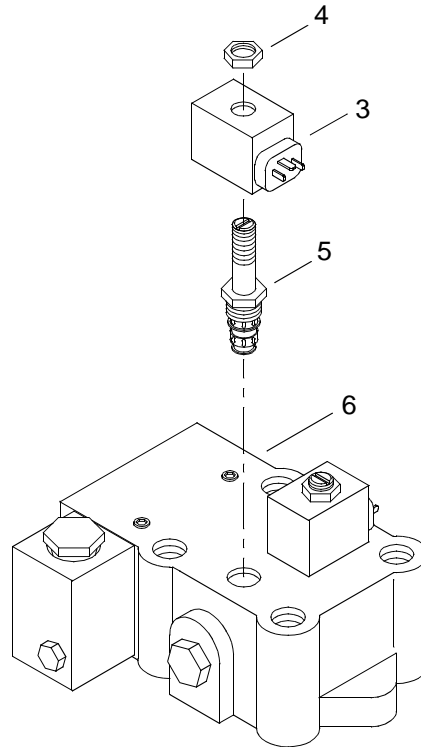
1. Verify MAIN circuit breaker (1) on propulsion module circuit breaker panel A6 is in off position.



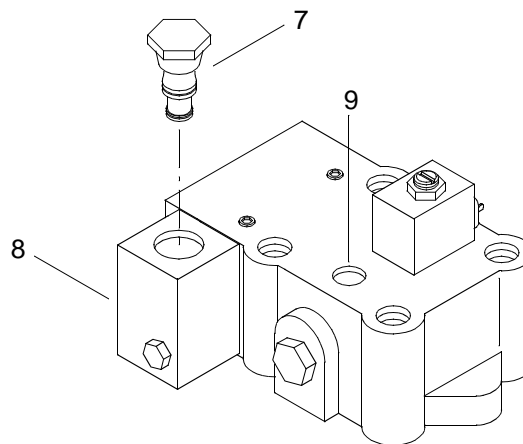
2. Disconnect electrical plug-in connection (2) from forward control valve solenoid (3).



3. Remove nut (4) and control valve solenoid (3) from control valve (5).



4. Remove the control valve assembly (5) from the control valve body (6).
5. Remove cavity plug (7) from plug carrier (8).



6. Install cavity plug (7) in port (9) vacated by control valve (5) and tighten plug (7).
7. Start engine. (WP 0020 00)
8. Upon completion of mission, contact unit maintenance for replacement of marine forward control valve solenoid (3).

END OF WORK PACKAGE

**OPERATOR MAINTENANCE
CAUSEWAY FERRY
PRECISION LIGHTWEIGHT GLOBAL POSITIONING RECEIVER (PLGR)
OPERATION UNDER UNUSUAL CONDITIONS**

INITIAL SETUP:**Tools**

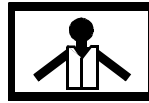
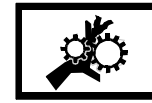
Gloves, Men's and Women's (Leather Palm) (Item 31, WP 0105 00)
Goggles, Sun, Wind and Dust (Safety) (Item 34, WP 0105 00)
Life Preserver, Vest (Item 45, WP 0105 00)
Helmet, Safety (Brown) (Item 40, WP 0105 00)

Personnel Required

Seaman 88K

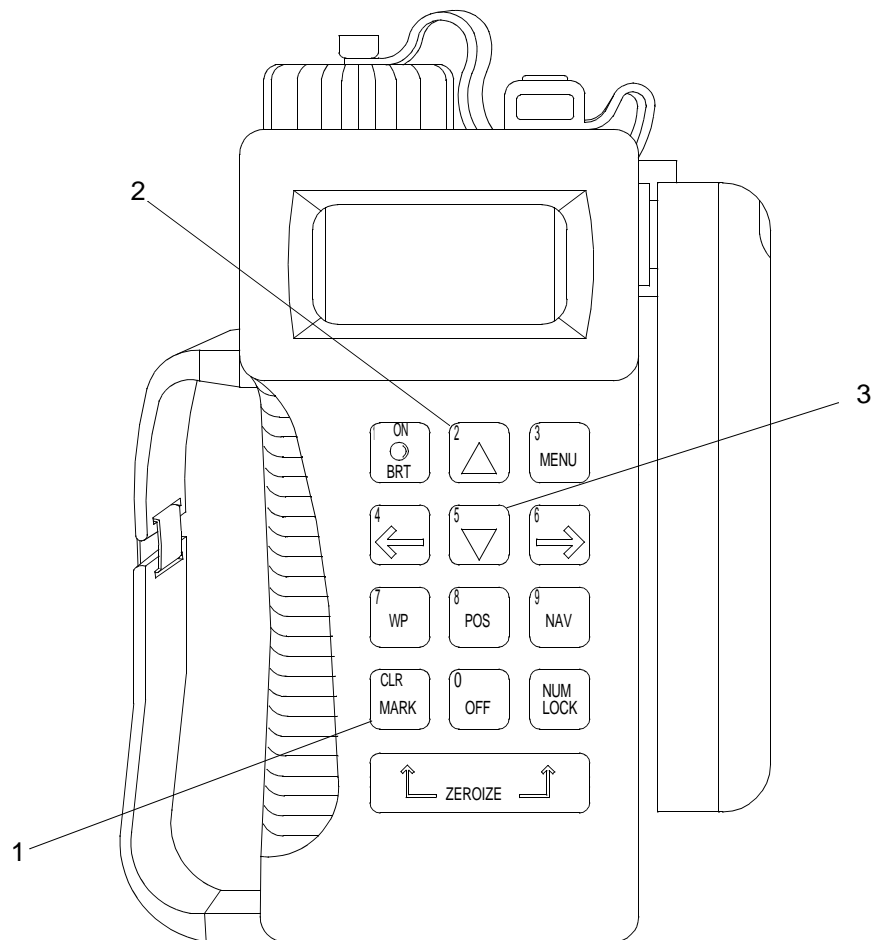
EMERGENCY PROCEDURE - MARK POSITION OF MAN OVERBOARD

WARNING

**VEST****HELMET PROTECTION****HEAVY PARTS****MOVING PARTS**

All personnel must wear personal flotation device, hard hat, safety shoes and gloves during CF operations and maintenance. Failure to observe these precautions could result in serious injury or death.

1. The man overboard selection is utilized using the MARK key (1). When notified that a man is overboard, immediately press the MARK key (1). Pressing the MARK key (1) freezes the current position.



- When the MARK key (1) is pressed the first time, the MARK POS display will appear. The waypoints field will be flashing. You may keep this waypoint number or assign a different designation using the UP ARROW key (2) or DOWN ARROW key (3).

```

MARK POS> WP : 005
MARK : saveas
NAV : ManOverbrd
ON : cancels
  
```

- If a waypoint number is chosen that already exists, OVERWRITES will appear on the display.
- To store the man overboard information, press the MARK key (1) again.
- Navigate to the man overboard marked position to rescue the man overboard.

```

WP 005      MOB005
RNG         0.2yds
AZ  360.0° T
↓ to return
  
```

END OF WORK PACKAGE

**OPERATOR MAINTENANCE
CAUSEWAY FERRY
VHF/FM DSC TRANSCEIVER
OPERATION UNDER UNUSUAL CONDITIONS**

INITIAL SETUP:

Tools

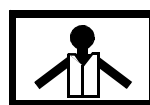
- Gloves, Men's and Women's (Leather Palm) (Item 31, WP 0105 00)
- Goggles, Sun, Wind and Dust (Safety) (Item 34, WP 0105 00)
- Life Preserver, Vest (Item 45, WP 0105 00)
- Helmet, Safety (Brown) (Item 40, WP 0105 00)

Personnel Required

Seaman 88K

EMERGENCY PROCEDURE - SEND DISTRESS USING VHF/FM DSC TRANSCEIVER

WARNING



VEST



HELMET PROTECTION



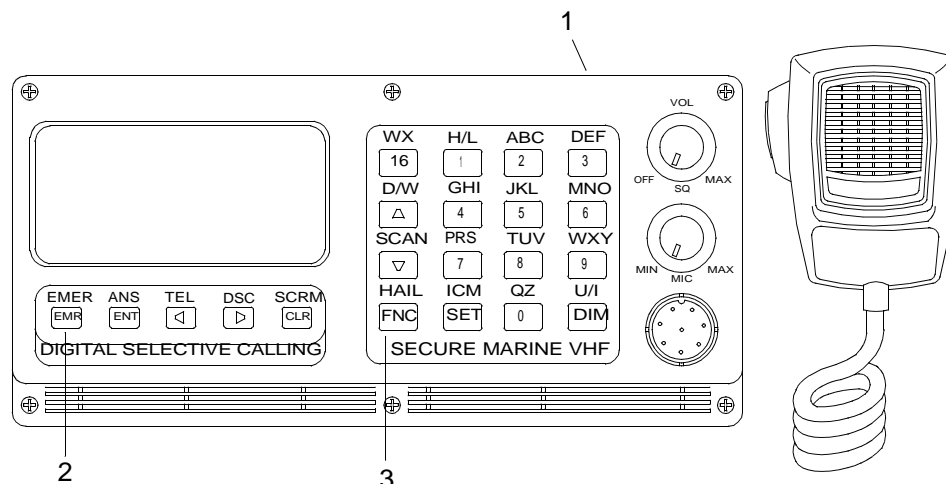
HEAVY PARTS



MOVING PARTS

All personnel must wear personal flotation device, hard hat, safety shoes and gloves during CF operations and maintenance. Failure to observe these precautions could result in serious injury or death.

1. The EMERGENCY mode may be used to send a distress call. The distress call automatically includes the vessel's DSC call sign and LAT/LON position. The vessel's position can be sent only if the PLGR is operational.
2. To access the EMERGENCY functions of the VHF/FM DSC transceiver (1) press the EMR key (2) or press the FNC key (3) and the EMR key (2).

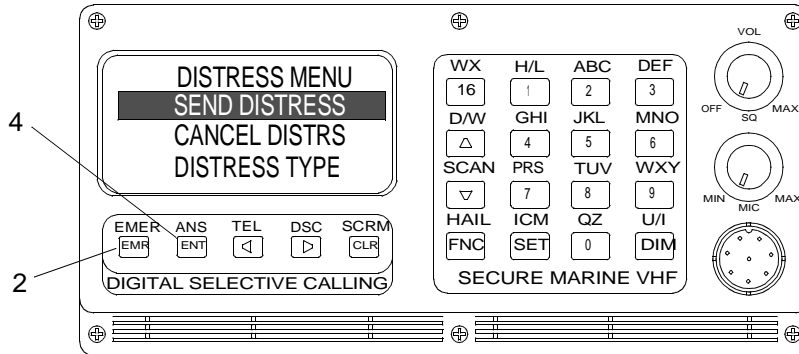


SEND DISTRESS

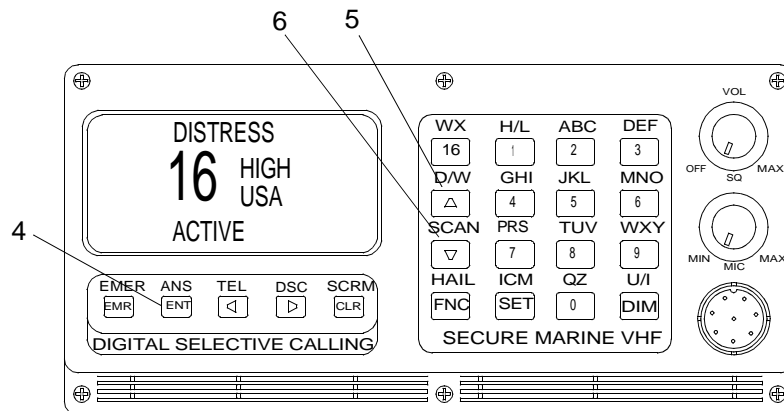
- To access and send a distress call, first go to the DISTRESS MENU by pressing the EMR key (2).

NOTE

The menu selection by default is the "send distress" option.



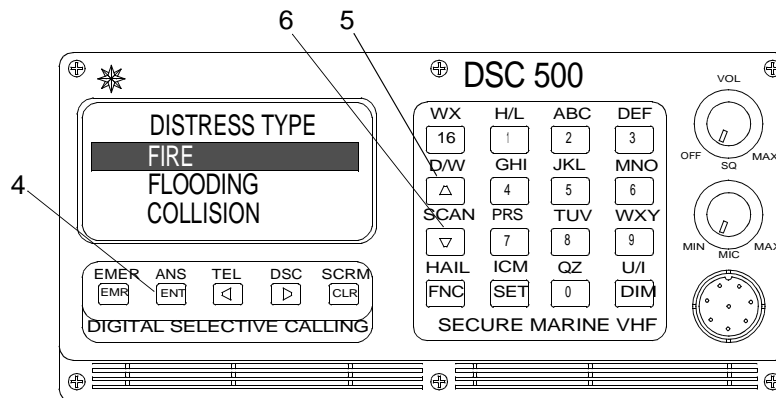
- From the DISTRESS MENU, press and hold the EMR key (2) or the ENT key (4). The display prompts the user to HOLD KEY TO SEND DISTRESS and has a countdown indicator on the bottom line displaying the number of seconds until transmission of the distress call. The EMR key (2) or the ENT key (4) must be held for 5 seconds before the DISTRESS CALL will be transmitted. If the key is released before the distress call is sent, the transmit timer will restart at 5 seconds.



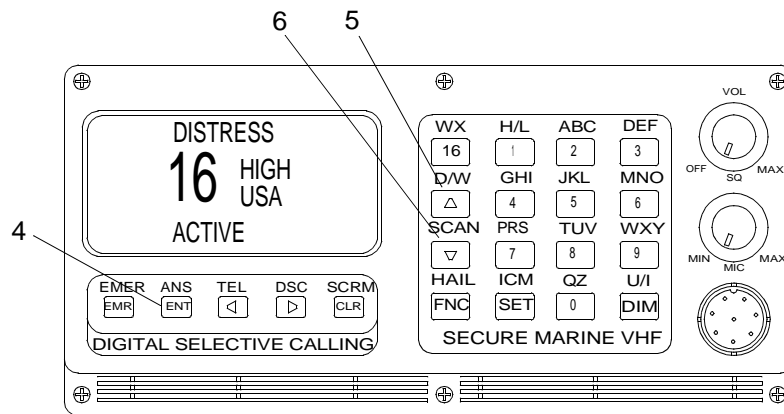
- To specify the type of distress, select the DISTRESS TYPE menu option with the UP ARROW key (5) or DOWN ARROW key (6) and press the ENT key (4). The menu options are:

FIRE
FLOODING
COLLISION
GROUNDING
CAPSIZING+
SINKING
ADRIFT
UNDESIGNATED (default if none selected)
ABANDONING
PIRACY
MAN OVERBOARD

- Select the type of distress with UP ARROW key (5) or DOWN ARROW key (6) and press the ENT key (4). The selected distress type will remain active until the radio is turned off.



- DISTRESS will appear in the upper line of the display and ACTIVE will appear in the lower line while waiting for an acknowledgement. If a DSC acknowledgement is not received from a shore station within two minutes, the distress call will be automatically repeated. If, after five minutes from the second call, a shore station has not acknowledged the distress call or cancelled by the sender, distress will be rebroadcast with an updated position. Distress will continue to be rebroadcast every five minutes until either acknowledged or cancelled. When acknowledgement is received, DISTRESS CALL ACKNOWLEDGEMENT PRESS ANY KEY will be displayed and the distress call will be automatically cancelled.



- a. Other functions of the transceiver may be used while the emergency mode is active.
 - b. As a reminder that the emergency mode is active, the distress tone will sound for five seconds every thirty seconds.
6. Select the LAT/LON ENTRY option from the main distress menu using the option from the main distress menu using the UP ARROW key (5) or DOWN ARROW key (6) and press the ENT key (4). If the transceiver has no position from the PLGR, the screen will be blank. Enter the latitude and longitude for the current position. To enter the hemisphere, press the corresponding key where the alpha character is located.

END OF WORK PACKAGE

**OPERATOR MAINTENANCE
CAUSEWAY FERRY
VHF/FM DSC TRANSCEIVER
OPERATION UNDER UNUSUAL CONDITIONS**

INITIAL SETUP:

Tools

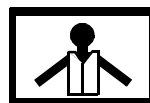
- Gloves, Men's and Women's (Leather Palm) (Item 31, WP 0105 00)
- Goggles, Sun, Wind and Dust (Safety) (Item 34, WP 0105 00)
- Life Preserver, Vest (Item 45, WP 0105 00)
- Helmet, Safety (Brown) (Item 40, WP 0105 00)

Personnel Required

Seaman 88K

EMERGENCY PROCEDURE - RECEIVING A DISTRESS

WARNING



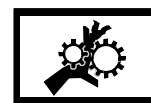
VEST



HELMET PROTECTION



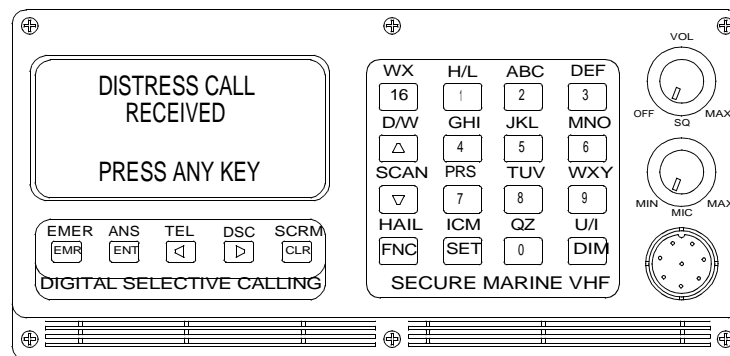
HEAVY PARTS



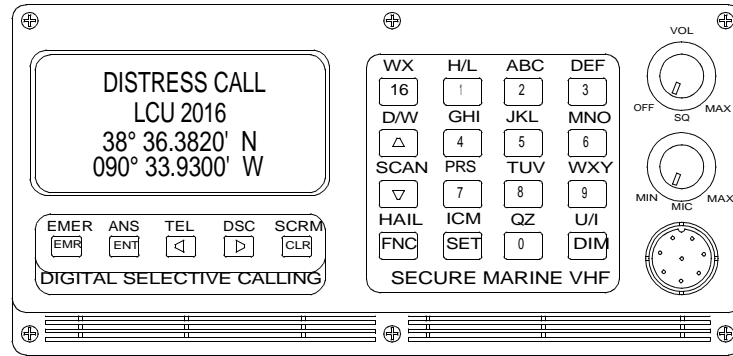
MOVING PARTS

All personnel must wear personal flotation device, hard hat, safety shoes and gloves during CF operations and maintenance. Failure to observe these precautions could result in serious injury or death.

1. When a distress is received, a distress tone will be heard on the radio. The transceiver will default to the distress display. Press any key.



- The vessel position and identification will appear in the transceiver display.

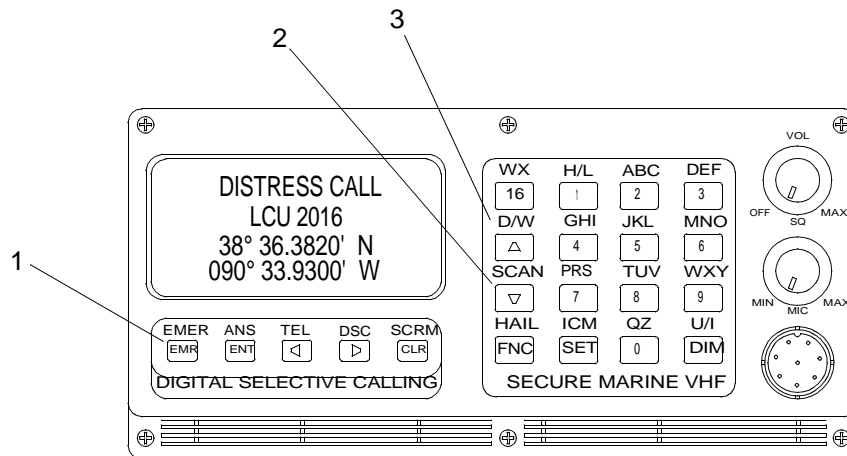


ACKNOWLEDGE DISTRESS

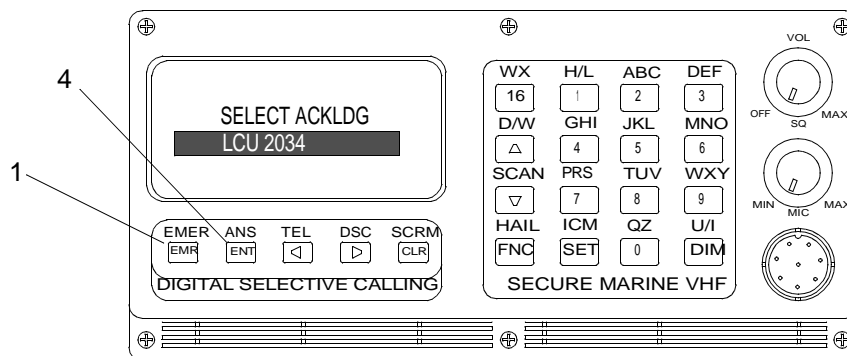
NOTE

A distress call cannot be acknowledged for the first 80 seconds after receiving the call. This allows time for shore base stations to respond to the distress call.

- Press the EMER key (1) to acknowledge a distress call that the transceiver has received. Select the DISTRESS ACK key option from the main distress menu with the UP ARROW key (2) or the DOWN ARROW key (3).

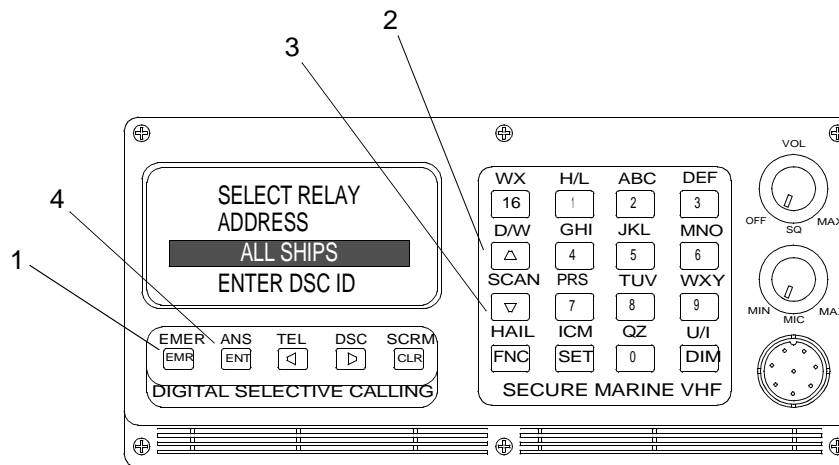


- Press the ENT key (4). The next display will be the DISTRESS LOG. Select the distress log entry which corresponds to the distress call that is to be acknowledged and press the ENT key (4).

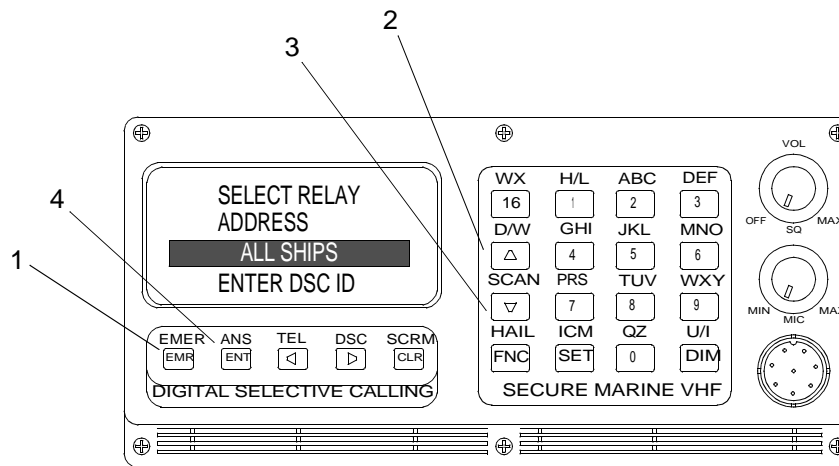


DISTRESS RELAY

1. Press the EMER key (1) to relay a distress call received by the transceiver. Select DISTRS RELAY from the main distress menu with the UP ARROW key (2) or the DOWN ARROW key (3) and press the ENT key (4). The distress log will be displayed. Select the distress log entry which corresponds to the distress call that is to be relayed. Press the ENT key (4).



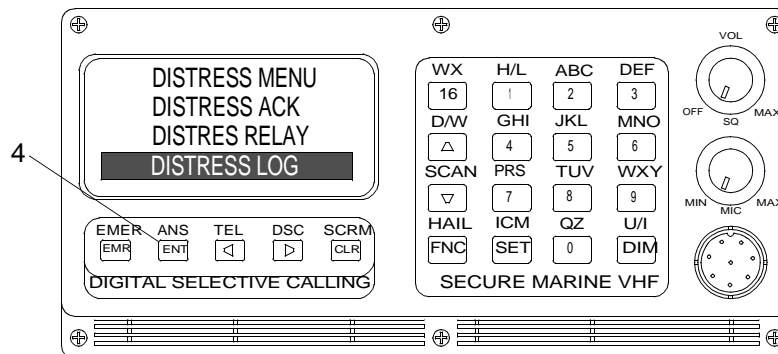
2. The next example is used to specify the destination of the relay distress call and contains the selection of either ALL SHIPS or DSC ID. The default is to ALL SHIPS and should be used if an official coast station's DSC ID is not known. With the ALL SHIPS option selected, press the ENT key (4) to send the distress relay.



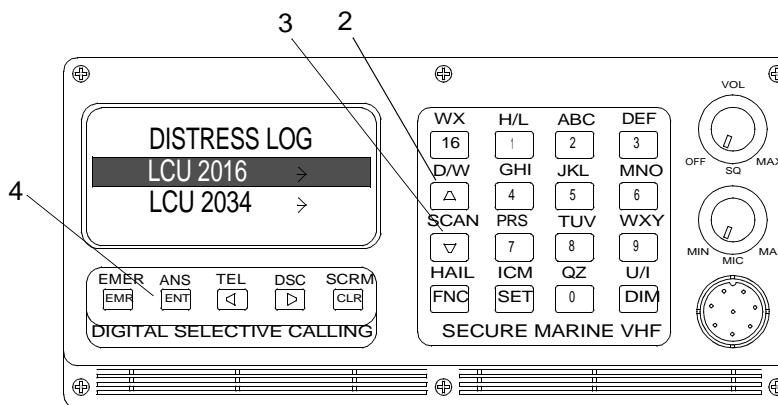
3. If the DSC ID of the coast station is known, select the DSC ID option. Press the ENT key (4). Enter the DSC ID key in the space provided. Press the ENT key (4) to send the distress relay.
4. The DISTRESS RELAY option is not available for distress calls that have already been acknowledged.

DISTRESS LOG

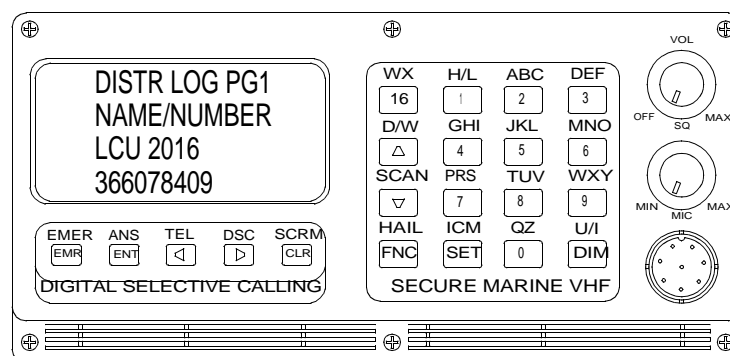
- The information and status of the last 20 distress calls received or generated is recorded in the distress log. The information is saved while the radio is turned off. To view the distress log, select the DISTRESS LOG from the main distress menu and press the ENT key (4).



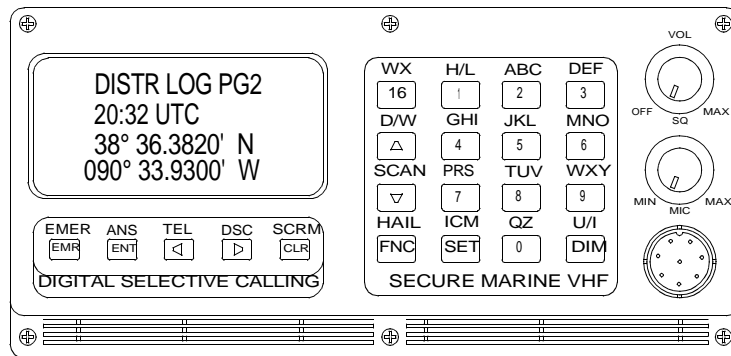
- The distress log directory displays a list of names or DSC number of the ENT key (4). Select a name or number from the log using the UP ARROW key (2) or the DOWN ARROW key (3). To select, press the ENT key (4). Once selected, use the RIGHT ARROW key (2) to move through the rest of the distress log pages.



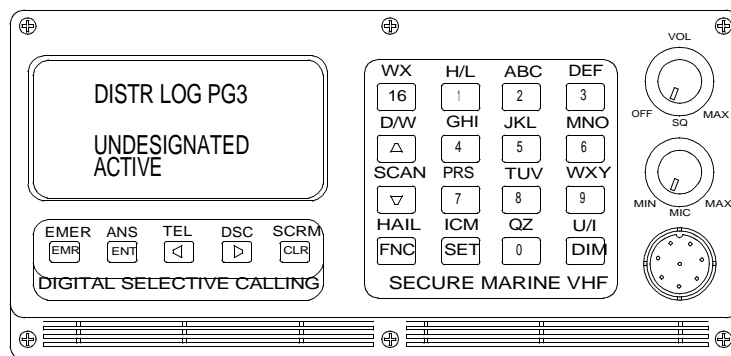
- Distress log page 1 displays the name and DSC ID number of the vessel that sent the distress call. If there is no name associated with the DSC ID (not in DSC directory), then this page is not available.



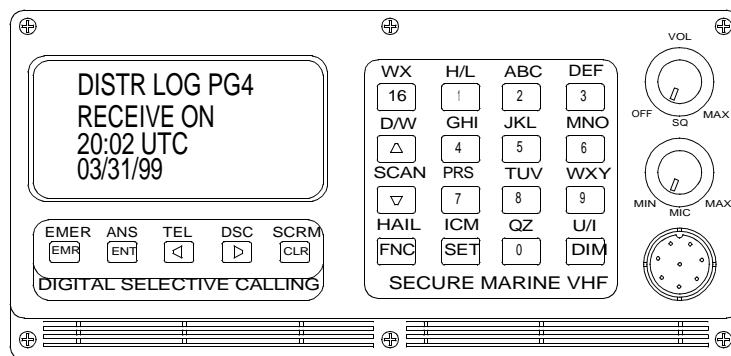
4. Distress log page 2 displays the latitude, longitude and time of position as received from the distress call.



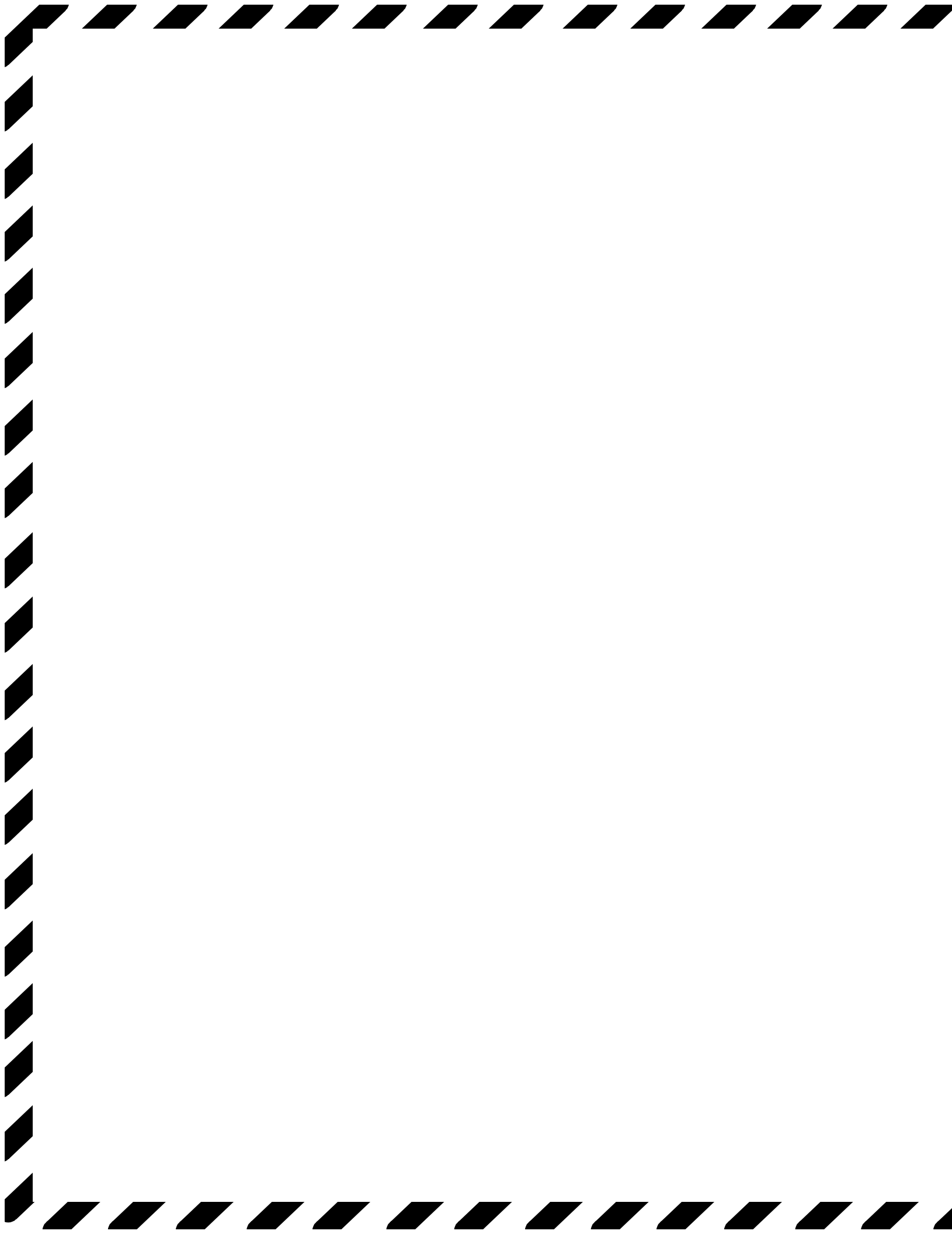
5. Distress log page 3 displays the status and other information about the distress call. If provided, the Number of People is displayed on line 2. The type of distress is displayed on line 3 and the status of the call is displayed on line 4. The status can be one of the following: Active, Relay, Acknowledged and Cancelled.



6. Distress log page 4 can only be accessed if the distress call has been acknowledged. This page displays the name and DSC ID number of the station that acknowledged the distress call.



END OF WORK PACKAGE



**OPERATOR MAINTENANCE
CAUSEWAY FERRY
VHF/FM DSC TRANSCEIVER
OPERATION UNDER UNUSUAL CONDITIONS**

INITIAL SETUP:

Tools

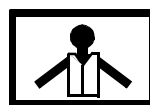
- Gloves, Men's and Women's (Leather Palm) (Item 31, WP 0105 00)
- Goggles, Sun, Wind and Dust (Safety) (Item 34, WP 0105 00)
- Life Preserver, Vest (Item 45, WP 0105 00)
- Helmet, Safety (Brown) (Item 40, WP 0105 00)

Personnel Required

Seaman 88K

EMERGENCY PROCEDURE - CANCEL DISTRESS USING THE VHF/FM DSC TRANSCEIVER

WARNING



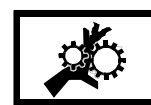
VEST



HELMET PROTECTION



HEAVY PARTS

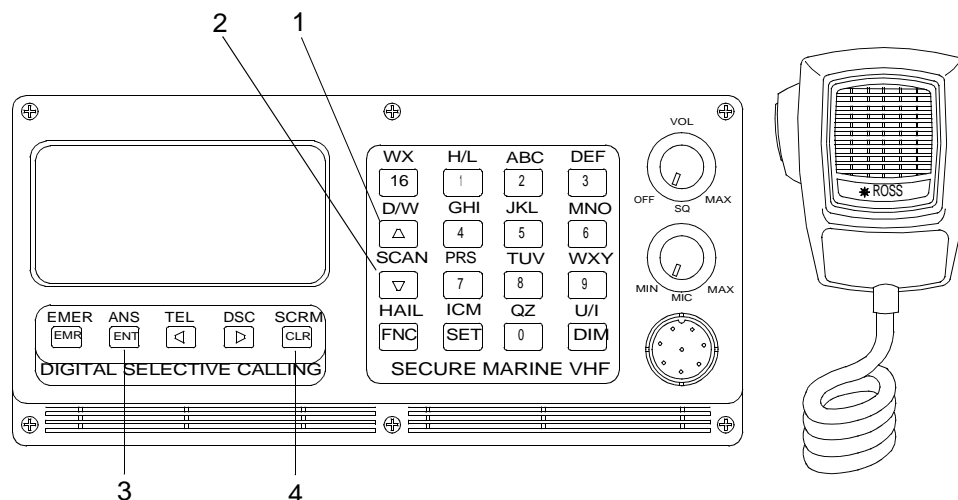


MOVING PARTS

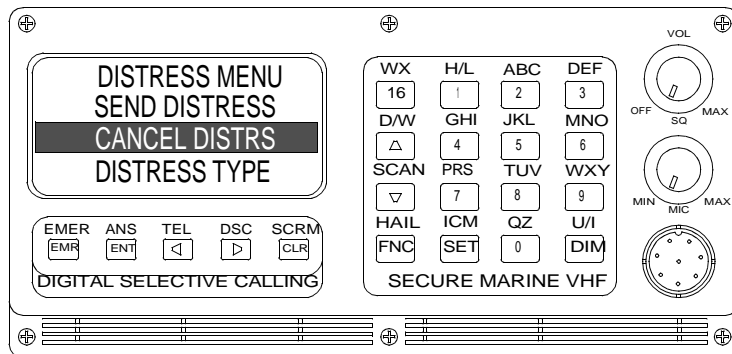
All personnel must wear personal flotation device, hard hat, safety shoes and gloves during CF operations and maintenance. Failure to observe these precautions could result in serious injury or death.

NOTE

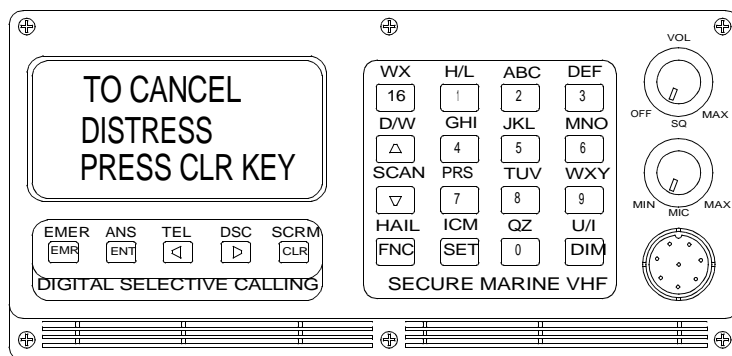
If a distress call is made by mistake, the CANCEL DISTRESS function can be used to cancel the active distress.



1. Use the UP ARROW key (1) or DOWN ARROW key (2) to select CANCEL DISTRS and press the ENT key (3).



2. Press the CLR key (4) to cancel the distress. This function is not available if there is not an active distress being transmitted. The CANCEL DISTRESS function sends out a DISTRESS ACKNOWLEDGEMENT with the DSC ID as the source and destination.



3. Tune the transceiver to the channel that the distress was transmitted on.
4. Broadcast cancellation message to ALL STATIONS with the required information.

VHF/FM message example:

All Stations, All Stations, All Stations
 This is NAME (vessel) CALL SIGN,
 DSC NUMBER, POSITION.
 Cancel my distress alert of
 DATE, TIME UTC,
 = Master NAME, CALL SIGN,
 DSC NUMBER, DATE, TIME UTC.

END OF WORK PACKAGE

**OPERATOR MAINTENANCE
CAUSEWAY FERRY
PUBLIC ADDRESS SET (LOUDHAILER)
OPERATION UNDER UNUSUAL CONDITIONS**

INITIAL SETUP:

Tools

- Gloves, Men's and Women's (Leather Palm) (Item 31, WP 0105 00)
- Goggles, Sun, Wind and Dust (Safety) (Item 34, WP 0105 00)
- Life Preserver, Vest (Item 45, WP 0105 00)
- Helmet, Safety (Brown) (Item 40, WP 0105 00)

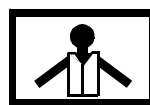
Personnel Required

Seaman 88K

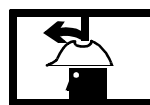
EMERGENCY PROCEDURE - PUBLIC ADDRESS SET (LOUDHAILER) EMERGENCY OPERATION

OPERATE FOG HORN AFTER RUNNING AGROUND IN FOG

WARNING



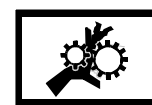
VEST



HELMET PROTECTION



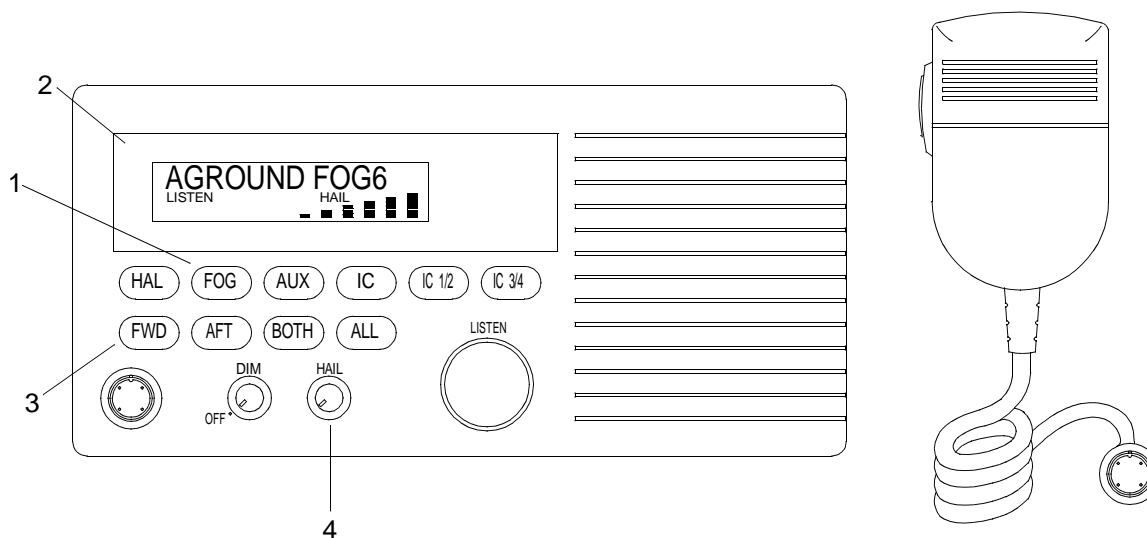
HEAVY PARTS

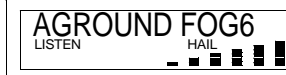


MOVING PARTS

All personnel must wear personal flotation device, hard hat, safety shoes and gloves during CF operations and maintenance. Failure to observe these precautions could result in serious injury or death.

1. Press the FOG key (1) repeatedly until AGROUND FOG6 appears in the LCD display (2).





2. Press the FWD speaker key (3) to select the forward speaker. FWD will appear in the LCD display speaker station window (2).



3. Adjust the HAIL volume knob (4) to the desired sound level.

END OF WORK PACKAGE

**OPERATOR MAINTENANCE
CAUSEWAY FERRY
BASIC ISSUE ITEMS (BII) AND EQUIPMENT
STOWAGE**

INTRODUCTION

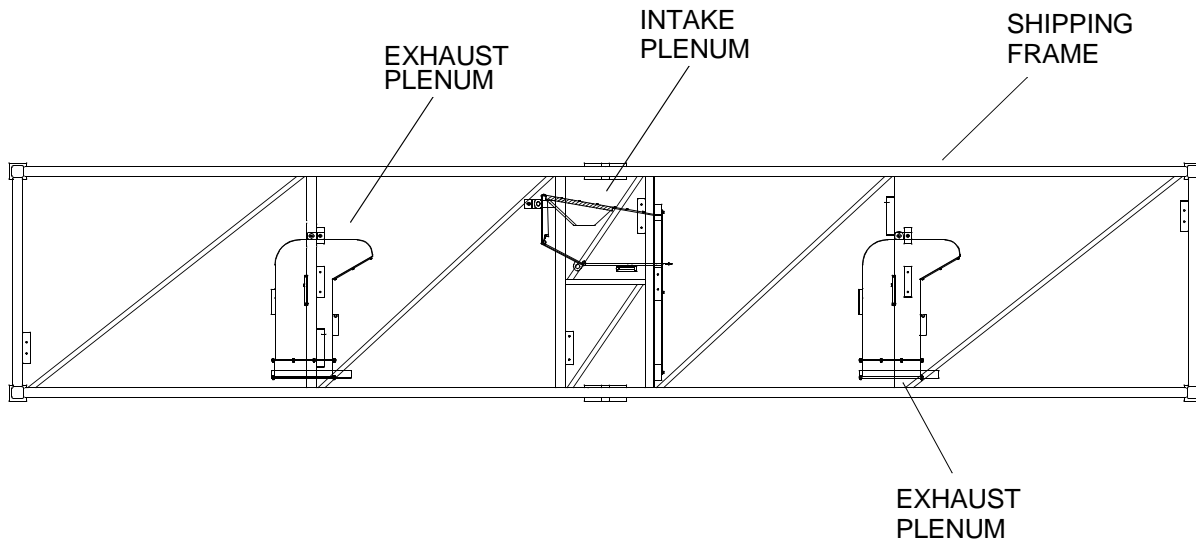
Scope

This work package covers stowage of the BII and equipment.

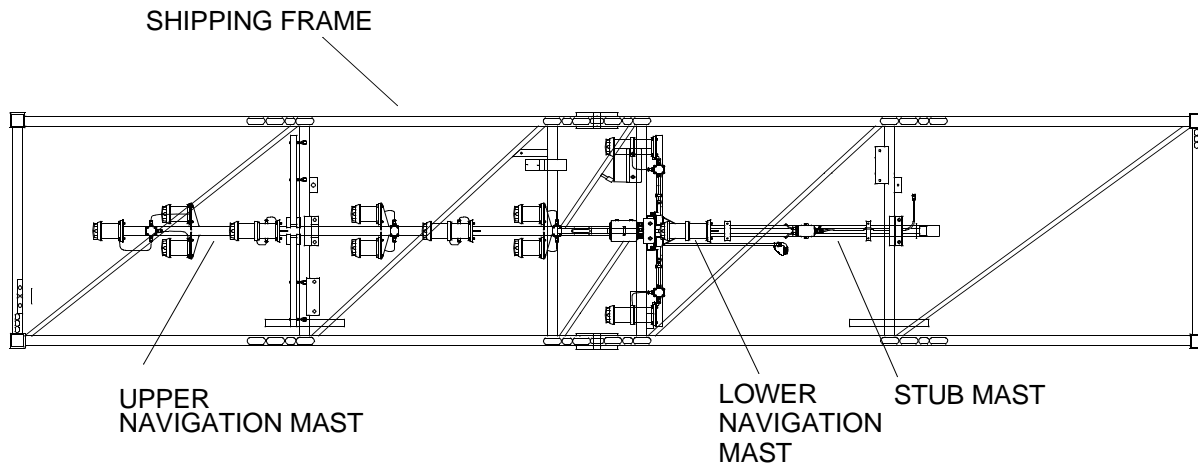
Stowage of BII

The components of the causeway ferry are stowed for transport and storage on pallets, in shipping frames and in the Basic Issue Items (BII) container. One shipping frame, containing the mast assembly sections, is shipped with two end rakes. A second shipping frame, containing the air intake plenum and exhaust plenums, is shipped with two end rakes. An empty shipping frame is shipped with each of the propulsion modules. The remainder of the causeway ferry components are stowed on pallets, as illustrated below.

STOWAGE OF PLENUMS



STOWAGE OF MAIN AND STUB NAVIGATION MASTS



STOWAGE OF BII

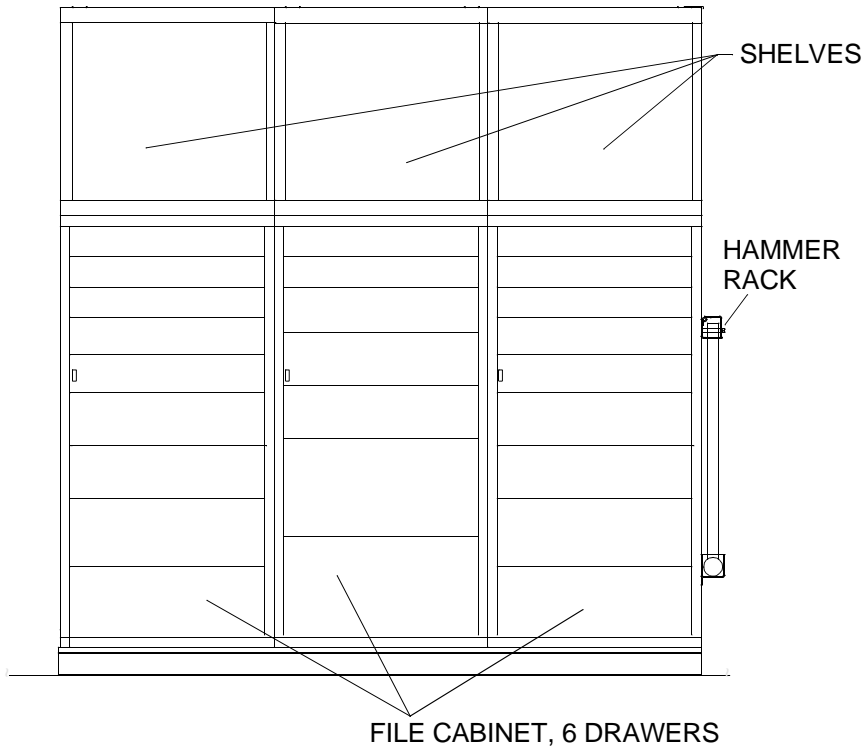
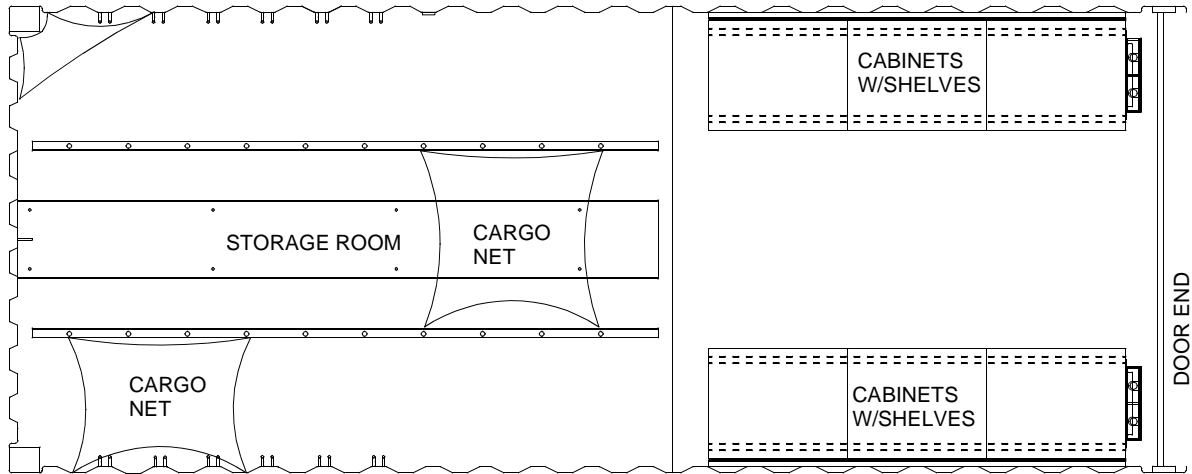


Table 1. BII Stowage Location.

DESCRIPTION	QTY	LOCATION
Apron, Utility	2	Cabinets
Ax, Pickhead	1	Storage Room on Hooks
Bar, Wrecking	2	Storage Room
Batteries, 6 Volt (Cases)	6	Storage Room and Cabinets
Batteries, D Size (Cases)	2	Storage Room and Cabinets
Blanket, Fire (72 in. x 60 in.)	1	Storage Room
Block, Snatch (8 in. Diameter)	4	Storage Room
Body Assembly Lantern (Clear Lens)	3	Storage Room
Body Assembly Lantern (Red Lens)	1	Storage Room
Bracket, Lantern	3	Storage Room
Chain Sling, Adjustable, 36,000 lbs	4	Storage Room
Crowbar	2	Storage Room
Extinguisher, Fire (15 lb)	3	Storage Room
Faceshield, Industrial	6	Cabinets
Fiber Rope Assembly, Single Leg (100 ft)	2	Storage Room
Fid (12 in.)	2	Storage Room
Flag, Signal ("A" INTL CODE SIZE 6)	1	Cabinets
Flag, Signal ("B" INTL CODE SIZE 6)	1	Cabinets
Flag, Signal ("O" INTL CODE SIZE 6)	1	Cabinets
Flag, Signal ("U" INTL CODE SIZE 6)	1	Cabinets
Flag, Signal ("V" INTL CODE SIZE 6)	1	Cabinets
Flag, Signal ("W" INTL CODE SIZE 6)	1	Cabinets
Flag, Signal ("Y" INTL CODE SIZE 6)	1	Cabinets
Flashlight	2	Cabinets
FLOCS with pump and hoses	1	Storage Room
Gloves, Antiflash	6	Cabinets
Gloves, Chemical	2	Cabinets
Gloves, Electric	6	Cabinets
Gloves, Men's and Women's (Leather Palm)	6	Cabinets
Goggles, Industrial (Chipping)	6	Cabinets
Goggles, Industrial (No Vents)	2	Cabinets

Table 1. BII Stowage Location. (Continued)

DESCRIPTION	QTY	LOCATION
Goggles, Sun, Wind and Dust	6	Cabinets
Grip, Handle, Lantern	3	Storage Room
Hammer, Hand (Maul)	1	Storage Room on Hooks
Hammer, Hand (Sledge)	2	Hammer Rack
Harness, Safety, Industrial	6	Cabinets
Helmet, Safety (Blue)	2	Storage Room on Hooks
Helmet, Safety (Brown)	4	Storage Room on Hooks
Holder, Light	3	Storage Room
Hook, Boat	2	Storage Room
Kit, Burn	1	Cabinets
Kit, Tagout/Lockout	1	Storage Room
Ladder, ISOPAK	1	Storage Room
Lanyard, Safety Harness	6	Storage Room on Hooks
Life Lines with Stanchions (Set)	1	Storage Room
Life Preserver, Vest	8	Storage Room
Life Preserver, Vest (Stearns Work Vest)	8	Cabinets
Light, Distress, Personal Marker	24	Storage Room
Lights, Navigation (Set)	1	Storage Room
Plug, Ear (Box)	1	Storage Room
Plug, Wood (1 in. X 0 in. X 8 in.)	5	Storage Room
Plug, Wood (10 in. X 7 in. X 12 in.)	5	Storage Room
Plug, Wood (2 in. X 0 in. X 4 in.)	5	Storage Room
Plug, Wood (3 in. X 0 in. X 8 in.)	5	Storage Room
Plug, Wood (7 in. X 3 in. X 10 in.)	5	Storage Room
Plug, Wood (8 in. X 4 in. X 10 in.)	5	Storage Room
Protector, Hearing	6	Storage Room and Cabinets
Pump, Sampler	1	Storage Room
Receiver/Xmtr (VHF/FM Handheld Transceiver)	2	Cabinets
Repair (Repair Kit, Emergency Pipe)	1	Storage Room
Rope, Fibrous (¼ in. x 300 ft) (Spool)	1	Storage Room

Table 1. BII Stowage Location. (Continued)

DESCRIPTION	QTY	LOCATION
Rope, Fibrous (Retrieving Line) (Roll)	1	Cabinets
Shackle, ½ in., 2 Ton	8	Cabinets
Shackle, ¾ in., 4.75 Ton	8	Cabinets
Shackle, 1½ in., 30 Ton	4	Cabinets
Shackle, 1¾ in., 40 Ton	4	Cabinets
Shackle, 5/8 in., 3.25 Ton	8	Cabinets
Shape, Day, Maritime (Black Diamond)	1	Storage Room
Shape, Day, Maritime (Black Round)	2	Storage Room
Shore, Damage (Adjustable Steel Shoring)	4	Storage Room
Signal, Smoke and Illumination	12	Cabinets
Sling, 20 ft, 8400 lbs (Yellow)	4	Cabinets
Sling, 25 ft, 53,000 lbs (Green)	4	Storage Room
Sling, 30 ft, 66,000 lbs (Olive)	4	Storage Room
Sling, 4 ft, 5300 lbs (Green)	4	Cabinets
Sling, 5 ft, 5300 lbs (Green)	4	Cabinets
Sling, 6 ft, 5300 lbs (Green)	4	Cabinets
Snap, Hook (Box)	2	Cabinets
Tape, Reflective (Roll)	1	Shelves
Tester, Pneumatic	1	Storage Room
Tool Kit, General Mechanic's	1	Storage Room
Wedge, Wood (1½ in. X 2 in. X 12 in.)	5	Storage Room
Wedge, Wood (2 in. X 2 in. X 8 in.)	5	Storage Room
Whistle, Ball	24	Cabinets
Work Suit, Stearns	8	Cabinets

END OF WORK PACKAGE

**OPERATOR MAINTENANCE
CAUSEWAY FERRY
SIDE FENDERS
STOWAGE**

INITIAL SETUP:**Personnel Required**Seaman 88K

INTRODUCTION**Scope**

This work package covers stowage of the CF side fenders.

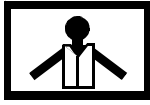
General

The CF side fenders are stacked and secured with ratchet straps to longitudinal track stops in a 20 ft open end container and secured with ratchet straps.

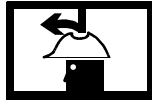
All components are fresh water rinsed, allowed to thoroughly air dry and preserved prior to stowage into the container.

STOWAGE OF SIDE FENDERS

WARNING



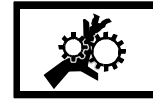
VEST



HELMET PROTECTION



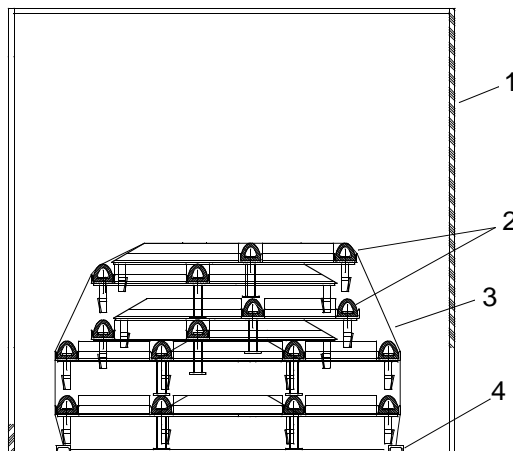
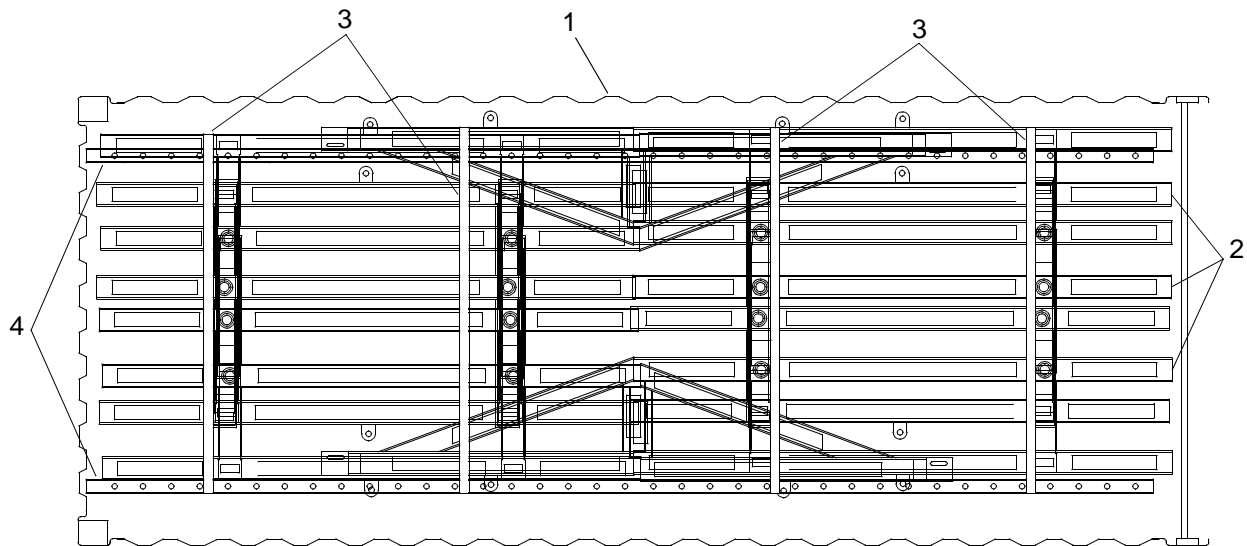
HEAVY PARTS



MOVING PARTS

All personnel must wear personal flotation device, hard hat, safety shoes and gloves during CF operations and maintenance. Failure to observe these precautions could result in serious injury or death.

1. Unlatch and open container (1) doors.



WARNING

Doors must be secured in the open position. Failure to comply could result in death or injury to personnel.

2. Secure container (1) doors open with locking bars, pins or hooks.

WARNING

**HEAVY PARTS**

3. Using a forklift, position and stack side fenders (2) inside container (1) in two opposed rows.
4. Secure side fender (2) stacks with ratchet straps (3) to longitudinal track rails (4) along sides of container (1). Tighten ratchet straps (3).
5. Remove locking bars, pins or hooks securing container doors open.

END OF WORK PACKAGE

**OPERATOR MAINTENANCE
CAUSEWAY FERRY
PILOTHOUSE (OPERATORS CAB)
STOWAGE**

INITIAL SETUP:**Tools**

Tool Kit, General Mechanic's (Rail and Marine) (Item 76, WP 0105 00)
 Gloves, Men's and Women's (Leather Palm) (Item 31, WP 0105 00)
 Goggles, Sun, Wind and Dust (Safety) (Item 34, WP 0105 00)
 Life Preserver, Vest (Item 45, WP 0105 00)
 Helmet, Safety (Brown) (Item 40, WP 0105 00)
 Sling, Lifting 5300 lb (Green) (Item 69, WP 0105 00)
 Qty 4
 2 Ton ½ in. Anchor Shackle (Item 1, WP 0105 00)
 Qty 4

Personnel Required

Seaman 88K (2)

INTRODUCTION**Scope**

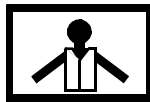
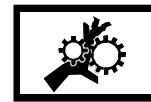
This work package covers stowage of the Causeway Ferry (CF) operators cab.

General

The causeway ferry operators cab is stowed for transport and storage, secured to a pallet. The pallet is covered with a metal frame shipping crate, which is secured to the pallet platform. The operators cab and the metal frame shipping crate are secured to the pallet platform with clips.

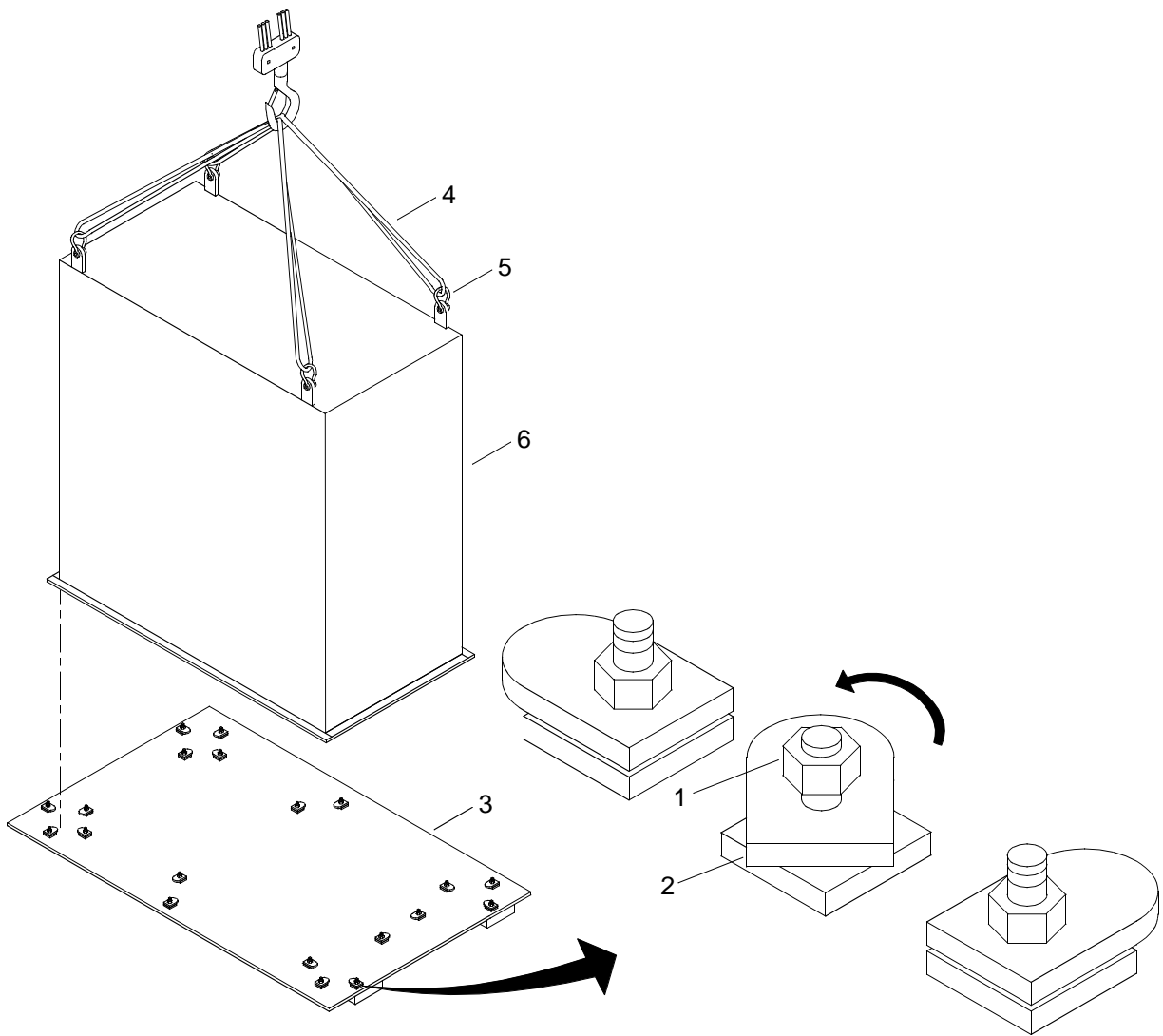
STOWAGE OF OPERATORS CAB

WARNING

**VEST****HELMET PROTECTION****HEAVY PARTS****MOVING PARTS**

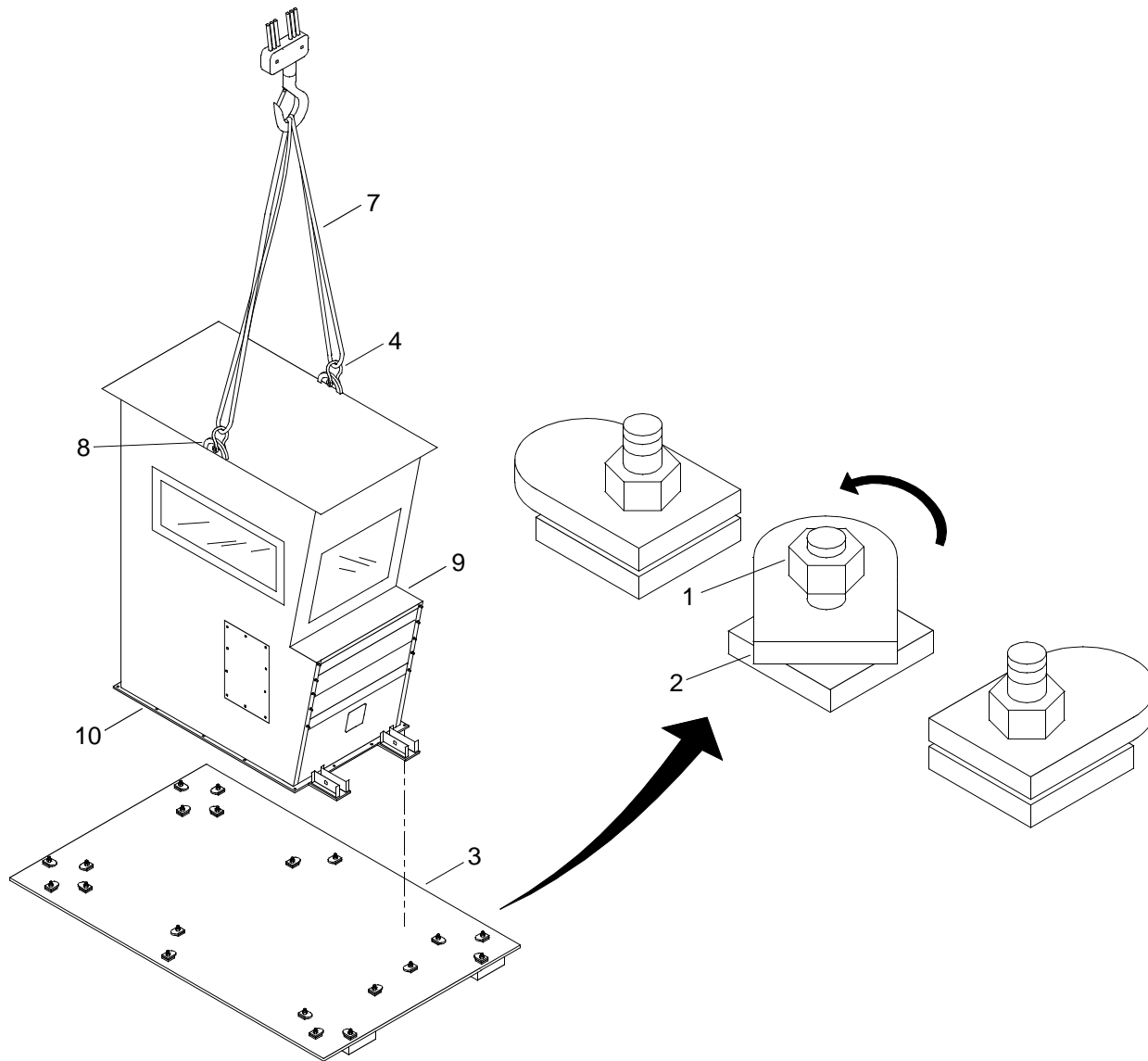
All personnel must wear personal flotation device, hard hat, safety shoes and gloves during CF operations and maintenance. Failure to observe these precautions could result in serious injury or death.

1. Loosen nuts (1) on outer clips (2) of stowage pallet (3).



2. Attach slings (4) and shackles (5) to shipping crate (6).
3. Rotate outer clips (2) away from center.
4. Using crane, raise shipping crate (6) off of stowage pallet (3) and set aside.

5. Attach two 5,300 lb slings (7) to shackles (5).



- 6. Attach slings (7) to crane.
- 7. Attach shackles (4) to lifting padeyes (8).
- 8. Attach slings (7) to shackles (4).

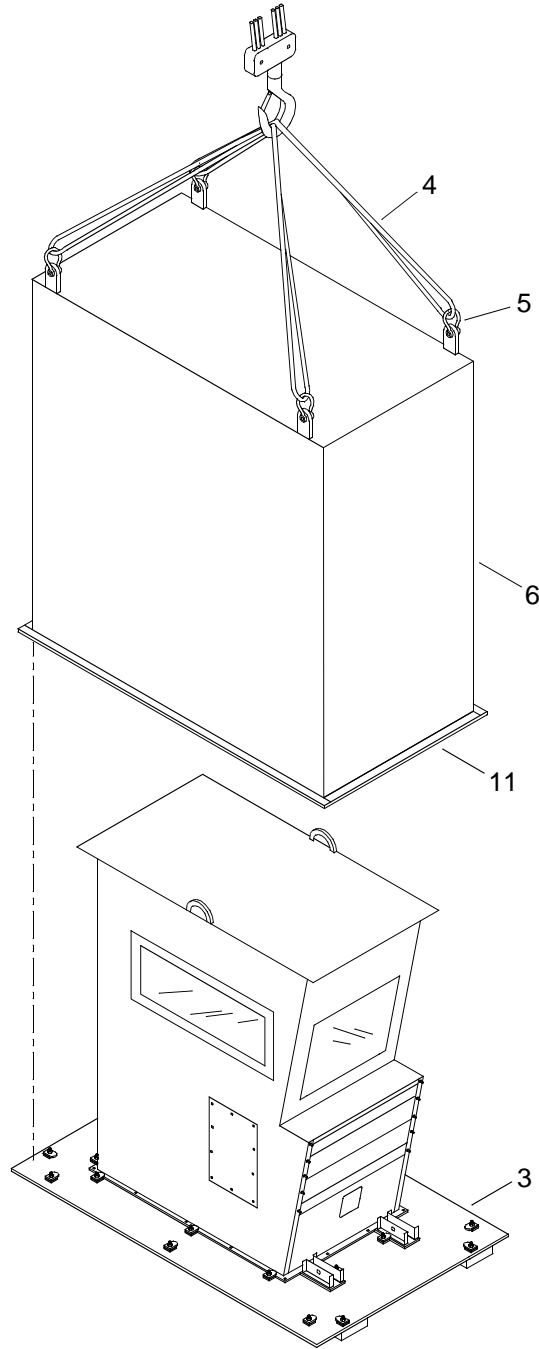
WARNING



HEAVY PARTS

9. Using crane, position operators cab (9) with base (10) centered inside inner ring of clips (2). Use assistant to guide operators cab (9) into position.

10. Rotate inner clips (2) over base (10) of operators cab (9).
11. Hold inner clips (2) in position and tighten nuts (1).
12. Remove lifting equipment from operators cab padeyes (8).
13. Loosen nuts (1) on outer clips (2) of stowage pallet (3).
14. Rotate outer clips (2) away from operators cab (9).



15. Attach slings (4) to crane.

WARNING

**HEAVY PARTS**

16. Using crane lift shipping crate (6) into position over operators cab (9).
17. Have assistant help guide shipping crate (6) down over operators cab (9) so base (11) of shipping crate (6) is positioned within outer ring of clips (2).
18. Rotate outer clips (2) over base (11) of shipping crate (6).
19. Hold outer clips (2) in position and tighten nuts (1).
20. Remove lifting equipment from shipping crate (6).

WARNING

**Do not use shipping crate padeyes for lifting stowed operators cab, use forklift only.
Failure to comply could result in serious injury or death.**

21. Using a forklift, position stowage pallet (3) as required for stowage or shipping.

END OF WORK PACKAGE

**OPERATOR MAINTENANCE
CAUSEWAY FERRY
ANCHORBOARD AND SHIP FENDERING
STOWAGE**

INITIAL SETUP:**Tools**

Tool Kit, General Mechanic's (Rail and Marine) (Item 76, WP 0105 00)
 Gloves, Men's and Women's (Leather Palm) (Item 31, WP 0105 00)
 Goggles, Sun, Wind and Dust (Safety) (Item 34, WP 0105 00)
 Life Preserver, Vest (Item 45, WP 0105 00)
 Helmet, Safety (Brown) (Item 40, WP 0105 00)

Personnel Required

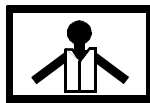
Seaman 88K (2)

INTRODUCTION**Scope**

The causeway ferry anchorboard, ship fendering and flexor inserts are stowed for transport and storage in a 20 ft open end container.

STOWAGE OF ANCHORBOARD AND SHIP FENDERING

WARNING

**VEST****HELMET PROTECTION****HEAVY PARTS****MOVING PARTS**

All personnel must wear personal flotation device, hard hat, safety shoes and gloves during CF operations and maintenance. Failure to observe these precautions could result in serious injury or death.

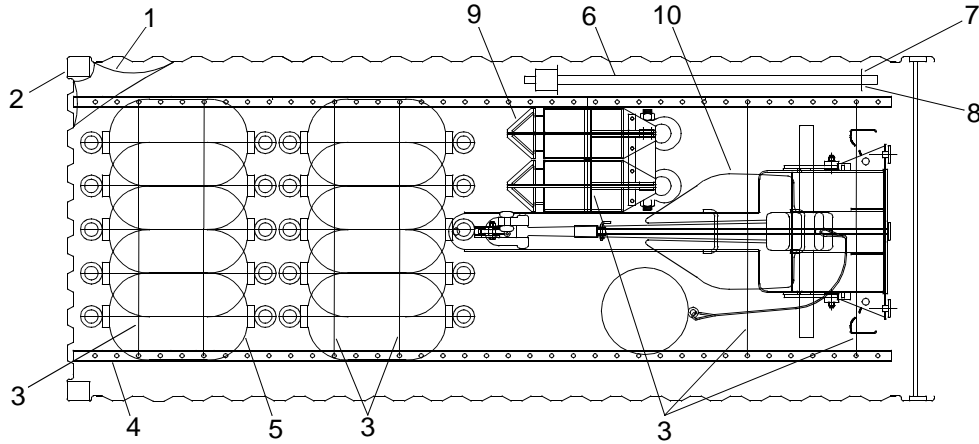
1. Rinse all items to be stowed with fresh water before packing. Allow to thoroughly air dry.
2. Unlatch and open container door.

WARNING

Doors must be secured in the open position. Failure to comply could result in death or injury to personnel.

3. Secure container doors open with locking bars, pins or hooks.

4. Attach cargo net (1) to tiedowns at rear of container (2).



5. Secure cargo net (1) to overhead of container (2).

NOTE

The following steps are typical for stowage of ship fendering.

6. Attach one end of ratchet strap (3) to deck track (4).

WARNING



HEAVY OBJECTS

7. Stack fenders (5).
 8. Place ratchet strap (3) over stack of fenders (5) and attach to deck track (4). Tighten ratchet strap (3).
 9. Pull cargo net (1) over stack of fenders (5).

WARNING



HEAVY OBJECTS

10. Place bow mast (6) in hanger brackets (7).
 11. Install hitch pins (8) in hanger brackets (7).

WARNING

**HEAVY OBJECTS**

12. Using forklift adapter assembly, position flexor inserts (9) on deck of container (2).
13. Attach ratchet straps (3) to deck track (4).
14. Place ratchet straps (3) over top of flexor inserts (9)
15. Attach ratchet straps (3) to deck track (4) and tighten.

WARNING

**HEAVY OBJECTS**

16. Using forklift adapter assembly, position anchorboard assembly (10) on deck of container (2).
17. Attach ratchet straps (3) to deck track (4).
18. Place ratchet straps (3) over anchorboard assembly (9).
19. Pull cargo net (1) over last stack of fenders (5).
20. Attach ratchet straps (3) to deck track (4) and tighten.
21. Close container door.

END OF WORK PACKAGE

CHAPTER 3

OPERATOR TROUBLESHOOTING PROCEDURES
FOR
MODULAR CAUSEWAY SYSTEM (MCS)
CAUSEWAY FERRY (CF)

**OPERATOR MAINTENANCE
CAUSEWAY FERRY
INDEX
TROUBLESHOOTING PROCEDURES INDEX**

MALFUNCTION/SYMP TOM**TROUBLESHOOTING PROCEDURE****ABOVE DECK SYSTEMS**

Main Mast Deck Flood Light(s) Will Not Function	WP 0098 20	■
---	------------	---

Navigation Light(s) Will Not Function	WP 0098 00	
---------------------------------------	------------	--

Bow Light Will Not Function	WP 0098 10	■
-----------------------------	------------	---

PRECISION LIGHTWEIGHT GLOBAL POSITIONING RECEIVER (PLGR)

Does Not Display A Valid Position	WP 0095 00	
-----------------------------------	------------	--

Has Cleared Memory	WP 0096 00	
--------------------	------------	--

Has No Power	WP 0094 00	
--------------	------------	--

DIESEL ENGINE

Fails To Start, Starts With Difficulty And Runs Badly	WP 0065 00	
---	------------	--

Has Sudden Loss Of Power (Heavy Black Smoke)	WP 0063 00	
--	------------	--

Has Sudden Loss Of Power (No Black Smoke)	WP 0068 00	
---	------------	--

Starts With Difficulty And Runs Rough	WP 0067 00	
---------------------------------------	------------	--

Turns Over, But Will Not Start	WP 0064 00	
--------------------------------	------------	--

Will Not Turn Over	WP 0066 00	
--------------------	------------	--

EXHAUST PLENUM

Vent Fan Will Not Operate	WP 0062 00	
---------------------------	------------	--

HYDRAULIC SYSTEM

Has No Pressure	WP 0075 00	
-----------------	------------	--

OPERATORS CAB

Accessories Do Not Function	WP 0085 00	
-----------------------------	------------	--

Ammeter Indicates Discharging Of System	WP 0082 00	
---	------------	--

Clutch Status Light Not Operational	WP 0074 00	■
-------------------------------------	------------	---

Defroster Does Not Operate	WP 0085 10	
----------------------------	------------	--

Engine Audible Alarm Comes On (Normal Operation)	WP 0069 00	
--	------------	--

MALFUNCTIONS/SYMPTOMTROUBLESHOOTING PROCEDURE**OPERATORS CAB (CONT'D)**

■ Engine Oil Pressure Gage Reads 70 PSI (Normal Operation)	WP 0070 00
Navigation Light Audible Pulse Beeper Sounds	WP 0097 00
No Power To Control Panel	WP 0084 00
No Steering Control	WP 0080 00
No Steering Control Indication For The Pump-Jet	WP 0081 00
Overheating (Engine Audible Alarm And Warning Light Will Come On)	WP 0071 00
■ All Circuits Controlled By 3a3cb1-3a3cb10 Are Not Functioning	WP 0085 30
■ Heater Does Not Operate	WP 0085 20

PROPULSION MODULE

Bilge Pumps Do Not Function	WP 0083 00
Drive Train Does Not Operate Freely And Smoothly; Excessive Vibration Is Experienced During Operation	WP 0072 00
Marine Gear Clutch Will Not Engage In Engage/Backflush Directions	WP 0073 00
No Propulsion From Pump-Jet	WP 0076 00
No Steering Control From The Pump-Jet	WP 0078 00
Pump-Jet Can Only Develop A Small Amount Of Thrust (Not Enough Water Being Delivered)	WP 0077 00
Steering Reacts Sluggishly	WP 0079 00

PUBLIC ADDRESS SET (LOUDHAILER)

Has No Power	WP 0086 00
Will Not Transmit Fog Signal To Hailer Horn (Loudhailer External Speaker)	WP 0088 00
Will Not Transmit VHF/FM DSC Transceiver Audio To Hailer Horn (Loudhailer External Speaker)	WP 0089 00
Will Not Transmit Voice To Hailer Horn (Loudhailer External Speaker)	WP 0087 00

MALFUNCTIONS/SYMP TOMTROUBLESHOOTING PROCEDURE**VHF/FM DSC TRANSCEIVER**

Does Not Display Valid Position

WP 0093 00

Has No Power

WP 0090 00

Will Not Receive

WP 0091 00

Will Not Transmit

WP 0092 00

**OPERATOR MAINTENANCE
CAUSEWAY FERRY
EXHAUST PLENUM VENTILATION FAN
TROUBLESHOOTING PROCEDURES**

INITIAL SETUP:**Personnel Required**Seaman 88K

TROUBLESHOOTING PROCEDURE

EXHAUST PLENUM VENT FAN WILL NOT OPERATE

NOTE

This troubleshooting procedure is typical for both the starboard and port vent fans.

SYMPTOM

Ventilation fan does not operate.

MALFUNCTION

VENT FANS toggle switch on the lower control panel (A2) is OFF.

CORRECTIVE ACTION

Position VENT FANS toggle switch on the lower control panel (A2) to ON.

Perform operational check of CF. (WP 0020 00)

MALFUNCTION

VENT FAN circuit breaker on the propulsion module circuit breaker panel (A6) is off.

CORRECTIVE ACTION

Position VENT FAN circuit breaker on the propulsion module circuit breaker panel (A6) to on.

Perform operational check of CF. (WP 0020 00)

MALFUNCTION

Loose or disconnected exhaust fan power cable on vent fan relay enclosure (A8).

CORRECTIVE ACTION

Tighten or connect exhaust fan power cable on vent fan relay enclosure (A8).

Perform operational check of CF. (WP 0020 00)

MALFUNCTION

Ventilation fan still does not operate.

CORRECTIVE ACTION

Contact unit maintenance.

END OF WORK PACKAGE

**OPERATOR MAINTENANCE
CAUSEWAY FERRY
DIESEL ENGINE
TROUBLESHOOTING PROCEDURES**

INITIAL SETUP:**Personnel Required**Seaman 88K

TROUBLESHOOTING PROCEDURE

THE DIESEL ENGINE HAS A SUDDEN LOSS OF POWER (HEAVY BLACK SMOKE)

NOTE

This troubleshooting procedure is typical for both engines.

SYMPTOM

Power from the diesel engine is lost and heavy black smoke emitted from the exhaust plenum.

MALFUNCTION

The air inlet has a blockage.

CORRECTIVE ACTION

Remove the blockage from the air inlet or contact unit maintenance.

Perform operational check of CF. (WP 0020 00)

MALFUNCTION

The return line fuel valve is not open.

CORRECTIVE ACTION

Open the return line fuel valve. (WP 0100 00)

Perform operational check of CF. (WP 0020 00)

MALFUNCTION

The air filter restriction indicator's red button is visible.

CORRECTIVE ACTION

Contact unit maintenance.

MALFUNCTION

Diesel engine still has power loss and heavy black smoke observed.

CORRECTIVE ACTION

Contact unit maintenance.

END OF WORK PACKAGE

**OPERATOR MAINTENANCE
CAUSEWAY FERRY
DIESEL ENGINE
TROUBLESHOOTING PROCEDURES**

INITIAL SETUP:**Personnel Required**Seaman 88K

TROUBLESHOOTING PROCEDURE

THE DIESEL ENGINE WILL TURN OVER, BUT WILL NOT START

NOTE

This troubleshooting procedure is typical for both engines.

SYMPTOM

The diesel engine fails to start, but turns over.

MALFUNCTION

No fuel in the fuel tank.

CORRECTIVE ACTION

Fill the fuel tank with fuel. (WP 0100 00)

Perform operational check of CF. (WP 0020 00)

MALFUNCTION

Fuel has drained back and/or leaked out of supply lines.

CORRECTIVE ACTION

Contact unit maintenance.

MALFUNCTION

During severe cold weather conditions, the cold pac starting aid may be out of ether.

CORRECTIVE ACTION

Contact unit maintenance.

MALFUNCTION

The emergency air shutdown was activated.

CORRECTIVE ACTION

Reset the emergency air shutdown solenoid valve. If engine still won't start, contact unit maintenance.

MALFUNCTION

The fuel shutoff valves are closed.

CORRECTIVE ACTION

Open the fuel shutoff valves. (WP 0100 00)

Perform operational check of CF. (WP 0020 00)

MALFUNCTION

Water is discovered in the fuel in the fuel water separator.

CORRECTIVE ACTION

Contact unit maintenance

MALFUNCTION

The engine is turning slowly.

CORRECTIVE ACTION

Ensure the marine gear is not engaged.

Perform operational check of CF. (WP 0020 00)

If the battery output is low or if the starter is faulty, contact unit maintenance.

MALFUNCTION

Diesel engine still will not start, but turns over.

CORRECTIVE ACTION

Contact unit maintenance.

END OF WORK PACKAGE

**OPERATOR MAINTENANCE
CAUSEWAY FERRY
DIESEL ENGINE
TROUBLESHOOTING PROCEDURES**

INITIAL SETUP:**Personnel Required**Seaman 88K

TROUBLESHOOTING PROCEDURE

THE DIESEL ENGINE FAILS TO START, STARTS WITH DIFFICULTY AND RUNS BADLY

NOTE

This troubleshooting procedure is typical for both engines.

SYMPTOM

The diesel engine fails to start, starts with difficulty or runs badly.

MALFUNCTION

The fuel shutoff valves are closed.

CORRECTIVE ACTION

Open the fuel shutoff valves. (WP 0100 00)

Perform operational check of CF. (WP 0020 00)

MALFUNCTION

Water is discovered in the fuel in the fuel water separator.

CORRECTIVE ACTION

Contact unit maintenance.

MALFUNCTION

The engine is not getting enough air.

CORRECTIVE ACTION

Check air cleaners for red buttons. If visible, contact unit maintenance.

Check that air flapper valve is open.

Perform operational check of CF. (WP 0020 00)

MALFUNCTION

No indication of load on ammeter.

CORRECTIVE ACTION

Contact unit maintenance.

MALFUNCTION

Diesel engine still fails to start, starts with difficulty or runs badly.

CORRECTIVE ACTION

Contact unit maintenance.

END OF WORK PACKAGE

**OPERATOR MAINTENANCE
CAUSEWAY FERRY
DIESEL ENGINE
TROUBLESHOOTING PROCEDURES**

INITIAL SETUP:**Personnel Required**Seaman 88K

TROUBLESHOOTING PROCEDURE

THE DIESEL ENGINE WILL NOT TURN OVER

NOTE

This troubleshooting procedure is typical for both engines.

SYMPTOM

The diesel engine fails to turn over.

MALFUNCTION

Electrical power to the starter controls are not on.

CORRECTIVE ACTION

Verify the ENG POWER toggle switch on the middle control panel (A1) is in the ON position. (WP 0006 00)

Perform operational check of CF. (WP 0020 00)

MALFUNCTION

The CLUTCH switch on the lower control panel (A2) is in the BACKFLUSH or FORWARD position.

CORRECTIVE ACTION

Return the CLUTCH switch to the DISENGAGE position. (WP 0006 00)

Perform operational check of CF. (WP 0020 00)

MALFUNCTION

No power is being received from the batteries.

CORRECTIVE ACTION

Check battery terminals for loose connections.

Perform operational check of CF. (WP 0020 00)

If batteries are weak or appear to be dead, contact unit maintenance.

MALFUNCTION

Diesel engine still will not turn over.

CORRECTIVE ACTION

Contact unit maintenance.

END OF WORK PACKAGE

**OPERATOR MAINTENANCE
CAUSEWAY FERRY
DIESEL ENGINE
TROUBLESHOOTING PROCEDURES**

INITIAL SETUP:**Personnel Required**Seaman 88K

TROUBLESHOOTING PROCEDURE

THE DIESEL ENGINE STARTS WITH DIFFICULTY AND RUNS ROUGH

NOTE

This troubleshooting procedure is typical for both engines.

SYMPTOM

The diesel engine starts with difficulty and runs rough.

MALFUNCTION

Fuel shutoff valves are not open.

CORRECTIVE ACTION

Open fuel shutoff valves. (WP 0100 00)

Perform operational check of CF. (WP 0020 00)

MALFUNCTION

Water is discovered in the fuel in the fuel water separator.

CORRECTIVE ACTION

Contact unit maintenance.

MALFUNCTION

Diesel engine still starts with difficulty and runs rough.

CORRECTIVE ACTION

Contact unit maintenance.

END OF WORK PACKAGE

**OPERATOR MAINTENANCE
CAUSEWAY FERRY
DIESEL ENGINE
TROUBLESHOOTING PROCEDURES**

INITIAL SETUP:**Personnel Required**Seaman 88K

TROUBLESHOOTING PROCEDURE

THE DIESEL ENGINE HAS A SUDDEN LOSS OF POWER (NO BLACK SMOKE)

NOTE

This troubleshooting procedure is typical for both engines.

SYMPTOM

Power from the diesel engine is lost, but no black smoke emitted from the exhaust plenum.

MALFUNCTION

Water is discovered in the fuel in the fuel water separator.

CORRECTIVE ACTION

Contact unit maintenance.

MALFUNCTION

Fuel shutoff valves are closed.

CORRECTIVE ACTION

Open the fuel shutoff valves. (WP 0100 00)

Perform operational check of CF. (WP 0020 00)

MALFUNCTION

Fuel filter contains contamination.

CORRECTIVE ACTION

Contact unit maintenance.

MALFUNCTION

Diesel engine still has a sudden power loss, but no black smoke observed.

CORRECTIVE ACTION

Contact unit maintenance.

END OF WORK PACKAGE

**OPERATOR MAINTENANCE
CAUSEWAY FERRY
DIESEL ENGINE
TROUBLESHOOTING PROCEDURES**

INITIAL SETUP:**Personnel Required**Seaman 88K

TROUBLESHOOTING PROCEDURE

ENGINE AUDIBLE ALARM AND WARNING LIGHT ON (NORMAL OPERATION)

NOTE

This troubleshooting procedure is typical for both starboard and port engines.

SYMPTOM

Audible engine alarm and warning light is on.

MALFUNCTIONOIL PRESSURE gauge on the middle control panel A1 reads below 32 PSI (2.2 kp/cm²).**CORRECTIVE ACTION**

Stop engine, allow engine to cool down and add oil to the engine. (WP 0100 00)

Perform operational check of CF. (WP 0020 00)

MALFUNCTION

WATER TEMP gauge on the middle control panel A1 reads above 185°F (83°C).

CORRECTIVE ACTION

WARNING

**HOT AREA**

Cooling system is hot. Do not touch the cap with your bare hands. Never take off cap while engine is overheated. Failure to comply may result in serious personnel injury.

Stop engine, allow engine to cool down and add coolant. (WP 0100 00)

Perform operational check of CF. (WP 0020 00)

MALFUNCTION

Audible engine alarm is still on.

CORRECTIVE ACTION

Contact unit maintenance.

END OF WORK PACKAGE

**OPERATOR MAINTENANCE
CAUSEWAY FERRY
DIESEL ENGINE
TROUBLESHOOTING PROCEDURES**

INITIAL SETUP:**Personnel Required**Seaman 88K

TROUBLESHOOTING PROCEDURE

ENGINE OIL PRESSURE GAUGE READS ABOVE 70 PSI (NORMAL OPERATION)

NOTE

This troubleshooting procedure is typical for both starboard and port engines.

SYMPTOM

Engine oil pressure gauge reads above 70 PSI.

MALFUNCTION

Oil pressure gauge on the middle control panel A1 reading above maximum pressure of 70 PSI indicating clogged oil filter or clogged lines.

CORRECTIVE ACTION

Stop engine and contact unit maintenance.

END OF WORK PACKAGE

**OPERATOR MAINTENANCE
CAUSEWAY FERRY
DIESEL ENGINE
TROUBLESHOOTING PROCEDURES**

INITIAL SETUP:**Personnel Required**Seaman 88K

TROUBLESHOOTING PROCEDURE

ENGINE OVERHEATING (AUDIBLE ALARM AND WARNING LIGHT ON)

WARNING



HOT AREA

Cooling system is hot. Do not touch the cap with your bare hands. Never take off cap while engine is overheated. Contact unit maintenance. Failure to comply may result in serious personnel injury.

CAUTION

Do not use emergency stop to shut off engine. This action shuts off air to the engine. Failure to comply will result in serious damage to the engine.

NOTE

This troubleshooting procedure is typical for both starboard and port engines.

SYMPTOM

Audible engine alarm and engine warning light is on.

MALFUNCTION

The engine is overheating.

CORRECTIVE ACTION

Reduce engine speed to idle.

Turn off engine by means of the engine STOP push button on the middle control panel (A1) for affected engine.

Contact unit maintenance.

END OF WORK PACKAGE

**OPERATOR MAINTENANCE
CAUSEWAY FERRY
DRIVE TRAIN
TROUBLESHOOTING PROCEDURES**

INITIAL SETUP:**Personnel Required**Engineer 88L

TROUBLESHOOTING PROCEDURE

DRIVE TRAIN DOES NOT OPERATE FREELY AND SMOOTHLY; EXCESSIVE VIBRATION IS EXPERIENCED DURING OPERATION

NOTE

This troubleshooting procedure is typical for both the starboard and port marine transmissions.

SYMPTOM

Excessive vibration is experienced during operation of the drive train.

MALFUNCTION

Foreign objects in pump-jet water inlet.

CORRECTIVE ACTION

Perform backflush.

Perform operational check of CF. (WP 0020 00)

MALFUNCTION

Vibration still present after backflush.

CORRECTIVE ACTION

Contact unit maintenance.

END OF WORK PACKAGE

**OPERATOR MAINTENANCE
CAUSEWAY FERRY
MARINE GEAR
TROUBLESHOOTING PROCEDURES**

INITIAL SETUP:**Personnel Required**Seaman 88K

TROUBLESHOOTING PROCEDURE

MARINE GEAR CLUTCH WILL NOT ENGAGE IN ENGAGE/BACKFLUSH DIRECTIONS.

NOTE

This troubleshooting procedure is typical for both marine gears.

SYMPTOM

The marine gear clutch will not engage in the engage/disengage directions.

MALFUNCTION

The CLUTCH circuit breaker on the propulsion module circuit breaker panel (A6) is not in on position.

CORRECTIVE ACTION

Move the CLUTCH circuit breaker to the on position. (WP 0006 00)

Perform operational check of CF. (WP 0020 00)

MALFUNCTION

The oil level in the marine gear is low.

CORRECTIVE ACTION

Add oil to the proper level on the dipstick. (WP 0100 00)

Perform operational check of CF. (WP 0020 00)

MALFUNCTION

The marine gear filter screen is clogged.

CORRECTIVE ACTION

Contact unit maintenance.

MALFUNCTION

The clutch solenoid is not functioning properly.

CORRECTIVE ACTION

Contact unit maintenance.

MALFUNCTION

The marine gear clutch still will not engage in the engage/disengage directions.

CORRECTIVE ACTION

Contact unit maintenance.

END OF WORK PACKAGE

**OPERATOR MAINTENANCE
CAUSEWAY FERRY
MARINE GEAR CLUTCH STATUS LIGHT
TROUBLESHOOTING PROCEDURES**

INITIAL SETUP:**Personnel Required**Seaman 88k

TROUBLESHOOTING PROCEDURE

CLUTCH STATUS LIGHT NOT OPERATIONAL

NOTE

This troubleshooting procedure is typical for both marine gears.

SYMPTOM

Light for clutch status not operational.

MALFUNCTION

CLUTCH circuit breaker on propulsion module circuit breaker panel A6 is off.

CORRECTIVE ACTION

Position CLUTCH circuit breaker to on.

Perform operational check of CF. (WP 0020 00)

MALFUNCTION

Indicator light bulb failed.

CORRECTIVE ACTION

Contact unit maintenance.

END OF WORK PACKAGE

**OPERATOR MAINTENANCE
CAUSEWAY FERRY
HYDRAULIC SYSTEM
TROUBLESHOOTING PROCEDURES**

INITIAL SETUP:**Personnel Required**Seaman 88K

TROUBLESHOOTING PROCEDURE

THE HYDRAULIC SYSTEM HAS NO PRESSURE

NOTE

This troubleshooting procedure is typical for both hydraulic systems.

SYMPTOM

No hydraulic steering system pressure.

MALFUNCTION

The hydraulic fluid level is low.

CORRECTIVE ACTION

Add hydraulic fluid to the proper level. (WP 0100 00)

Perform operational check of CF. (WP 0020 00)

MALFUNCTION

The hydraulic steering system still has no pressure.

CORRECTIVE ACTION

Contact unit maintenance.

END OF WORK PACKAGE

**OPERATOR MAINTENANCE
CAUSEWAY FERRY
PUMP-JET
TROUBLESHOOTING PROCEDURES**

INITIAL SETUP:**Personnel Required**Seaman 88K

TROUBLESHOOTING PROCEDURE**NO PROPULSION FROM PUMP-JET****NOTE**

This troubleshooting procedure is typical for both the starboard and port pump-jets.

SYMPTOM

Pump-jet has no propulsion.

MALFUNCTION

Diesel engine is not running.

CORRECTIVE ACTION

Start diesel engine. (WP 0020 00)

MALFUNCTION

The marine gear clutch is not engaged.

CORRECTIVE ACTION

Check to ensure the CLUTCH toggle switch on the lower control panel A2 is in either the FORWARD or BACKFLUSH position. (WP 0020 00)

MALFUNCTION

The pump-jet intake is clogged with foreign objects.

CORRECTIVE ACTION

Backflush the pump-jet to clear the intake.

Perform operational check of CF. (WP 0020 00)

MALFUNCTION

Pump-jet still not delivering propulsion.

CORRECTIVE ACTION

Contact unit maintenance.

END OF WORK PACKAGE

**OPERATOR MAINTENANCE
CAUSEWAY FERRY
PUMP-JET
TROUBLESHOOTING PROCEDURES**

INITIAL SETUP:**Personnel Required**Engineer 88L

TROUBLESHOOTING PROCEDURE

PUMP-JET CAN ONLY DEVELOP A SMALL AMOUNT OF THRUST (NOT ENOUGH WATER IS BEING DELIVERED)

NOTE

This troubleshooting procedure is typical for both the starboard and port pump-jets.

SYMPTOM

Only a small amount of thrust from the pump-jet.

MALFUNCTION

Diesel engine is not operating at required speed.

CORRECTIVE ACTION

Increase the speed of the diesel engine. (WP 0020 00)

MALFUNCTION

Pump-jet intake or impeller is clogged with foreign objects.

CORRECTIVE ACTION

Disengage pump-jet and back flush to clear debris. (WP 0020 00)

MALFUNCTION

Pump-jet still delivers only a small a small amount of thrust.

CORRECTIVE ACTION

Contact unit maintenance.

END OF WORK PACKAGE

**OPERATOR MAINTENANCE
CAUSEWAY FERRY
PUMP-JET
TROUBLESHOOTING PROCEDURES**

INITIAL SETUP:**Personnel Required**Seaman 88K

TROUBLESHOOTING PROCEDURE**NO STEERING CONTROL FROM THE PUMP-JET****NOTE**

This troubleshooting procedure is typical for pump-jet in both the starboard and port powered modules.

SYMPTOM

The pump-jet has no steering control.

MALFUNCTION

The THRUSTER circuit breaker on propulsion module circuit breaker panel (A6) is not on.

CORRECTIVE ACTION

Position THRUSTER circuit breaker on propulsion module circuit breaker panel to the on position. (WP 0006 00)

Perform operational check of CF. (WP 0020 00)

MALFUNCTION

No hydraulic pressure.

CORRECTIVE ACTION

Check that the HPU OIL LEVEL LOW light is not lit on the lower control panel A2. (WP 0006 00).

Perform operational check of CF. (WP 0020 00)

If the HPU OIL LEVEL LOW light is lit, contact unit maintenance.

MALFUNCTION

The pump-jet is still not delivering steering control.

CORRECTIVE ACTION

Contact unit maintenance.

END OF WORK PACKAGE

**OPERATOR MAINTENANCE
CAUSEWAY FERRY
PUMP-JET STEERING
TROUBLESHOOTING PROCEDURES**

INITIAL SETUP:

Personnel Required

Engineer 88L

TROUBLESHOOTING PROCEDURE

STEERING REACTS SLUGGISHLY

NOTE

This troubleshooting procedure is typical for both the starboard and port steering systems.

SYMPTOM

Steering is reacting sluggishly.

MALFUNCTION

Air in the hydraulic system or low hydraulic pressure.

CORRECTIVE ACTION

Contact unit maintenance.

END OF WORK PACKAGE

**OPERATOR MAINTENANCE
CAUSEWAY FERRY
STEERING SYSTEM
TROUBLESHOOTING PROCEDURES**

INITIAL SETUP:**Personnel Required**Engineer 88L

TROUBLESHOOTING PROCEDURE**NO STEERING FROM OPERATORS CAB****NOTE**

This troubleshooting procedure is typical for both steering systems.

SYMPTOM

No steering from operators cab.

MALFUNCTION

The THRUSTER circuit breaker on the propulsion module circuit breaker panel (A6) is not on.

CORRECTIVE ACTION

Position THRUSTER circuit breaker to on. (WP 0006 00)

Perform operational check of CF. (WP 0020 00)

MALFUNCTION

Failed steering control lever.

CORRECTIVE ACTION

Contact unit maintenance.

MALFUNCTION

Hydraulic system not functioning.

CORRECTIVE ACTION

Contact unit maintenance.

END OF WORK PACKAGE

**OPERATOR MAINTENANCE
CAUSEWAY FERRY
PUMP-JET
TROUBLESHOOTING PROCEDURES**

INITIAL SETUP:**Personnel Required**Seaman 88K

TROUBLESHOOTING PROCEDURE

NO STEERING CONTROL INDICATION FOR THE PUMP-JET

NOTE

This troubleshooting procedure is typical for both the starboard and port pump-jets.

SYMPTOM

The pump-jet has no steering control indication.

MALFUNCTION

The THRUSTER INDICATOR circuit breaker on the propulsion module circuit breaker panel A6 is in off position.

CORRECTIVE ACTION

Position THRUSTER circuit breaker to the on position. (WP 0006 00)

Perform operational check of CF. (WP 0020 00)

MALFUNCTION

Low voltage is being supplied by the thrust directional/auxiliary battery junction box A9 batteries.

CORRECTIVE ACTION

Contact unit maintenance.

MALFUNCTION

Failed feedback unit on the pump-jet.

CORRECTIVE ACTION

Contact unit maintenance.

MALFUNCTION

Pump-jet still has no steering control indication.

CORRECTIVE ACTION

Contact unit maintenance.

END OF WORK PACKAGE

**OPERATOR MAINTENANCE
CAUSEWAY FERRY
DIESEL ENGINE
TROUBLESHOOTING PROCEDURES**

INITIAL SETUP:**Personnel Required**Seaman 88K

TROUBLESHOOTING PROCEDURE

AMMETER INDICATES DISCHARGING OF SYSTEM

NOTE

This troubleshooting procedure is typical for both starboard and port engines.

SYMPTOM

System discharge is indicated on the ammeter.

MALFUNCTION

Alternator belts loose, worn or broken or defective alternator.

CORRECTIVE ACTION

Contact unit maintenance.

END OF WORK PACKAGE

**OPERATOR MAINTENANCE
CAUSEWAY FERRY
BILGE PUMPS
TROUBLESHOOTING PROCEDURES**

INITIAL SETUP:**Personnel Required**Seaman 88K

TROUBLESHOOTING PROCEDURE

BILGE PUMP(S) WILL NOT FUNCTION

NOTE

This troubleshooting procedure is typical for all bilge pumps.

SYMPTOM

Bilge pump will not function.

MALFUNCTION

The CONTROL PANEL circuit breaker located on the operators cab circuit breaker panel A3 is off.

CORRECTIVE ACTION

Position CONTROL PANEL circuit breaker to on. (WP 0006 00)

Perform operational check of CF. (WP 0020 00)

MALFUNCTION

A BILGE PUMP circuit breaker located on the propulsion module circuit breaker panel A6 is off.

CORRECTIVE ACTION

Position BILGE PUMP circuit breaker to on. (WP 0006 00)

Perform operational check of CF. (WP 0020 00)

MALFUNCTION

The BILGE PUMP circuit breaker on bilge pump control panel (A5 or A7) is off.

CORRECTIVE ACTION

Position BILGE PUMP circuit breaker on A5 or A7 to REMOTE. (WP 0006 00)

Perform operational check of CF. (WP 0020 00)

MALFUNCTION

Bilge pump(s) faulty.

CORRECTIVE ACTION

Contact unit maintenance.

MALFUNCTION

Bilge pump(s) still will not function.

CORRECTIVE ACTION

Contact unit maintenance.

END OF WORK PACKAGE

**OPERATOR MAINTENANCE
CAUSEWAY FERRY
OPERATORS CAB
TROUBLESHOOTING PROCEDURES**

INITIAL SETUP:**Personnel Required**Seaman 88K

TROUBLESHOOTING PROCEDURE

NO POWER TO THE OPERATORS CAB CONTROL PANELS

SYMPTOM

The operators cab control panels are not receiving power.

MALFUNCTION

The MAIN circuit breaker on the propulsion module circuit breaker panel (A6) is in the OFF position. ■

CORRECTIVE ACTION

Position MAIN circuit breaker to ON. (WP 0006 00)

Perform operational check of CF. (WP 0020 00)

MALFUNCTION

50 amp circuit breaker switch is in the OFF position. ■

CORRECTIVE ACTION

Position 50 amp circuit breaker switch to the ON position. (WP 0006 00)

Perform operational check of CF. (WP 0020 00)

MALFUNCTION

There is still no power to the control panels in the operators cab.

CORRECTIVE ACTION

Contact unit maintenance.

END OF WORK PACKAGE

**OPERATOR MAINTENANCE
CAUSEWAY FERRY
OPERATORS CAB
TROUBLESHOOTING PROCEDURES**

INITIAL SETUP:**Personnel Required**Seaman 88K

TROUBLESHOOTING PROCEDURE

OPERATORS CAB ACCESSORIES DO NOT FUNCTION

SYMPTOM

The operators cab accessories are not functioning.

MALFUNCTION

The MAIN circuit breaker on the propulsion module circuit breaker panel (A6) is in the OFF position.

CORRECTIVE ACTION

Position MAIN circuit breaker to ON. (WP 0006 00)

Perform operational check of CF. (WP 0020 00)

MALFUNCTION

50 amp circuit breaker switch is in the OFF position.

CORRECTIVE ACTION

Position 50 amp circuit breaker switch to the ON position. (WP 0006 00)

Perform operational check of CF. (WP 0020 00)

MALFUNCTION

The individual accessory circuit breakers located on the operators cab circuit breaker panel A3 are in the OFF position.

CORRECTIVE ACTION

Position accessory circuit breakers to ON. (WP 0006 00)

Perform operational check of CF. (WP 0020 00)

MALFUNCTION

Operators cab accessories are still not functioning.

CORRECTIVE ACTION

Contact unit maintenance.

END OF WORK PACKAGE

**OPERATOR MAINTENANCE
CAUSEWAY FERRY
OPERATORS CAB DEFROSTER
TROUBLESHOOTING PROCEDURES**

INITIAL SETUP:**Personnel Required**Seaman 88K

TROUBLESHOOTING PROCEDURE

DEFROSTER FAN DOES NOT OPERATE (NO FAN AND NO HEAT)

SYMPTOM

Defroster fan does not operate (No fan and no heat).

MALFUNCTION

Defroster function selector switch is in the OFF position.

CORRECTIVE ACTION

Place the defroster function selector switch in either the fan only position or the heat position desired

Perform operational check of the defroster. (WP 0020 00)

MALFUNCTION

A3CB5 circuit breaker on the A3 circuit breaker panel is in the OFF position.

CORRECTIVE ACTION

Place the A3CB5 circuit breaker on the A3 circuit breaker panel is to the ON position.

Perform operational check of the defroster. (WP 0020 00)

MALFUNCTION

Thermostat is set to low.

CORRECTIVE ACTION

Check thermostat setting. Rotate thermostat clockwise towards HI to increase heat output.

MALFUNCTION

Defroster has heat output, but fan still does not operate.

CORRECTIVE ACTION

Contact unit maintenance.

MALFUNCTION

The defroster fan still does not work.

CORRECTIVE ACTION

Contact unit maintenance.

END OF WORK PACKAGE

**OPERATOR MAINTENANCE
CAUSEWAY FERRY
OPERATORS CAB HEATER
TROUBLESHOOTING PROCEDURES**

INITIAL SETUP:**Personnel Required**Seaman 88K

TROUBLESHOOTING PROCEDURE

HEATER DOES NOT OPERATE

SYMPTOM

Heater does not operate

MALFUNCTION

Heater function selector switch is in the OFF position.

CORRECTIVE ACTION

Place the heater function selector switch in ON position

Perform operational check of the defroster. (WP 0020 00)

MALFUNCTION

A3CB11 circuit breaker on the A3 circuit breaker panel is in the OFF position.

CORRECTIVE ACTION

Place the A3CB11 circuit breaker on the A3 circuit breaker panel is to the ON position.

Perform operational check of the defroster. (WP 0020 00)

MALFUNCTION

Thermostat is set to low.

CORRECTIVE ACTION

Check thermostat setting. Rotate thermostat clockwise towards HI to increase heat output.

MALFUNCTION

The heater still does not work.

CORRECTIVE ACTION

Contact unit maintenance.

END OF WORK PACKAGE

**OPERATOR MAINTENANCE
CAUSEWAY FERRY
OPERATORS CAB
TROUBLESHOOTING PROCEDURES**

INITIAL SETUP:**Personnel Required**Seaman 88K

TROUBLESHOOTING PROCEDURE

ALL CIRCUITS CONTROLLED BY 3A3CB1-3A3CB10 ARE NOT FUNCTIONING

SYMPTOM

All circuits controlled by operators cab circuit breaker panel A3 3A3CB1-3A3CB10 are not functioning.

MALFUNCTION

The MAIN circuit breaker on the propulsion module circuit breaker panel (A6) is in the OFF position.

CORRECTIVE ACTION

Position MAIN circuit breaker to ON. (WP 0006 00)

Perform operational check of CF. (WP 0020 00)

MALFUNCTION

50 amp circuit breaker switch is in the OFF position.

CORRECTIVE ACTION

Position 50 amp circuit breaker switch to the ON position. (WP 0006 00)

Perform operational check of CF. (WP 0020 00)

MALFUNCTION

All circuits controlled by operators cab circuit breaker panel A3 3A3CB1-3A3CB10 are not functioning.

CORRECTIVE ACTION

Contact unit maintenance.

END OF WORK PACKAGE

**OPERATOR MAINTENANCE
CAUSEWAY FERRY
PUBLIC ADDRESS SET (LOUDHAILER)
TROUBLESHOOTING PROCEDURES**

INITIAL SETUP:**Personnel Required**Seaman 88K

TROUBLESHOOTING PROCEDURE

THE PUBLIC ADDRESS SET (LOUDHAILER) HAS NO POWER

SYMPTOM

No indication of power displayed in the loudhailer display window.

MALFUNCTION

No power to loudhailer.

CORRECTIVE ACTION

Turn loudhailer on. Rotate the OFF/DIM knob clockwise cw on the loudhailer. (WP 0023 00)

Perform operational check of loudhailer. (WP 0023 00)

Check that the power wires are securely attached on the back of the loudhailer.

Perform operational check of loudhailer. (WP 0023 00)

Check that the DC to DC converter power switch is in ON position. (WP 0033 00)

Perform operational check of loudhailer. (WP 0023 00)

Check to DC/DC CONV circuit breaker on the operators cab circuit breaker panel A3 is in the ON position. (WP 0006 00)

Perform operational check of loudhailer. (WP 0023 00)

Check the OPR CAB circuit breaker on the propulsion module circuit breaker panel A6 is in the on position. (WP 0006 00)

Perform operational check of loudhailer. (WP 0023 00)

MALFUNCTION

Still no indication of power displayed in the loudhailer display window.

CORRECTIVE ACTION

Contact unit maintenance.

END OF WORK PACKAGE

**OPERATOR MAINTENANCE
CAUSEWAY FERRY
PUBLIC ADDRESS SET (LOUDHAILER)
TROUBLESHOOTING PROCEDURES**

INITIAL SETUP:**Personnel Required**Seaman 88K

TROUBLESHOOTING PROCEDURE

THE PUBLIC ADDRESS SET (LOUDHAILER) WILL NOT TRANSMIT VOICE TO HAILER HORN (LOUDHAILER EXTERNAL SPEAKER)

SYMPTOM

No voice is being transmitted through the external speaker.

MALFUNCTION

No power to loudhailer.

CORRECTIVE ACTION

Turn loudhailer on. Rotate the OFF/DIM knob clockwise cw on the loudhailer. (WP 0023 00)

MALFUNCTION

No indication of HAILER in the display.

CORRECTIVE ACTION

Press the HAL key. (WP 0023 00)

MALFUNCTION

No indication of TALK in the display when the microphone push to talk switch is pressed.

CORRECTIVE ACTION

Replace the microphone. Contact unit maintenance.

MALFUNCTION

No indication of FWD or AFT in the display after TALK appeared in display.

CORRECTIVE ACTION

Press the FWD or AFT key to select the forward or aft external speaker. (WP 0023 00)

MALFUNCTION

No voice is being transmitted through the external speakers.

CORRECTIVE ACTION

Check that speaker are wires securely attached to forward and aft terminal screws on the back of the loudhailer.

Perform operational check of loudhailer. (WP 0023 00)

MALFUNCTION

Still no voice is being transmitted through the external speaker.

CORRECTIVE ACTION

Contact unit maintenance.

END OF WORK PACKAGE

**OPERATOR MAINTENANCE
CAUSEWAY FERRY
PUBLIC ADDRESS SET (LOUDHAILER)
TROUBLESHOOTING PROCEDURES**

INITIAL SETUP:**Personnel Required**Seaman 88K

TROUBLESHOOTING PROCEDURE

THE PUBLIC ADDRESS SET (LOUDHAILER) WILL NOT TRANSMIT FOG SIGNAL TO HAILER HORN (LOUDHAILER EXTERNAL SPEAKER)

SYMPTOM

No fog signal is being transmitted through the external speaker.

MALFUNCTION

No power to loudhailer.

CORRECTIVE ACTION

Turn loudhailer on. Rotate the OFF/DIM knob clockwise cw on the loudhailer.
(WP 0023 00)

MALFUNCTION

No indication of FOG in the display.

CORRECTIVE ACTION

Press the FOG key. (WP 0023 00)

MALFUNCTION

No indication of MANUAL in the display when manual mode is selected.

CORRECTIVE ACTION

Select manual mode. (WP 0023 00)

MALFUNCTION

No indication of FWD in the display after pressing the FOG key and pressing the push to talk switch on the microphone.

CORRECTIVE ACTION

Replace the microphone. Contact unit maintenance.

MALFUNCTION

No voice is being transmitted through the external speaker.

CORRECTIVE ACTION

Check that speaker wires are securely attached to forward or aft terminal screws on the back of the loudhailer.

Perform operational check of loudhailer. (WP 0023 00)

MALFUNCTION

Still no fog signal is being transmitted through the external speaker.

CORRECTIVE ACTION

Contact unit maintenance.

END OF WORK PACKAGE

**OPERATOR MAINTENANCE
CAUSEWAY FERRY
PUBLIC ADDRESS SET (LOUDHAILER)
TROUBLESHOOTING PROCEDURES**

INITIAL SETUP:**Personnel Required**Seaman 88K

TROUBLESHOOTING PROCEDURE

THE PUBLIC ADDRESS SET (LOUDHAILER) WILL NOT TRANSMIT VHF/FM DSC
TRANSCIVER AUDIO TO HAILER HORN (LOUDHAILER EXTERNAL SPEAKER)

SYMPTOM

No VHF/FM DSC transceiver audio is being transmitted through the external speaker.

MALFUNCTION

No power to loudhailer.

CORRECTIVE ACTION

Turn loudhailer on by rotating the OFF/DIM knob clockwise cw on the
loudhailer. (WP 0023 00)

MALFUNCTION

No indication of AUX in the display.

CORRECTIVE ACTION

Press the AUX key. (WP 0023 00)

MALFUNCTION

No audio is being transmitted through the external speaker.

CORRECTIVE ACTION

Check that speaker wires are securely attached to forward or aft terminal screws on the
back of the loudhailer.

Perform operational check of loudhailer. (WP 0023 00)

MALFUNCTION

Still no VHF/FM DSC transceiver audio is being transmitted through the external speaker.

CORRECTIVE ACTION

Contact unit maintenance.

END OF WORK PACKAGE

**OPERATOR MAINTENANCE
CAUSEWAY FERRY
VHF/FM DSC TRANSCEIVER
TROUBLESHOOTING PROCEDURES**

INITIAL SETUP:**Personnel Required**Seaman 88K

TROUBLESHOOTING PROCEDURE

THE VHF/FM DSC TRANSCEIVER HAS NO POWER

SYMPTOM

No indication of power displayed in the transceiver display window.

MALFUNCTION

No power to transceiver.

CORRECTIVE ACTION

Turn transceiver on. Rotate the VOL knob clockwise cw on the transceiver. (WP 0026 00)

MALFUNCTION

VHF-FM RADIO circuit breaker on the operators cab circuit breaker panel A3 is in the off position.

CORRECTIVE ACTION

Position VHF-FM RADIO circuit breaker to on. (WP 0006 00)

Perform operational check of transceiver. (WP 0026 00)

MALFUNCTION

Still no indication of power to transceiver displayed in display window.

CORRECTIVE ACTION

Contact unit maintenance.

END OF WORK PACKAGE

**OPERATOR MAINTENANCE
CAUSEWAY FERRY
VHF/FM DSC TRANSCEIVER
TROUBLESHOOTING PROCEDURES**

INITIAL SETUP:**Personnel Required**Seaman 88K

TROUBLESHOOTING PROCEDURE

THE VHF/FM DSC TRANSCEIVER WILL NOT RECEIVE

SYMPTOM

The transceiver will not receive a message.

MALFUNCTION

The transceiver will not receive messages.

CORRECTIVE ACTION

Check for transceiver receiving power. (WP 0026 00)

MALFUNCTION

Antenna cable is not secure at connection.

CORRECTIVE ACTION

Tighten antenna cable connector.

Perform operational check of transceiver. (WP 0026 00)

MALFUNCTION

The transceiver still will not receive messages.

CORRECTIVE ACTION

Contact unit maintenance.

END OF WORK PACKAGE

**OPERATOR MAINTENANCE
CAUSEWAY FERRY
VHF/FM DSC TRANSCEIVER
TROUBLESHOOTING PROCEDURES**

INITIAL SETUP:**Personnel Required**Seaman 88K

TROUBLESHOOTING PROCEDURE

THE VHF/FM DSC TRANSCEIVER WILL NOT TRANSMIT

SYMPTOM

The transceiver will not transmit a message.

MALFUNCTION

The transceiver will not transmit messages.

CORRECTIVE ACTION

Check to see if transceiver power is on. (WP 0026 00)

MALFUNCTION

Signal strength does not appear in display when microphone is keyed.

CORRECTIVE ACTION

Check microphone for proper operation. (WP 0026 00)

MALFUNCTION

Antenna cable is not secure at connection.

CORRECTIVE ACTION

Tighten antenna cable connector.

Perform operational check of transceiver. (WP 0026 00)

MALFUNCTION

The transceiver still will not transmit a message.

CORRECTIVE ACTION

Contact unit maintenance.

END OF WORK PACKAGE

**OPERATOR MAINTENANCE
CAUSEWAY FERRY
VHF/FM DSC TRANSCEIVER
TROUBLESHOOTING PROCEDURES**

INITIAL SETUP:**Personnel Required**Seaman 88K

TROUBLESHOOTING PROCEDURE

THE VHF/FM DSC TRANSCEIVER DOES NOT DISPLAY A VALID POSITION

SYMPTOM

Alarm will sound if current position shown in the transceiver display is invalid.

MALFUNCTION

The transceiver initial setup procedures are incorrectly entered.

CORRECTIVE ACTION

Perform initial set up of the transceiver. (WP 0027 00)

MALFUNCTION

PLGR initial setup procedures are incorrectly entered.

CORRECTIVE ACTION

Perform initial set up of PLGR. (WP 0029 00)

MALFUNCTION

OPERATE/PROGRAM switch on the AN/PSN-11 interface and switchbox is in the PROGRAM position.

CORRECTIVE ACTION

Position OPERATE/PROGRAM switch to OPERATE. (WP 0022 00)

MALFUNCTION

SW 3 switch on the interface and switchbox is in the down position.

CORRECTIVE ACTION

Place SW 3 on the interface and switchbox in the up position. (WP 0022 00)

MALFUNCTION

PLGR cable not secure to PLGR connector.

CORRECTIVE ACTION

Securely attach PLGR cable to PLGR connector.

Perform operational check of transceiver. (WP 0026 000)

MALFUNCTION

PLGR cable not secure to J7 connector on back of interface and switchbox.

CORRECTIVE ACTION

Securely attach PLGR cable to J7 connector on back of the interface and switchbox.

Perform operational check of transceiver. (WP 0026 00)

MALFUNCTION

Cable not secure to J3 connector on back of the interface and switchbox.

CORRECTIVE ACTION

Securely attach cable to J3 connector on back of the communications interface and switchbox.

Perform operational check of transceiver. (WP 0026 00)

MALFUNCTION

Current position in the transceiver display is still invalid.

CORRECTIVE ACTION

Contact unit maintenance.

END OF WORK PACKAGE

**OPERATOR MAINTENANCE
CAUSEWAY FERRY
PRECISION LIGHTWEIGHT GLOBAL POSITIONING RECEIVER (PLGR)
TROUBLESHOOTING PROCEDURES**

INITIAL SETUP:**Personnel Required**Seaman 88K

TROUBLESHOOTING PROCEDURE

PRECISION LIGHTWEIGHT GLOBAL POSITIONING RECEIVER (PLGR) HAS NO POWER

SYMPTOM

No indication of power displayed in the PLGR display window.

MALFUNCTION

No power to PLGR.

CORRECTIVE ACTION

Press the ON button on the PLGR. (WP 0029 00)

MALFUNCTION

Power switch is in the OFF position on the AN/PSN-11 interface and switchbox.

CORRECTIVE ACTION

Position power switch to ON PWR position. (WP 0022 00)

Perform operational check of PLGR. (WP 0029 00)

MALFUNCTION

DC/DC CONV circuit breaker on the operators cab circuit breaker panel (A3) is in off position.

CORRECTIVE ACTION

Position DC/DC CONV circuit breaker to on. (WP 0006 00)

Perform operational check of PLGR. (WP 0029 00)

MALFUNCTION

Power switch is in the OFF position on the DC to DC converter.

CORRECTIVE ACTION

Position DC to DC converter power switch to ON. (WP 0033 00)

Perform operational check of PLGR. (WP 0029 00)

MALFUNCTION

PLGR cable not secure to PLGR connector.

CORRECTIVE ACTION

Securely attach PLGR cable to PLGR connector.

Perform operational check of PLGR. (WP 0029 00)

MALFUNCTION

PLGR cable not secure to connector on back of the AN/PSN-11 interface and switchbox.

CORRECTIVE ACTION

Securely attach PLGR cable to connector on back of the AN/PSN-11 interface and switchbox.

Perform operational check of PLGR. (WP 0029 00)

MALFUNCTION

Still no power to PLGR.

CORRECTIVE ACTION

Contact unit maintenance.

END OF WORK PACKAGE

**OPERATOR MAINTENANCE
CAUSEWAY FERRY
PRECISION LIGHTWEIGHT GLOBAL POSITIONING RECEIVER (PLGR)
TROUBLESHOOTING PROCEDURES**

INITIAL SETUP:**Personnel Required**Seaman 88K

TROUBLESHOOTING PROCEDURE

PRECISION LIGHTWEIGHT GLOBAL POSITIONING RECEIVER (PLGR) DOES NOT
DISPLAY A VALID POSITION

SYMPTOM

Current position shown in PLGR display is not valid.

MALFUNCTION

Initial setup procedures are incorrectly entered.

CORRECTIVE ACTION

Perform initial set up of PLGR. (WP 0029 00)

MALFUNCTION

PLGR external antenna cable connections on back of AN/PSN-11 interface and switchbox not
securely tightened.

CORRECTIVE ACTION

Securely attach antenna cable connectors to antenna connector receptacles on back of
AN/PSN-11 interface and switchbox.

Perform operational check of PLGR. (WP 0029 00)

MALFUNCTION

External antenna cable connection on back of GPS antenna not securely tightened.

CORRECTIVE ACTION

Securely attach antenna cable connector to antenna connector receptacle on back of
GPS antenna.

Perform operational check of PLGR. (WP 0029 00)

MALFUNCTION

Current position shown in PLGR display is still invalid.

CORRECTIVE ACTION

Contact unit maintenance.

END OF WORK PACKAGE

**OPERATOR MAINTENANCE
CAUSEWAY FERRY
PRECISION LIGHTWEIGHT GLOBAL POSITIONING RECEIVER (PLGR)
TROUBLESHOOTING PROCEDURES**

INITIAL SETUP:**Personnel Required**Seaman 88K

TROUBLESHOOTING PROCEDURE

PRECISION LIGHTWEIGHT GLOBAL POSITIONING RECEIVER (PLGR) HAS
CLEARED MEMORY

SYMPTOM

While observing PLGR display, "WARNING, The receiver has cleared memory" appears in display.

MALFUNCTION

Memory battery voltage is low or memory battery is not installed.

CORRECTIVE ACTION

Replace memory battery. Contact unit maintenance.

Perform initial set up of PLGR. (WP 0020 00)

MALFUNCTION

PLGR still has a cleared memory.

CORRECTIVE ACTION

Replace PLGR unit. Contact unit maintenance.

END OF WORK PACKAGE

**OPERATOR MAINTENANCE
CAUSEWAY FERRY
NAVIGATION LIGHTS
TROUBLESHOOTING PROCEDURES**

INITIAL SETUP:**Personnel Required**Seaman 88K

TROUBLESHOOTING PROCEDURE

NAVIGATION LIGHT AUDIBLE PULSE BEEPER SOUNDS

SYMPTOM

Audible pulse beeper sounds indicating one or more navigation lights not working.

MALFUNCTION

All lights on the mast are out.

CORRECTIVE ACTION

Check the NAV LIGHTS circuit breaker on the operators cab circuit breaker panel A3 is on. (WP 0006 00)

Perform operational check of CF. (WP 0020 00)

MALFUNCTION

Only one light out.

CORRECTIVE ACTION

Check for burned out primary navigation light. Move the toggle switch from PRIMARY to SPARE on the mast enclosure assembly A7. (WP 0006 00)

Perform operational check of CF. (WP 0020 00)

If primary bulb is burned out, contact unit maintenance.

END OF WORK PACKAGE

**OPERATOR MAINTENANCE
CAUSEWAY FERRY
NAVIGATION LIGHTS
TROUBLESHOOTING PROCEDURES**

INITIAL SETUP:**Personnel Required**Seaman 88K

TROUBLESHOOTING PROCEDURE

NAVIGATION LIGHT(S) WILL NOT FUNCTION

SYMPTOM

No illumination from the navigation light (s).

MALFUNCTION

The NAV LIGHTS circuit breaker on the operators cab circuit breaker panel A3 is off.

CORRECTIVE ACTION

Position NAV LIGHTS circuit breaker to on. (WP 0006 00)

Perform operational check of CF. (WP 0020 00)

MALFUNCTION

A blown fuse is found in the mast enclosure assembly.

CORRECTIVE ACTION

Replace the fuse. Contact unit maintenance.

MALFUNCTION

The navigation light(s) still do not illuminate.

CORRECTIVE ACTION

Contact unit maintenance.

END OF WORK PACKAGE

**OPERATOR MAINTENANCE
CAUSEWAY FERRY
BOW MAST LIGHT
TROUBLESHOOTING PROCEDURES**

INITIAL SETUP:**Personnel Required**Seaman 88K

TROUBLESHOOTING PROCEDURE

BOW LIGHT NOT FUNCTIONING

SYMPTOM

Bow light not functioning.

MALFUNCTION

Bad lamp.

CORRECTIVE ACTION

Replace lamp. Contact unit maintenance.

MALFUNCTION

Bad battery connections.

CORRECTIVE ACTION

Contact unit maintenance.

MALFUNCTION

Defective batteries.

CORRECTIVE ACTION

Contact unit maintenance.

END OF WORK PACKAGE

**OPERATOR MAINTENANCE
CAUSEWAY FERRY
MAIN MAST DECK FLOODLIGHT
TROUBLESHOOTING PROCEDURES**

INITIAL SETUP:**Personnel Required**Seaman 88K

TROUBLESHOOTING PROCEDURE

MAIN MAST DECK FLOODLIGHT (S) WILL NOT FUNCTION

SYMPTOM

No illumination from the main mast deck floodlight (s).

MALFUNCTION

The deck floodlight A3CB12 circuit breaker located on the operators cab circuit breaker panel A3 is off.

CORRECTIVE ACTION

Position deck floodlight A3CB12 circuit breaker to ON. (WP 0006 00)

Perform operational check of CF. (WP 0020 00)

MALFUNCTION

The main mast deck floodlight (s) still do not illuminate.

CORRECTIVE ACTION

Contact unit maintenance.

END OF WORK PACKAGE

CHAPTER 4

**OPERATOR MAINTENANCE INSTRUCTIONS
FOR
MODULAR CAUSEWAY SYSTEM (MCS)
CAUSEWAY FERRY (CF)**

**OPERATOR MAINTENANCE
CAUSEWAY FERRY
PREVENTIVE MAINTENANCE CHECKS AND SERVICES (PMCS)
PROCEDURES INTRODUCTION**

INTRODUCTION

General

Preventive Maintenance Checks and Services (PMCS) are performed to keep the warping tug equipment in operating condition. The checks are used to find, correct or report problems. Crew members are to do the PMCS as shown in the PMCS table. Preventative maintenance checks and services are performed every day the equipment is operated, using the PMCS table.

Before you begin operating the equipment, do "Before PMCS".

During operation, do "During PMCS".

After operation, do "After PMCS".

Do "Monthly PMCS" once a month. If the equipment has not been operated in a month, also do "After PMCS" at the same time.

If you are operating the equipment for the first time, do the "Monthly PMCS" the first time you do your "Before PMCS".

If you find something wrong when performing PMCS fix it if you can using troubleshooting procedures and/or maintenance procedures.

1. The right-hand column of the PMCS table list conditions that make the vessel not fully mission capable. Write up items not fixed on DA Form 2404 for unit maintenance. For further information on how to use this form, see DA PAM 738-750.

Leakage Definition

CAUTION

Equipment operation is allowed with minor leakages (Class I or II), except for fuel leaks. Of course, consideration must be given to the fluid capacity of the item or system being checked. When in doubt, ask your supervisor. Failure to maintain proper fluid levels could result in damage to equipment.

When operating with Class I or II leaks, continue to check fluid levels as required in your PMCS.

Class III leaks should be reported immediately to your supervisor.

It is necessary to know how fluid leakage affects the status of the equipment. The following are definitions of the classes of leakage an operator or crew member needs to know to be able to determine the condition of the leak. Learn and then be familiar with them and REMEMBER - WHEN IN DOUBT, ASK YOUR SUPERVISOR.

Leakage definitions for Crew/Operator PMCS.

CLASS I - Seepage of fluid (as indicated by wetness or discoloration) not great enough to form drops.

CLASS II - Leakage of fluid great enough to form drops, but not enough to cause drops to drip from item being checked.

CLASS III - Leakage of fluid great enough to form drops that fall from the item being checked.

Inspection

Look for signs of a problem or trouble. Senses help here. You can feel, smell, hear or see many problems. Be alert when on the equipment.

Inspect to see if items are in good condition. Are they correctly assembled, stowed, secured, excessively worn, leaking, corroded or properly lubricated? Correct any problems found or notify unit maintenance.

There are some common items to check all over the equipment. These include the following:

2. Bolts, clamps, nuts and screws: Continuously check for looseness. Look for chipped paint, bare metal, rust or corrosion around bolt and screw heads and nuts. Tighten them when you find them loose. If tools are not available, contact unit maintenance.
3. Welds: Many items on the equipment are welded. To check these welds, look for chipped paint, rust, corrosion or gaps. When these conditions exist, notify unit maintenance on DA Form 2404.
4. Electrical wires, connectors and harnesses: Tighten loose connectors. Look for cracked or broken insulation, bare wires and broken connectors. If any are found, notify unit maintenance.
5. Hoses and fluid lines: Look for wear, damage and leaks and make sure clamps and fittings are tight. Wet spots mean a leak. A stain by a fitting or connector can also mean a leak. When you find a leak, notify unit maintenance.

Lubrication Service Intervals - Normal Conditions

For safer, more trouble free operations, make sure that your equipment is serviced when it needs it. For the proper lubrication and service intervals, see the PMCS section of this manual.

Lubrication Service Intervals - Unusual Conditions

Your equipment will require extra service and care when you operate under unusual conditions. High or low temperatures or long periods of hard use will break down the lubricant, requiring you to add or change lubricant more often.

Lubrication Intervals

The following lubrication interval symbols are used in the PMCS table:

D - daily	W - weekly
M - monthly	Q - quarterly
S - semiannually	H - hours operated
A - annually	

Lubrication Symbols

The following lubrication symbols are used in the PMCS table:

OE/HDO-40 - Lubricating Oil, internal combustion engine, tactical service, SAE 40, API Class CD-II, MIL-L-2104D, Sulfated Ash: less than 1.0%, Temperature Range -25° - 150° F.

OE/HDO-50 - Lubricating Oil, internal combustion engine, tactical service, SAE 50, MIL-L-2104F or SAE 50, MIL-L-46152. Temperature Range 0° - 150° F.

GO-80/90 - Lubricating oil, gear, multipurpose, MIL-L-2105, Grade 80/90, ISO VG 150, AGMA4 EP.

DTE-25 - Hydraulic fluid, Mobil DTE-25, ISO viscosity grade 46.

LUBRIPLATE - Grease, wire rope, exposed gear, 1200-2, MIL-G-18458.

WTR - Grease, aircraft, general purpose, wide temperature.

GAA - Grease, Lithium Base, MIL-G-10924.

GGP - Grease, General Purpose, MIL-G-23549

S-750 - Antifreeze, ethylene glycol inhibited, heavy duty, MIL-A-46153. Temperature Range -25° - 150°F.

Oil Filters

Oil filters shall be serviced/cleaned/changed, as applicable, when:

They are known to be contaminated or clogged.

Service is recommended by AOAP laboratory analysis.

At prescribed hard time intervals.

Army Oil Analysis Program (AOAP)

The warping tug diesel engines, marine transmission gearcases, transfer cases, hydraulic systems and winch engine oil are enrolled in the Army Oil Analysis Program. Refer to DA PAM 738-750 for the Army Oil Analysis Program. Causeway ferry components will be sampled at the following intervals:

Warping Tug Engines - Sample crankcase oil every 90 days or 100 operating hours, whichever occurs first, as prescribed by DA PAM 738-750.

Marine Transmission Gearcases - Sample oil every 90 days or 100 operating hours, whichever occurs first, as prescribed by DA PAM 738-750.

Transfer Cases - Sample oil every 90 days or 100 operating hours, whichever occurs first, as prescribed by DA PAM 738-750.

Hydraulic Systems - Sample oil every 180 days, as prescribed by DA PAM 738-750.

Warranty Information

For equipment under manufacturer's warranty, hard time oil service intervals shall be followed. Intervals shall be shortened if lubricants are known to be contaminated or if operation is under adverse conditions, such as: longer than usual operating hours, extended idling period or extreme dust.

Cleaning And Lubrication

Proper cleaning and lubrication can aid in avoiding possible problems or trouble, so make it a habit to do the following:

CAUTION

Follow all cleaning and lubrication instructions carefully, failure to do so can result in damage to equipment.

1. Thoroughly wash all equipment exposed to salt spray with clean, fresh water.
2. Clean parts to be lubricated with cleaner, type II, MIL-C-29602 or equivalent. Do not use fluid or semi-fluid lubricant on SFD coated surface. Wipe surface dry before lubricating.
3. Clean grease fittings before lubrication.
4. Lubricate all equipment at conclusion of the operation before equipment storage.
5. Always use the PMCS lubrication instructions as a guide.
6. Never use too much lubricant.
7. Never use the wrong type or grade of lubricant.
8. Lubricate more during constant use and less during inactive periods.
9. Use the correct grade of lubricant for seasonal temperature expected.

Corrosion Prevention And Control (CPC)

Corrosion Prevention and Control (CPC) of Army materiel is a continuing concern. It is important that any corrosion problems with this item be reported so that the problem can be corrected and improvements can be made to prevent the problem in future items.

Corrosion is typically associated with rusting of metals or galvanic corrosion which produces a white powder. The category of corrosion also includes deterioration of other materials, such as rubber and plastic. Unusual cracking, softening, swelling, or breaking of the materials may be a corrosion problem. If a corrosion problem is identified, it can be reported using SF 368, Product Quality Deficiency Report. Use of key words such as "corrosion", "rust", "deterioration" or "cracking" will ensure that the information is identified as a CPC Problem. The form should be submitted to the address specified in DA PAM 738-750.

**OPERATOR MAINTENANCE
CAUSEWAY FERRY
PREVENTIVE MAINTENANCE CHECKS AND SERVICES (PMCS)
AND LUBRICATION PROCEDURES**

INITIAL SETUP:**Tools**

Tool Kit, General Mechanic's (Rail and Marine) (Item 78, WP 0105 00)
Gloves, Men's and Women's (Leather Palm) (Item 31, WP 0105 00)
Goggles, Sun, Wind and Dust (Safety) (Item 34, WP 0105 00)
Life Preserver, Vest (Item 45, WP 0105 00)
Helmet, Safety (Brown) (Item 40, WP 0105 00)
Gloves, Chemical (Item 29, WP 0105 00)
Goggles, Industrial (Chipping, Chemical) (Item 29, WP 0105 00)
Apron, Utility (Item 7, WP 0105 00)
Respirator, Air Filtering (Item 4, WP 0107 00)
Lubricating Gun, Hand (Item 1, WP 0107 00)
Mop, Wet (Item 2, WP 0107 00)
Oiler, Hand (Item 3, WP 0107 00)

Materials/Parts

Antifreeze (Item 2, WP 0106 00)
Cleaner (Item 6, WP 0106 00)
Grease, General Purpose (Item 11, WP 0106 00)
Grease, General Purpose (Molybdenum) (Item 12, WP 0106 00)
Grease, Automotive and Artillery (Item 89 WP 0106 00)
Grease, Aircraft (Item 8, WP 0106 00)
Grease, Ball and Roller Bearing (White Lithium) (Item 10, WP 0106 00)
Grease, Wire Rope-Exposed Gear (Item 13, WP 0106 00)
Fuel, Diesel (Item 7, WP 0106 00)
Lubricating Oil, Gear (Grade 80W90) (Item 16, WP 0106 00)
Lubricating Oil, Engine (Grade 30) (Item 15, WP 0106 00)
Lubricating Oil, Engine (Grade 40) (Item 14, WP 0106 00)
Lubricating Oil, (Item 18, WP 0106 00)
Lubricating Oil, General Purpose (DTE-25) (Hydraulic Fluid) (Item 17, WP 0106 00)
Water, Reagent Distilled (Item 20, WP 0106 00)
Rag, Wiping (Item 19, WP 0106 00)

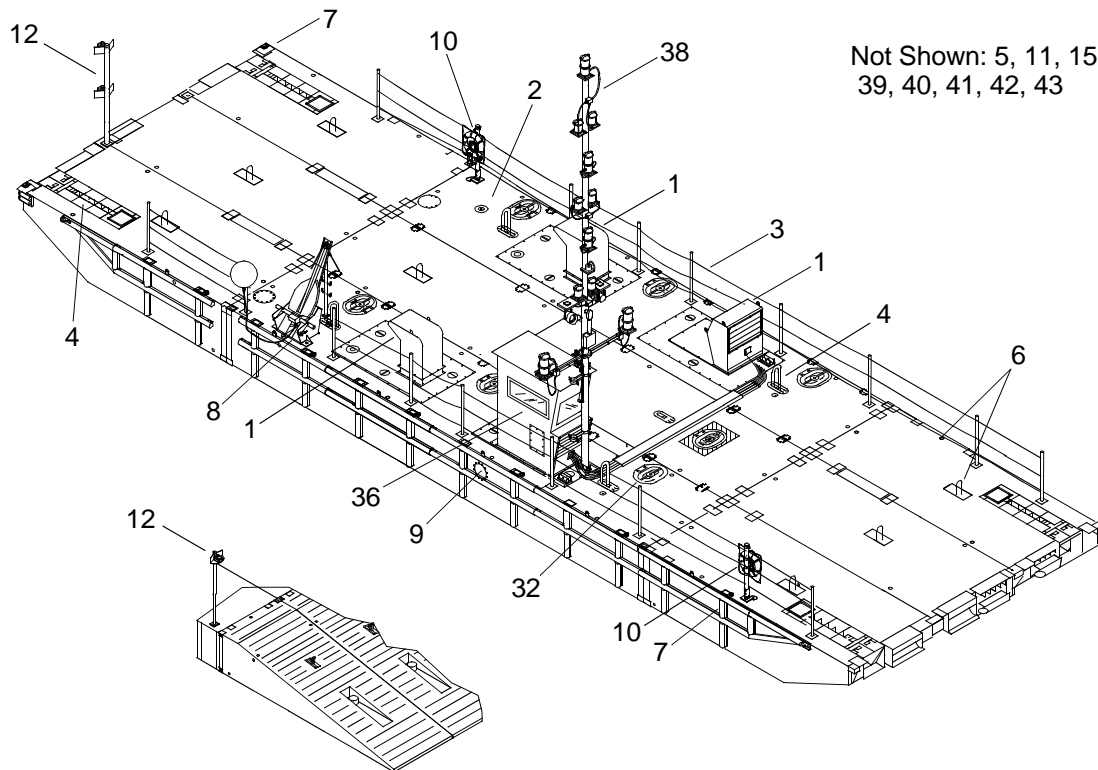
Personnel Required

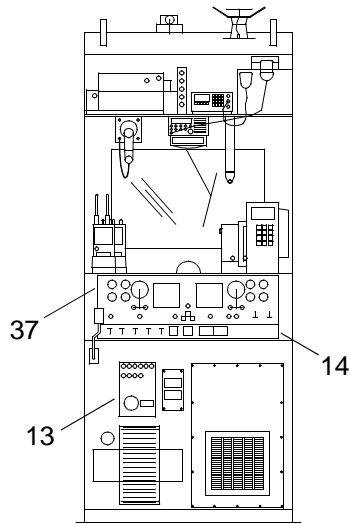
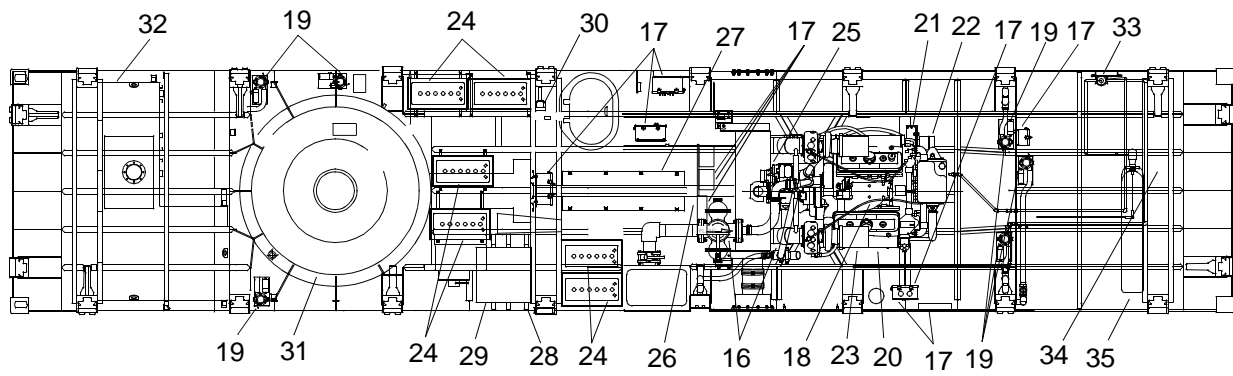
Seaman 88K
Engineer 88L

References

DA PAM 738-750
29 CFR
46 CFR

- | | |
|--|---|
| 1. Intake and Exhaust Plenums | 22. Diesel Engine Cooling System |
| 2. Powered and Non-Powered Modules | 23. Diesel Engine Air System |
| 3. Railing Assembly | 24. Batteries |
| 4. Flexors | 25. Marine Gear |
| 5. Rhino Horn | 26. Transfer Case |
| 6. Lift Shackles and Deck Fittings | 27. Drive Shafts |
| 7. Fenders | 28. Hydraulic System |
| 8. Anchorboard Assembly | 29. Hydraulic Reservoir |
| 9. Exhaust Flapper Valve | 30. Emergency Steering Hand Pump |
| 10. Life Ring Strobe Light | 31. Pump-Jet |
| 11. Main Mast Winch | 32. Fuel System |
| 12. Stub / Bow Mast Lights | 33. Bilge Pump System (Lazaret) |
| 13. Cab Circuit Breaker Panel | 34. Emergency Steering Control Stand |
| 14. Cab Lower Control Panel | 35. Fire Suppression System |
| 15. Ventilation Fan | 36. Operators Cab |
| 16. Bilge Pump System Compartment | 37. Middle Control Panel |
| 17. Electrical Junction and Terminal Boxes | 38. Navigation Masts and Lights |
| 18. Raw Water Cooling System | 39. Powered Section |
| 19. Bilge Pumps | 40. Slings |
| 20. Diesel Engine | 41. Weight Lifting Devices |
| 21. Diesel Engine Alternator | 42. Module Interlock Connector and Spring |
| | 43. Horizontal and Vertical Connectors |

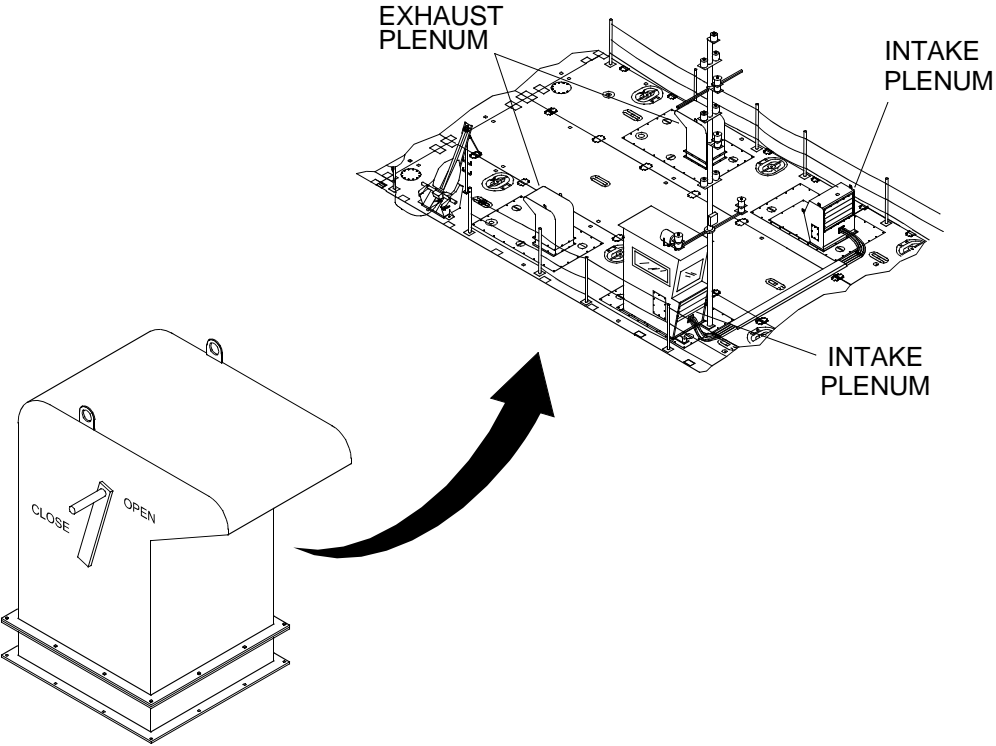




■ **Table 1. Preventive Maintenance Checks and Services for the Causeway Ferry.**

ITEM NO.	INTERVAL	MAN-HOURS	ITEM TO BE CHECKED OR SERVICED	PROCEDURE	EQUIPMENT NOT READY/ AVAILABLE IF:
1	Before	0.05	Intake and Exhaust Plenums	<p>1. Ensure plenums are secured to deck. If plenums are loose, attach plenums to deck.</p> <p>2. Check electrical interconnection cable for secure attachment to intake plenum. If cable connections are disconnected or loose, connect or tighten cables.</p> <p>3. Check that exhaust fan power cables are connected. Connect cables if disconnected.</p> <p>4. Check that exhaust plenum door handles are in the OPEN position. If handles are in the CLOSED position, move handles to the OPEN position.</p> <p>5. Check for loose hardware. If found, contact unit maintenance.</p> <p>6. Inspect portable fire extinguisher for discharge nozzle obstruction, proper mounting, tag signed within the last month and that all seals and pins are in place. Record completion of the inspection in the deck logbook. If discharge nozzle is obstructed, fire extinguisher mounting is loose, tag is not signed within the last month or seals or pins are missing, contact unit maintenance.</p>	

Table 1. Preventive Maintenance Checks and Services for the Causeway Ferry. (Continued)

ITEM NO.	INTERVAL	MAN-HOURS	ITEM TO BE CHECKED OR SERVICED	PROCEDURE	EQUIPMENT NOT READY/ AVAILABLE IF:
1	Before	0.05	Intake and Exhaust Plenums (Cont'd)		
2	Before	0.1	Powered and Non-Powered Modules	<p>1. Ensure all soft patches are secured for sea operation, including exhaust port patches (opposite exhaust port flapper valves). If soft patches are not secure, contact unit maintenance.</p> <p>2. Inspect lazaret, machinery and fuel compartments for indications of water, oil or fuel leaks. Access via personnel hatches. If leaks are found, contact unit maintenance.</p>	Class III oil leakage or Class I fuel leakage is found.

■ Table 1. Preventive Maintenance Checks and Services for the Causeway Ferry. (Continued)

ITEM NO.	INTERVAL	MAN-HOURS	ITEM TO BE CHECKED OR SERVICED	PROCEDURE	EQUIPMENT NOT READY/ AVAILABLE IF:
3	Before	0.1	Railing Assembly	<p>1. Inspect stanchions for broken welds, missing or broken bolts and broken connector. If stanchion welds are broken, bolts are missing or broken or connectors are broken, contact unit maintenance.</p> <p>2. Inspect all cable connecting points on stanchions for proper installation (locked or pinned) to the deck openings. If locks or pins are missing, contact unit maintenance.</p> <p>3. Check all cables and connecting points for worn or frayed areas. If cables or connector points are frayed, contact unit maintenance.</p> <p>4. Check that all cable assemblies are tight. If cables are loose, contact unit maintenance.</p> <p>5. Check all shackles for proper installation to stanchions. Check shackle bolts for tightness.</p>	<p>Stanchions have broken welds, bolts are missing or broken or connecting points are broken.</p> <p>Locks or pins are missing.</p> <p>Shackles have bolts missing or shackles are broken.</p>

CABLE CONNECTING POINTS

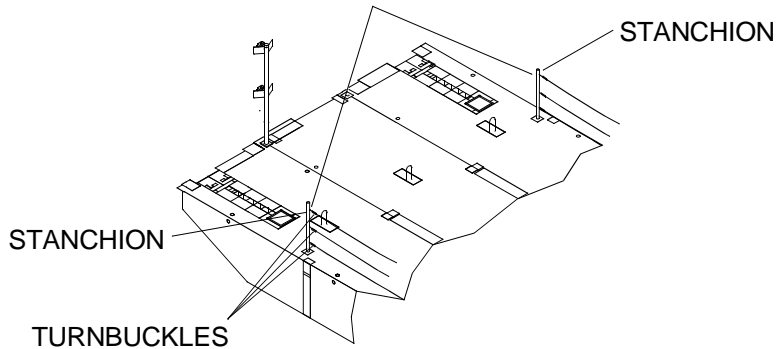
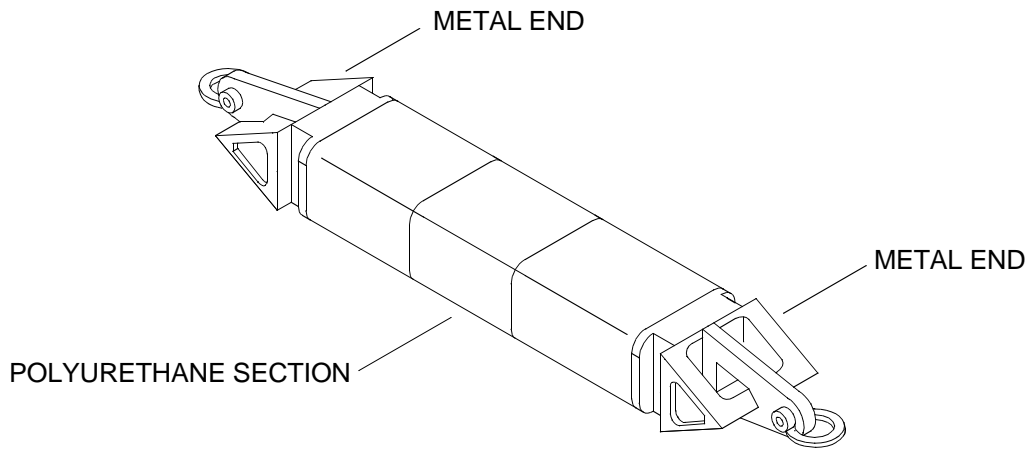


Table 1. Preventive Maintenance Checks and Services for the Causeway Ferry. (Continued)

ITEM NO.	INTERVAL	MAN-HOURS	ITEM TO BE CHECKED OR SERVICED	PROCEDURE	EQUIPMENT NOT READY/ AVAILABLE IF:
4	Before	0.5	Flexors	<p>1. Inspect uninstalled flexors for separation of the polyurethane material in the center. If separation of the polyurethane material in the center of the flexor is found, contact unit maintenance.</p> <p>2. Inspect uninstalled flexors for cracks in the external weldments on the ends. If cracks in the external weldments on the ends of the flexor are found, contact unit maintenance.</p>	



5	Before	0.05	Rhino Horn	<p>Inspect for damage or cracks, missing parts, corrosion or broken welds. If damage, cracks, corrosion or broken welds are found or parts are missing, contact unit maintenance.</p>	
---	--------	------	------------	---	--

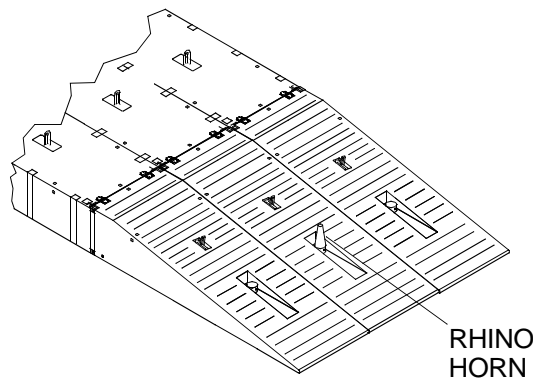
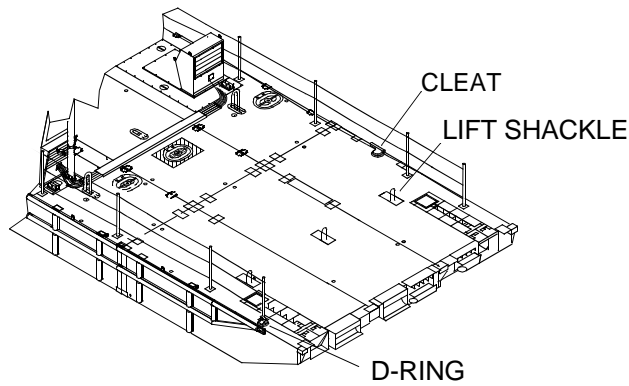


Table 1. Preventive Maintenance Checks and Services for the Causeway Ferry. (Continued)

ITEM NO.	INTERVAL	MAN-HOURS	ITEM TO BE CHECKED OR SERVICED	PROCEDURE	EQUIPMENT NOT READY/ AVAILABLE IF:
6	Before	0.05 0.1	Lift Shackles Deck Fittings	Remove water from lift shackle padeyes. Inspect D-rings/cloverleaf fittings and deck cleats for corrosion, breakage or missing parts. If corrosion is found or D-rings/cloverleaf fittings or deck cleats are broken or have missing parts, contact unit maintenance.	



7	Before	0.2	Fenders	Inspect fenders for damage that would prevent proper operation of the fenders. If damage is found that would prevent proper operation of the fenders, contact unit maintenance.	T-bolts, nuts missing. Rubber missing.
---	--------	-----	---------	---	--

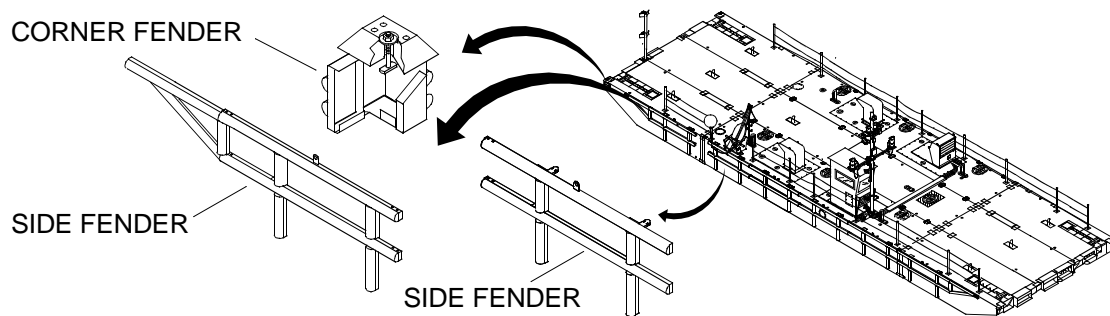
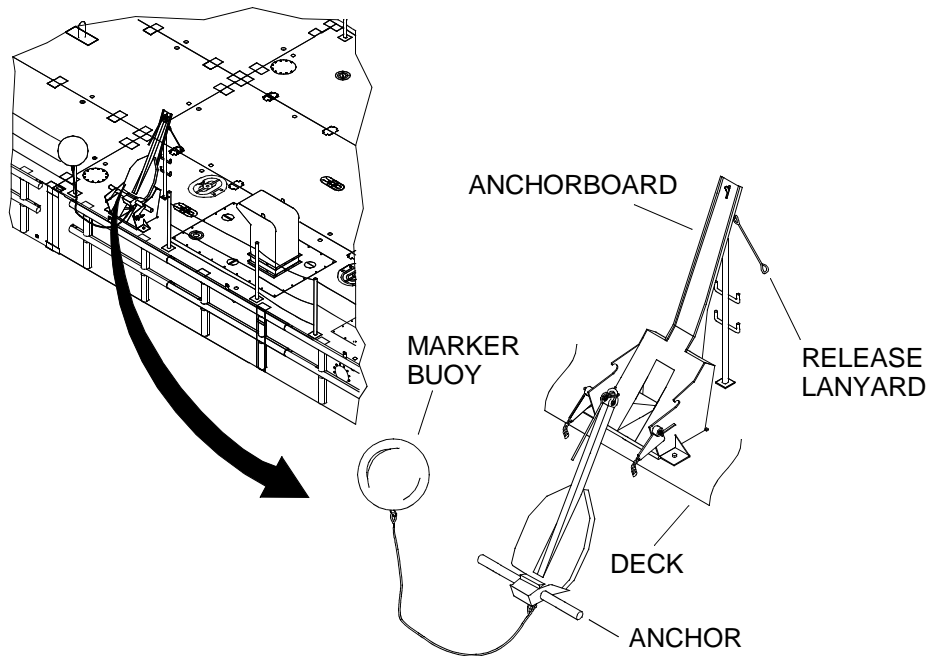


Table 1. Preventive Maintenance Checks and Services for the Causeway Ferry. (Continued)

ITEM NO.	INTERVAL	MAN-HOURS	ITEM TO BE CHECKED OR SERVICED	PROCEDURE	EQUIPMENT NOT READY/ AVAILABLE IF:
8	Before	0.1	Anchorboard Assembly	Inspect for wear, broken welds, corrosion or warpage. If wear, broken welds, corrosion or warpage is found, contact unit maintenance.	



9	Before	0.1	Exhaust Flapper Valves	Open exhaust flapper valves on port and starboard modules.	
---	--------	-----	------------------------	--	--

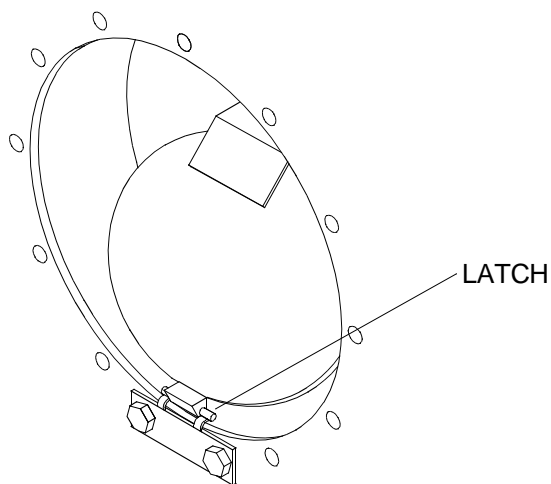


Table 1. Preventive Maintenance Checks and Services for the Causeway Ferry. (Continued)

ITEM NO.	INTERVAL	MAN-HOURS	ITEM TO BE CHECKED OR SERVICED	PROCEDURE	EQUIPMENT NOT READY/ AVAILABLE IF:
17	Before	0.1	Electrical Junction and Terminal Boxes	Switch Multi-battery High Current Solenoid to the ON (closed) position. If green indicator light does not illuminate and an audible click is not heard, contact unit maintenance.	Multi-Battery Isolator High Current Solenoid does not function.

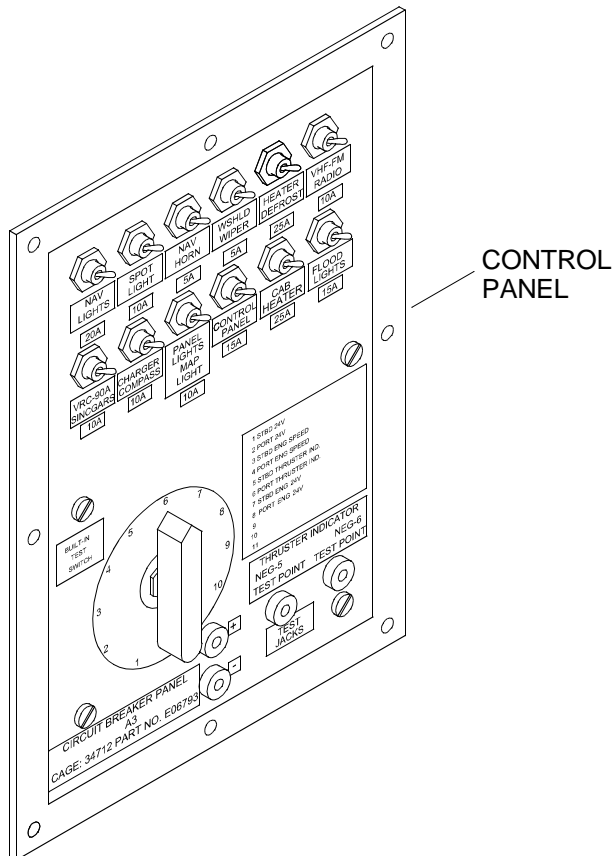
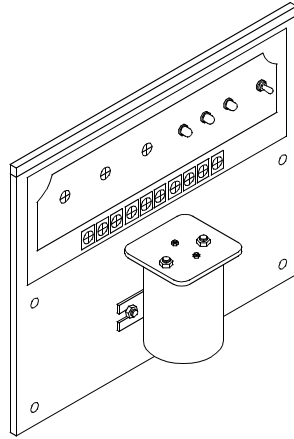


Table 1. Preventive Maintenance Checks and Services for the Causeway Ferry. (Continued)

ITEM NO.	INTERVAL	MAN-HOURS	ITEM TO BE CHECKED OR SERVICED	PROCEDURE	EQUIPMENT NOT READY/ AVAILABLE IF:
14	Before	0.1	Cab Lower Control Panel	1. Switch VENT FANS toggle switches port and stbd to ON position. green indicator lights come on. If green lights do not come on, contact unit maintenance. 2. Verify that vent fans are working. If fans do not operate, contact unit maintenance.	

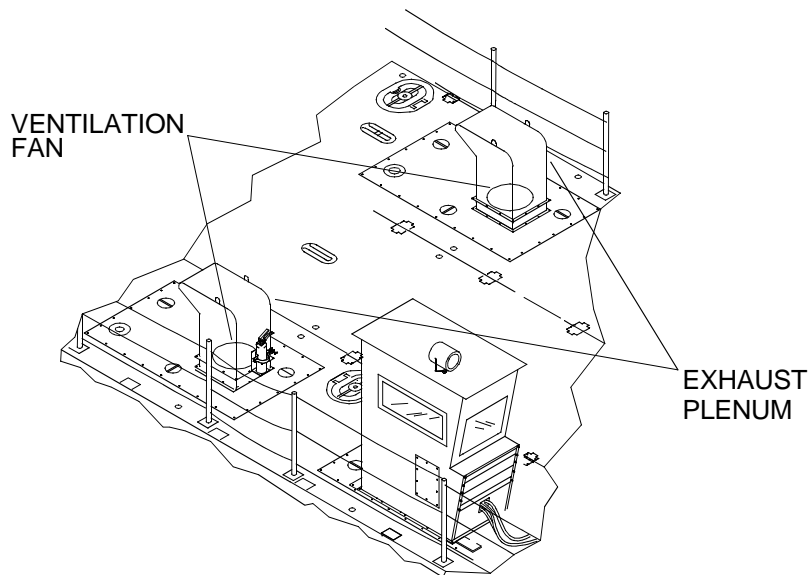
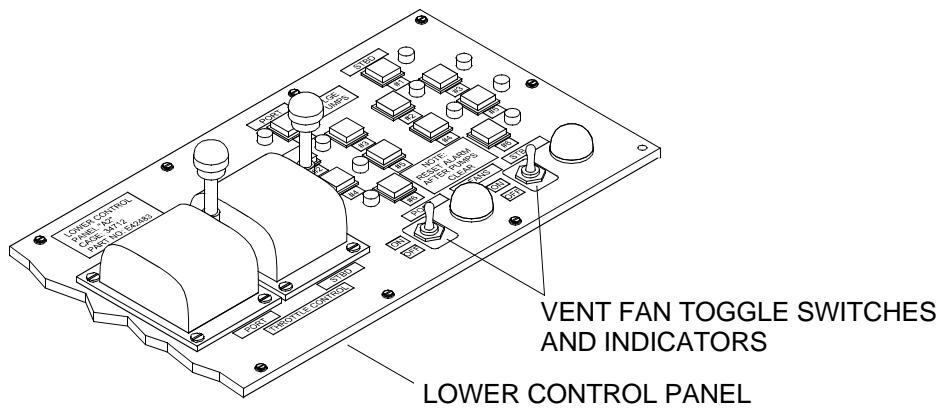


Table 1. Preventive Maintenance Checks and Services for the Causeway Ferry. (Continued)

ITEM NO.	INTERVAL	MAN-HOURS	ITEM TO BE CHECKED OR SERVICED	PROCEDURE	EQUIPMENT NOT READY/ AVAILABLE IF:
33	Before	0.3	Bilge Pump System Compartment	1. Inspect compartment for evidence of water, oil or fuel leaks. If leaks are found, contact unit maintenance.	Evidence of Class III leakage of water or oil. Evidence of Class I leakage of fuel.

NOTE

Do not pump bilges overboard. Pump bilges into holding tank. If holding tank is full, take vessel to sludge point.

2. If only water is present as indicated by the red flood light(s) on the operators cab control console, activate bilge pumps by pushing adjacent bilge pump push buttons. Once water is removed, the bilge pump(s) will automatically stop. If bilge pumps are inoperative, contact unit maintenance.

3. Test pumps by momentarily holding toggle switch(s) in TEST position and listening for pump operation. Switches will spring-return to the REMOTE position. If bilge pumps are inoperative, contact unit maintenance.

REMOTE POSITION

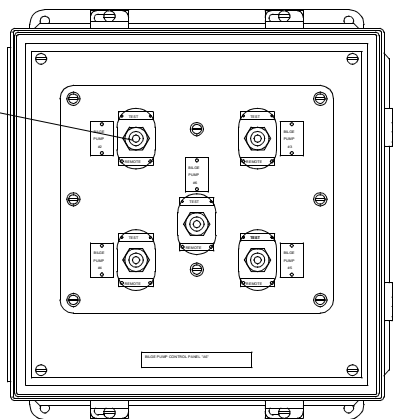
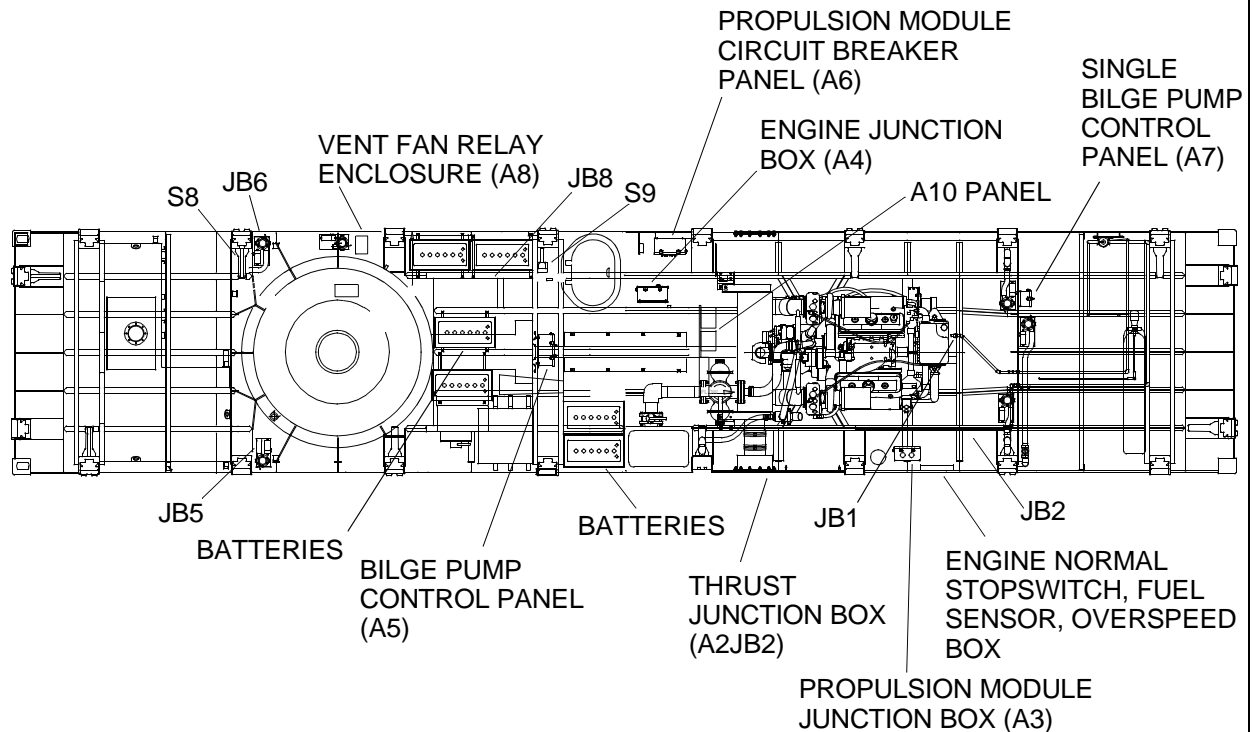


Table 1. Preventive Maintenance Checks and Services for the Causeway Ferry. (Continued)

ITEM NO.	INTERVAL	MAN-HOURS	ITEM TO BE CHECKED OR SERVICED	PROCEDURE	EQUIPMENT NOT READY/ AVAILABLE IF:
17	Before	0.3	Electrical Junction and Terminal Boxes	<p>1. Inspect electrical wiring for loose connections, dirt and/or damage. If electrical wiring is not securely connected, is damaged or is dirty contact unit maintenance.</p> <p>2. Check all accessible fuse terminal blocks and connections to see that they are securely connected and supported, that insulation is not cracked or chafed and that conduit and shielding are secure and in good condition. If fuse terminal blocks are not securely connected or supported, insulation is cracked or chafed, or conduit and shielding are not secure or damaged, contact unit maintenance.</p>	



■ **Table 1. Preventive Maintenance Checks and Services for the Causeway Ferry. (Continued)**

ITEM NO.	INTERVAL	MAN-HOURS	ITEM TO BE CHECKED OR SERVICED	PROCEDURE	EQUIPMENT NOT READY/ AVAILABLE IF:
18	Before	0.3	Raw Water Cooling System	<ol style="list-style-type: none"> 1. Pull the duplex strainer baskets and clean. 2. Open sea chest butterfly valves, both port and starboard propulsions modules. If valve does not operate, contact unit maintenance. 3. Check the raw water system for leaks. If leaks are found, contact unit maintenance. 4. Verify duplex strainer valve handle is in the extreme left or right position (allowing water to flow through only one of two strainer baskets). If handle will not operate, contact unit maintenance. 5. Verify the exhaust discharge raw water valve lever is in the OPEN position. If valve will not operate, contact unit maintenance. 6. Verify the transfer case oil cooler raw water valve lever is in the OPEN position. If valve will not operate, contact unit maintenance. 7. Inspect the cooling system for leaks or excessive puddling around its base. If leakage is found, contact unit maintenance. 8. In freezing weather (below 32°F): Close all petcocks in the raw water system. Prime the raw water pump. Inspect for leaks after start-up of engine. If leaks are found, contact unit maintenance. 	<p>Class III leakage cannot be located or repaired.</p> <p>Class III leakage is found.</p>

Table 1. Preventive Maintenance Checks and Services for the Causeway Ferry. (Continued)

ITEM NO.	INTERVAL	MAN-HOURS	ITEM TO BE CHECKED OR SERVICED	PROCEDURE	EQUIPMENT NOT READY/ AVAILABLE IF:

Table 1. Preventive Maintenance Checks and Services for the Causeway Ferry. (Continued)

ITEM NO.	INTERVAL	MAN-HOURS	ITEM TO BE CHECKED OR SERVICED	PROCEDURE	EQUIPMENT NOT READY/ AVAILABLE IF:
19	Before	0.2	Bilge Pumps	Check all bilge pumps and float switches for condition and proper operation. Look for evidence of water leaks, loose pump connections and/or damage. If bilge pumps are inoperative, leak, have loose connections, or are damaged, contact unit maintenance.	

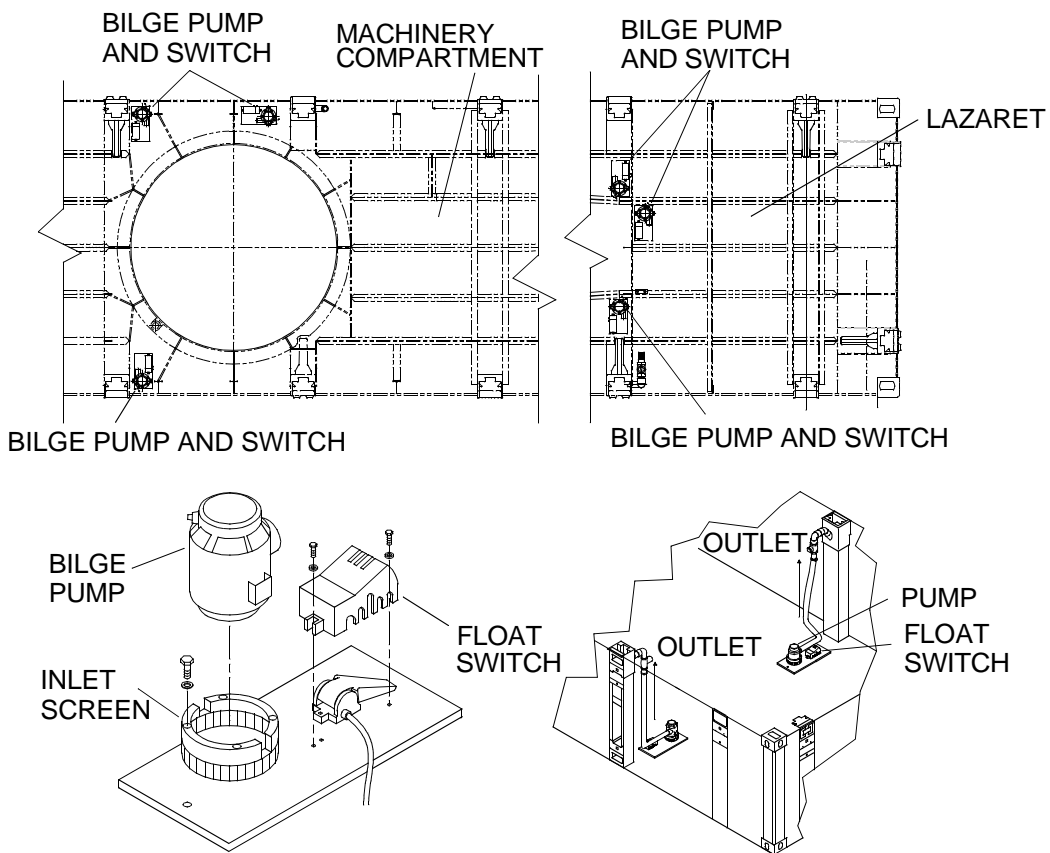


Table 1. Preventive Maintenance Checks and Services for the Causeway Ferry. (Continued)



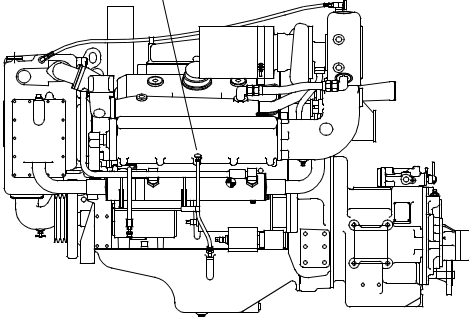
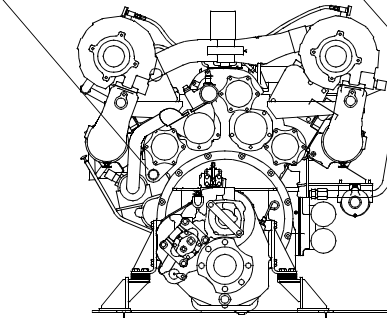
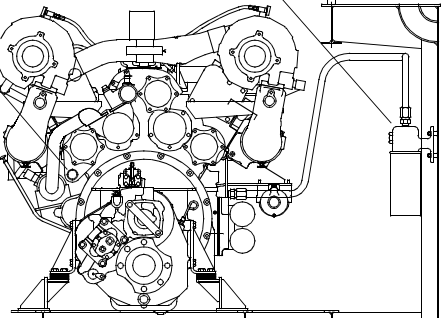
ITEM NO.	INTERVAL	MAN-HOURS	ITEM TO BE CHECKED OR SERVICED	PROCEDURE	EQUIPMENT NOT READY/ AVAILABLE IF:	
<p>WARNING</p> <div style="display: flex; justify-content: space-around; align-items: center;"> <div style="text-align: center;">  <p>CHEMICAL</p> </div> <div style="text-align: center;">  <p>EYE PROTECTION</p> </div> </div>						
20	Before	0.4	Diesel Engine	<p>1. Check the engine oil level. Verify that it registers FULL on the dipstick. Engine must be cool when reading level. If hot, allow to cool for 20 minutes. Add lubricating oil (grade 30). DO NOT OVERFILL.</p> <p>2. Make a visual inspection for oil leaks around the filters and the external oil lines. If leaks are found, contact unit maintenance.</p>	Class III leakage is found.	
<div style="display: flex; justify-content: space-around; align-items: center;"> <div style="text-align: center;"> <p>OIL LEVEL DIPSTICK</p>  </div> <div style="text-align: center;"> <p>ENGINE HOUR METER</p>  </div> <div style="text-align: center;"> <p>OIL FILTER ASSEMBLY</p>  </div> </div>						
				<p>3. Visually inspect the oil. If metal particles are found in it, the oil must be completely changed. Record current engine hour reading and compare with oil change repair records and contact unit maintenance.</p>		

Table 1. Preventive Maintenance Checks and Services for the Causeway Ferry. (Continued)

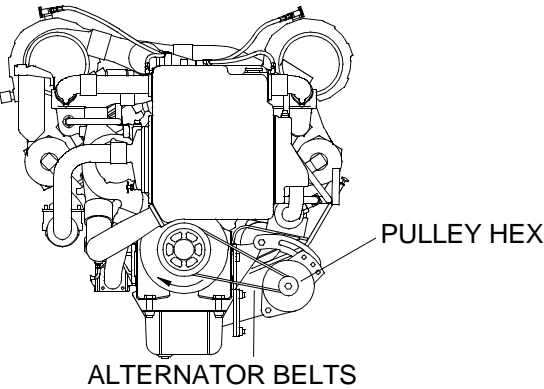




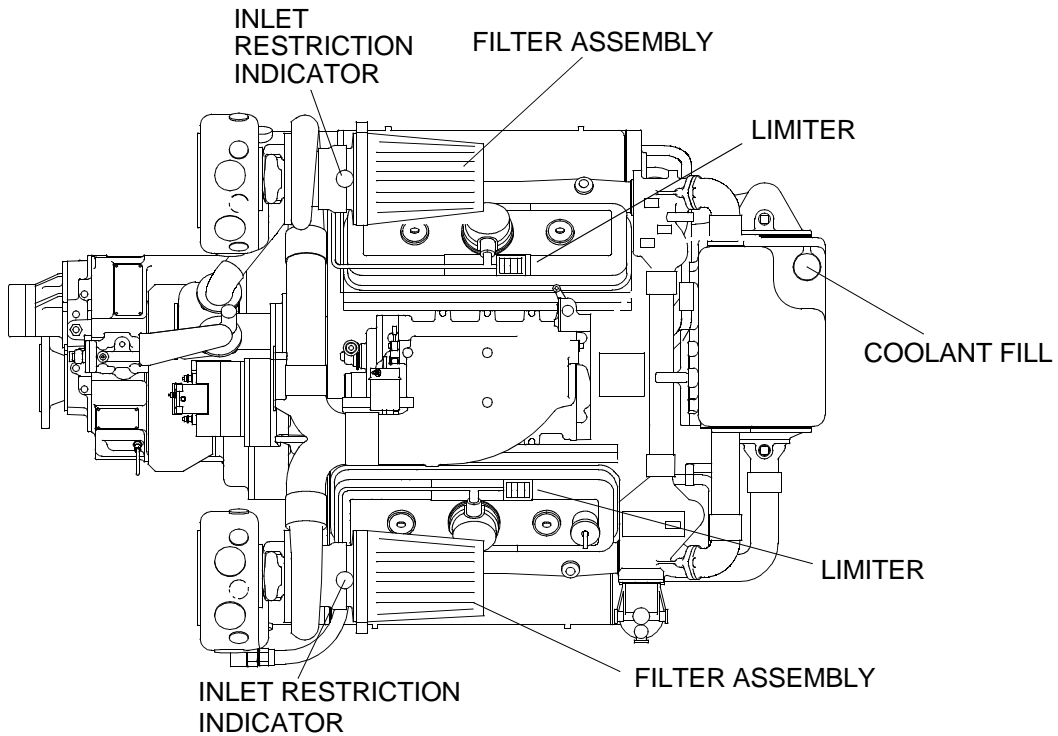
ITEM NO.	INTERVAL	MAN-HOURS	ITEM TO BE CHECKED OR SERVICED	PROCEDURE	EQUIPMENT NOT READY/ AVAILABLE IF:
21	Before	0.1	Diesel Engine Alternator	Check for split, dry-rotted or glazed alternator drive belts. If found, contact unit maintenance. Check belt tension. To check for proper tension with the engine off, use a 15/16 in. socket on the hex of the alternator pulley and try to turn it clockwise. If the pulley turns, the belt can slip. If belt it loose, contact unit maintenance.	Belts are broken or missing.
 <p>PULLEY HEX</p> <p>ALTERNATOR BELTS</p>					
<p>WARNING</p>					
<div style="display: flex; justify-content: space-around; align-items: center;"> <div style="text-align: center;">  <p>HOT AREA</p> </div> <div style="text-align: center;">  <p>CHEMICAL</p> </div> <div style="text-align: center;">  <p>EYE PROTECTION</p> </div> <div style="text-align: center;">  <p>POISON</p> </div> </div>					
22	Before	0.2	Diesel Engine Cooling System	<ol style="list-style-type: none"> 1. Check the engine coolant level. Verify that it is within 1 inch from the top of the heat exchanger, both port and starboard. Add proper coolant mixture as needed. Service with 50/50 water/antifreeze mix. 2. Inspect the air inlet collector assemblies. If the air inlet restriction indicator is red, contact unit maintenance. 	Air inlet restriction indicator is red.

Table 1. Preventive Maintenance Checks and Services for the Causeway Ferry. (Continued)

ITEM NO.	INTERVAL	MAN-HOURS	ITEM TO BE CHECKED OR SERVICED	PROCEDURE	EQUIPMENT NOT READY/ AVAILABLE IF:
22	Before	0.2	Diesel Engine Cooling System (Cont'd)		



3. Verify freshwater filter hand valves are open. If valves will not operate, contact unit maintenance.

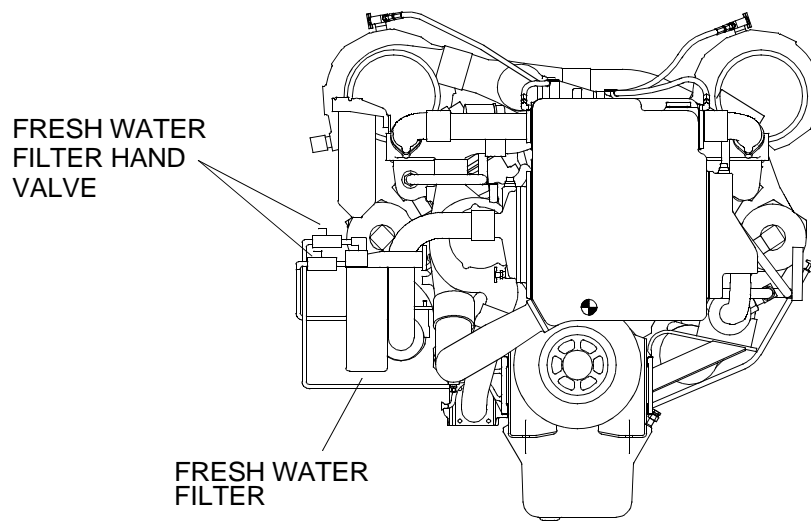


Table 1. Preventive Maintenance Checks and Services for the Causeway Ferry. (Continued)




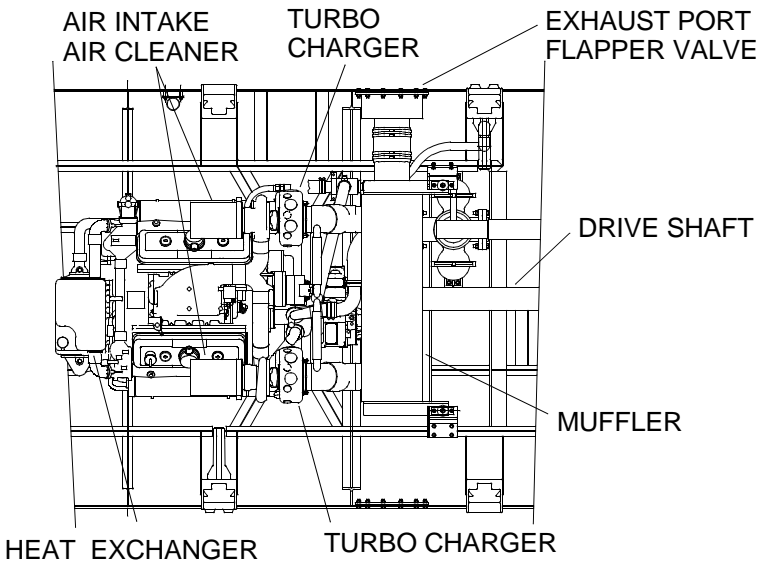


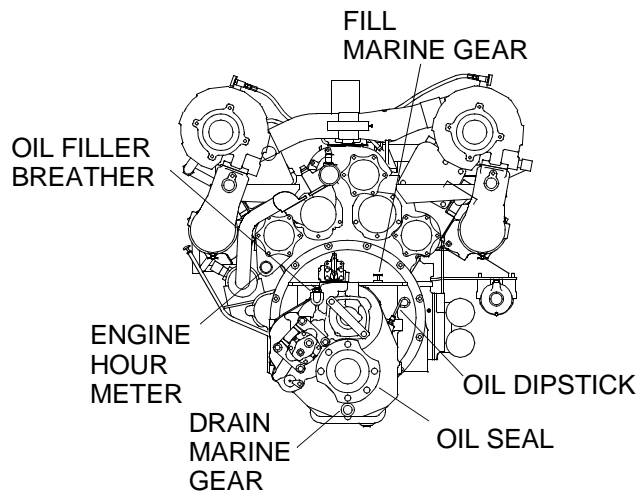
ITEM NO.	INTERVAL	MAN-HOURS	ITEM TO BE CHECKED OR SERVICED	PROCEDURE	EQUIPMENT NOT READY/ AVAILABLE IF:
<p>WARNING</p> <div style="display: flex; justify-content: space-around; align-items: center;"> <div style="text-align: center;">  <p>CHEMICAL</p> </div> <div style="text-align: center;">  <p>EYE PROTECTION</p> </div> <div style="text-align: center;">  <p>EXPLOSION</p> </div> </div>					
23	Before	0.2	Diesel Engine Air System	<p>1. Check the turbochargers and exhaust connections. Visually inspect the mountings, intake and exhaust ducting and connections for leaks. In temperatures below freezing (32°F), check freeze plugs for water leaks. If leaks are found, contact unit maintenance.</p> <p>2. Inspect the engine air filtering system for leaks, torn boots and loose or damaged clamps. If leaks, torn boots or damaged clamps are found, contact unit maintenance.</p>	Evidence of leaks or restrictions are found.
					

Table 1. Preventive Maintenance Checks and Services for the Causeway Ferry. (Continued)

ITEM NO.	INTERVAL	MAN-HOURS	ITEM TO BE CHECKED OR SERVICED	PROCEDURE	EQUIPMENT NOT READY/ AVAILABLE IF:
<p>WARNING</p> <div style="display: flex; justify-content: space-around; align-items: center;"> <div style="text-align: center;">  <p>CHEMICAL</p> </div> <div style="text-align: center;">  <p>EYE PROTECTION</p> </div> </div>					
24	Before	0.3	Batteries	<p>Verify battery electrolyte levels completely cover the plates, without electrolyte overflowing the battery, and that connections are clean and tight, both port and starboard. Add reagent distilled water, if necessary. If connections are loose, batteries are unserviceable or will not start engines, contact unit maintenance.</p>	
25	Before	0.2	Marine Gear	<ol style="list-style-type: none"> 1. Check the oil level in the marine gear. Fill to "F" mark on dipstick with oil. Add lubricating oil (grade 40). 2. Inspect for leaks in the marine gear, particularly near the oil seals. If any leaks are found, contact unit maintenance. 3. Read engine hours and record in logbook. 	Class III leakage is found.



■ Table 1. Preventive Maintenance Checks and Services for the Causeway Ferry. (Continued)



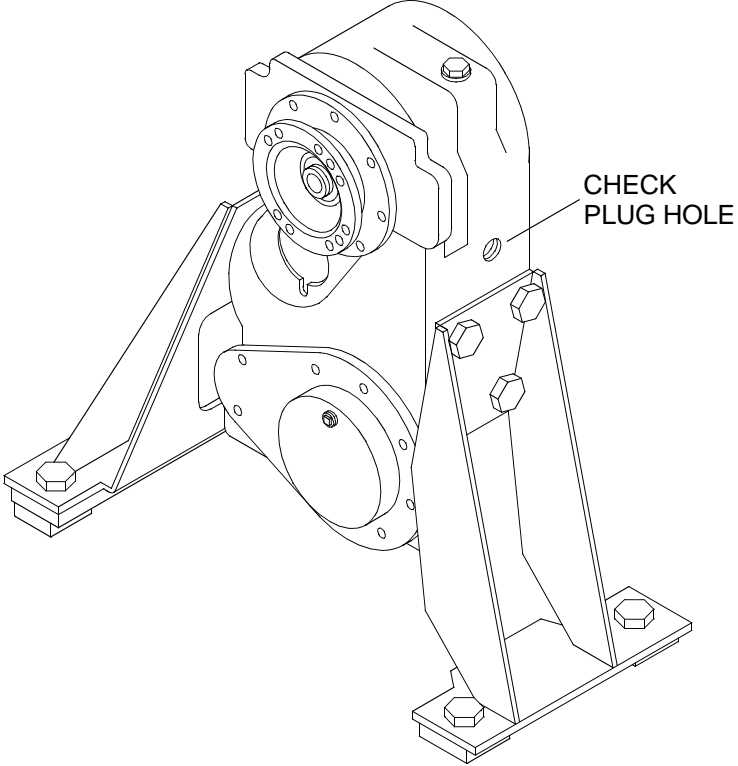
ITEM NO.	INTERVAL	MAN-HOURS	ITEM TO BE CHECKED OR SERVICED	PROCEDURE	EQUIPMENT NOT READY/ AVAILABLE IF:
<p>WARNING</p> <div style="display: flex; justify-content: space-around; align-items: center;"> <div style="text-align: center;">  <p>CHEMICAL</p> </div> <div style="text-align: center;">  <p>EYE PROTECTION</p> </div> </div>					
26	Before	0.2	Transfer Case	<p>Check oil level in transfer case. Oil should be present at bottom of check plug hole. Service with lubricating oil (grade 30). DO NOT OVERFILL.</p>	
					

Table 1. Preventive Maintenance Checks and Services for the Causeway Ferry. (Continued)

ITEM NO.	INTERVAL	MAN-HOURS	ITEM TO BE CHECKED OR SERVICED	PROCEDURE	EQUIPMENT NOT READY/ AVAILABLE IF:
27	Before	0.1	Drive Shafts	Inspect drive shafts between marine gear and transfer case and between pump-jet and transfer case. Inspect for physical damage or degradation. If damage or degradation is found, contact unit maintenance.	

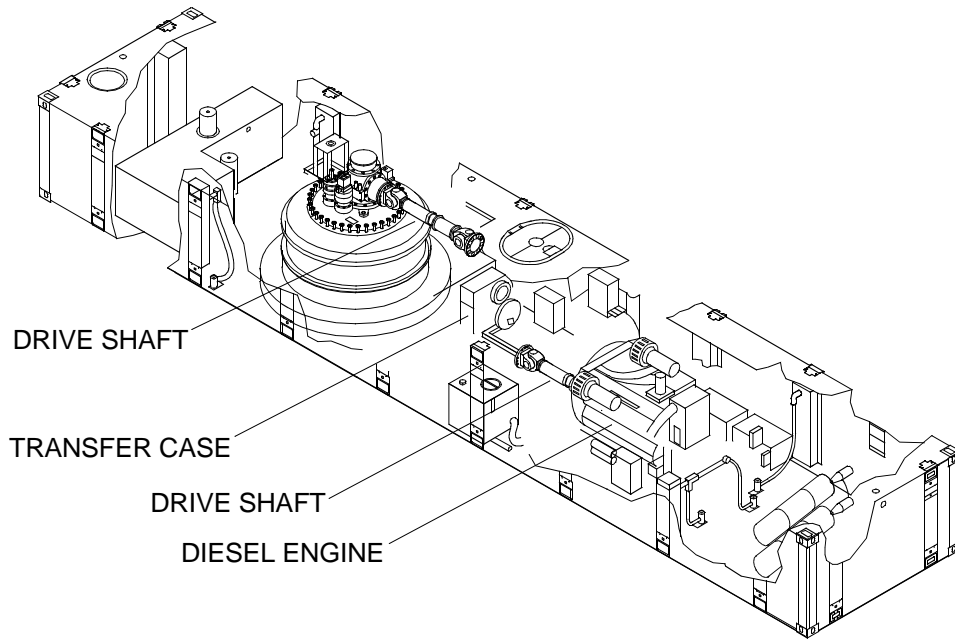
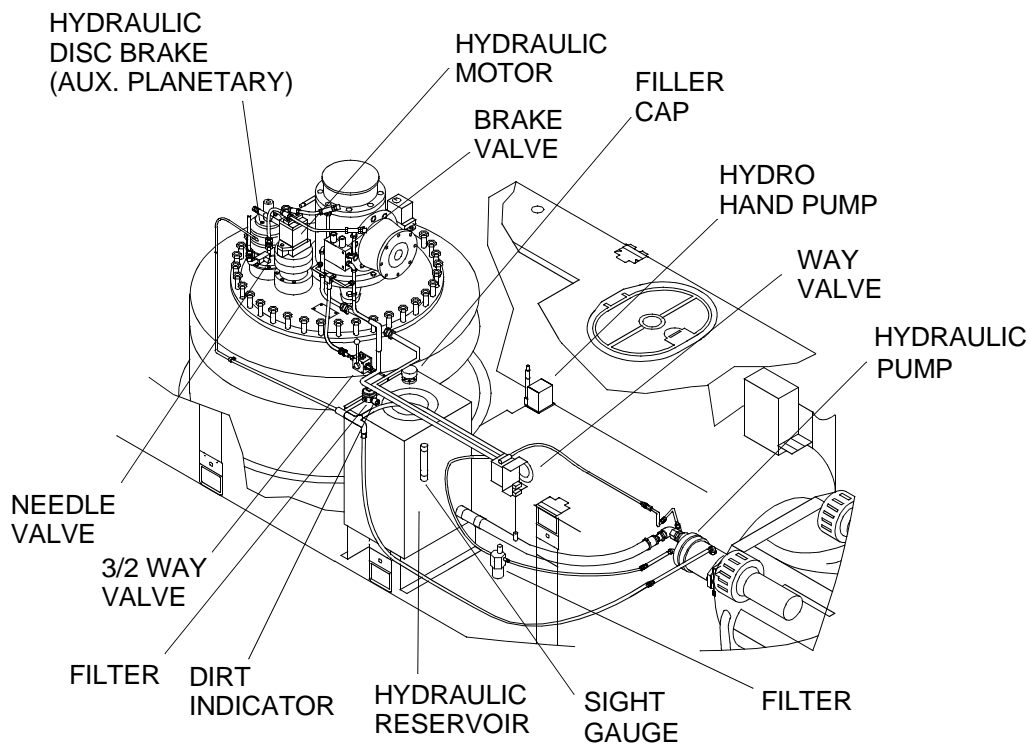


Table 1. Preventive Maintenance Checks and Services for the Causeway Ferry. (Continued)

ITEM NO.	INTERVAL	MAN-HOURS	ITEM TO BE CHECKED OR SERVICED	PROCEDURE	EQUIPMENT NOT READY/ AVAILABLE IF:
28	Before	0.1	Hydraulic System	Inspect all hydraulic components, including way valve assembly, hydraulic pump, hydraulic reservoir, hand pump and pump-jet main and auxiliary planetary gear housings for evidence of hydraulic fluid leakage. If hydraulic leakage is found, contact unit maintenance.	Class III hydraulic leakage is found.



WARNING





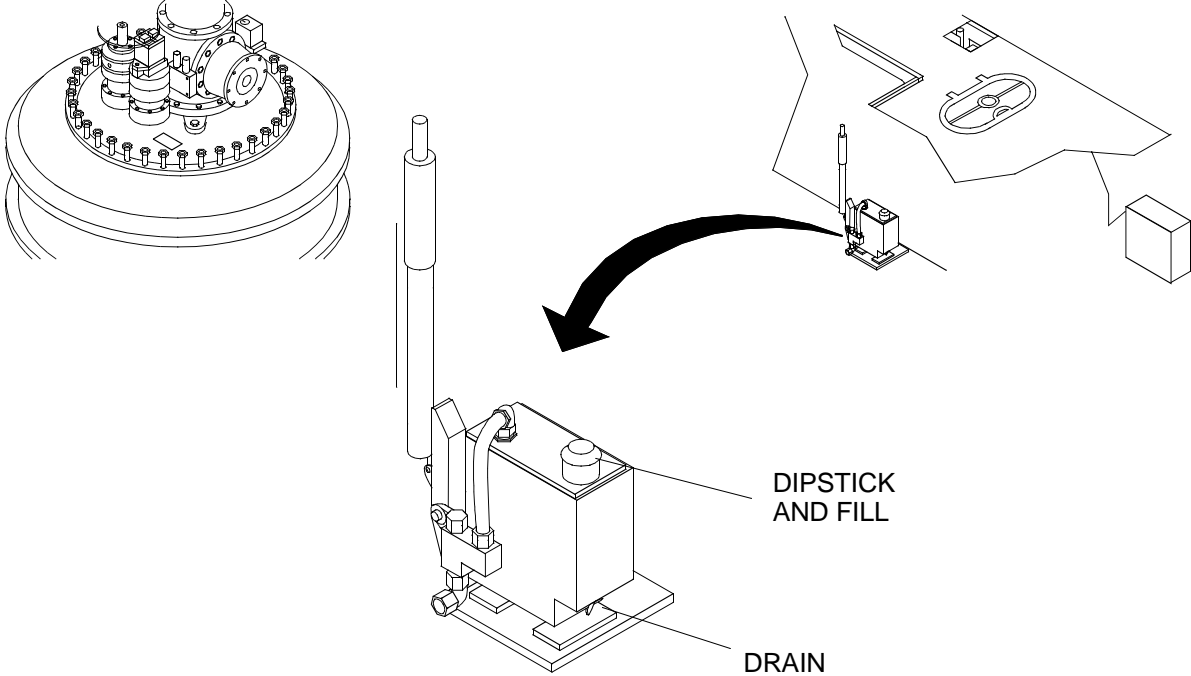
EYE PROTECTION



CHEMICAL

29	Before	0.1	Hydraulic Reservoir	Check that reservoir fluid level is more than 1/2 full but less than 3/4 full in the sight gage. Add lubricating oil (DTE-25). Contact unit maintenance if leakage is found.	
----	--------	-----	---------------------	--	--

Table 1. Preventive Maintenance Checks and Services for the Causeway Ferry. (Continued)

ITEM NO.	INTERVAL	MAN-HOURS	ITEM TO BE CHECKED OR SERVICED	PROCEDURE	EQUIPMENT NOT READY/ AVAILABLE IF:
<p>WARNING</p> <div style="display: flex; justify-content: space-around; align-items: center;"> <div style="text-align: center;">  <p>EYE PROTECTION</p> </div> <div style="text-align: center;">  <p>VAPOR</p> </div> </div>					
30	Before	0.1	Emergency Steering Hand Pump	Turn and pull out dipstick and ensure oil level is at FULL mark. Add lubricating oil (DTE-25). Contact unit maintenance if leakage is found.	
					

■ Table 1. Preventive Maintenance Checks and Services for the Causeway Ferry. (Continued)



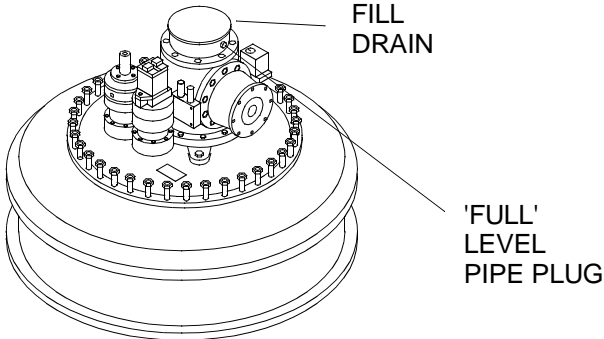
ITEM NO.	INTERVAL	MAN-HOURS	ITEM TO BE CHECKED OR SERVICED	PROCEDURE	EQUIPMENT NOT READY/ AVAILABLE IF:
<p>WARNING</p> <div style="display: flex; justify-content: space-around; align-items: center;"> <div style="text-align: center;">  <p>CHEMICAL</p> </div> <div style="text-align: center;">  <p>EYE PROTECTION</p> </div> </div>					
31	Before	0.1	Pump-Jet	<p>1. Check oil level of pump-jet is at the level of the pipe plug at the forward (nearest drive shaft), top of pump-jet in cold condition. Add lube oil as necessary. Service with lubricating oil. DO NOT OVERFILL. If oil leakage is found, contact unit maintenance.</p> <p>2. Check the expansion tank for leaks and loose mounting. If leaks or loose mounting is found, contact unit maintenance.</p>	<p>Class III hydraulic leakage is found.</p> <p>Class III hydraulic leakage is found.</p>
 <p>PUMP-JET SHOWN WITH COVER REMOVED</p>					

Table 1. Preventive Maintenance Checks and Services for the Causeway Ferry. (Continued)




ITEM NO.	INTERVAL	MAN-HOURS	ITEM TO BE CHECKED OR SERVICED	PROCEDURE	EQUIPMENT NOT READY/ AVAILABLE IF:
<p>WARNING</p> <div style="display: flex; justify-content: space-around; align-items: center;"> <div style="text-align: center;">  <p>EXPLOSION</p> </div> <div style="text-align: center;">  <p>FIRE</p> </div> <div style="text-align: center;">  <p>VAPOR</p> </div> </div> <p>Use approved procedures when cleaning up fuel spills. Take proper precautions when removing or installing any fuel system component. Failure to comply may result in serious injury to death to personnel.</p>					
32	Before	0.3	Fuel System	<ol style="list-style-type: none"> 1. Check for leaks around fuel tank and fuel lines. If leaks are found, contact unit maintenance. 2. Examine fuel lines and flexible hoses for leaks. Check that fittings, clamps and tiedown straps are secure. Hoses must not be resting or touching shafts, couplings, heated surfaces, sharp edges, or other areas that might sever or rupture fuel system parts. If leaks, loose fittings, clamps or tiedown straps are found or hoses are resting on shafts, couplings, heated surfaces, sharp edges, or other areas that might sever or rupture fuel system parts, contact unit maintenance. 	<p>Class I fuel leakage is found.</p> <p>Class I fuel leakage is found.</p>

Table 1. Preventive Maintenance Checks and Services for the Causeway Ferry. (Continued)





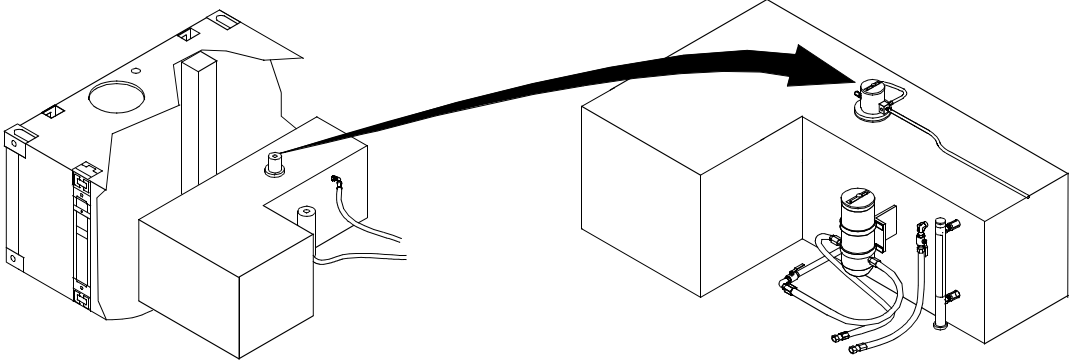




ITEM NO.	INTERVAL	MAN-HOURS	ITEM TO BE CHECKED OR SERVICED	PROCEDURE	EQUIPMENT NOT READY/ AVAILABLE IF:
<p>WARNING</p> <div style="display: flex; justify-content: space-around; align-items: center;"> <div style="text-align: center;">  CHEMICAL </div> <div style="text-align: center;">  EYE PROTECTION </div> <div style="text-align: center;">  EXPLOSION </div> <div style="text-align: center;">  FIRE </div> </div>					
32	Before	0.3	Fuel System (Cont'd)	<p>3. Verify fuel tank is full by checking tank fuel indicator or using a fuel stick. If necessary, add fuel. DO NOT OVER FILL. Service with diesel fuel. If tank fuel level indicator is cracked or broken or if fuel leaks are found, contact unit maintenance.</p>	Broken fuel level indicator or Class I fuel leakage.
					
<p>WARNING</p> <div style="display: flex; justify-content: space-around; align-items: center;"> <div style="text-align: center;">  CHEMICAL </div> <div style="text-align: center;">  EYE PROTECTION </div> <div style="text-align: center;">  EXPLOSION </div> <div style="text-align: center;">  FIRE </div> </div>					
				<p>4. Open the fuel supply line ball valve.</p> <p>5. Open the fuel return line ball valve.</p>	

Table 1. Preventive Maintenance Checks and Services for the Causeway Ferry. (Continued)

ITEM NO.	INTERVAL	MAN-HOURS	ITEM TO BE CHECKED OR SERVICED	PROCEDURE	EQUIPMENT NOT READY/ AVAILABLE IF:
32	Before	0.3	Fuel System (Cont'd)	6. Visually inspect and drain water and/or other contaminants from fuel/water separator into a drain pan. When pure fuel emerges, close drain. Dispose of fuel in accordance with local procedures. If fuel/water separator glass bowl is broken or tank has an excessive amount of water, contact unit maintenance.	Broken fuel/water separator or water in fuel prevents engine from starting.

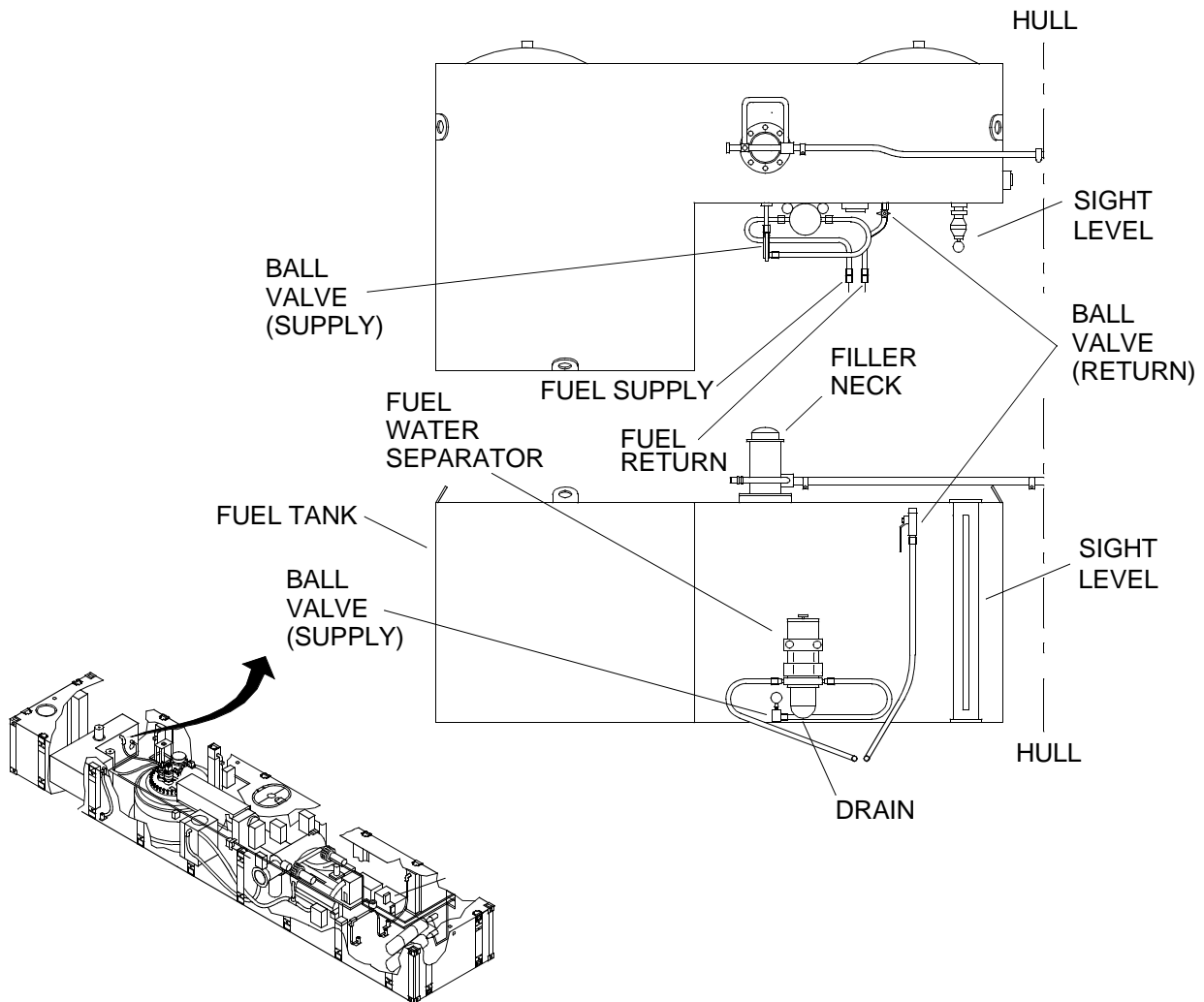


Table 1. Preventive Maintenance Checks and Services for the Causeway Ferry. (Continued)

ITEM NO.	INTERVAL	MAN-HOURS	ITEM TO BE CHECKED OR SERVICED	PROCEDURE	EQUIPMENT NOT READY/ AVAILABLE IF:
33	Before	0.3	Bilge Pump System (Lazaret)	1. Check compartment for evidence of water and leaks. If leaks are found, contact unit maintenance.	
<p>NOTE</p> <p>Do not pump bilges overboard. Pump bilges into holding tank. If holding tank is full, take vessel to sludge point.</p> <p>2. If water is present, activate bilge pump, as indicated by red flood location light on the operators cab control console in the operators cab, by pushing the adjacent bilge pump push button. Once water is removed, the bilge pump will automatically stop. If pumps are inoperative, contact unit maintenance.</p> <p>3. Test pump by momentarily holding toggle switch in the TEST position and listening for pump operation. Switch will spring-return to the REMOTE position. If pumps are inoperative, contact unit maintenance.</p> <p>4. Clean debris from the float switch and bilge pump suction inlet screen. Wipe clean all bilges.</p>					

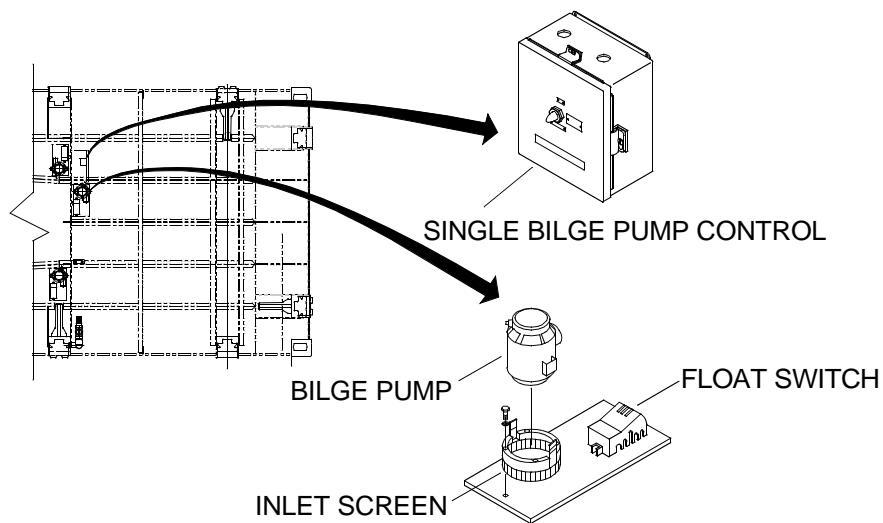
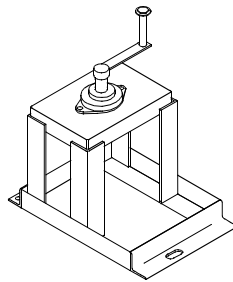


Table 1. Preventive Maintenance Checks and Services for the Causeway Ferry. (Continued)

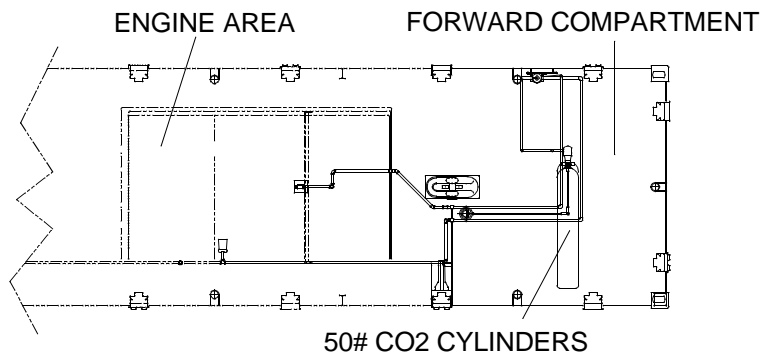
ITEM NO.	INTERVAL	MAN-HOURS	ITEM TO BE CHECKED OR SERVICED	PROCEDURE	EQUIPMENT NOT READY/ AVAILABLE IF:
34	Before	0.1	Emergency Steering Control Stand (stowed in lazaret)	Visually inspect control stand for obvious damage, evidence of corrosion, wear and loose or missing parts. If control stand is damaged, corroded or has loose or missing parts, contact unit maintenance.	Control stand is inoperative.



WARNING

Use extreme care when inspecting or servicing CO2. Failure to comply could result in injury or death.

35	Before	0.1	Fire Suppression System	Inspect for discharge, leakage or expansion. Look for damaged or broken seals. If discharge, leakage, expansion, damaged or broken are found, contact unit maintenance.	Seals are damaged or broken, or evidence of excessive discharge is found.
----	--------	-----	-------------------------	---	---



■ **Table 1. Preventive Maintenance Checks and Services for the Causeway Ferry. (Continued)**

ITEM NO.	INTERVAL	MAN-HOURS	ITEM TO BE CHECKED OR SERVICED	PROCEDURE	EQUIPMENT NOT READY/ AVAILABLE IF:
36	Before	0.3	Operators Cab	<p>1. Check operator cab structure for damage to mountings. If damage is found, contact unit maintenance.</p> <p>2. Visually inspect cab mounted antennas, spotlight, bell, horn, and mast sheaves for damage that would prevent operation. If damage is found that would prevent operation, contact unit maintenance.</p> <p>3. Functionally check folding steps. If folding steps do not function properly, contact unit maintenance.</p> <p>3. Functionally check windshield wiper. If windshield wiper is inoperative, contact unit maintenance.</p> <p>4. Functionally check spotlight. If spotlight is inoperative, contact unit maintenance.</p> <p>5. Functionally test battle lantern. If battle lantern is inoperative, contact unit maintenance.</p> <p>6. Functionally check VHF/FM DSC transceiver. If VHF/FM DSC transceiver is inoperative, contact unit maintenance.</p> <p>7. Functionally check loudhailer. If loudhailer is inoperative, contact unit maintenance.</p> <p>8. Functionally check Precision Lightweight Global Positioning Receiver (PLGR). If PLGR is inoperative, contact unit maintenance.</p>	<p>VHF/FM DSC transceiver is inoperative. VHF/FM DSC transceiver is a safety requirement and must be operational.</p>

Table 1. Preventive Maintenance Checks and Services for the Causeway Ferry. (Continued)

ITEM NO.	INTERVAL	MAN-HOURS	ITEM TO BE CHECKED OR SERVICED	PROCEDURE	EQUIPMENT NOT READY/ AVAILABLE IF:
36	Before	0.3	Operators Cab (Cont'd)	<p>9. Functionally check VHF/FM handheld transceivers and battery chargers. If transceivers or battery chargers are inoperative, contact unit maintenance.</p> <p>10. Functionally check SINGGARS radio. If SINGGARS radio is inoperative, contact unit maintenance.</p> <p>11. Inspect all radio antennae, handsets, cables and batteries. If damage is found that would prevent operation, contact unit maintenance.</p>	

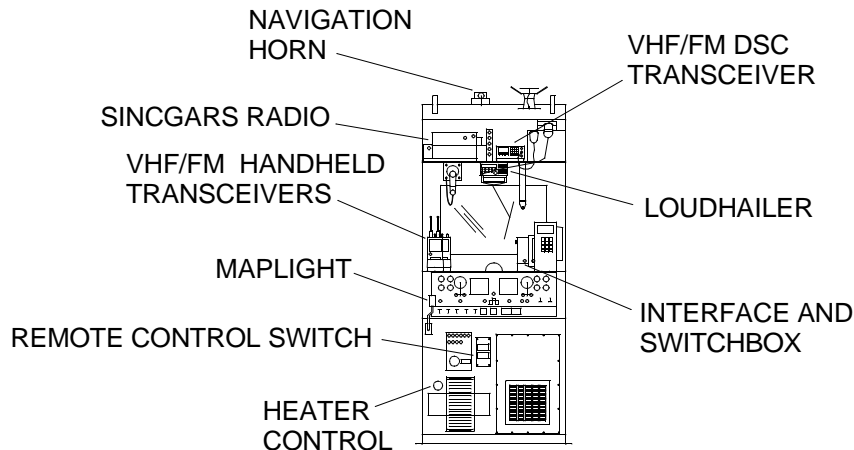
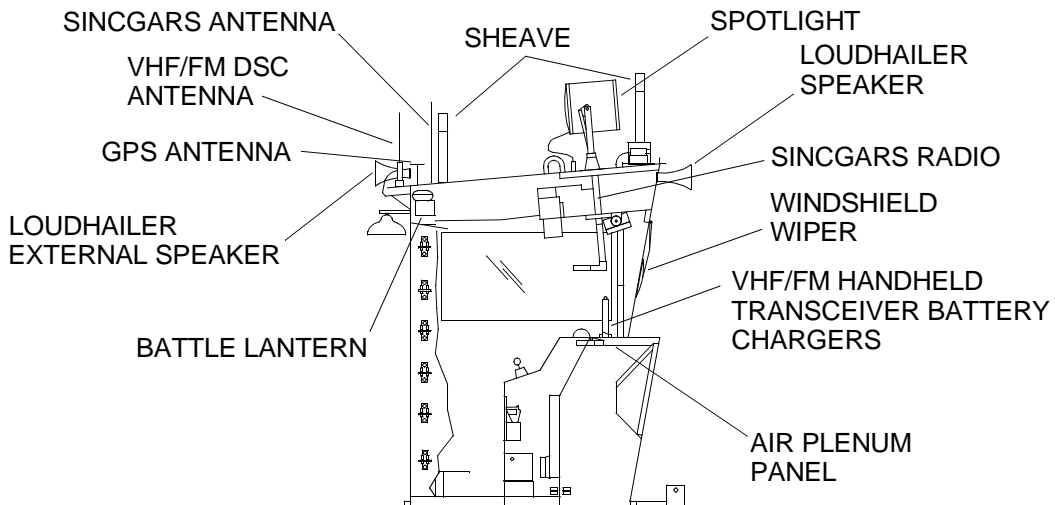


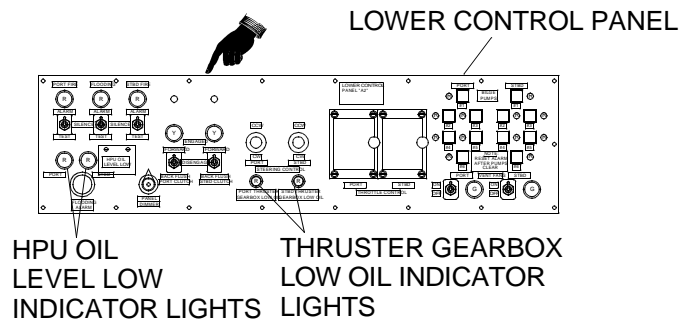
Table 1. Preventive Maintenance Checks and Services for the Causeway Ferry. (Continued)

ITEM NO.	INTERVAL	MAN-HOURS	ITEM TO BE CHECKED OR SERVICED	PROCEDURE	EQUIPMENT NOT READY/ AVAILABLE IF:
14	Before	0.4	Cab Lower Control Panel	<p>1. Check all control panels and associated switches, gages, steering levers, throttle and other controls and indicators for obvious damage. If damaged or non-functioning control panels and associated switches, gages, steering levers, throttle and other controls and indicators are found, contact unit maintenance.</p> <p>2. HPU OIL LEVEL LOW indicator light(s). Port and stbd, red indicator light(s) off. If on, check and fill appropriate hydraulic tank to proper level.</p>	Damage or non-functioning control panels and associated switches, gages, steering levers, throttle and other controls and indicators.

NOTE

At initial start-up thruster gearbox low oil indicator will go on momentarily and then go out.

			<p>3. THRUSTER GEARBOX LOW OIL indicator light(s). Port and stbd indicator light(s) off. If on, check and fill appropriate pump-jet gearbox to proper level.</p>
--	--	--	--



			<p>4. PORT and STBD FIRE ALARM/SILENCE/ TEST switches and indicators. Select TEST position momentarily. Horn sounds, red light comes on. Return switch to ALARM position. If red light does not come on or horn does not sound, contact unit maintenance.</p>	Fire alarms are inoperative.
--	--	--	---	------------------------------

Table 1. Preventive Maintenance Checks and Services for the Causeway Ferry. (Continued)

ITEM NO.	INTERVAL	MAN-HOURS	ITEM TO BE CHECKED OR SERVICED	PROCEDURE	EQUIPMENT NOT READY/ AVAILABLE IF:
14	Before	0.4	Cab Lower Control Panel (Cont'd)	<p>5. FLOODING ALARM/ SILENCE/TEST switch and indicator. Select TEST position momentarily. Horn sounds, red light comes on. Return switch to ALARM position. If red light does not come on or horn does not sound, contact unit maintenance.</p> <p>6. PANEL DIMMER switch. Functionally test switch. If switch is inoperative, contact unit maintenance.</p>	Flooding alarm is inoperative.
<p>The diagram shows a detailed view of the control panel. A hand is shown pointing to a specific switch. Labels with leader lines identify various components: 'FIRE ALARM SWITCHES AND INDICATORS' (top left), 'FLOOD INDICATOR LIGHTS (TYP)' (top right), 'FLOOD ALARM SWITCHES AND INDICATORS' (bottom left), 'PANEL DIMMER SWITCH' (bottom center), and 'LOWER CONTROL PANEL' (bottom right).</p>					
				<p>7. THROTTLE CONTROL levers. Check port and stbd control levers for ease of movement. Throttles must move easily back and forth. Return throttles to the idle position. If levers are binding or inoperative, contact unit maintenance.</p> <p>8. STEERING CONTROL joystick levers. Check port and stbd levers for ease of movement. Levers must move easily back and forth. If levers are binding or inoperative, contact unit maintenance.</p>	<p>Lever binding or inoperative.</p> <p>Lever binding or inoperative.</p>

Table 1. Preventive Maintenance Checks and Services for the Causeway Ferry. (Continued)

ITEM NO.	INTERVAL	MAN-HOURS	ITEM TO BE CHECKED OR SERVICED	PROCEDURE	EQUIPMENT NOT READY/ AVAILABLE IF:
14	Before	0.4	Cab Lower Control Panel (Cont'd)	<p>9. Functionally check PORT/STBD CLUTCH toggle switches and indicators.</p> <p>a. Place toggle switches in the FORWARD and then BACK FLUSH positions. Engaged indicator yellow lights will come on in both positions. If toggle switches or lights are inoperative, contact unit maintenance.</p> <p>b. Place toggle switches in the DISENGAGED position. Yellow indicator lights are off. If toggle switches or lights are inoperative, contact unit maintenance.</p>	Switch and/or indicator inoperative.

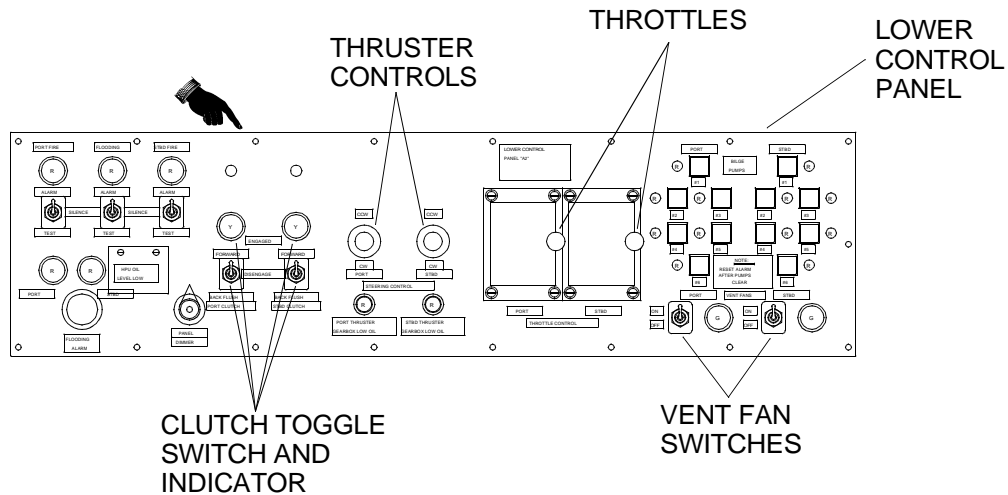
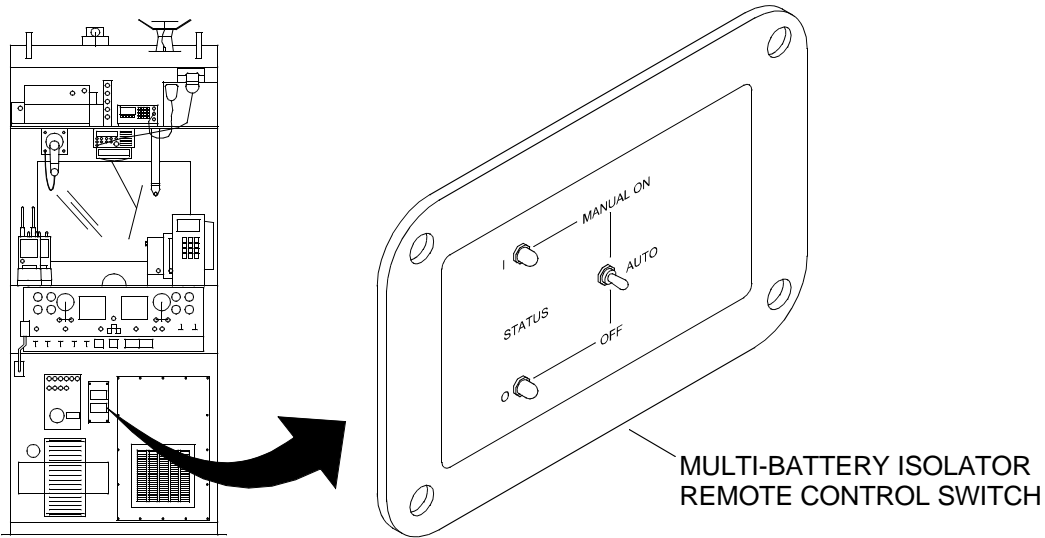
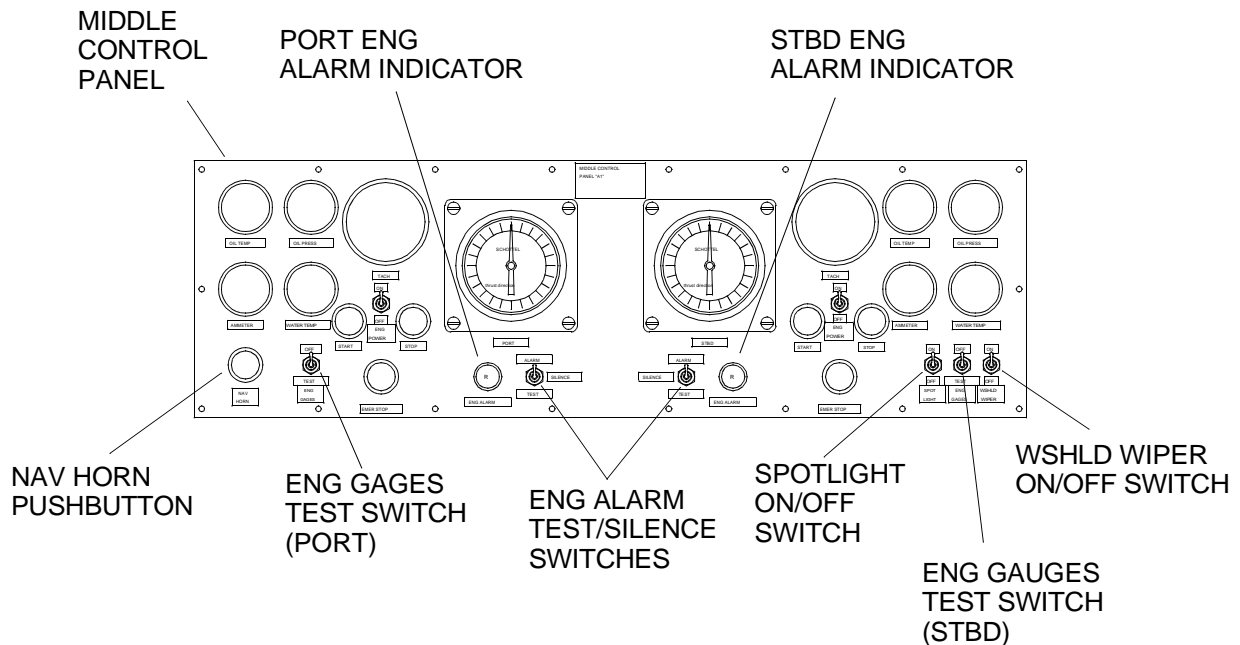


Table 1. Preventive Maintenance Checks and Services for the Causeway Ferry. (Continued)

ITEM NO.	INTERVAL	MAN-HOURS	ITEM TO BE CHECKED OR SERVICED	PROCEDURE	EQUIPMENT NOT READY/ AVAILABLE IF:
13	Before	0.1	Cab Circuit Breaker Panel	Verify switch is in the AUTO position and green light illuminates. If light does not illuminate, contact unit maintenance.	



37	Before	0.2	Middle Control Panel	1. Momentarily press NAV HORN push button. If NAV HORN is inoperative, contact unit maintenance.	Navigation horn is not functioning.
----	--------	-----	----------------------	--	-------------------------------------



■ **Table 1. Preventive Maintenance Checks and Services for the Causeway Ferry. (Continued)**

ITEM NO.	INTERVAL	MAN-HOURS	ITEM TO BE CHECKED OR SERVICED	PROCEDURE	EQUIPMENT NOT READY/ AVAILABLE IF:
37	Before	0.2	Middle Control Panel (Cont'd)	<p>2. ENG GAGES TEST switch(s). Momentarily hold port and stbd switches in the TEST position to activate engine status gages. If engine status gages are inoperative, contact unit maintenance.</p> <p>3. ENG ALARM/TEST/SILENCE switch(s) and indicator(s):</p> <p>a. Momentarily hold port and stbd toggle switches in the TEST position. Alarm bell will sound and red indicator(s) will come on. If toggle switches or lights are inoperative, contact unit maintenance.</p> <p>b. Return switch to the ALARM position when test is complete.</p>	<p>Alarm is not functioning.</p> <p>Alarm bell does not sound.</p>
14, 37	Before	0.1	Lower and Middle Control Panels	Start engines. (WP 0020 00)	
11	Before	0.1	Main Mast Winch	<p>1. Visually inspect main mast winch for signs of worn gears, worn parts dirt, paint, or any obstructions that would prevent the winch from operating properly. If evidence of corrosion, physical damage, broken welds, missing, loose, broken bolts and/or components is found, contact unit maintenance.</p> <p>2. Visually inspect main mast winch cable hook for signs of wear, damaged or missing pieces. If found, contact unit maintenance.</p> <p>3. Visually inspect main mast winch cable for signs of worn, frayed or missing pieces. If found, contact unit maintenance.</p> <p>4. Visually inspect main mast winch cable to verify cable extends 1" beyond cable keeper. If cable does not extend past keeper 1", contact unit maintenance.</p>	<p>Physical damage, broken welds, broken, missing, or loose bolts.</p> <p>Cable hook is worn, damaged or missing pieces.</p> <p>Cable is worn, frayed or missing pieces.</p> <p>Cable does not extend 1" past cable keeper.</p>

Table 1. Preventive Maintenance Checks and Services for the Causeway Ferry. (Continued)



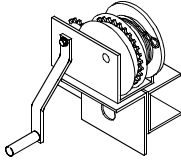
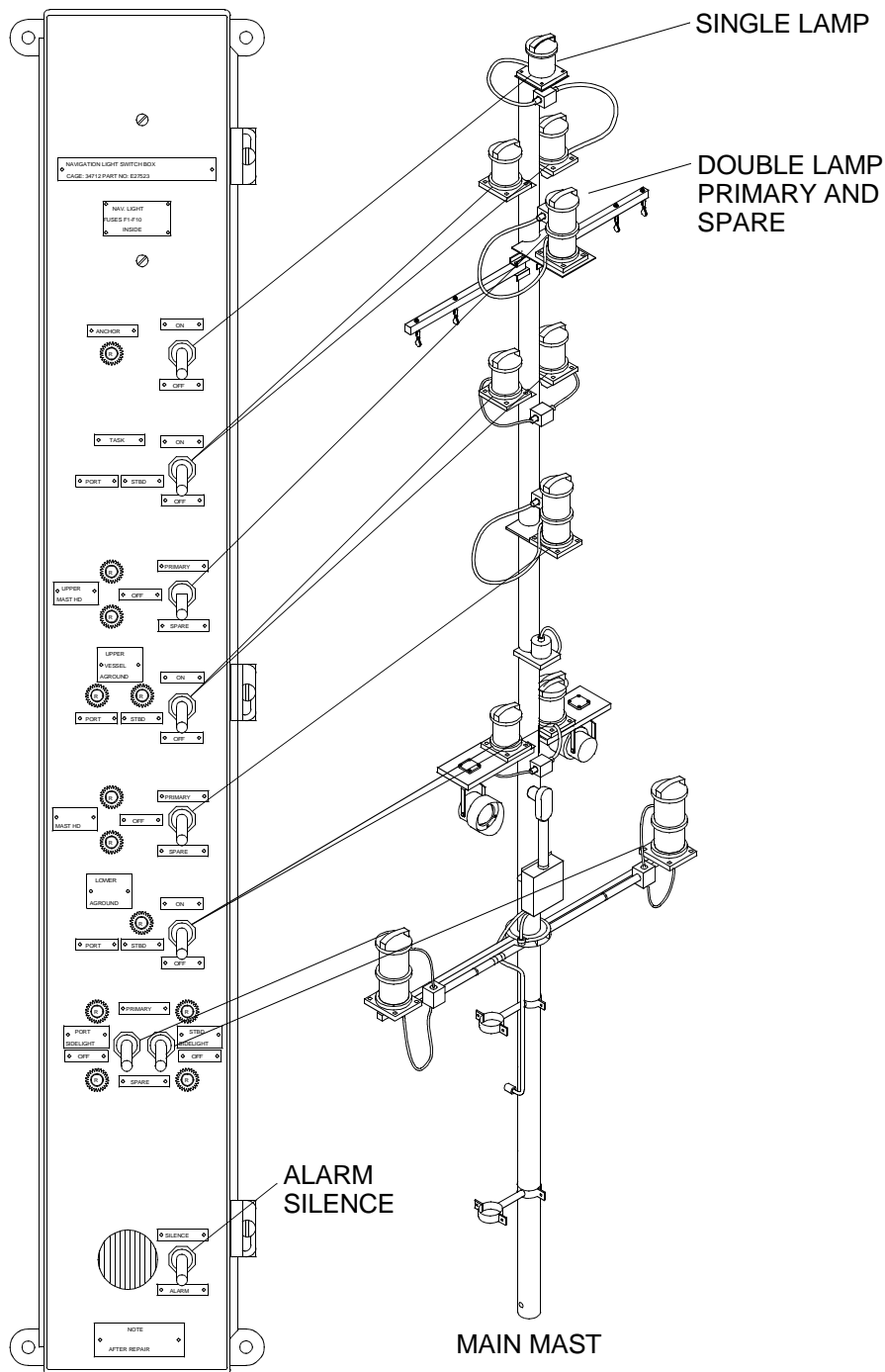
ITEM NO.	INTERVAL	MAN-HOURS	ITEM TO BE CHECKED OR SERVICED	PROCEDURE	EQUIPMENT NOT READY/ AVAILABLE IF:
<p>WARNING</p> <div style="display: flex; justify-content: space-around; align-items: center;"> <div style="text-align: center;">  <p>CHEMICAL</p> </div> <div style="text-align: center;">  <p>EYE PROTECTION</p> </div> </div>					
11	Before	0.1	Main Mast Winch (Cont'd)	<p>5. Inspect main mast winch brake friction disks for signs of oil or grease. If found, clean with rag and cleaner.</p> <p>6. Verify a thin film of automotive grease is on all ratchet teeth and on the outer diameter of the drum bearing. Apply a thin film of grease as necessary.</p> <p>7. Inspect main mast winch for signs of worn brake friction disks. If found, contact unit maintenance.</p>	<p>Brake friction disks have grease or oil on surface.</p> <p>Drum bearing and ratchet teeth require grease.</p> <p>Brake friction disks are worn to less than 1/6th of an inch.</p>
					
38	Before	0.1	Navigation Masts and Lights	<p>1. Visually inspect navigation mast and junction boxes for evidence of corrosion, physical damage, broken welds, missing or broken bolts and/or components. If evidence of corrosion, physical damage, broken welds, missing or broken bolts and/or components is found, contact unit maintenance.</p> <p>2. Visually inspect cable assemblies for loose connections and evidence of physical damage or wear. If loose connections or evidence of physical damage or wear is found, contact unit maintenance.</p>	

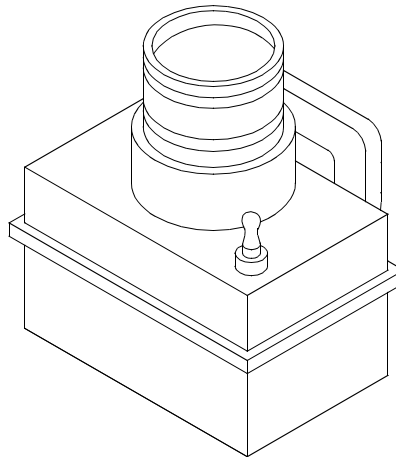
Table 1. Preventive Maintenance Checks and Services for the Causeway Ferry. (Continued)

ITEM NO.	INTERVAL	MAN-HOURS	ITEM TO BE CHECKED OR SERVICED	PROCEDURE	EQUIPMENT NOT READY/ AVAILABLE IF:
38	Before	0.1	Navigation Masts and Lights (Cont'd)	3. Visually inspect all navigational lights for cleanliness and evidence of physical damage. If damage is found, contact unit maintenance.	



■ Table 1. Preventive Maintenance Checks and Services for the Causeway Ferry. (Continued)

ITEM NO.	INTERVAL	MAN-HOURS	ITEM TO BE CHECKED OR SERVICED	PROCEDURE	EQUIPMENT NOT READY/ AVAILABLE IF:
38/12	Before	0.1	Navigation Masts and Lights (Cont'd)	4. Ensure that all lights are in working condition by operating the switches on the stub/stern mast lights to the ON and OFF positions. If lights or switches are inoperative, contact unit maintenance.	Lights do not function.



NOTE

The audible click in the following step will not be heard while cranking the cable out.

11	During	0.1	Main Mast Winch	Verify proper winch operation by listening for an audible click as the winch cable is cranked in. If audible click is not heard, contact unit maintenance.	Audible click is not heard.
----	--------	-----	-----------------	--	-----------------------------

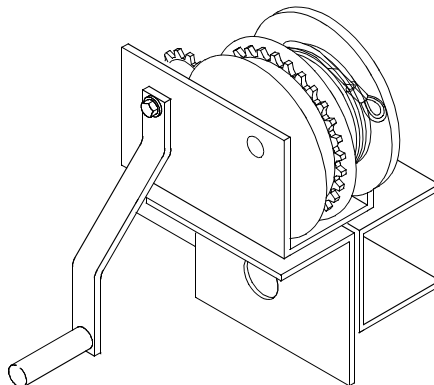
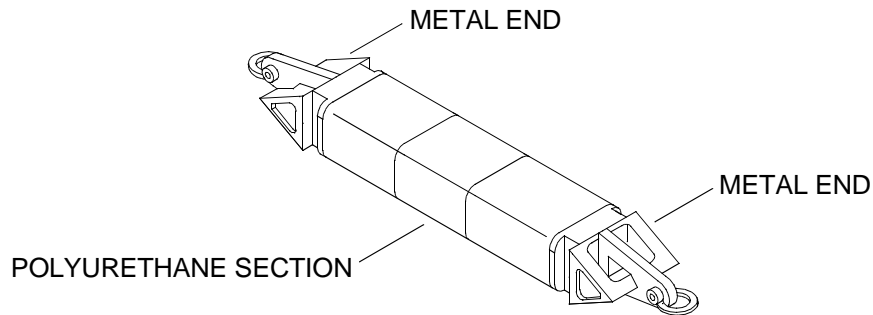


Table 1. Preventive Maintenance Checks and Services for the Causeway Ferry. (Continued)

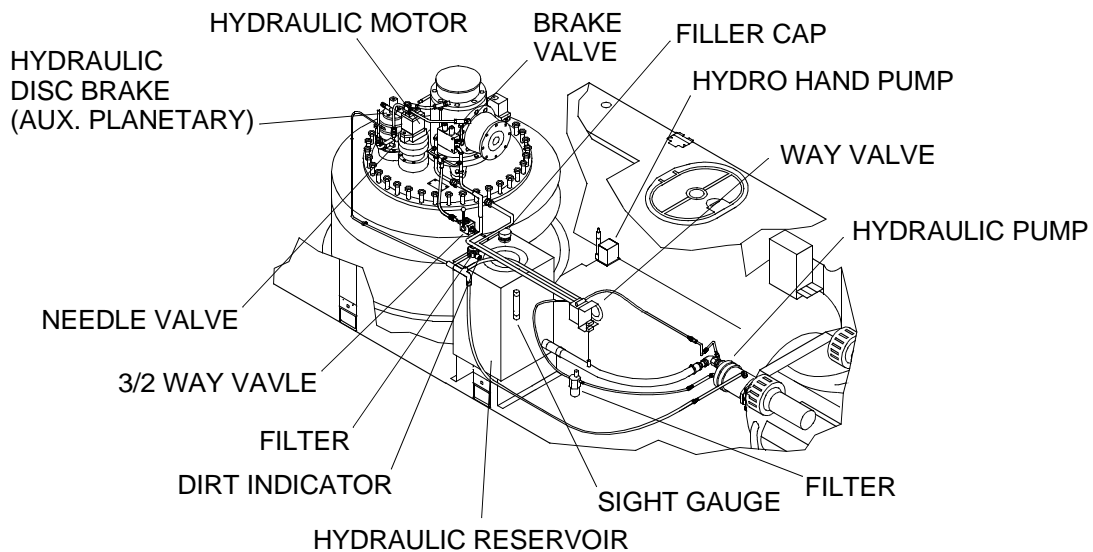
ITEM NO.	INTERVAL	MAN-HOURS	ITEM TO BE CHECKED OR SERVICED	PROCEDURE	EQUIPMENT NOT READY/ AVAILABLE IF:
2	During	0.1	Powered and Non-Powered Modules	1. Ensure all soft patches are secured for sea operation, including exhaust port patches (opposite exhaust port flapper valves). If soft patches are not secured, contact unit maintenance.	
				2. Inspect lazaret, machinery and fuel compartments for indications of water, oil or fuel leaks. Access via personnel hatches.	Class I fuel leaks or Class III water or oil leaks are found.

Table 1. Preventive Maintenance Checks and Services for the Causeway Ferry. (Continued)

ITEM NO.	INTERVAL	MAN-HOURS	ITEM TO BE CHECKED OR SERVICED	PROCEDURE	EQUIPMENT NOT READY/ AVAILABLE IF:
4	During	0.5	Flexors	1. Inspect visible portions of installed flexors for separation of the polyurethane material in the center. If found, contact unit maintenance. 2. Inspect visible portions of installed flexors for cracks in the external weldments on the ends. If found, contact unit maintenance.	Separation of the polyurethane material in the center of the flexor is found. Cracks are discovered in the external weldments on the ends of the flexor.

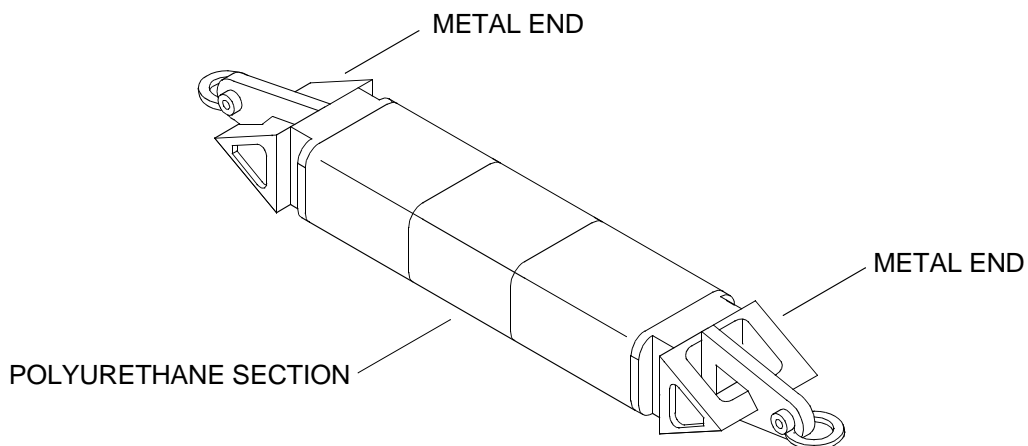


29	During	0.1	Hydraulic Reservoir	Check return filter dirt indicator. Dirt level must be at acceptable level as displayed on indicator. If dirt level is out of acceptable range (in red colored area) as indicated on dirt alarm, contact unit maintenance.	Dirt level is out of acceptable range (in red colored area) as indicated on dirt alarm.
----	--------	-----	---------------------	--	---



■ Table 1. Preventive Maintenance Checks and Services for the Causeway Ferry. (Continued)

ITEM NO.	INTERVAL	MAN-HOURS	ITEM TO BE CHECKED OR SERVICED	PROCEDURE	EQUIPMENT NOT READY/ AVAILABLE IF:
31	During	0.05	Pump-Jet	Inspect pump-jet assembly for unusual noise or vibration. If unusual noise or vibration is discovered, contact unit maintenance.	Unusual noise or vibration is discovered.
14, 37	After	0.3	Middle and Lower Control Panels	Perform engine shut-down. (WP 0020 00)	
39	After	0.1	Powered Section	Inspect lazaret, machinery, and fuel compartments for indications of water, oil or fuel leaks. Access via personnel hatches. Inspect all powered and non-powered modules for major deformation. If major deformation or leaks are found, contact unit maintenance.	Class I fuel leaks or Class III water or oil leaks are found. Major deformation is found.
4	After	0.5	Flexors	<p>1. Inspect uninstalled flexors for separation of the polyurethane material in the center. If found, contact unit maintenance.</p> <p>2. Inspect uninstalled flexors for cracks in the external weldments on the ends. If cracks in the external weldments on the ends of the flexor are found, contact unit maintenance.</p>	<p>Separation of the polyurethane material in the center of the flexor is found.</p> <p>Cracks are discovered in the external weldments on the ends of the flexor.</p>



■ Table 1. Preventive Maintenance Checks and Services for the Causeway Ferry. (Continued)

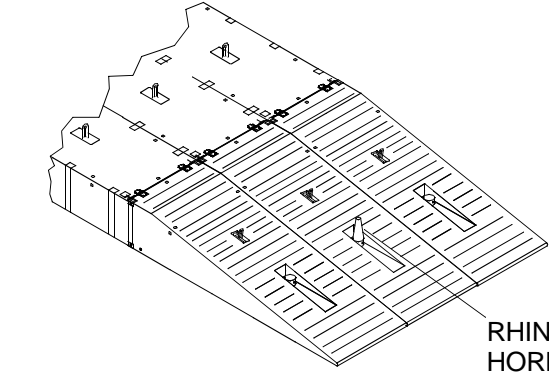
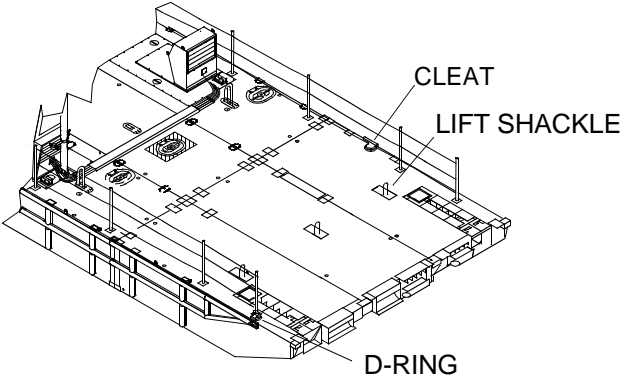
ITEM NO.	INTERVAL	MAN-HOURS	ITEM TO BE CHECKED OR SERVICED	PROCEDURE	EQUIPMENT NOT READY/ AVAILABLE IF:
5	After	0.1	Rhino Horn	Inspect for damage or cracks, missing parts, corrosion or broken welds. If damage, cracks, corrosion or broken parts are found or if hardware is missing, contact unit maintenance.	
					
6	After	0.1	Lift Shackles	Remove water from lift shackles. Lubricate lift shackles with grease and hand lubricating gun.	
					

Table 1. Preventive Maintenance Checks and Services for the Causeway Ferry. (Continued)

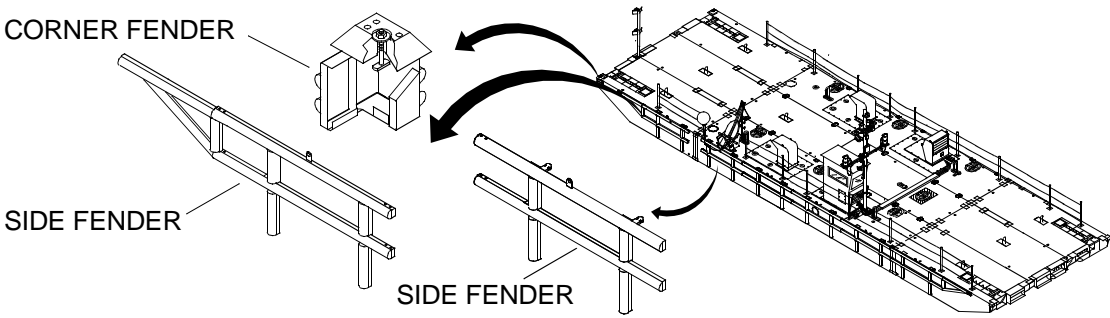
ITEM NO.	INTERVAL	MAN-HOURS	ITEM TO BE CHECKED OR SERVICED	PROCEDURE	EQUIPMENT NOT READY/ AVAILABLE IF:
7	After	0.1	Fenders	Inspect fenders for damage missing parts or wear. If damage or wear is found that would affect operation of the fender, contact unit maintenance.	
					
<p>NOTE</p>					
<p>Do not pump bilges overboard. Pump bilges into holding tank. If holding tank is full, take vessel to sludge point.</p>					
33	After	0.1	Bilge Pump System Compartment	<p>1. Inspect compartment for evidence of leaks of water, oil and/or fuel. If leakage is found, contact unit maintenance.</p> <p>2. If only water is present, activate bilge pump(s), as indicated by the red flood location light(s) on the operators control console in the operators cab, by pushing adjacent bilge pump push buttons. Once water is removed, the bilge pump(s) will automatically stop.</p>	Evidence of Class III leakage of water or oil or Class I leakage of fuel is found.

Table 1. Preventive Maintenance Checks and Services for the Causeway Ferry. (Continued)

ITEM NO.	INTERVAL	MAN-HOURS	ITEM TO BE CHECKED OR SERVICED	PROCEDURE	EQUIPMENT NOT READY/ AVAILABLE IF:
17	After	0.1	Electrical Junction and Terminal Boxes	<p>1. Visually inspect electrical wiring is securely connected, clean and undamaged. If wiring is not securely connected, dirty or damaged, contact unit maintenance.</p> <p>2. Visually inspect all accessible fuse terminal blocks and connections for to verify they are securely connected and supported, that insulation is not cracked or chafed and that conduit and shielding are secure and in good condition. If fuse and terminal blocks are not securely connected or they are cracked, chafed or damaged, contact unit maintenance.</p>	

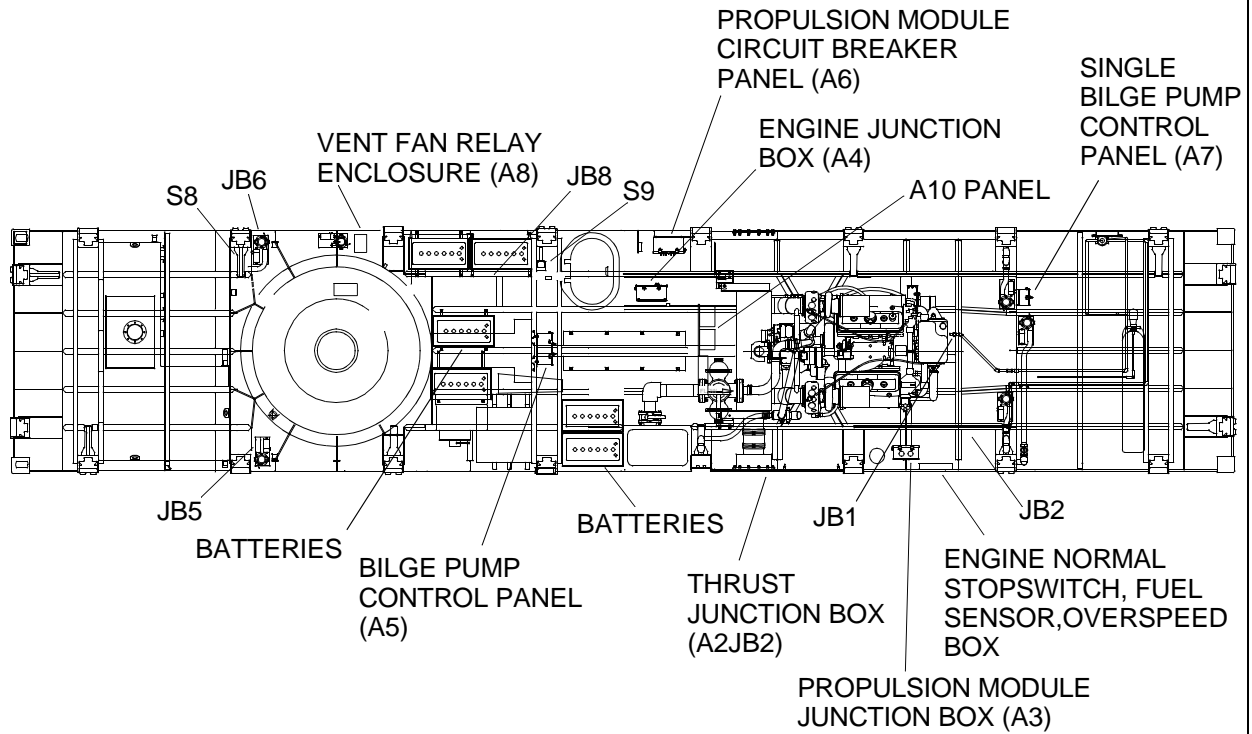


Table 1. Preventive Maintenance Checks and Services for the Causeway Ferry. (Continued)

ITEM NO.	INTERVAL	MAN-HOURS	ITEM TO BE CHECKED OR SERVICED	PROCEDURE	EQUIPMENT NOT READY/ AVAILABLE IF:
<p>WARNING</p> <p>Coolant is hot and under pressure. Contact with hot coolant could cause injury to personnel.</p>					
18	After	0.1	Raw Water Cooling System	<ol style="list-style-type: none"> 1. Inspect the cooling system for leaks or excessive puddling around its base. If leaks or puddling are found, contact unit maintenance. 2. Close the sea chest butterfly valves, both port and starboard. If valves are inoperative, contact unit maintenance. 	Class III leakage is found.
				<ol style="list-style-type: none"> 3. Freezing weather (below 32°F) only, drain all raw water from the raw water cooling system as follows: <ol style="list-style-type: none"> a. Open all raw water system petcock drains to drain the system. Leave petcocks open until the next start-up. If valves are inoperative, contact unit maintenance. b. Drain the transfer case oil cooler by disconnecting the raw water outlet hose at the lowest point. Connect hose when system has drained. 	

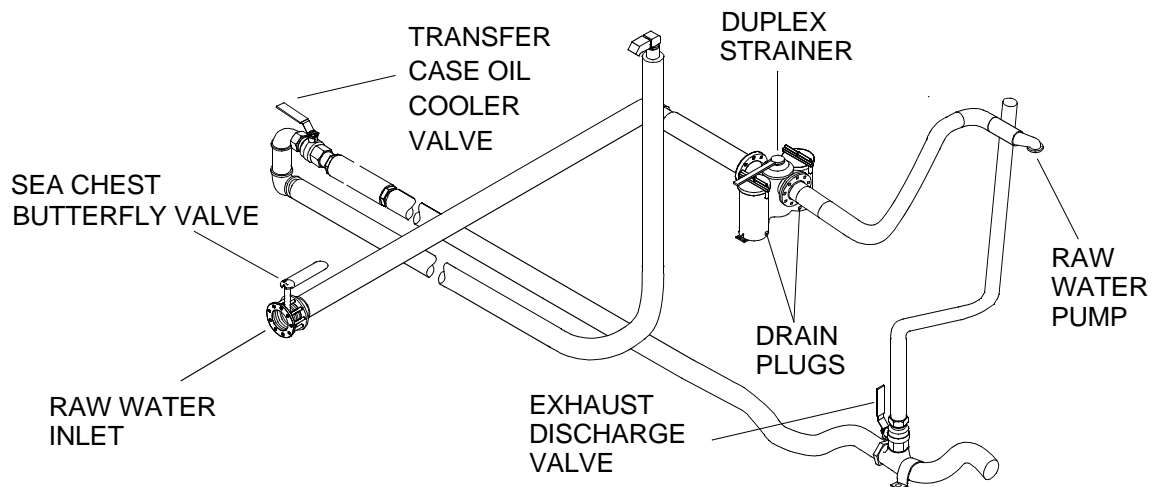


Table 1. Preventive Maintenance Checks and Services for the Causeway Ferry. (Continued)

ITEM NO.	INTERVAL	MAN-HOURS	ITEM TO BE CHECKED OR SERVICED	PROCEDURE	EQUIPMENT NOT READY/ AVAILABLE IF:
18	After	0.1	Raw Water Cooling System (Cont'd)	<p>c. Drain the raw water pump as follows: Loosen the six cap screws from the cover. Tap the cover to break the seal. Drain any water. Replace the cover and cap screws. Tighten the cap screws to secure the seal.</p> <p>d. Drain the muffler by removing drain plugs. Install plugs when muffler has drained.</p> <p>e. Drain the duplex strainer by removing the drain plugs at the bottom of each basket housing. Replace plugs when the strainer has drained.</p> <p>f. In the event of freeze up or other damage, contact unit maintenance.</p>	

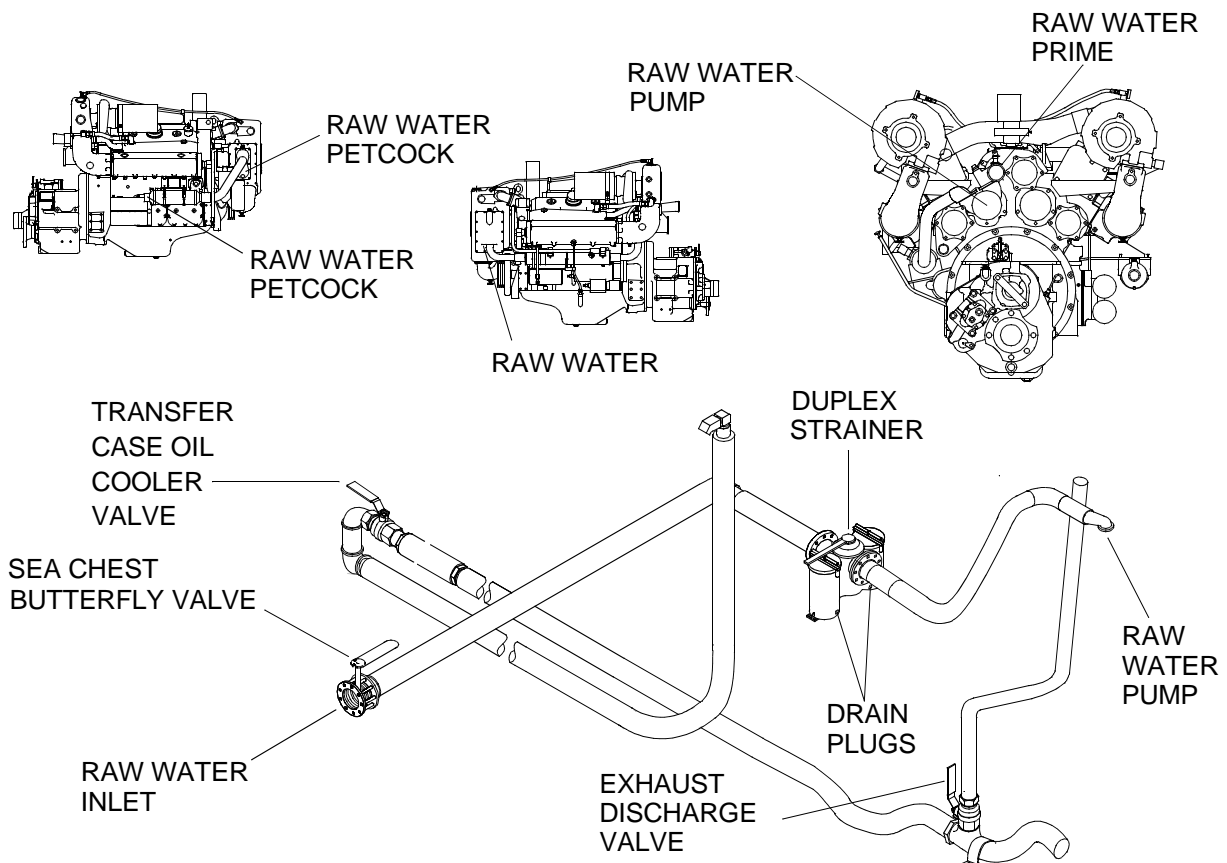







Table 1. Preventive Maintenance Checks and Services for the Causeway Ferry. (Continued)

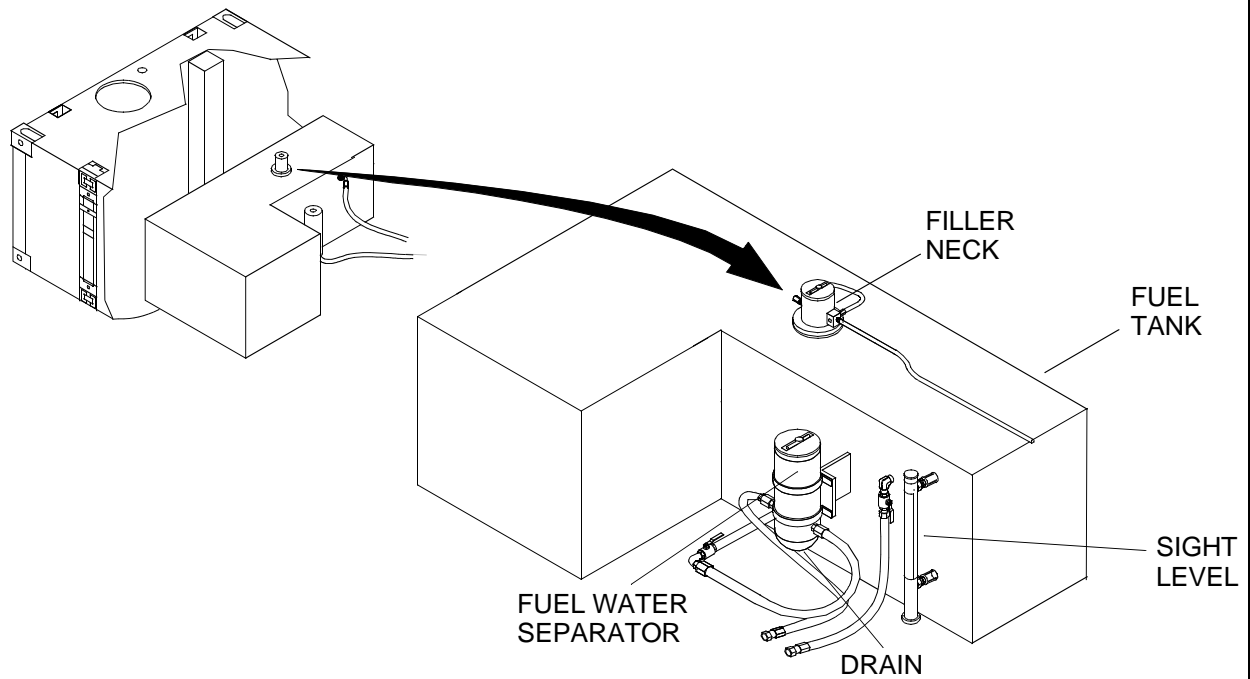
ITEM NO.	INTERVAL	MAN-HOURS	ITEM TO BE CHECKED OR SERVICED	PROCEDURE	EQUIPMENT NOT READY/ AVAILABLE IF:
19	After	0.1	Bilge Pumps	Check all bilge pumps and float switches for condition and proper operation. Look for evidence of water leaks, loose pump connections and/or damage. If pumps or float switches are inoperative or water leaks, loose connections or damage is found, contact unit maintenance.	
20	After	0.1	Diesel Engine	<ol style="list-style-type: none"> 1. Make a visual inspection for oil leaks around the filters and the external oil lines. If oil leaks are found, contact unit maintenance. 2. Visually inspect the oil dipstick. If metal particles are found in it, the oil must be completely changed, Contact unit maintenance. Record current engine hour reading in logbook and compare with oil change repair records. 	Class III oil leakage is found.

Table 1. Preventive Maintenance Checks and Services for the Causeway Ferry. (Continued)

ITEM NO.	INTERVAL	MAN-HOURS	ITEM TO BE CHECKED OR SERVICED	PROCEDURE	EQUIPMENT NOT READY/ AVAILABLE IF:
<p>WARNING</p> <div style="display: flex; justify-content: space-around; align-items: center;"> <div style="text-align: center;">  <p>CHEMICAL</p> </div> <div style="text-align: center;">  <p>EYE PROTECTION</p> </div> <div style="text-align: center;">  <p>EXPLOSION</p> </div> </div>					
24	After	0.2	Batteries	<p>1. Verify battery electrolyte levels completely cover the plates, without electrolyte overflowing the battery, and that connections are clean and tight, both port and starboard. Add reagent distilled water, if necessary. If connections are loose, batteries are unserviceable or will not start engines, contact unit maintenance.</p> <p>2. Inspect battery system for damage. If damage is found, contact unit maintenance.</p>	Batteries are unserviceable or will not start engines.
<p>WARNING</p> <div style="display: flex; justify-content: space-around; align-items: center;"> <div style="text-align: center;">  <p>FIRE</p> </div> <div style="text-align: center;">  <p>EXPLOSION</p> </div> </div> <p>Fuel and engine oil are highly flammable. Sparks or open flames should be kept away. Failure to comply may result in serious injury or death to personnel.</p> <p>Provide adequate ventilation of the vessel spaces. Failure to comply may result in serious injury or death to personnel.</p> <p>Use approved procedures when cleaning up fuel spills. Take proper precautions when removing or installing any fuel system component. Failure to comply may result in serious injury to death to personnel.</p>					
32	After	0.2	Fuel System	1. Check for leaks around fuel tank and fuel lines. If leaks are found, contact unit maintenance.	Class I fuel leakage is found.

■ Table 1. Preventive Maintenance Checks and Services for the Causeway Ferry. (Continued)

ITEM NO.	INTERVAL	MAN-HOURS	ITEM TO BE CHECKED OR SERVICED	PROCEDURE	EQUIPMENT NOT READY/ AVAILABLE IF:
32	After	0.2	Fuel System (Cont'd)	<p>2. Examine fuel lines and flexible hoses for leaks. Check that fittings, clamps and ties are secure. Hoses must not be resting or touching shafts, couplings, heated surfaces, sharp edges or other areas that might sever or rupture fuel system parts. If fuel leakage is found or hoses are resting or touching shafts, couplings, heated surfaces, sharp edges or other areas that might sever or rupture fuel system parts, contact unit maintenance.</p> <p>3. Refill fuel tank. DO NOT OVER FILL. Service with diesel fuel.</p>	Class I fuel leakage is found.



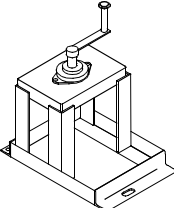
■ **Table 1. Preventive Maintenance Checks and Services for the Causeway Ferry. (Continued)**

ITEM NO.	INTERVAL	MAN-HOURS	ITEM TO BE CHECKED OR SERVICED	PROCEDURE	EQUIPMENT NOT READY/ AVAILABLE IF:
32	After	0.2	Fuel System (Cont'd)	<p>4. Visually inspect and drain water and/or other contaminants from fuel/water separator into an appropriate container. When pure fuel emerges, close drain cock. Check for leaks around tank. Ensure that fuel water separator was inspected and is operational. If fuel/water separator glass bowl is broken, tank has an excessive amount of water or fuel leaks are found, contact unit maintenance.</p> <p>5. Close fuel supply and return ball valves in both fuel compartments; port and starboard. If valves are inoperative, contact unit maintenance.</p>	Water in fuel prevents engine from starting or, broken fuel separator or glass or Class I fuel leakage is found.

Table 1. Preventive Maintenance Checks and Services for the Causeway Ferry. (Continued)

ITEM NO.	INTERVAL	MAN-HOURS	ITEM TO BE CHECKED OR SERVICED	PROCEDURE	EQUIPMENT NOT READY/ AVAILABLE IF:
<p>The diagram illustrates the fuel system layout. It shows a fuel tank connected to a fuel pump assembly. Two lines, labeled 'FUEL SUPPLY' and 'FUEL RETURN', run from the pump to the fuel tank. Each line is equipped with a 'BALL VALVE (SUPPLY)' and a 'BALL VALVE (RETURN)'. The entire system is housed within a structure labeled 'HULL'. An inset at the bottom left provides a detailed view of the fuel pump assembly, with an arrow pointing from the main diagram to this inset.</p>					

■ **Table 1. Preventive Maintenance Checks and Services for the Causeway Ferry. (Continued)**

ITEM NO.	INTERVAL	MAN-HOURS	ITEM TO BE CHECKED OR SERVICED	PROCEDURE	EQUIPMENT NOT READY/ AVAILABLE IF:
33	After	0.2	Bilge Pump System (Lazaret)	1. Check compartment for evidence of water and leaks. If leaks are found, contact unit maintenance.	Class III water leaks are found.
<p>NOTE</p> <p>Do not pump bilges overboard. Pump bilges into holding tank. If holding tank is full, take vessel to sludge point.</p>					
34	After	0.1	Emergency Steering Control Stand (stowed in lazaret)	<p>2. If water is present, activate bilge pump, as indicated by red flood location light on the operators cab control console in the operators cab, by pushing the adjacent bilge pump push button. Once water is removed, the bilge pump will automatically stop. If bilge pumps are inoperative, contact unit maintenance.</p> <p>Visually inspect control stand for obvious damage, evidence of corrosion, wear and loose or missing parts. If control stand is damaged, corroded, worn or has loose or missing parts, contact unit maintenance.</p>	Control stand is inoperative.
					
36	After	0.3	Operators Cab	<p>1. Check operator cab structure for damage to mountings. If damage is found, contact unit maintenance.</p> <p>2. Visually inspect cab mounted antennas, spotlight, bell, horn, steps, main mast sheaves, folding steps and mast for damage that would prevent operation. If damage is found that would prevent operation, contact unit maintenance.</p>	

■ **Table 1. Preventive Maintenance Checks and Services for the Causeway Ferry. (Continued)**

ITEM NO.	INTERVAL	MAN-HOURS	ITEM TO BE CHECKED OR SERVICED	PROCEDURE	EQUIPMENT NOT READY/ AVAILABLE IF:
36	After	0.3	Operators Cab (Cont'd)	<p>3. Functionally check windshield wiper. If windshield wiper is inoperative, contact unit maintenance.</p> <p>4. Functionally check spotlight. If spotlight is inoperative, contact unit maintenance.</p> <p>5. Functionally test battle lantern. If battle lantern is inoperative, contact unit maintenance.</p> <p>6. Functionally check VHF/FM DSC transceiver. If VHF/FM DSC transceiver is inoperative, contact unit maintenance.</p> <p>7. Functionally check loudhailer. If loudhailer is inoperative, contact unit maintenance.</p> <p>8. Functionally check Precision Lightweight Global Positioning Receiver (PLGR). If PLGR is inoperative, contact unit maintenance.</p> <p>9. Functionally check VHF/FM handheld transceivers and battery chargers. If transceivers or battery chargers are inoperative, contact unit maintenance.</p> <p>10. Functionally check SINGARS radio. If SINGARS radio is inoperative, contact unit maintenance.</p> <p>11. Inspect all radio antennae, handsets, cables and batteries. If damage is found that would prevent operation, contact unit maintenance.</p>	<p>VHF/FM DSC transceiver is inoperative. VHF/FM DSC transceiver is a safety requirement and must be operational.</p>

Table 1. Preventive Maintenance Checks and Services for the Causeway Ferry. (Continued)

ITEM NO.	INTERVAL	MAN-HOURS	ITEM TO BE CHECKED OR SERVICED	PROCEDURE	EQUIPMENT NOT READY/ AVAILABLE IF:
<p>Labels for the top diagram (Side View):</p> <ul style="list-style-type: none"> SINGGARS ANTENNA VHF/FM DSC ANTENNA GPS ANTENNA LOUDHAILER EXTERNAL SPEAKER BATTLE LANTERN FOLDING STEPS SHEAVE SPOTLIGHT LOUDHAILER SPEAKER SINGGARS RADIO WINDSHIELD WIPER VHF/FM HANDHELD TRANSCEIVER BATTERY CHARGERS AIR PLENUM PANEL 					
<p>Labels for the bottom diagram (Front View):</p> <ul style="list-style-type: none"> NAVIGATION HORN SINGGARS RADIO VHF/FM HANDHELD TRANSCEIVERS MAPLIGHT REMOTE CONTROL SWITCH HEATER CONTROL VHF/FM DSC TRANSCEIVER LOUDHAILER INTERFACE AND SWITCHBOX 					

■ **Table 1. Preventive Maintenance Checks and Services for the Causeway Ferry. (Continued)**

ITEM NO.	INTERVAL	MAN-HOURS	ITEM TO BE CHECKED OR SERVICED	PROCEDURE	EQUIPMENT NOT READY/ AVAILABLE IF:
38/12	After	0.1	Navigation Masts and Lights	<p>1. Visually inspect navigation mast, stern mast and junction boxes for evidence of corrosion, physical damage, broken welds, missing or broken bolts and/or components. If evidence of corrosion, physical damage, broken welds, missing or broken bolts and/or components is found, contact unit maintenance.</p> <p>2. Visually inspect cable assemblies for loose connections and evidence of physical damage or wear. If loose connections or evidence of physical damage or wear is found, contact unit maintenance.</p> <p>3. Visually inspect all navigational lights for cleanliness and evidence of physical damage. If damage is found, contact unit maintenance.</p> <p>4. Ensure that all lights are in working condition by operating the switches on mast enclosure (NAV Light Switch Box) in the cab to the ON and OFF positions. If lights or switches are inoperative, contact unit maintenance.</p> <p>5. Ensure stern light switches are in working condition by operating the switches to the ON and OFF positions. If lights or switches are inoperative, contact unit maintenance.</p> <p>6. Ensure stub light switches are in working condition by operating the switches to the ON and OFF positions. If lights or switches are inoperative, contact unit maintenance.</p>	

Table 1. Preventive Maintenance Checks and Services for the Causeway Ferry. (Continued)

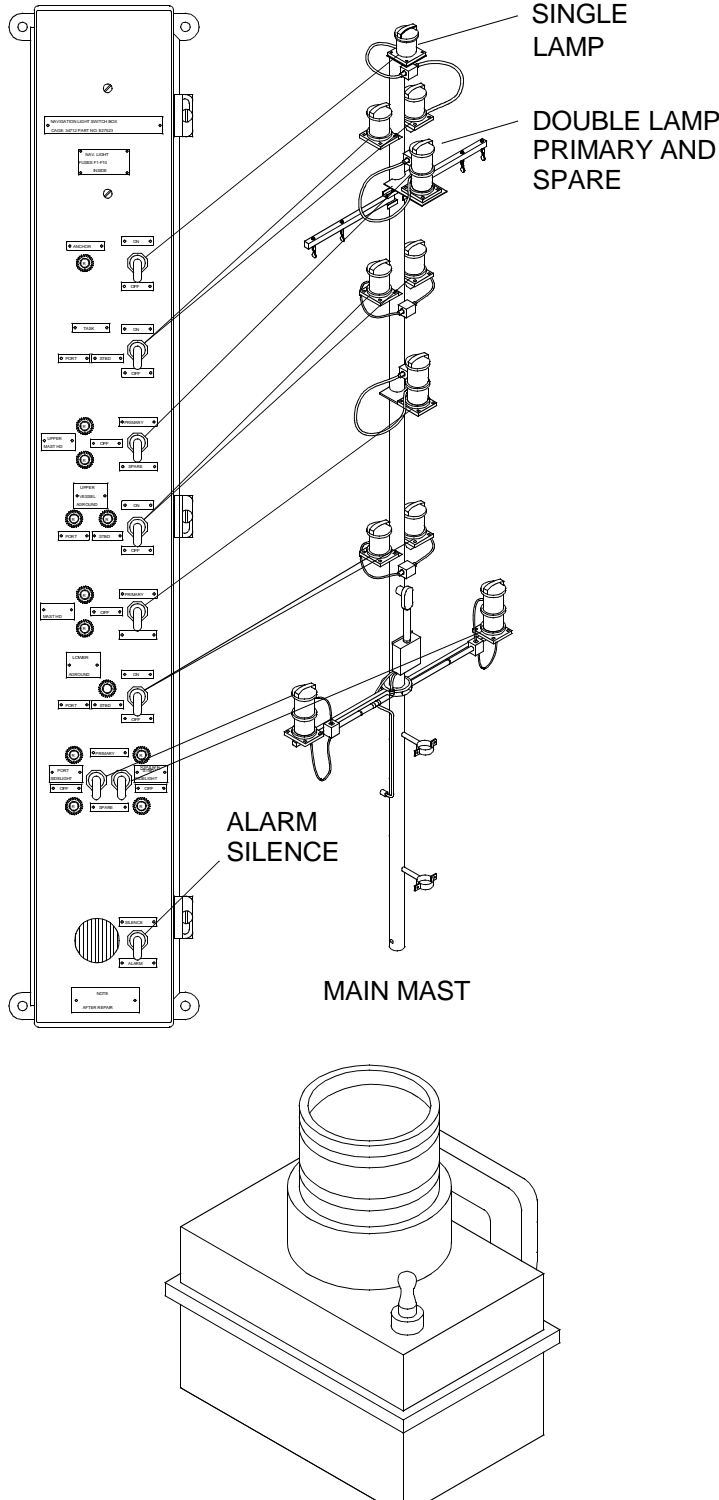
ITEM NO.	INTERVAL	MAN-HOURS	ITEM TO BE CHECKED OR SERVICED	PROCEDURE	EQUIPMENT NOT READY/ AVAILABLE IF:
					

Table 1. Preventive Maintenance Checks and Services for the Causeway Ferry. (Continued)



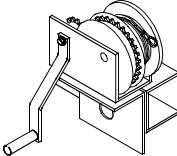
ITEM NO.	INTERVAL	MAN-HOURS	ITEM TO BE CHECKED OR SERVICED	PROCEDURE	EQUIPMENT NOT READY/ AVAILABLE IF:
<p>WARNING</p> <div style="display: flex; justify-content: space-around; align-items: center;"> <div style="text-align: center;">  <p>CHEMICAL</p> </div> <div style="text-align: center;">  <p>EYE PROTECTION</p> </div> </div>					
11	After	0.1	Main Mast Winch	<p>1. Visually inspect main mast winch for signs of worn gears, worn parts dirt, paint, or any obstructions that would prevent the winch from operating properly. If evidence of corrosion, physical damage, broken welds, worn gears, worn parts dirt, paint, missing, loose, broken bolts and/or components is found, contact unit maintenance.</p> <p>2. Visually inspect main mast winch cable for kinks, frayed cable or any damage. If main mast winch cable is kinked, frayed or damaged, contact unit maintenance</p>	<p>Corrosion, physical damage, broken welds, missing, loose, broken bolts and/or components.</p> <p>Cable is damaged, kinked or frayed.</p>
					
39	After	0.2	Powered Section	Using cleaner, clean engine and engine compartment with hot soapy water. Use clean cloths and mops to thoroughly dry.	
40	After	0.2	Slings	Check lifting slings for cuts, loose stitching and fraying.	Slings are cut, have loose stitching or frayed.
39	Weekly	1.0	Powered Section	Inspect modules for broken welds, cracks, punctures and corrosion. If found, contact unit maintenance.	Broken welds, cracks or punctures are present.

Table 1. Preventive Maintenance Checks and Services for the Causeway Ferry. (Continued)






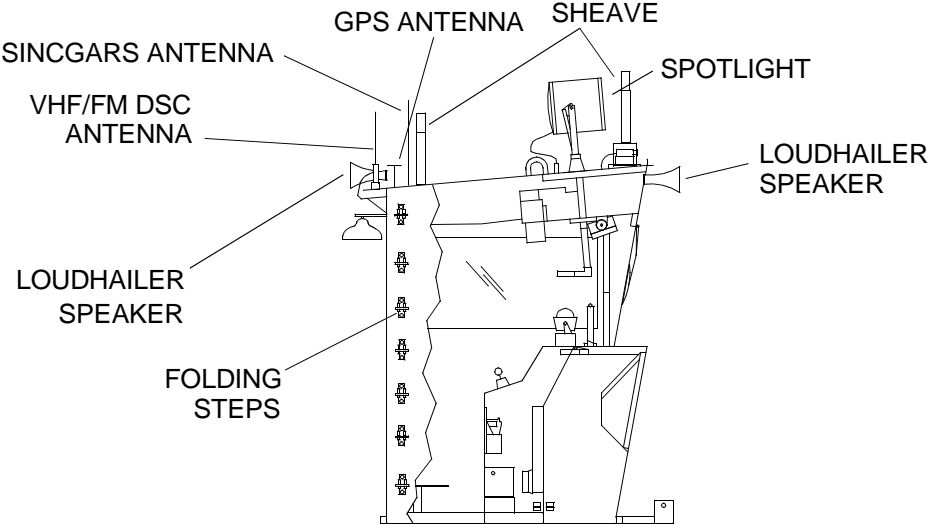
ITEM NO.	INTERVAL	MAN-HOURS	ITEM TO BE CHECKED OR SERVICED	PROCEDURE	EQUIPMENT NOT READY/ AVAILABLE IF:
<p>WARNING</p> <div style="display: flex; justify-content: space-around; align-items: center;"> <div style="text-align: center;">  <p>CHEMICAL</p> </div> <div style="text-align: center;">  <p>EYE PROTECTION</p> </div> <div style="text-align: center;">  <p>EXPLOSION</p> </div> </div>					
24	Weekly	0.3	Batteries	<ol style="list-style-type: none"> 1. Verify battery electrolyte levels completely cover the plates, without electrolyte overflowing the battery, and that connections are clean and tight, both port and starboard. Add reagent distilled water, if necessary. If connections are loose, batteries are unserviceable or will not start engines, contact unit maintenance. 2. Ensure all battery cable clamps and hold downs are tight. Make sure all are secure and free of corrosion. Tighten and clean if necessary and apply light layer of grease on cable clamps. 3. Inspect battery system for damage. If batteries are damaged or inoperative, contact unit maintenance. 4. If operating charging levels are found to be too low while starting engine, contact unit maintenance. DO NOT run battery down. 	<p>Batteries are unserviceable.</p> <p>Batteries will not start engines.</p>
20	Weekly	0.1	Diesel Engine	Start engine or place in long term storage. If engine does not start, contact unit maintenance.	Engine fails to start.

Table 1. Preventive Maintenance Checks and Services for the Causeway Ferry. (Continued)

ITEM NO.	INTERVAL	MAN-HOURS	ITEM TO BE CHECKED OR SERVICED	PROCEDURE	EQUIPMENT NOT READY/ AVAILABLE IF:
<p>WARNING</p> <div style="display: flex; justify-content: space-around; align-items: center;"> <div style="text-align: center;">  <p>CHEMICAL</p> </div> <div style="text-align: center;">  <p>EYE PROTECTION</p> </div> </div>					
25	Weekly	0.1	Marine Gear	Lubricate marine gear output seal weekly if water is present in the bilge. Use automotive and artillery grease and a hand lubricating gun.	
36	Weekly	0.3	Operators Cab	<ol style="list-style-type: none"> 1. Check operator cab structure for damage to mountings. If damage is found, contact unit maintenance. 2. Visually inspect cab mounted antennas, spotlight, bell, horn and mast for damage that would prevent operation. If damage is found that would prevent operation, contact unit maintenance. 	
					
36	Weekly	0.3	Operators Cab	<ol style="list-style-type: none"> 3. Functionally check windshield wiper. If windshield wiper is inoperative, contact unit maintenance. 4. Functionally check spotlight. If spotlight is inoperative, contact unit maintenance. 	

■ **Table 1. Preventive Maintenance Checks and Services for the Causeway Ferry. (Continued)**



ITEM NO.	INTERVAL	MAN-HOURS	ITEM TO BE CHECKED OR SERVICED	PROCEDURE	EQUIPMENT NOT READY/ AVAILABLE IF:
<p>WARNING</p> <div style="display: flex; justify-content: space-around; align-items: center;"> <div style="text-align: center;">  <p>CHEMICAL</p> </div> <div style="text-align: center;">  <p>EYE PROTECTION</p> </div> </div>					
36	Weekly	0.3	Operators Cab	<p>5. Lubricate shafts and pivot points. Use automotive and artillery grease and a hand lubricating gun.</p> <p>6. Functionally test battle lantern. If battle lantern is inoperative, contact unit maintenance.</p> <p>7. Functionally check VHF/FM DSC transceiver. If VHF/FM DSC transceiver is inoperative, contact unit maintenance.</p> <p>8. Functionally check loudhailer. If loudhailer is inoperative, contact unit maintenance.</p> <p>9. Functionally check Precision Lightweight Global Positioning Receiver (PLGR). If PLGR is inoperative, contact unit maintenance.</p> <p>10. Functionally check VHF/FM handheld transceivers and battery chargers. If transceivers or battery chargers are inoperative, contact unit maintenance.</p> <p>11. Functionally check SINCGARS radio. If SINCGARS radio is inoperative, contact unit maintenance.</p> <p>12. Inspect all radio antennae, handsets, cables, main mast sheaves, folding steps and batteries. If damage is found that would prevent operation, contact unit maintenance.</p>	VHF/FM DSC transceiver is inoperative.

Table 1. Preventive Maintenance Checks and Services for the Causeway Ferry. (Continued)

ITEM NO.	INTERVAL	MAN-HOURS	ITEM TO BE CHECKED OR SERVICED	PROCEDURE	EQUIPMENT NOT READY/ AVAILABLE IF:
<p>Labels for the top diagram (side view):</p> <ul style="list-style-type: none"> SINGGARS ANTENNA VHF/FM DSC ANTENNA GPS ANTENNA LOUDHAILER EXTERNAL SPEAKER BATTLE LANTERN SPOTLIGHT LOUDHAILER SPEAKER SINGGARS RADIO WINDSHIELD WIPER VHF/FM HANDHELD TRANSCEIVER BATTERY CHARGERS AIR PLENUM PANEL 					
<p>Labels for the bottom diagram (front view):</p> <ul style="list-style-type: none"> NAVIGATION HORN SINGGARS RADIO VHF/FM HANDHELD TRANSCEIVERS MAPLIGHT REMOTE CONTROL SWITCH HEATER CONTROL VHF/FM DSC TRANSCEIVER LOUDHAILER INTERFACE AND SWITCHBOX 					

Table 1. Preventive Maintenance Checks and Services for the Causeway Ferry. (Continued)

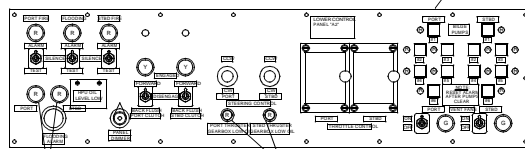
ITEM NO.	INTERVAL	MAN-HOURS	ITEM TO BE CHECKED OR SERVICED	PROCEDURE	EQUIPMENT NOT READY/ AVAILABLE IF:
14	Weekly	0.4	Cab Lower Control Panel	<p>1. Check all control panels and associated switches, gages, steering levers, throttle and other controls and indicators for obvious damage. If damaged or non-functioning control panels and associated switches, gages, steering levers, throttle and other controls and indicators are found, contact unit maintenance.</p> <p>2. HPU OIL LEVEL LOW indicator light(s). Port and stbd, red indicator light(s) off. If on, check and fill appropriate hydraulic tank to proper level.</p>	Damage or non-functioning control panels and associated switches gages, steering levers, throttle and other controls and indicators.

NOTE

At initial start-up thruster gearbox low oil indicator will go on momentarily and then go out.

			<p>3. THRUSTER GEARBOX LOW OIL indicator light(s). Port and stbd indicator light(s) off. If on, check and fill appropriate pump-jet gearbox to proper level.</p>	
--	--	--	--	--

LOWER CONTROL PANEL



HPU OIL LEVEL LOW INDICATOR LIGHTS

THRUSTER GEARBOX LOW OIL INDICATOR LIGHTS

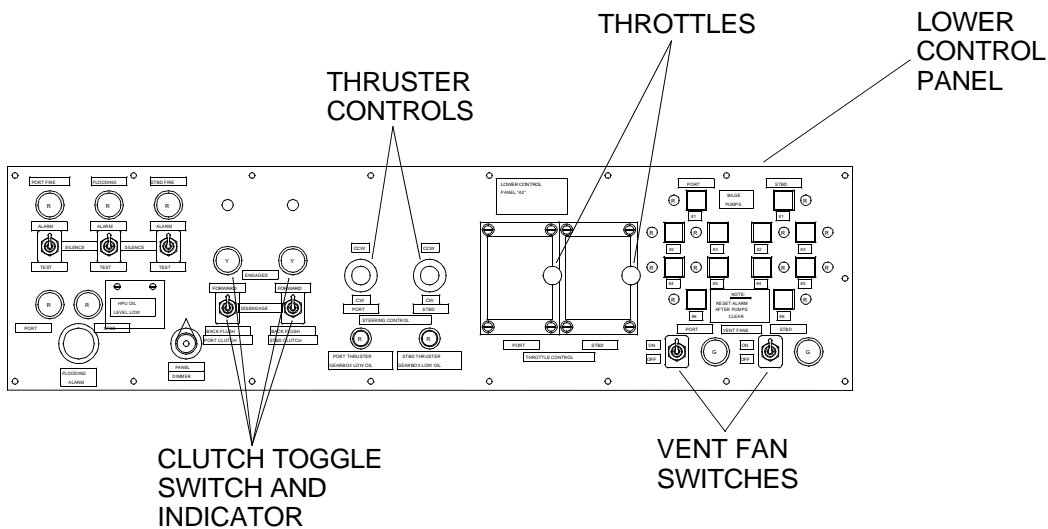
			<p>4. PORT and STBD FIRE ALARM/SILENCE/ TEST switches and indicators. Select TEST position momentarily. Horn sounds, red light comes on. Return switch to ALARM position. If red light does not come on or horn does not sound, contact unit maintenance.</p>	Fire alarms are inoperative.
--	--	--	---	------------------------------

Table 1. Preventive Maintenance Checks and Services for the Causeway Ferry. (Continued)

ITEM NO.	INTERVAL	MAN-HOURS	ITEM TO BE CHECKED OR SERVICED	PROCEDURE	EQUIPMENT NOT READY/ AVAILABLE IF:
14	Weekly	0.4	Cab Lower Control Panel (Cont'd)	<p>5. FLOODING ALARM/ SILENCE/TEST Switch and indicator. Select TEST position momentarily. Horn sounds, red light comes on. Return switch to ALARM position. If red light does not come on or horn does not sound, contact unit maintenance.</p> <p>6. PANEL DIMMER switch. Functionally test switch. If switch is inoperative, contact unit maintenance.</p>	Flooding alarm is inoperative.
				<p>7. THROTTLE CONTROL levers. Check port and stbd control levers for ease of movement. Throttles must move easily back and forth. Return throttles to the idle position. If levers binding or inoperative, contact unit maintenance.</p> <p>8. STEERING CONTROL joystick levers. Check port and stbd levers for ease of movement. Levers must move easily back and forth. If levers binding or inoperative, contact unit maintenance.</p> <p>9. Functionally check PORT/STBD CLUTCH toggle switches and indicators.</p>	<p>Lever binding or inoperative.</p> <p>Lever binding or inoperative.</p> <p>Switch and/or indicator inoperative.</p>

Table 1. Preventive Maintenance Checks and Services for the Causeway Ferry. (Continued)

ITEM NO.	INTERVAL	MAN-HOURS	ITEM TO BE CHECKED OR SERVICED	PROCEDURE	EQUIPMENT NOT READY/ AVAILABLE IF:
14	Weekly	0.4	Cab Lower Control Panel (Cont'd)	<p>a. Place toggle switches in the FORWARD and then BACK FLUSH positions. Engaged indicator yellow lights will come on in both positions. If toggle switches or lights are inoperative, contact unit maintenance.</p> <p>b. Place toggle switches in the DISENGAGED position. Yellow indicator lights are off. If toggle switches or lights are inoperative, contact unit maintenance.</p>	



■ **Table 1. Preventive Maintenance Checks and Services for the Causeway Ferry. (Continued)**

ITEM NO.	INTERVAL	MAN-HOURS	ITEM TO BE CHECKED OR SERVICED	PROCEDURE	EQUIPMENT NOT READY/ AVAILABLE IF:
38/12	Weekly	1.5	Navigation Masts and Lights	<p>1. Lower the main mast and check for damaged or cracked lenses, bad gaskets, structural damage or inoperative condition. If damage is found, contact unit maintenance.</p> <p>2. Visually inspect navigation mast and junction boxes for evidence of corrosion, physical damage, broken welds, missing or broken bolts and/or components. If evidence of corrosion, physical damage, broken welds, missing or broken bolts and/or components is found, contact unit maintenance.</p> <p>3. Visually inspect cable assemblies for loose connections and evidence of physical damage or wear. If loose connections or evidence of physical damage or wear is found, contact unit maintenance.</p> <p>4. Visually inspect all navigational lights for cleanliness and evidence of physical damage. If damage is found, contact unit maintenance.</p>	

Table 1. Preventive Maintenance Checks and Services for the Causeway Ferry. (Continued)

ITEM NO.	INTERVAL	MAN-HOURS	ITEM TO BE CHECKED OR SERVICED	PROCEDURE	EQUIPMENT NOT READY/ AVAILABLE IF:

■ Table 1. Preventive Maintenance Checks and Services for the Causeway Ferry. (Continued)

ITEM NO.	INTERVAL	MAN-HOURS	ITEM TO BE CHECKED OR SERVICED	PROCEDURE	EQUIPMENT NOT READY/ AVAILABLE IF:
38/12	Weekly	1.5	Navigation Masts and Lights (Cont'd)	<p>5. Lower stern mast and check for damaged or cracked lenses, bad gaskets, structural damage or inoperative condition. If damage is found, contact unit maintenance.</p> <p>6. Visually inspect stern mast for evidence of corrosion, physical damage, broken welds, missing/ broken bolts and/or components. If evidence of corrosion, physical damage, broken welds, missing or broken bolts and/or components is found, contact unit maintenance.</p> <p>7. Visually inspect all navigational lights for cleanliness and evidence of physical damage. If damage is found, contact unit maintenance.</p> <p>8. Ensure that all lights are in working condition by operating the switches (located on the lights) to the ON and OFF positions. If lights or switches are inoperative, contact unit maintenance.</p>	

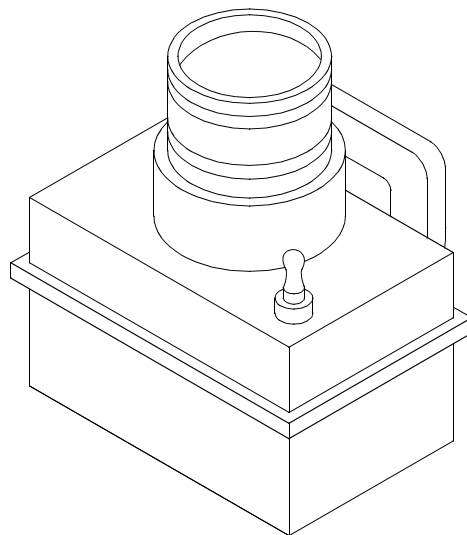
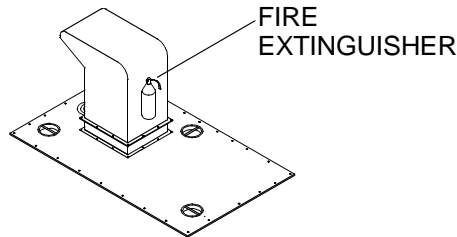


Table 1. Preventive Maintenance Checks and Services for the Causeway Ferry. (Continued)

ITEM NO.	INTERVAL	MAN-HOURS	ITEM TO BE CHECKED OR SERVICED	PROCEDURE	EQUIPMENT NOT READY/ AVAILABLE IF:
1	Monthly	0.5	Intake and Exhaust Plenums	<p>1. Inspect fire extinguisher for broken seal, damage to nozzle or red zone indication on gage. If seal is broken, nozzle is damaged, or a red zone indication is seen on gage, contact unit maintenance.</p> <p>2. Sign and date the fire extinguisher inspection tag and record the inspection in the deck logbook.</p>	Seal is broken, nozzle is damaged, or a red zone indication is seen on gage.



4	Monthly	1.0	Flexors	<p>1. Inspect uninstalled flexors for separation of the polyurethane material in the center. If found, contact unit maintenance.</p> <p>2. Inspect uninstalled flexors for cracks in the external welds on the ends. If found, contact unit maintenance.</p>	<p>Separation of the polyurethane material in the center of the flexor is found.</p> <p>Cracks are discovered in the external weldments on the ends of the flexor.</p>
---	---------	-----	---------	--	--

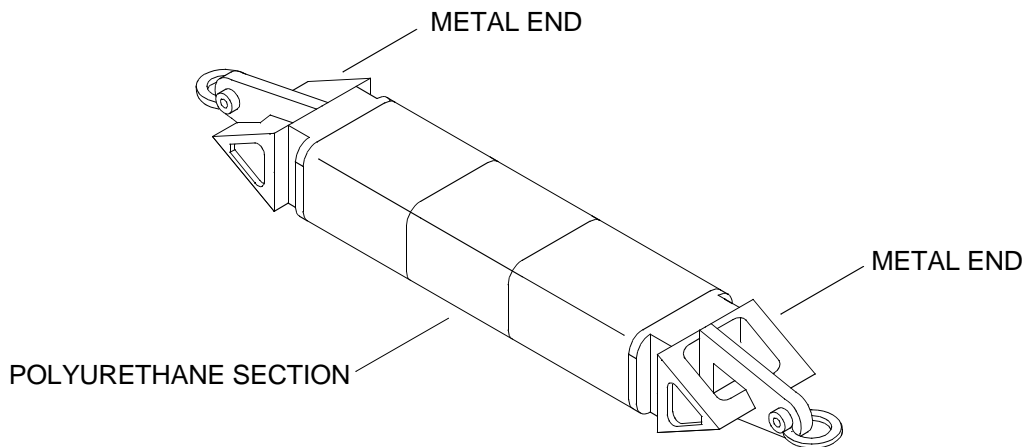
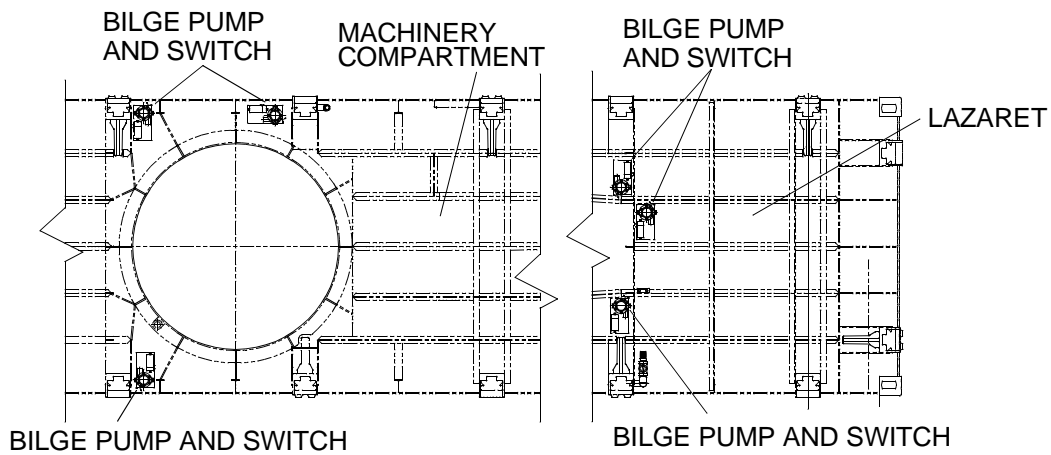


Table 1. Preventive Maintenance Checks and Services for the Causeway Ferry. (Continued)

ITEM NO.	INTERVAL	MAN-HOURS	ITEM TO BE CHECKED OR SERVICED	PROCEDURE	EQUIPMENT NOT READY/ AVAILABLE IF:
19	Monthly	0.2	Bilge Pumps	Check all bilge pumps and float switches for condition and proper operation. Look for evidence of water leaks, loose pump connections and/or damage. If damage or leakage is found, contact unit maintenance.	



WARNING

Use extreme care when inspecting or servicing CO2. Failure to comply could result in injury or death.

35	Monthly	0.1	Fire Suppression System	Inspect for discharge, leakage or expansion. Look for damaged or broken seals. If evidence of discharge, leakage, expansion or damaged or broken seals is found, contact unit maintenance.	Seals are damaged or broken, or evidence of excessive discharge is found.
----	---------	-----	-------------------------	--	---

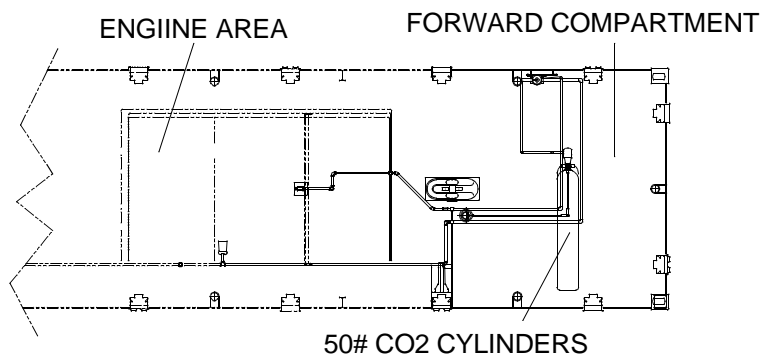


Table 1. Preventive Maintenance Checks and Services for the Causeway Ferry. (Continued)

ITEM NO.	INTERVAL	MAN-HOURS	ITEM TO BE CHECKED OR SERVICED	PROCEDURE	EQUIPMENT NOT READY/ AVAILABLE IF:
42	Monthly	5.0	Module Interlock Connector and Spring (Male Locking Pin)	1. Check male connector pin for deformation, twisting, bending and flatness. If any deformation of the pin is present, remove pin from service. Contact unit maintenance. 2. Check contact area where the pins seat against the guillotine bars for wear. If excessive wear is present, remove pin from service. Contact unit maintenance. 3. Check the pin to ensure stop bar is attached. If stop bar is removed, remove pin from service and replace stop bar. Contact unit maintenance. 4. Check the connector pin for cracks and/or unusual damage (missing material, notches, etc.) If any cracks and/or unusual damage is present, remove pin from service. Contact unit maintenance.	Any deformation of the pin is present. Excessive wear is present. If stop bar is removed. If any cracks and/or unusual damage is present.

WARNING

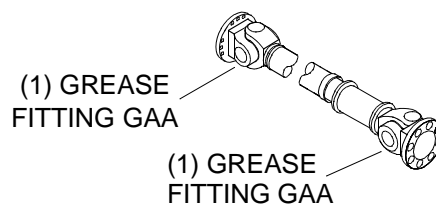
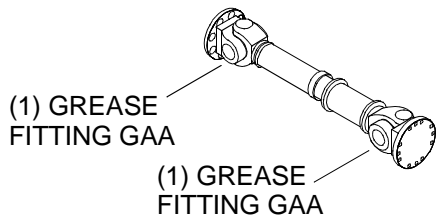


CHEMICAL




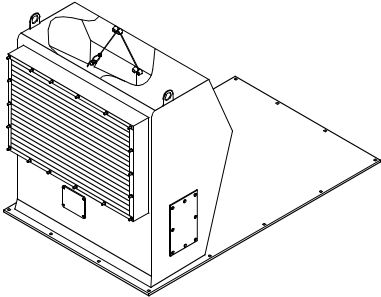

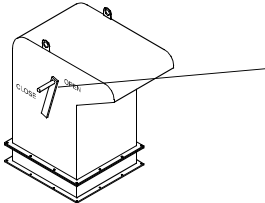
EYE PROTECTION

25	Monthly or 200 Hours	0.5	Drive Shafts (Cross and Bearing Grease Fittings)	Lubricate after first 200 hours of operation and monthly thereafter. Add lubricant until it appears at all journal cross bearings. Use automotive and artillery grease and a hand lubricating gun.
----	----------------------	-----	--	--



DRIVE SHAFTS (TYPICAL)

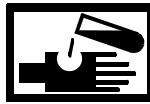
Table 1. Preventive Maintenance Checks and Services for the Causeway Ferry. (Continued)

ITEM NO.	INTERVAL	MAN-HOURS	ITEM TO BE CHECKED OR SERVICED	PROCEDURE	EQUIPMENT NOT READY/ AVAILABLE IF:
<p>WARNING</p>  <p>CHEMICAL</p>					
1	Quarterly	0.5	Intake Plenum (Hinges)	Lubricate with aircraft grease and a hand lubricating gun.	
 <p>INTAKE PLENUM HINGES</p>					
<p>WARNING</p>  <p>CHEMICAL</p>					
1	Quarterly	0.5	Exhaust Plenum (Pivots)	Lubricate with aircraft grease and a hand lubricating gun.	
 <p>GREASE NEAR SIDE FAR SIDE</p> <p>EXHAUST PLENUM PIVOTS</p>					
20	Quarterly 100 Hours	1.0	Diesel Engine	Perform AOAP sampling every 90 days or 100 hours, whichever comes first, as prescribed by DA PAM 738-750.	

■ **Table 1. Preventive Maintenance Checks and Services for the Causeway Ferry. (Continued)**

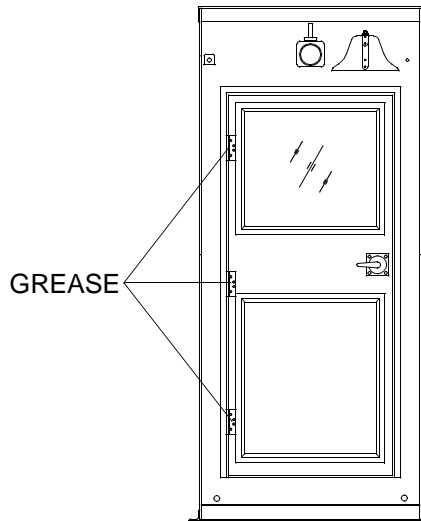
ITEM NO.	INTERVAL	MAN-HOURS	ITEM TO BE CHECKED OR SERVICED	PROCEDURE	EQUIPMENT NOT READY/ AVAILABLE IF:
25	Quarterly 100 Hours	1.0	Marine Gear	Perform AOAP sampling every 90 days or 100 hours, whichever comes first, as prescribed by and DA PAM 738-750.	
26	Quarterly 100 Hours	0.5	Transfer Case	Perform AOAP sampling every 90 days or 100 hours, whichever comes first, as prescribed by DA PAM 738-750.	

WARNING



CHEMICAL

36	Quarterly	0.5	Operators Cab (Door Hinges)	Lubricate with aircraft grease by hand.
----	-----------	-----	-----------------------------	---



OPERATORS CAB DOOR HINGES

Table 1. Preventive Maintenance Checks and Services for the Causeway Ferry. (Continued)



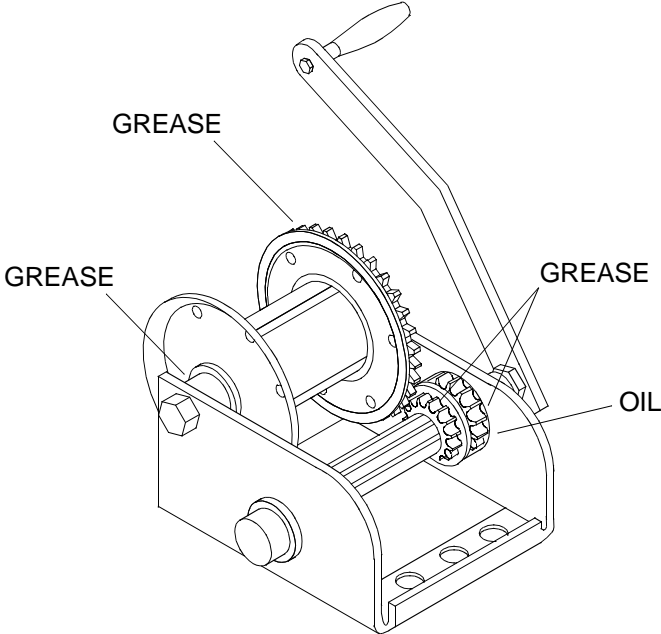
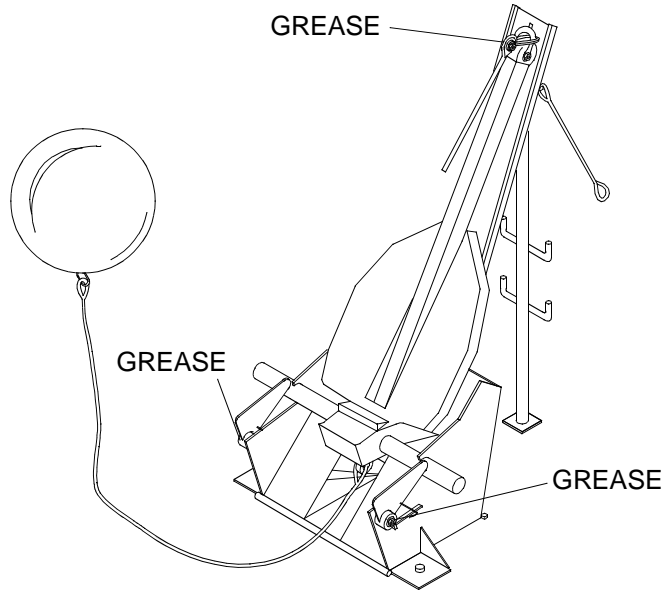
ITEM NO.	INTERVAL	MAN-HOURS	ITEM TO BE CHECKED OR SERVICED	PROCEDURE	EQUIPMENT NOT READY/ AVAILABLE IF:
<p>WARNING</p> <div style="display: flex; justify-content: space-around; align-items: center;"> <div style="text-align: center;">  <p>CHEMICAL</p> </div> <div style="text-align: center;">  <p>EYE PROTECTION</p> </div> </div>					
11	Quarterly	0.5	Main Mast Winch	<ol style="list-style-type: none"> 1. Lubricate drum spacer and gear teeth with a film of automotive grease. 2. Lubricate ratchet pawl pivot bushings and pinion threads with a film of automotive engine oil. 	Ratchet pawl, bushings and pinion threads not lubricated.
					

Table 1. Preventive Maintenance Checks and Services for the Causeway Ferry. (Continued)

ITEM NO.	INTERVAL	MAN-HOURS	ITEM TO BE CHECKED OR SERVICED	PROCEDURE	EQUIPMENT NOT READY/ AVAILABLE IF:
8	Quarterly	0.5	Anchorboard Assembly (Pivot Points)	Lubricate as required. Lubricate with aircraft grease and a hand lubricating gun.	



ANCHORBOARD PIVOT PIN POINTS

WARNING

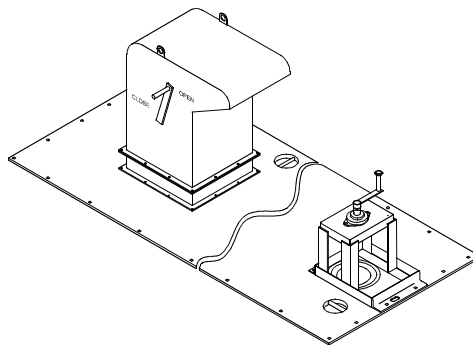


CHEMICAL



EYE PROTECTION

34	Quarterly	0.1	Emergency Steering Control Stand	Lubricate flange grease fittings with automotive and artillery grease and a hand lubricating gun.	
----	-----------	-----	----------------------------------	---	--



EMERGENCY STEERING SYSTEM - FLANGE GREASE FITTINGS

■ **Table 1. Preventive Maintenance Checks and Services for the Causeway Ferry. (Continued)**



ITEM NO.	INTERVAL	MAN-HOURS	ITEM TO BE CHECKED OR SERVICED	PROCEDURE	EQUIPMENT NOT READY/ AVAILABLE IF:
<p>WARNING</p> <div style="display: flex; justify-content: space-around; align-items: center;"> <div style="text-align: center;">  <p>CHEMICAL</p> </div> <div style="text-align: center;">  <p>EYE PROTECTION</p> </div> </div> <p>NOTE</p> <p>Most starters do not require any lubrication between overhauls.</p>					
20	Semi-annually	0.1	Diesel Engine (Starter)	<p>1. Lubricate starters equipped with hinge type oilers with 8 to 10 drops of lubricating oil (grade 40) and a hand oiler.</p> <p>2. Lubricate starters equipped with grease cups by turning the grease cups down one turn. Refill grease cups as necessary with automotive and artillery grease by hand.</p> <p>3. Lubricate starters equipped with sealed tubes by removing the pipe plugs, adding 8 to 10 drops of lubricating oil (grade 40) with a hand oiler. Reseal the tubes with the pipe plugs.</p>	
28	Semi-annually	0.5	Hydraulic System	Perform AOAP sampling as prescribed by DA PAM 738-750.	
2	Semi-annually	0.5	Powered and Non-Powered Modules (Zinc Anodes)	Inspect Zinc anodes, if 75% depleted contact unit maintenance.	Zinc Anodes 75% depleted
35	Annually	2.0	Fire Suppression System	Inspect fire suppression system in accordance with 46 CFR Parts 91.25-20 and 97.15-60. Contact Specialized Repair Activity (SRA).	
32	Annually	0.1	Fuel System Access	Torque Fuel System Access Cover bolts.	
11	Annually	0.1	Main Mast Winch	Torque Main Mast Winch cable clamp bolts to 20-30 in. lb.	

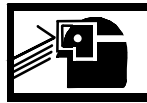
Table 1. Preventive Maintenance Checks and Services for the Causeway Ferry. (Continued)

ITEM NO.	INTERVAL	MAN-HOURS	ITEM TO BE CHECKED OR SERVICED	PROCEDURE	EQUIPMENT NOT READY/ AVAILABLE IF:
41	Annually	2.0	Weight Lifting Devices	Anneal all steel weight lifting chains, rings, hooks, shackles and swivels per 29 CFR Parts 1919.16 and 1919.36. Contact Specialized Repair Activity (SRA).	

WARNING

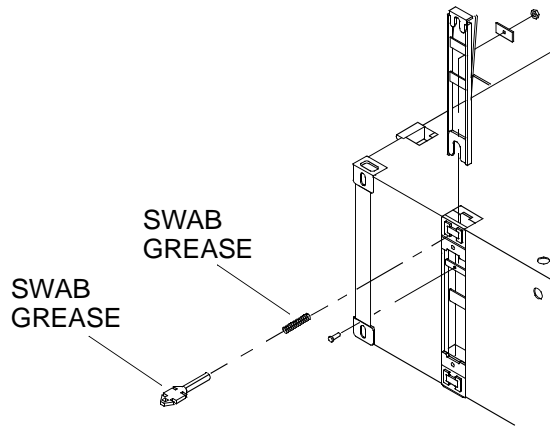


CHEMICAL





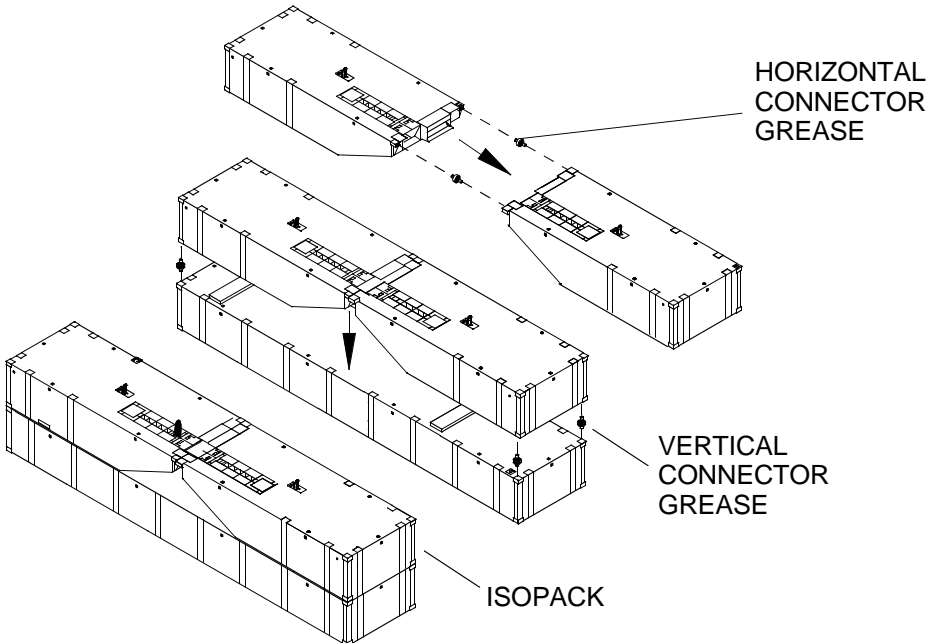
EYE PROTECTION

42	Annually	0.3 each assembly	Module Interlock Connector and Spring	Lubricate annually and On Condition (before and after operation). Lubricate with general purpose grease by hand.	
----	----------	-------------------	---------------------------------------	--	--



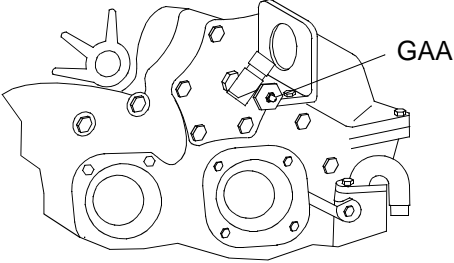






INTERLOCK CONNECTOR SPRING PIN



Table 1. Preventive Maintenance Checks and Services for the Causeway Ferry. (Continued)

ITEM NO.	INTERVAL	MAN-HOURS	ITEM TO BE CHECKED OR SERVICED	PROCEDURE	EQUIPMENT NOT READY/ AVAILABLE IF:
<p>WARNING</p> <div style="display: flex; justify-content: space-around; align-items: center;"> <div style="text-align: center;">  <p>CHEMICAL</p> </div> <div style="text-align: center;">  <p>EYE PROTECTION</p> </div> </div>					
43	Annually	0.1 each connector	Horizontal and Vertical Connectors	Lubricate annually and on condition (before and after operation). Lubricate with general purpose grease by hand.	
 <p>HORIZONTAL AND VERTICAL CONNECTORS - MODULES</p>					
20	Annually 500 Hours	0.1	Diesel Engine	<ol style="list-style-type: none"> 1. Check oil and fuel lines for chafing and leaking. If chafing or leakage is found, contact unit maintenance. 2. Check oil and fuel hoses for signs of deterioration. If signs of deterioration are found, contact unit maintenance. 	<p>Class I fuel or Class III oil leakage is found.</p> <p>Class I fuel or Class III oil leakage is found.</p>

■ Table 1. Preventive Maintenance Checks and Services for the Causeway Ferry. (Continued)

ITEM NO.	INTERVAL	MAN-HOURS	ITEM TO BE CHECKED OR SERVICED	PROCEDURE	EQUIPMENT NOT READY/ AVAILABLE IF:
<p>WARNING</p> <div style="display: flex; justify-content: space-around;">   </div> <div style="display: flex; justify-content: space-around;"> <p>CHEMICAL</p> <p>EYE PROTECTION</p> </div>					
20	100 Hours	0.2	Diesel Engine (Tachometer Drive)	Lubricate engine tachometer drive. Use automotive and artillery grease and a hand lubricating gun.	
					
<p>WARNING</p> <div style="display: flex; justify-content: space-around;">   </div> <div style="display: flex; justify-content: space-around;"> <p>CHEMICAL</p> <p>EYE PROTECTION</p> </div>					
20	200 Hours	0.1	Diesel Engine (Throttle and Clutch Controls)	Lubricate the engine throttle and clutch controls. Lubricate with automotive and artillery grease by hand.	
<p>WARNING</p> <div style="display: flex; justify-content: space-around;">   </div> <div style="display: flex; justify-content: space-around;"> <p>CHEMICAL</p> <p>EYE PROTECTION</p> </div>					
25	300 Hours	2.0	Marine Gear	Lubricate marine gear output seal. Use automotive and artillery grease and a hand lubricating gun.	

■ **Table 1. Preventive Maintenance Checks and Services for the Causeway Ferry. (Continued)**

ITEM NO.	INTERVAL	MAN-HOURS	ITEM TO BE CHECKED OR SERVICED	PROCEDURE	EQUIPMENT NOT READY/ AVAILABLE IF:
<p>WARNING</p> <div style="display: flex; justify-content: space-around; align-items: center;"> <div style="text-align: center;">  <p>CHEMICAL</p> </div> <div style="text-align: center;">  <p>EYE PROTECTION</p> </div> </div>					
20	500 Hours	1.0	Diesel Engine	Lubricate the overspeed governor, if equipped with a hinge cap oiler or oil cup, with five to six drops of engine oil. Use lubricating oil (grade 30) and hand oiler.	

END OF WORK PACKAGE

CHAPTER 5

OPERATOR SUPPORTING INFORMATION
FOR
MODULAR CAUSEWAY SYSTEM (MCS)
CAUSEWAY FERRY (CF)

**UNIT, DIRECT SUPPORT AND GENERAL SUPPORT MAINTENANCE
CAUSEWAY FERRY
REFERENCES**

SCOPE

This work package lists all field manuals, forms, technical manuals and miscellaneous publications referenced in this manual.

ARMY REGULATIONS

AR 700-138 Army Logistics Readiness and Sustainability

CODE OF FEDERAL REGULATIONS

29 CFR Labor, Parts 1911 to 1925

46 CFR Shipping, Parts 90 to 139

DA PAMPHLETS

DA PAM 738-750 The Army Maintenance Management Systems (TAMMS)

FIELD MANUALS

FM 3-4 NBC, Protection

FM 3-5 NBC, Decontamination

FM 55-502 Army Watercraft Safety

FORMS

DA Form 2028 Recommended Changes to Publications and Blank Forms

DA Form 2404 Equipment Inspection and Maintenance Worksheet

SF 368 Product Quality Deficiency Report

MISCELLANEOUS

ASME Y14.38-1999 The American Society of Mechanical Engineers Abbreviations and Acronyms

CTA 8-100 Common Table of Allowances, Army Medical Department
Expendable/Durable Items

CTA 50-970 Common Table of Allowances, Expendable/Durable Items (Except
Medical, Class V Repair Parts, and Heraldic Items)

SUPPLY CATALOG

SC 4910-95-A68 Shop Equipment, Automotive Equipment and Repair, Field Maintenance
SC 4910-95-A72 Shop Equipment, Automotive Equipment and Repair, Organizational Maintenance

TECHNICAL MANUALS

TM 5-2815-258-10 Operators Manual for Detroit Diesel Engine Series 53
TM 5-2815-258-24 Unit, Direct Support and General Maintenance Manual for Detroit Diesel Engine Series 53
TM 9-6115-643-24 Unit, Direct Support and General Maintenance Manual for Generator Set, Skid Mounted, Tactical Quiet 15KW
TM 9-6140-200-14 Operators, Unit, Direct Support and General Support Maintenance Manual for Lead-Acid Storage Batteries
TM 11-5820-890-10-8 SINGARS Operators Manual
TM 11-5825-291-13 Operations and Maintenance Manual, Satellite Signals Navigation Sets
TM 55-1925-257-14&P Operator, Unit, Direct Support and General Support Maintenance Manual for Incinerator Toilet/Urinal, Galley Equipment and Electric Water Heater
TM 55-3950-204-14&P Unit, Direct Support and General Maintenance Manual for Winch, Warming Tug
TM 750-244-6 Destruction of TACOM Equipment

**OPERATOR MAINTENANCE
CAUSEWAY FERRY
MAINTENANCE ALLOCATION CHART (MAC)**

INTRODUCTION

The Army Maintenance System MAC

This introduction provides a general explanation of all maintenance and repair functions authorized at various levels under the standard Army Maintenance System concept.

The MAC (immediately following the introduction) designates overall authority and responsibility for the performance of maintenance functions on the identified end item or component. The application of the maintenance functions to the end item or component shall be consistent with the capacities of the designated maintenance levels, which are shown on the MAC in column (4) as:

Unit - includes two subcolumns, C (operator/crew) and O (unit) maintenance.

Direct Support - includes an F subcolumn.

General Support - includes an H subcolumn.

Depot - includes a D subcolumn.

The tools and test equipment requirements, immediately following the MAC, if applicable, list the tools and test equipment, both special tools and common tool sets, required for each maintenance function as referenced from the MAC.

The remarks, immediately following the tools and test equipment requirements, if applicable, contain supplemental instructions and explanatory notes for a particular maintenance function.

Maintenance Functions

Maintenance functions are limited to and defined as follows:

1. Inspect. To determine the serviceability of an item by comparing its physical, mechanical and/or electrical characteristics with established standards through examination, e.g., by sight, sound or feel. This includes scheduled inspection and gaugings and evaluation of cannon tubes.
2. Test. To verify serviceability by measuring the mechanical, pneumatic, hydraulic or electrical characteristics of an item and comparing those characteristics with prescribed standards on a scheduled basis, i.e., load testing of lift devices and hydrostatic testing of pressure hoses.
3. Service. Operations required periodically to keep an item in proper operating conditions; e.g., to clean, includes decontaminate, when required, to preserve, to drain, to paint or to replenish fuel, lubricants, chemical fluids or gases. This includes scheduled exercising and purging of recoil mechanisms.
4. Adjust. To maintain or regulate, within prescribed limits, by bringing into proper position, or by setting the operating characteristics to specified parameters.
5. Align. To adjust specified variable elements of an item to bring about optimum or desired performance.

6. Calibrate. To determine and cause corrections to be made or to be adjusted on instruments or test, measuring and diagnostic equipment used in precision measurement. Consists of comparisons of two instruments, one of which is a certified standard of known accuracy, to detect and adjust any discrepancy in the accuracy of the instrument being compared.
7. Remove/Install. To remove and install the same item when required to perform service or other maintenance functions. Install may be the act of emplacing, seating or fixing into position a spare, repair part or module (component or assembly) in a manner to allow the proper functioning of an equipment or system.
8. Replace. To remove an unserviceable item and install a serviceable counterpart in its place. "Replace" is authorized by the MAC and assigned maintenance level is shown as the third position code of the Source, Maintenance and Recoverability (SMR) code.
9. Repair. The application of the maintenance services, including fault location/troubleshooting, removal/installation, disassembly/assembly procedures and maintenance actions to identify troubles and restore serviceability to an item by correcting specific damage, fault, malfunction or failure in a part, subassembly, module (component or assembly), end item or system.

NOTE

The following definitions are applicable to the "repair" maintenance function:

Services - inspect, test, service, adjust, align, calibrate and/or replace.

Fault location/troubleshooting - the process of investigating and detecting the cause of equipment malfunctioning; the act of isolating a fault within a system or Unit Under Test (UUT).

Disassembly/assembly - the step-by-step breakdown (taking apart) of a spare/functional group coded item to the level of its least component, that is assigned an SMR code for the level of maintenance under consideration (i.e., identified as maintenance significant).

Actions - welding, grinding, riveting, straightening, facing, machining and/or resurfacing.

10. Overhaul. That maintenance effort (service/action) prescribed to restore an item to a completely serviceable/operational condition as required by maintenance standards in appropriate technical publications. Overhaul is normally the highest degree of maintenance performed by the Army. Overhaul does not normally return an item to like new condition.
11. Rebuild. Consists of those services/actions necessary for the restoration of unserviceable equipment to a like new condition in accordance with original manufacturing standards. Rebuild is the highest degree of maintenance applied to Army equipment. The rebuild operation includes the act of returning to zero those age measurements (e.g., hours/miles) considered in classifying Army equipment/components.

Explanation of Columns in the MAC

Column (1) - Group Number. Column (1) lists FGC numbers, the purpose of which is to identify maintenance significant components, assemblies, subassemblies, and modules with the Next Higher Assembly (NHA).

Column (2) - Component/Assembly. Column (2) contains the item names of components, assemblies, subassemblies and modules for which maintenance is authorized.

Column (3) - Maintenance Function. Column (3) lists the functions to be performed on the item listed in column (2). For a detailed explanation of these functions refer to "Maintenance Functions" outlined above.

Column (4) - Maintenance Level. Column (4) specifies each level of maintenance authorized to perform each function listed in column (3), by indicating work time required (expressed as manhours in whole hours or decimals) in the appropriate subcolumn. This work time figure represents the active time required to perform that maintenance function at the indicated level of maintenance. If the number or complexity of the tasks within the listed maintenance function varies at different maintenance levels, appropriate work time figures are to be shown for each level. The work time figures represent the average time required to restore an item (assembly, subassembly, component, module, end item or system) to a serviceable condition under typical field operating conditions. This time includes preparation time (including any necessary disassembly/assembly time), troubleshooting/fault location time, and quality assurance time in addition to the time required to perform the specific tasks identified for the maintenance functions authorized in the MAC. The symbol designations for the various maintenance levels are as follows:

C - Operator or crew maintenance

O - Unit maintenance

F - Direct support maintenance

L - Specialized Repair Activity (SRA)

H - General support maintenance

D - Depot maintenance

NOTE

The "L" maintenance level is not included in column (4) of the MAC. Functions to this level of maintenance are identified by a work time figure in the "H" column of column (4) and an associated reference code is used in the remarks column (6). This code is keyed to the remarks and the SRA complete repair application is explained there.

Column (5) - Tools and Equipment Reference Code. Column (5) specifies, by code, those common tool sets (not individual tools), common Test, Measurement and Diagnostic Equipment (TMDE), and special tools, special TMDE and special support equipment required to perform the designated function. Codes are keyed to the entries in the tools and test equipment table.

Column (6) - Remarks Code. When applicable, this column contains a letter code, in alphabetical order, which is keyed to the remarks table entries.

Explanation of Columns in the Tools and Test Equipment Requirements

Column (1) - Tool or Test Equipment Reference Code. The tool or test equipment reference code correlates with a code used in column (5) of the MAC.

Column (2) - Maintenance Level. The lowest level of maintenance authorized to use the tool or test equipment.

Column (3) - Nomenclature. Name or identification of the tool or test equipment.

Column (4) - National Stock Number (NSN). The NSN of the tool or test equipment.

Column (5) - Tool Number. The manufacturer's part number, model number or type number.

Explanation of the Columns in the Remarks

Column (1) - Remarks Code. The code recorded in column (6) of the MAC.

Column (2) - Remarks. This column lists information pertinent to the maintenance function being performed as indicated in the MAC.

**OPERATOR MAINTENANCE
CAUSEWAY FERRY
MAINTENANCE ALLOCATION CHART**

MAINTENANCE ALLOCATION CHART

Table 1. MAC for Modular Causeway System. (MCS)

(1) GROUP NO.	(2) COMPONENT/ASSEMBLY	(3) MAINTENANCE FUNCTION	(4) MAINTENANCE LEVEL				(5) TOOLS AND EQUIP REF CODE	(6) REMARKS CODE	
			UNIT		DS	GS			DEPOT
			C	O	F	H			D
00	MODULAR CAUSEWAY SYSTEM (MCS)								
01	CAUSEWAY FERRY (CF)								
0101	POWERED SECTION								
010101	POWERED MODULE								
01010101	DRIVE TRAIN								
0101010101	DIESEL ENGINE							A	
0101010102	MARINE GEAR							B	
0101010103	TRANSFER CASE							C	
0101010104	PUMP-JET	Inspect	0.5					E	
		Service		3.0			1	E	
		Repair				10.0		D	
		Replace				50.0		D	
010101010401	HYDRAULIC SYSTEM	Inspect	1.0					E	
		Service	1.0	3.0			1	E	
		Repair			3.0		2, 4, 7		
		Replace			6.0		2, 4, 7		
01010101040101	HYDRAULIC PUMP	Test	0.5					E	
		Inspect	1.0					E	
		Repair				4.0	2, 4, 7	E	

Table 1. MAC for Modular Causeway System. (MCS) (Continued)

(1) GROUP NO.	(2) COMPONENT/ASSEMBLY	(3) MAINTENANCE FUNCTION	(4) MAINTENANCE LEVEL					(5) TOOLS AND EQUIP REF CODE	(6) REMARKS CODE
			UNIT		DS	GS	DEPOT		
			C	O	F	H	D		
01010101040101	HYDRAULIC PUMP (CONT'D)	Replace		6.0				1, 2, 4	
01010101040102	HYDRAULIC HAND PUMP	Inspect	1.0						E
		Repair					20.0		
		Replace		2.0				1, 2, 4	
01010101040103	HYDRAULIC WAY-VALVE	Repair				2.0		2, 4, 7	
		Replace		1.5				1, 2, 4	
010101010403	FEEDBACK UNIT	Inspect	1.0						E
		Repair				2.5		2, 4, 7	
		Replace			2.0			2, 4, 7	
0101010105	ALTERNATOR	Test			1.0			7, 14, 15	E
		Inspect	0.5						E
		Replace			2.0			7, 14, 15	
01010102	ENGINE EXHAUST SYSTEM	Clean		2.0				1, 3, 9	E
		Inspect		2.0				1, 3, 9	E
		Repair			6.0			3, 7, 9	
01010103	BILGE PUMP	Test		2.0				1	E
		Inspect	1.0						E
		Replace		8.0				1	F
01010104	FIRE SUPPRESSION SYSTEM	Test					3.0		E
		Inspect	2.0				3.0		E
		Repair					8.0		G
		Replace					24.0		G

Table 1. MAC for Modular Causeway System. (MCS) (Continued)

(1) GROUP NO.	(2) COMPONENT/ASSEMBLY	(3) MAINTENANCE FUNCTION	(4) MAINTENANCE LEVEL					(5) TOOLS AND EQUIP REF CODE	(6) REMARKS CODE
			UNIT		DS	GS	DEPOT		
			C	O	F	H	D		
01010105	FUEL SYSTEM	Test	1.0						E
		Inspect	1.0						E
		Repair			4.0			7	
		Replace			12.0			7	
0101010501	FUEL/WATER SEPARATOR	Clean	1.0						E
		Inspect	1.0						E
		Repair		2.0				1	
		Replace			4.0			7	
01010106	ELECTRICAL SYSTEM	Test			1.0			7, 14, 15	E
		Adjust			1.0			7, 14, 15	
		Repair			2.0			7, 14, 15	
		Replace			8.0			7, 14, 15	
01010107	EMERGENCY STEERING SYSTEM	Inspect	2.0						E
		Service	1.0						E
		Replace		4.0				1	
0101010701	STEERING UNIT	Inspect	0.5						E
		Replace		2.0				1, 2	
0101010702	STEERING ADAPTOR	Inspect	0.5						E
		Replace		1.5				1	
01010108	HULL								
0101010801	EXTERIOR	Clean		4.0				8, 9, 23, 24	E
		Inspect	1.0						E
		Service	1.5						E

Table 1. MAC for Modular Causeway System. (MCS) (Continued)

(1) GROUP NO.	(2) COMPONENT/ASSEMBLY	(3) MAINTENANCE FUNCTION	(4) MAINTENANCE LEVEL					(5) TOOLS AND EQUIP REF CODE	(6) REMARKS CODE	
			UNIT		DS	GS	DEPOT			
			C	O	F	H	D			
0101010801	EXTERIOR (CONT'D)	Repair		4.0				1, 16		
		Overhaul					24.0			
0101010802	INTERIOR	Clean					4.0			
		Inspect					2.0			
		Test		8.0				5.0	1, 25, 26	E
		Repair						6.0		
		Overhaul						50.0		
01010109	GUILLOTINE FITTINGS	Clean		1.0				8, 9, 23, 24	E	
		Inspect	0.5						E	
		Repair		3.0				1, 16		
		Replace		1.0				1		
01010110	HATCHES & HINGES	Clean	1.0					8, 9, 23, 24	E	
		Inspect	0.5						E	
		Service	0.5						E	
		Repair		2.0				1, 16		
		Replace		2.0				1		
0101010111	FLEXORS	Inspect	0.5						E	
		Replace	4.0							
010102	NON-POWERED MODULES									
01010201	HULL									
0101020101	EXTERIOR	Clean		4.0				8, 9, 23, 24	E	
		Inspect	1.0						E	
		Service	1.5						E	

Table 1. MAC for Modular Causeway System. (MCS) (Continued)

(1) GROUP NO.	(2) COMPONENT/ASSEMBLY	(3) MAINTENANCE FUNCTION	(4) MAINTENANCE LEVEL					(5) TOOLS AND EQUIP REF CODE	(6) REMARKS CODE
			UNIT		DS	GS	DEPOT		
			C	O	F	H	D		
0101020101	EXTERIOR (CONT'D)	Repair		4.0				1, 16	
		Overhaul					24.0		
0101020102	INTERIOR	Clean					4.0		
		Inspect					2.0		
		Test					5.0	1, 25, 26	E
		Repair					6.0		
		Overhaul					50.0		
01010202	GUILLOTINE FITTINGS	Clean		1.0				8, 9, 23, 24	E
		Inspect	0.5						E
		Repair		3.0				1, 16	
		Replace		1.0				1	
01010203	FLEXORS	Inspect	0.5						E
		Replace	4.0						
010103	OPERATORS CAB								
01010301	MIDDLE CONTROL PANEL	Test			2.0			7, 14, 15	E
		Inspect			2.0			7, 14, 15	E
		Repair			3.0			7, 14, 15	
		Replace			16.0			7, 14, 15	
01010302	LOWER CONTROL PANEL	Test			2.0			7, 14, 15	E
		Inspect			2.0			7, 14, 15	E
		Repair			3.0			7, 14, 15	
		Replace			16.0			7, 14, 15	

Table 1. MAC for Modular Causeway System. (MCS) (Continued)

(1) GROUP NO.	(2) COMPONENT/ASSEMBLY	(3) MAINTENANCE FUNCTION	(4) MAINTENANCE LEVEL					(5) TOOLS AND EQUIP REF CODE	(6) REMARKS CODE
			UNIT		DS	GS	DEPOT		
			C	O	F	H	D		
01010303	CIRCUIT BREAKER PANEL	Test			1.0			7, 14, 15	E
		Inspect			1.0			7, 14, 15	E
		Repair			2.0			7, 14, 15	
		Replace			12.0			7, 14, 15	
01010304	TERMINAL STRIP A-4	Test			1.0			7, 14, 15	E
		Inspect			1.0			7, 14, 15	E
		Repair			2.0			7, 14, 15	
		Replace			10.0			7, 14, 15	
01010305	SPOTLIGHT	Adjust		1.0				1	
		Replace		1.0				1	
01010306	DEFROSTER	Inspect	1.0						E
		Replace			4.0			7, 14, 15	
01010307	HEATER	Inspect		2.0				1	
		Repair			4.0			7, 14, 15	
		Replace			6.0			7, 14, 15	
01010308	WINDSHIELD WIPER	Repair		1.0				1	
		Replace		2.0				1	
01010309	COMMUNICATIONS EQUIPMENT								
0101030901	VHF/FM HANDHELD TRANSCEIVER	Repair					8.0		
		Replace		1.0				1	

Table 1. MAC for Modular Causeway System. (MCS) (Continued)

(1) GROUP NO.	(2) COMPONENT/ASSEMBLY	(3) MAINTENANCE FUNCTION	(4) MAINTENANCE LEVEL				(5) TOOLS AND EQUIP REF CODE	(6) REMARKS CODE	
			UNIT		DS	GS			DEPOT
			C	O	F	H			D
0101030902	AN/PSN-11 INTERFACE & SWITCHBOX	Repair					6.0		
		Replace			1.0			7, 14, 15	
0101030903	LOUDHAILER	Repair					8.0		
		Replace	0.5						
0101030904	SINGARS RADIO								H
0101030905	VHF/FM DCS TRANSCEIVER	Repair					12.0		
		Replace		1.0				1	
01010310	NAVIGATION EQUIPMENT	Test	0.5						E
		Inspect	1.0						E
0101031001	COMPASS	Inspect	2.0.						E
		Replace		2.0				1	
		Calibrate		4.0				1	E
0101031002	PLGR								I
01010311	MAST	Inspect	3.0						E
		Repair		3.0				1	
0101031101	NAVIGATION LIGHTS	Repair		1.0				1	
		Replace		1.0				1	
0101312	OPERATORS CAB ELECTRICAL SYSTEM	Test			4.0			7, 14, 15	E
		Inspect			4.0			7, 14, 15	E
		Repair				6.0		7, 14, 15	
		Replace			10.0			7, 14, 15	

Table 1. MAC for Modular Causeway System. (MCS) (Continued)

(1) GROUP NO.	(2) COMPONENT/ASSEMBLY	(3) MAINTENANCE FUNCTION	(4) MAINTENANCE LEVEL					(5) TOOLS AND EQUIP REF CODE	(6) REMARKS CODE
			UNIT		DS	GS	DEPOT		
			C	O	F	H	D		
010104	ANCHOR ASSEMBLY	Inspect	1.0						E
		Repair		1.0				1	
		Replace		1.0				1	
0102	INTERMEDIATE SECTION								
010201	NON-POWERED MODULES								
01020101	HULL								
0102010101	EXTERIOR	Clean		4.0				8, 9, 23, 24	E
		Inspect	1.0						E
		Service	1.5						E
		Repair		4.0				1, 16	
		Overhaul					24.0		
0102010102	INTERIOR	Clean					4.0		
		Inspect					2.0		
		Test		8.0			5.0	1, 25, 26	E
		Repair					6.0		
		Overhaul					50.0		
01020102	GUILLOTINE FITTINGS	Clean		1.0				8, 9, 23, 24	E
		Inspect	0.5						E
		Repair		3.0				1, 16	
		Replace		1.0				1	
01020103	FLEXORS	Inspect	0.5						E
		Replace	4.0						

Table 1. MAC for Modular Causeway System. (MCS) (Continued)

(1) GROUP NO.	(2) COMPONENT/ASSEMBLY	(3) MAINTENANCE FUNCTION	(4) MAINTENANCE LEVEL					(5) TOOLS AND EQUIP REF CODE	(6) REMARKS CODE
			UNIT		DS	GS	DEPOT		
			C	O	F	H	D		
0103	CAUSEWAY FERRY BEACH- END SECTION								
010301	NON-POWERED MODULE								
01030101	HULL								
0103010101	EXTERIOR	Clean		4.0				8, 9, 23, 24	E
		Inspect	1.0						E
		Service	1.5						E
		Repair		4.0				1, 16	
		Overhaul					24.0		
0103010102	INTERIOR	Clean					4.0		
		Inspect					2.0		
		Test		8.0			5.0	1, 25, 26	E
		Repair					6.0		
		Overhaul					50.0		
01030102	GUILLOTINE FITTINGS	Clean		1.0				8, 9, 23, 24	E
		Inspect	0.5						E
		Repair		3.0				1, 16	
		Replace		1.0				1	
01030103	FLEXORS	Inspect	0.5						E
		Replace	4.0						
0104	CONTAINERS	Clean	1.0						E
		Inspect	2.0						E
		Repair			4.0			7	
		Replace					8.0		

Table 1. MAC for Modular Causeway System. (MCS) (Continued)

(1) GROUP NO.	(2) COMPONENT/ASSEMBLY	(3) MAINTENANCE FUNCTION	(4) MAINTENANCE LEVEL					(5) TOOLS AND EQUIP REF CODE	(6) REMARKS CODE
			UNIT		DS	GS	DEPOT		
			C	O	F	H	D		

Table 1. MAC for Modular Causeway System. (MCS) (Continued)

(1) GROUP NO.	(2) COMPONENT/ASSEMBLY	(3) MAINTENANCE FUNCTION	(4) MAINTENANCE LEVEL					(5) TOOLS AND EQUIP REF CODE	(6) REMARKS CODE
			UNIT		DS	GS	DEPOT		
			C	O	F	H	D		
00	MODULAR CAUSEWAY SYSTEM (MCS)								
01	CAUSEWAY FERRY (CF)								
0101010101	DIESEL ENGINE	Inspect	4.0					E	
		Service	4.0	4.0				E	
		Repair				30.0		7, 27-218	
		Replace			120.0			7, 27-218	
		Overhaul					80.0		
010101010101	ENGINE BLOCK ASSEMBLY	Inspect	2.0					E, J	
		Repair				6.0		7, 27-52 J	
		Replace				120.0		7, 27-52 J	
010101010102	CYLINDER HEAD ASSEMBLY	Clean				5.0		7, 53-85 E, K	
		Repair				12.0		7, 53-85 K	
		Inspect			6.0			7, 53-85 E, K	
		Replace			8.0			7, 53-85 K	
010101010103	CRANKSHAFT ASSEMBLY	Repair			16.0			7, 86-106 L	
		Replace			24.0			7, 86-106 L	
010101010104	CAMSHAFT ASSEMBLY	Repair				12.0		7, 131-141	
		Replace				16.0		7, 131-141	
010101010105	FLYWHEEL ASSEMBLY	Inspect			3.0			7, 107-112 M	
		Replace			5.0			7, 107-112 M	

Table 1. MAC for Modular Causeway System. (MCS) (Continued)

(1) GROUP NO.	(2) COMPONENT/ASSEMBLY	(3) MAINTENANCE FUNCTION	(4) MAINTENANCE LEVEL					(5) TOOLS AND EQUIP REF CODE	(6) REMARKS CODE	
			UNIT		DS	GS	DEPOT			
			C	O	F	H	D			
010101010106	PISTON ASSEMBLY	Clean				2.0		7, 113-130	N	
		Repair				3.0		7, 107-112	M	
		Inspect				2.0		7, 113-130	N	
		Rebuild				4.5		7, 113-130	N	
		Replace				3.0		7, 113-130	N	
010101010107	ENGINE BALANCE	Inspect				6.0		7, 131-141	O	
		Adjust				3.0		7, 131-141	O	
		Replace				8.0		7, 131-141	O	
		Repair				8.0		7, 131-141	O	
010101010108	FUEL SYSTEM	Inspect	0.5						E, P	
01010101010801	FUEL PUMP	Inspect				1.0		7, 142-187	E	
		Repair				4.0		7, 142-187		
		Replace				2.0		7, 142-187		
01010101010802	PRIMING PUMP	Inspect		1.5				1, 142-187	E	
		Replace		2.0				1, 142-187		
010101010109	ELECTRIC GOVERNOR	Test				0.5				E
		Adjust		1.0				7, 142-187		
		Repair					5.0			
		Replace		2.0				1, 142-187		
		Inspect	0.5							E, Q
010101010110	AIR INTAKE SYSTEM	Clean		2.0				1, 188-195	E, Q	
		Replace		3.0				1, 188-195	Q	

Table 1. MAC for Modular Causeway System. (MCS) (Continued)

(1) GROUP NO.	(2) COMPONENT/ASSEMBLY	(3) MAINTENANCE FUNCTION	(4) MAINTENANCE LEVEL					(5) TOOLS AND EQUIP REF CODE	(6) REMARKS CODE
			UNIT		DS	GS	DEPOT		
			C	O	F	H	D		
01010101011001	BLOWER	Inspect			2.0	2.0		7, 188-195	E
		Adjust				4.0		7, 188-195	
		Repair				18.0		7, 188-195	
01010101011002	TURBOCHARGER	Inspect		2.0				1, 188-195	E, R
		Replace			8.0			7, 188-195	
		Repair					18.0		
		Replace			6.0			7, 188-195	
010101010111	LUBE OIL SYSTEM	Service	5.0	5.0					E, S
		Inspect	1.0						E
01010101011101	LUBE OIL PUMP	Inspect				3.0		7, 196-203	E
		Repair				4.0		7, 196-203	
		Replace				4.0		7, 196-203	
01010101011102	LUBE OIL COOLER	Clean			2.0			7	E
		Test			1.5			7, 25, 26	E
		Inspect			2.0			7	E
		Repair			4.0			7	E
		Replace			2.0			7	
010101010112	FRESH WATER COOLING SYSTEM	Inspect	1.0						E, T
		Clean		1.0				1	
01010101011201	FRESH WATER PUMP	Inspect			2.5			7, 212-215	E
		Repair			6.0			7, 212-215	
		Replace			3.0			7, 212-215	
		Test			2.0			7, 25, 26	E

Table 1. MAC for Modular Causeway System. (MCS) (Continued)

(1) GROUP NO.	(2) COMPONENT/ASSEMBLY	(3) MAINTENANCE FUNCTION	(4) MAINTENANCE LEVEL					(5) TOOLS AND EQUIP REF CODE	(6) REMARKS CODE
			UNIT		DS	GS	DEPOT		
			C	O	F	H	D		
01010101011202	FRESH WATER COOLER	Clean			2.0			7	E
		Inspect			1.0			7	E
		Repair			4.0			7	
		Replace			3.0			7	
010101010113	RAW WATER COOLING SYSTEM	Inspect	1.0					E, U	
01010101011301	RAW WATER PUMP	Inspect		2.0				1	E
		Clean		2.0				1	E, U
		Repair			4.0			7, 212-215	
		Replace		2.5				1, 212-215	
010101010114	ELECTRICAL SYSTEM	Test			4.0			7, 14, 15	E, V
		Inspect			2.0			7, 14, 15	E, V
		Repair			3.0			7, 14, 15	V
		Replace			16.0			1, 7, 14, 15	V
01010101011401	STARTER	Inspect	1.0						E
		Repair				6.0		7, 14, 15	
		Replace		3.0				1, 14, 15	
01010101011402	COLD PACK STARTER	Clean		1.0				1	E
		Inspect	0.5						E
		Adjust		1.0				1, 14, 15	
		Repair		2.5				1, 14, 15	
		Replace		3.0				1, 14, 15	

Table 1. MAC for Modular Causeway System. (MCS) (Continued)

(1) GROUP NO.	(2) COMPONENT/ASSEMBLY	(3) MAINTENANCE FUNCTION	(4) MAINTENANCE LEVEL					(5) TOOLS AND EQUIP REF CODE	(6) REMARKS CODE
			UNIT		DS	GS	DEPOT		
			C	O	F	H	D		
010101010115	OVER SPEED GOVERNOR	Test				1.0		7	E
		Adjust				1.5		7, 184-187	
		Repair				5.0		7, 184-187	
		Replace				4.0		7, 184-187	
010101010116	AUTO SHUTDOWN SYSTEM	Test		1.0					E
		Adjust			2.0			7, 14, 15	
		Repair				6.0		7, 14, 15	
		Replace		4.0			8.0	1	

Table 1. MAC for Modular Causeway System. (MCS) (Continued)

(1) GROUP NO.	(2) COMPONENT/ASSEMBLY	(3) MAINTENANCE FUNCTION	(4) MAINTENANCE LEVEL					(5) TOOLS AND EQUIP REF CODE	(6) REMARKS CODE
			UNIT		DS	GS	DEPOT		
			C	O	F	H	D		

Table 1. MAC for Modular Causeway System. (MCS) (Continued)

(1) GROUP NO.	(2) COMPONENT/ASSEMBLY	(3) MAINTENANCE FUNCTION	(4) MAINTENANCE LEVEL					(5) TOOLS AND EQUIP REF CODE	(6) REMARKS CODE
			UNIT		DS	GS	DEPOT		
			C	O	F	H	D		
00	MODULAR CAUSEWAY SYSTEM (MCS)								
01	CAUSEWAY FERRY (CF)								
0101010102	MARINE GEAR	Inspect	1.0					E	
		Align			2.0		7, 17		
		Service	1.0	4.0			1	E	
		Rebuild				25.0		W	
		Replace			28.0		4, 7, 17		
010101010201	OIL SYSTEM	Inspect	0.5					E, X	
		Repair		.5			1, 11	X	
01010101020101	OIL COOLER	Clean	1.0					E	
		Inspect	1.0					E	
		Replace		4.0			1		
01010101020102	LINES & HOSES	Inspect	0.5					E	
		Repair		1.0			1		
01010101020103	OIL PUMP	Inspect	1.0					E	
		Repair		2.0			1, 3		
01010101020104	ELECTRIC CONTROL VALVE	Repair				8.0			
		Replace			6.0		7, 14, 15		
010101010202	GEAR MOUNTS	Inspect	.05					E	
		Replace			2.0		3,7		
010101010203	COUPLING BLOCKS	Clean			1.0		7	E	
		Inspect			1.0		7	E	
		Replace			4.0		3, 7		

Table 1. MAC for Modular Causeway System. (MCS) (Continued)

(1) GROUP NO.	(2) COMPONENT/ASSEMBLY	(3) MAINTENANCE FUNCTION	(4) MAINTENANCE LEVEL					(5) TOOLS AND EQUIP REF CODE	(6) REMARKS CODE
			UNIT		DS	GS	DEPOT		
			C	O	F	H	D		
010101010204	OUTPUT FLANGE	Inspect	0.5						E
		Align			2.0			3, 7, 17	
		Replace			4.0			3, 7, 17	
010101010205	OUTPUT SEAL	Inspect			2.0			7	E
		Replace			2.0			3, 7	
010101010206	INPUT FLANGE (ENGINE CONNECTION)	Inspect	0.5						E

Table 1. MAC for Modular Causeway System. (MCS) (Continued)

(1) GROUP NO.	(2) COMPONENT/ASSEMBLY	(3) MAINTENANCE FUNCTION	(4) MAINTENANCE LEVEL					(5) TOOLS AND EQUIP REF CODE	(6) REMARKS CODE
			UNIT		DS	GS	DEPOT		
			C	O	F	H	D		
00	MODULAR CAUSEWAY SYSTEM (MCS)								
01	CAUSEWAY FERRY (CF)								
0101010103	TRANSFER CASE	Clean		2.0				1	E
		Service	1.0	4.0				1	E
		Overhaul				24.0			
		Rebuild					24.0	2, 7, 17	Y
		Replace			24.0			2, 7, 17	
010101010301	OIL SYSTEM	Inspect	1.0						E
		Repair		2.5				1	
01010101030101	OIL PUMP	Inspect	4.0						E
		Replace		2.5				1	
01010101030102	HOSES & FITTINGS	Inspect	0.2						E
		Replace		2.0				1	
01010101030103	OIL COOLER	Inspect	0.2						E
010101010302	GEAR SHAFT	Inspect				5.0		7	E
		Replace		3.5				1	
		Repair				8.0		3, 7, 17	
		Replace				7.0		3, 7, 17, 19	
01010101030201	UPPER SHAFT	Inspect				5.0		7	X E
		Repair				8.0		3, 7, 17	
		Replace				7.0		3, 7, 17, 19	

Table 1. MAC for Modular Causeway System. (MCS) (Continued)

(1) GROUP NO.	(2) COMPONENT/ASSEMBLY	(3) MAINTENANCE FUNCTION	(4) MAINTENANCE LEVEL					(5) TOOLS AND EQUIP REF CODE	(6) REMARKS CODE
			UNIT		DS	GS	DEPOT		
			C	O	F	H	D		
0101010103020101	INPUT SEAL	Clean			2.0			7	E
		Inspect			2.0			7	E
		Replace			2.0			3, 7, 17, 19	
0101010103020102	OUTPUT SEAL	Clean			2.0			7	E
		Inspect			2.0			7	E
		Replace			2.0			3, 7, 17, 19	
01010101030202	INTERMEDIATE SHAFT	Inspect				2.5		7	E
		Repair				5.5		3, 7, 17	
		Replace				6.5		3, 7, 17, 19	
01010101030203	LOWER SHAFT	Inspect				4.0		7	E
		Repair				8.0		3, 7, 17	
		Replace				6.0		3, 7, 17, 19	
0101010103020301	INPUT SEAL	Clean			2.0			7	E
		Replace			2.0			3, 7, 17, 19	
		Inspect			2.0			7	E

Table 1. MAC for Modular Causeway System. (MCS) (Continued)

(1) GROUP NO.	(2) COMPONENT/ASSEMBLY	(3) MAINTENANCE FUNCTION	(4) MAINTENANCE LEVEL					(5) TOOLS AND EQUIP REF CODE	(6) REMARKS CODE
			UNIT		DS	GS	DEPOT		
			C	O	F	H	D		
00	MODULAR CAUSEWAY SYSTEM (MCS)								
01	CAUSEWAY FERRY (CF)								
02	ROLL-ON/ROLL- OFF DISCHARGE FACILITY (RRDF)								
0201	INTERMEDIATE SECTION								
020101	NON-POWERED MODULE								
02010101	HULL								
0201010101	EXTERIOR	Clean		4.0				8, 9, 23, 24	E
		Inspect	1.0						E
		Repair		4.0				1, 16	
		Service	1.5						E
		Overhaul					24.0		
		Inspect					2.0		
0201010102	INTERIOR	Clean					4.0		
		Test		6.0			5.0	1, 25, 26	E
		Repair					6.0		
02010102	GUILLOTINE FITTINGS	Clean		1.0				8, 9, 23, 24	E
		Overhaul					50.0		
		Inspect	0.5						E
		Repair		3.0				1, 16	
		Replace		1.0				1	

Table 1. MAC for Modular Causeway System. (MCS) (Continued)

(1) GROUP NO.	(2) COMPONENT/ASSEMBLY	(3) MAINTENANCE FUNCTION	(4) MAINTENANCE LEVEL					(5) TOOLS AND EQUIP REF CODE	(6) REMARKS CODE
			UNIT		DS	GS	DEPOT		
			C	O	F	H	D		
02010103	FLEXORS	Inspect	0.5						E
		Replace	4.0						
0202	COMBINATION BEACH-END SECTION								
020201	NON-POWERED MODULE								
02020101	HULL								
0202010101	EXTERIOR	Clean		4.0				8, 9, 23, 24	E
		Inspect	1.0						E
		Service	1.5						E
		Repair		4.0				1, 16	
		Overhaul					24.0		
		Inspect					2.0		
0202010102	INTERIOR	Clean					4.0		
		Test		6.0			5.0	1, 25, 26	E
		Repair					6.0		
		Overhaul					50.0		
02020102	GUILLOTINE FITTINGS	Clean		1.0				8, 9, 23, 24	E
		Inspect	0.5						E
		Repair		3.0				1, 16	
		Replace		1.0				1	
02020103	FLEXORS	Inspect	0.5						E
		Replace	4.0						
0203	GENERATOR SHELTER			4.0				1	

Table 1. MAC for Modular Causeway System. (MCS) (Continued)

(1) GROUP NO.	(2) COMPONENT/ASSEMBLY	(3) MAINTENANCE FUNCTION	(4) MAINTENANCE LEVEL					(5) TOOLS AND EQUIP REF CODE	(6) REMARKS CODE
			UNIT		DS	GS	DEPOT		
			C	O	F	H	D		
020301	ARMY TACTICAL QUIET GENERATOR (ATQG)								AD
020302	FUEL SYSTEM	Inspect	1.0						E
		Repair			1.5			7	
		Replace		1.0				1	
02030201	MANUAL FUEL PUMP	Clean		1.0				1	E
		Inspect	1.0	1.0				1	E
		Repair		2.0				1	
		Replace		2.0				1	
020303	LOUVERS	Clean		1.0				1	E
		Inspect	1.0						E
		Service		1.0				1	E
		Repair		3.0				1	
		Replace		4.0				1	
020304	ELECTRICAL SYSTEM	Test			2.0			7, 14, 15	E
		Repair		2.0	3.0			1, 7, 14, 15	
		Replace			5.0			7, 14, 15	
020305	FIRE SUPPRESSION SYSTEM	Test					4.0		E, G
		Inspect	1.0						E
		Repair					4.0	1, 14, 15	G
		Replace					40.0		G
0204	PERSONNEL SHELTER								

Table 1. MAC for Modular Causeway System. (MCS) (Continued)

(1) GROUP NO.	(2) COMPONENT/ASSEMBLY	(3) MAINTENANCE FUNCTION	(4) MAINTENANCE LEVEL					(5) TOOLS AND EQUIP REF CODE	(6) REMARKS CODE
			UNIT		DS	GS	DEPOT		
			C	O	F	H	D		
020401	HEAT PUMP	Clean		4.0				1	E
		Inspect		1.0				1	E
		Service			3.0			7, 21	E
		Repair		2.0	4.0			1, 7, 14, 15, 21	
		Replace			8.0			7, 14, 15, 21	
		Rebuild				8.0		7, 14, 15, 21	
020402	INCINOLET							AE	
020403	ELECTRICAL SYSTEM	Inspect	2.0						E
		Repair		12.0	3.0			1, 7, 14, 15	
		Replace			12.0			7, 14, 15	
020404	COMMUNICATIONS EQUIPMENT								
02040401	VHF\FM HANDHELD TRANSCEIVER	Replace	1.0						
		Repair				8.0			
0205	LIGHT TOWER								
020501	ELECTRICAL SYSTEM	Inspect			0.5			10, 15	E
		Test			1.0			10, 15	E
02050101	BATTERIES	Repair			6.0			10, 15	
		Test			1.0			10, 13	E
		Inspect	0.5						E
		Replace		2.0			1		

Table 1. MAC for Modular Causeway System. (MCS) (Continued)

(1) GROUP NO.	(2) COMPONENT/ASSEMBLY	(3) MAINTENANCE FUNCTION	(4) MAINTENANCE LEVEL					(5) TOOLS AND EQUIP REF CODE	(6) REMARKS CODE
			UNIT		DS	GS	DEPOT		
			C	O	F	H	D		
02050102	OIL PRESSURE UNIT	Test			1.0			10	E
		Repair			1.0			10	
		Replace			1.5			10	
02050103	STARTING CIRCUIT	Repair			2.0			10, 15	
		Replace			3.0			10, 15	
02050104	ENGINE TEMPERATURE UNIT	Test			1.0			10, 18	E
		Replace			2.5			10, 18	
		Repair			2.0			10, 18	
02050105	HOURMETER UNIT	Repair			1.5			10	
		Replace			2.0			10	
02050106	SHUTDOWN CIRCUIT	Repair			2.0			10	
		Replace			4.0			10	
02050107	LAMP SYSTEM	Test	1.0						E
		Repair			2.0			10, 15	
		Replace			6.0			10, 15	
02050108	LAMP BALLAST SYSTEM	Test			0.5			10, 15	E
		Repair			2.0			10, 15	
		Replace			3.0			10, 15	
020502	GENERATOR	Clean		2.0				1	E
		Inspect					12.0		
		Repair					18.0		
		Replace					24.0		

Table 1. MAC for Modular Causeway System. (MCS) (Continued)

(1) GROUP NO.	(2) COMPONENT/ASSEMBLY	(3) MAINTENANCE FUNCTION	(4) MAINTENANCE LEVEL					(5) TOOLS AND EQUIP REF CODE	(6) REMARKS CODE
			UNIT		DS	GS	DEPOT		
			C	O	F	H	D		
02050202	CONTROL PANEL	Inspect	1.0						E
		Repair			3.0			10, 15	
		Replace			4.5			10, 15	
02050205	DIESEL ENGINE	Service	4.0	2.0				1	E
		Adjust		3.0				1	
		Overhaul					16.0		
		Repair				16.0		10	
		Replace			16.0			10	
0205020501	ENGINE FUEL SYSTEM	Inspect	1.0						E
		Repair		4.0				1	
		Replace			8.0			10	
020502050101	FUEL PUMP	Inspect	1.0						E
		Repair				4.0		10	
		Replace			5.0			10	
020502050102	FUEL TANK	Clean	2.0						E
		Inspect	1.0						E
		Repair		2.0				1	
		Replace		2.0				1	
0205020502	ENGINE AIR SYSTEM	Inspect	1.0						E
		Repair		2.0				1	
		Replace		4.0				1	
0205020503	ENGINE COOLING SYSTEM	Inspect	1.0						E
		Repair		3.0				1	
		Replace		2.0		5.0		1, 10	

Table 1. MAC for Modular Causeway System. (MCS) (Continued)

(1) GROUP NO.	(2) COMPONENT/ASSEMBLY	(3) MAINTENANCE FUNCTION	(4) MAINTENANCE LEVEL					(5) TOOLS AND EQUIP REF CODE	(6) REMARKS CODE
			UNIT		DS	GS	DEPOT		
			C	O	F	H	D		
020502050301	FAN ASSEMBLY	Inspect	0.5						E
		Repair		1.5				1	
		Replace		2.0				1	
020502050302	COOLING WATER PUMP	Inspect			1.0			10	E
		Repair				4.0		10	
		Replace			5.0			10	
020502050303	RADIATOR	Clean	1.0						E
		Inspect		1.0				1	E
		Service	2.0	4.0				1	E
		Repair				4.0		10	
		Replace		2.0	3.0			1, 10	
0205020504	CYLINDER HEAD	Inspect		1.0				1	E
		Adjust					2.0		
		Repair					8.0		
		Replace					5.0		
0205020505	VIBRATION DAMPER	Repair					4.0		
		Replace					4.0		
0205020506	EXHAUST SYSTEM	Clean	1.5						E
		Inspect	1.0						E
		Repair		3.0				1, 16	
		Replace		5.0				1	
0205020507	CRANKSHAFT	Inspect					4.0		
		Repair					8.0		
		Replace					8.0		

Table 1. MAC for Modular Causeway System. (MCS) (Continued)

(1) GROUP NO.	(2) COMPONENT/ASSEMBLY	(3) MAINTENANCE FUNCTION	(4) MAINTENANCE LEVEL					(5) TOOLS AND EQUIP REF CODE	(6) REMARKS CODE
			UNIT		DS	GS	DEPOT		
			C	O	F	H	D		
0205020508	PISTON	Inspect					4.0		
		Repair					4.0		
		Replace					4.0		
02050206	RUNNING GEAR	Service		2.0				1	E
		Repair		2.0		2.0		1, 10	
		Replace		18.0				1	
0205020601	TIRES	Inspect	0.5						E
		Repair				1.0		10	
		Replace				1.0		10	
02050207	SUPPORT TOWER	Inspect	0.5						E
		Service	1.0						E
		Repair			2.0			10	
		Replace			6.0			10	
02050208	TOWER RAISING ASSEMBLY	Inspect	0.5						E
		Repair			1.0			10	
		Replace			3.0			10	
02050209	ENCLOSURE	Inspect	0.5						E
		Repair			2.0			10	
		Replace			6.0			10	
0206	EASY ANCHOR	Inspect	2.0						E
		Service		1.0				1	E
		Repair			4.0			6, 7	
		Replace			6.0			6, 7	
0207	RHIB (ZODIAC)								

Table 1. MAC for Modular Causeway System. (MCS) (Continued)

(1) GROUP NO.	(2) COMPONENT/ASSEMBLY	(3) MAINTENANCE FUNCTION	(4) MAINTENANCE LEVEL					(5) TOOLS AND EQUIP REF CODE	(6) REMARKS CODE
			UNIT		DS	GS	DEPOT		
			C	O	F	H	D		
020701	STEERING & THROTTLE	Inspect	1.0						E
		Service	1.0						E
		Repair			4.0			10	
		Replace			8.0			10	
020702	CONTROL PANEL	Inspect			2.0			10, 15	E
		Repair			4.0			10, 15	
		Replace			6.0			10, 15	
020703	BOAT HULL	Inspect	1.0						E
		Repair		2.0		20.0		1, 219-230	
		Replace				18.0		1, 219-230	
020704	NAVIGATION SYSTEM	Repair			3.0		12.0	7	
		Replace		2.0				1	
020705	OUTBOARD ENGINE	Test		4.0					E
		Repair					12.0		
		Rebuild					12.0		
		Replace		4.0					
02070501	ENGINE COVER	Inspect	1.0						E
		Repair			2.0			10	
		Replace			2.0			10	
02070502	LOWER ENGINE COVER	Inspect	1.0						E
		Repair			2.0			10	
		Replace			2.0			10	

Table 1. MAC for Modular Causeway System. (MCS) (Continued)

(1) GROUP NO.	(2) COMPONENT/ASSEMBLY	(3) MAINTENANCE FUNCTION	(4) MAINTENANCE LEVEL					(5) TOOLS AND EQUIP REF CODE	(6) REMARKS CODE
			UNIT		DS	GS	DEPOT		
			C	O	F	H	D		
02070503	ELECTRICAL STARTER	Repair			2.0			10, 15	
		Replace			3.0			10, 15	
02070504	POWER TRIM/TILT ELECTRICAL	Adjust		1.0				1	
		Repair			2.0			10, 15	
		Replace			2.5			10, 15	
02070505	IGNITION	Repair					8.0		
		Replace					8.0	2, 17	
02070506	INTAKE MANIFOLD	Inspect			1.0			10	E
		Repair			3.0			10	
		Replace			3.0			10	
02070507	CARBURETOR	Adjust		1.0				1	
		Repair			3.0			10	
		Replace			3.0			10	
02070508	ELECTRIC PRIMER SYSTEM	Repair			3.0			10, 15	
		Replace			2.0			10, 15	
02070509	FUEL TANK	Inspect	1.0						E
		Repair			3.0			10	
		Replace	2.0						
02070510	FUEL HOSE & PRIMER BULB	Repair		1.0				1	
		Replace	1.0						
02070511	FUEL PUMP	Repair			2.0			10	
		Replace			2.0			10	

Table 1. MAC for Modular Causeway System. (MCS) (Continued)

(1) GROUP NO.	(2) COMPONENT/ASSEMBLY	(3) MAINTENANCE FUNCTION	(4) MAINTENANCE LEVEL					(5) TOOLS AND EQUIP REF CODE	(6) REMARKS CODE
			UNIT		DS	GS	DEPOT		
			C	O	F	H	D		
02070512	CRANKSHAFT & PISTON	Inspect					6.0		
		Repair					8.0		
		Replace					8.0		
02070513	CYLINDER & CRANKCASE	Inspect					6.0		
		Rebuild					16.0		
		Replace					8.0		
02070514	EXHAUST HOUSING	Inspect	1.0						E
		Repair			3.0			10	
		Replace			3.0			10	
02070515	POWER TRIM/TILT HYDRAULIC	Repair					4.0		
		Replace					3.0		
02070516	POWER TRIM/TILT MIDSECTION	Inspect					2.0		
		Repair					4.0		
		Replace					4.0		
02070517	GEARCASE	Inspect			3.0			10	E
		Repair					8.0		
		Replace					8.0		
0207051701	BEARING HOUSING ASSEMBLY	Inspect					2.0		
		Repair					3.0		
		Replace					3.0		

Table 1. MAC for Modular Causeway System. (MCS) (Continued)

(1) GROUP NO.	(2) COMPONENT/ASSEMBLY	(3) MAINTENANCE FUNCTION	(4) MAINTENANCE LEVEL					(5) TOOLS AND EQUIP REF CODE	(6) REMARKS CODE
			UNIT		DS	GS	DEPOT		
			C	O	F	H	D		
0207051702	PROPELLER SHAFT ASSEMBLY	Inspect					2.0		
		Repair					4.0		
		Replace					3.0		
0207051703	IMPELLER ASSEMBLY	Inspect					4.0		
		Repair					4.0		
		Replace					4.0		
0207051704	WATER PUMP ASSEMBLY	Inspect					4.0		
		Repair					4.0		
		Rebuild					8.0		
		Replace					4.0		
02070518	STEERING LINK KIT	Inspect	1.0						E
		Repair		1.0				1	
		Replace		2.0				1	
02070519	BATTERY	Test			2.0			10, 13	
		Service			2.0			10	
		Replace			2.0			10	
0207051901	BATTERY CABLE	Clean	0.5						
		Inspect	0.5						E
		Repair		1.0				1	
		Replace		1.0				1	
020706	FIRE EXTINGUISHER	Inspect	0.5						E
		Replace	2.0						E

Table 1. MAC for Modular Causeway System. (MCS) (Continued)

(1) GROUP NO.	(2) COMPONENT/ASSEMBLY	(3) MAINTENANCE FUNCTION	(4) MAINTENANCE LEVEL					(5) TOOLS AND EQUIP REF CODE	(6) REMARKS CODE
			UNIT		DS	GS	DEPOT		
			C	O	F	H	D		
0208	CONTAINERS	Inspect	2.0						E
		Clean	1.0						E
		Repair			4.0			7	
		Replace					8.0		

Table 1. MAC for Modular Causeway System. (MCS) (Continued)

(1) GROUP NO.	(2) COMPONENT/ASSEMBLY	(3) MAINTENANCE FUNCTION	(4) MAINTENANCE LEVEL					(5) TOOLS AND EQUIP REF CODE	(6) REMARKS CODE
			UNIT		DS	GS	DEPOT		
			C	O	F	H	D		

Table 1. MAC for Modular Causeway System. (MCS) (Continued)

(1) GROUP NO.	(2) COMPONENT/ASSEMBLY	(3) MAINTENANCE FUNCTION	(4) MAINTENANCE LEVEL					(5) TOOLS AND EQUIP REF CODE	(6) REMARKS CODE
			UNIT		DS	GS	DEPOT		
			C	O	F	H	D		
00	MODULAR CAUSEWAY SYSTEM (MCS)								
01	CAUSEWAY FERRY (CF)								
02	ROLL-ON/ROLL-OFF DISCHARGE FACILITY (RRDF)								
03	MODULAR WARPING TUG (WT)								
0301	POWERED SECTION								
030101	POWERED MODULE								
03010101	DRIVE TRAIN								
0301010101	DIESEL ENGINE								Z
0301010102	MARINE GEAR								AA
0301010103	TRANSFER CASE								AB
0301010104	PUMP-JET ASSEMBLY	Inspect	0.5						E
		Service		3.0				1	E
		Repair					10.0		D
		Replace					50.0		
030101010401	HYDRAULIC SYSTEM	Inspect	1.0					1	E
		Service	1.0	3.0				1	E
		Repair			3.0			2, 4, 7	
		Replace			6.0			2, 4, 7	

Table 1. MAC for Modular Causeway System. (MCS) (Continued)

(1) GROUP NO.	(2) COMPONENT/ASSEMBLY	(3) MAINTENANCE FUNCTION	(4) MAINTENANCE LEVEL					(5) TOOLS AND EQUIP REF CODE	(6) REMARKS CODE
			UNIT		DS	GS	DEPOT		
			C	O	F	H	D		
03010101040101	HYDRAULIC PUMP	Test	0.5						E
		Inspect	1.0						E
		Repair				4.0		2, 4, 7	
		Replace		6.0				1, 2, 4	
03010101040102	HYDRAULIC HAND PUMP	Inspect	1.0						E
		Repair					20.0		
		Replace		2.0				1, 2, 4	
03010101040103	HYDRAULIC WAY-VALVE	Repair				2.0		2, 4, 7	
		Replace		1.5				1, 2, 4	
030101010402	FEEDBACK UNIT	Inspect	1.0						E
		Repair				2.5		2, 4, 7	
		Replace			2.0			2, 4, 7	
0301010105	ALTERNATOR	Test			1.0			7, 14, 15	E
		Inspect	0.5						E
		Replace			2.0			7, 14, 15	
03010102	ENGINE EXHAUST SYSTEM	Clean		2.0				1, 3, 9	E
		Inspect		2.0				1, 3, 9	E
		Repair			6.0			3, 7, 9	
03010103	BILGE PUMP SYSTEM	Test		2.0				1	E
		Inspect	1.0						E
03010104	FIRE SUPPRESSION SYSTEM	Test					3.0		E
		Inspect	2.0				3.0		E

Table 1. MAC for Modular Causeway System. (MCS) (Continued)

(1) GROUP NO.	(2) COMPONENT/ASSEMBLY	(3) MAINTENANCE FUNCTION	(4) MAINTENANCE LEVEL				(5) TOOLS AND EQUIP REF CODE	(6) REMARKS CODE	
			UNIT		DS	GS			DEPOT
			C	O	F	H			D
03010104	FIRE SUPPRESSION SYSTEM (CONT'D)	Repair					8.0	G	
		Replace					24.0	G	
03010105	FUEL SYSTEM	Test	1.0					E	
		Inspect	1.0					E	
		Repair			4.0			7	
		Replace			12.0			7	
0301010501	FUEL/WATER SEPARATOR	Clean	1.0					E	
		Inspect	1.0					E	
		Repair		2.0				1	
		Replace			4.0			7	
03010106	ELECTRICAL SYSTEM	Test			1.0			7, 14, 15	E
		Adjust			1.0			7, 14, 15	
		Repair			2.0			7, 14, 15	
		Replace			8.0			7, 14, 15	
03010107	EMERGENCY STEERING SYSTEM	Inspect	2.0					E	
		Service	1.0					E	
		Replace		4.0				1	
0301010701	STEERING UNIT	Inspect	0.5					E	
		Replace		2.0				1	
0301010702	STEERING ADAPTOR	Inspect	0.5					E	
		Replace		1.5				1	
03010108	HULL								

Table 1. MAC for Modular Causeway System. (MCS) (Continued)

(1) GROUP NO.	(2) COMPONENT/ASSEMBLY	(3) MAINTENANCE FUNCTION	(4) MAINTENANCE LEVEL				(5) TOOLS AND EQUIP REF CODE	(6) REMARKS CODE	
			UNIT		DS	GS			DEPOT
			C	O	F	H			D
0301010801	EXTERIOR	Clean		4.0				8, 9, 23, 24	E
		Inspect	1.0						E
		Service	1.5						E
		Repair		4.0				1, 16	
		Overhaul					24.0		
0301010802	INTERIOR	Clean					4.0		
		Inspect					2.0		
		Test					5.0	1, 25, 26	E
		Repair					6.0		
		Overhaul					50.0		
03010109	GUILLOTINE FITTINGS	Clean		1.0				8, 9, 23, 24	E
		Inspect	0.5						E
		Repair		3.0				1, 16	
		Replace		1.0				1	
03010110	HATCHES & HINGES	Clean	1.0						E
		Inspect	0.5					1	E
		Service	0.5						E
		Repair		2.0				1, 16	
		Replace		2.0				1	
03010111	FLEXORS	Inspect	0.5						E
		Replace	4.0						
030102	NON-POWERED MODULE								
03010201	HULL								

Table 1. MAC for Modular Causeway System. (MCS) (Continued)

(1) GROUP NO.	(2) COMPONENT/ASSEMBLY	(3) MAINTENANCE FUNCTION	(4) MAINTENANCE LEVEL					(5) TOOLS AND EQUIP REF CODE	(6) REMARKS CODE
			UNIT		DS	GS	DEPOT		
			C	O	F	H	D		
0301020101	EXTERIOR	Clean		4.0				8, 9, 23, 24	E
		Inspect	1.0						E
		Service	1.5						E
		Repair		4.0				1, 16	
		Overhaul					24.0		
0301020102	INTERIOR	Clean					4.0		
		Inspect					2.0		
		Test		8.0			5.0	1, 25, 26	E
		Repair					6.0		
		Overhaul					50.0		
03010202	GUILLOTINE FITTINGS	Clean		1.0				8, 9, 23, 24	E
		Inspect	0.5						E
		Repair		3.0				1, 16	
		Replace	1.0					1	
030103	OPERATORS CAB								
03010301	MIDDLE CONTROL PANEL	Test			2.0			7, 14, 15	E
		Inspect			2.0			7, 14, 15	E
		Repair			3.0			7, 14, 15	
		Replace			16.0			7, 14, 15	
03010302	LOWER CONTROL PANEL	Test			2.0			7, 14, 15	E
		Inspect			2.0			7, 14, 15	E
		Repair			3.0			7, 14, 15	
		Replace			16.0			7, 14, 15	

Table 1. MAC for Modular Causeway System. (MCS) (Continued)

(1) GROUP NO.	(2) COMPONENT/ASSEMBLY	(3) MAINTENANCE FUNCTION	(4) MAINTENANCE LEVEL					(5) TOOLS AND EQUIP REF CODE	(6) REMARKS CODE
			UNIT		DS	GS	DEPOT		
			C	O	F	H	D		
03010303	CIRCUIT BREAKER PANEL	Test			1.0			7, 14, 15	E
		Inspect			1.0			7, 14, 15	E
		Repair			2.0			7, 14, 15	
		Replace			12.0			7, 14, 15	
03010304	TERMINAL BOARD A-4	Test			1.0			7, 14, 15	E
		Inspect			1.0			7, 14, 15	E
		Repair			2.0			7, 14, 15	
		Replace			10.0			7, 14, 15	
03010305	SPOTLIGHT	Adjust		1.0				1	
		Replace		1.0				1	
03010306	DEFROSTER	Inspect	1.0						E
		Replace			4.0			7, 14, 15	
03010307	HEATER	Inspect		2.0				1	E
		Repair			4.0			7, 14, 15	
		Replace			6.0			7, 14, 15	
03010308	WINDSHIELD WIPER	Repair		1.0				1	
		Replace		2.0				1	
03010309	COMMUNICATIONS EQUIPMENT								
0301030901	VHF/FM HANDHELD TRANSCEIVER	Repair					8.0		
		Replace		1.0				1	

Table 1. MAC for Modular Causeway System. (MCS) (Continued)

(1) GROUP NO.	(2) COMPONENT/ASSEMBLY	(3) MAINTENANCE FUNCTION	(4) MAINTENANCE LEVEL				(5) TOOLS AND EQUIP REF CODE	(6) REMARKS CODE	
			UNIT		DS	GS			DEPOT
			C	O	F	H			D
0301030902	AN/PSN-11 INTERFACE & SWITCHBOX	Repair					6.0		
		Replace			1.0			7, 14, 15	
0301030903	LOUDHAILER	Test	0.5						
		Repair					8.0		
		Replace	0.5						
0301030904	SINGARS RADIO							H	
0301030905	VHF/FM DSC TRANSCEIVER	Repair					12.0		
		Replace		1.0				1	
03010310	NAVIGATION EQUIPMENT	Test	0.5					E	
		Inspect	1.0						E
0301031001	COMPASS	Inspect	2.0					E	
		Replace		2.0				1	
		Calibrate		4.0				1	
0301031002	PLGR							I	
03010311	MAST	Inspect	3.0					E	
		Repair		3.0				1	
0301031101	NAVIGATION LIGHTS	Repair		1.0				1	
		Replace		1.0				1	
03010312	OPERATORS CAB ELECTRICAL SYSTEM	Test			4.0			7, 14, 15	E
		Inspect			4.0			7, 14, 15	E
		Repair				6.0		7, 14, 15	
		Replace			10.0			7, 14, 15	

Table 1. MAC for Modular Causeway System. (MCS) (Continued)

(1) GROUP NO.	(2) COMPONENT/ASSEMBLY	(3) MAINTENANCE FUNCTION	(4) MAINTENANCE LEVEL					(5) TOOLS AND EQUIP REF CODE	(6) REMARKS CODE
			UNIT		DS	GS	DEPOT		
			C	O	F	H	D		
030104	ANCHOR ASSEMBLY	Inspect	1.0						E
		Repair		1.0				1	
		Replace		1.0				1	
0302	CONTAINERS	Clean	1.0						E
		Inspect	2.0						E
		Repair			4.0			7	
		Replace					8.0		
0303	WINCH								AC
030301	WINCH DIESEL ENGINE								AD
030302	WINCH ASSEMBLY	Clean			8.0			7	E
		Test			4.0			7	E
		Inspect			4.0			7	E
		Service	4.0						
		Repair			4.0			7	
		Replace	3.0						

Table 1. MAC for Modular Causeway System. (MCS) (Continued)

(1) GROUP NO.	(2) COMPONENT/ASSEMBLY	(3) MAINTENANCE FUNCTION	(4) MAINTENANCE LEVEL					(5) TOOLS AND EQUIP REF CODE	(6) REMARKS CODE
			UNIT		DS	GS	DEPOT		
			C	O	F	H	D		
00	MODULAR CAUSEWAY SYSTEM (MCS)								
01	CAUSEWAY FERRY (CF)								
02	ROLL-ON/ROLL-OFF DISCHARGE FACILITY (RRDF)								
03	MODULAR WARPING TUG (WT)								
0301010101	DIESEL ENGINE	Inspect	4.0						E
		Service	4.0	4.0					E
		Repair				30.0		7, 27-218	
		Replace			120.0			7, 27-218	
		Overhaul					80.0		
030101010101	ENGINE BLOCK ASSEMBLY	Inspect	2.0						E, J
		Repair				6.0		7, 27-52	J
		Replace				120.0		7, 27-52	J
030101010102	CYLINDER HEAD ASSEMBLY	Clean				5.0		7, 53-85	K
		Inspect			6.0			7, 53-85	K
		Repair				12.0		7, 53-85	K
		Replace			8.0			7, 53-85	K
030101010103	CRANKSHAFT ASSEMBLY	Repair			16.0			7, 86-106	L
		Replace			24.0			7, 86-106	L
030101010104	CAMSHAFT ASSEMBLY	Repair				12.0		7, 131-141	
		Replace				16.0		7, 131-141	

Table 1. MAC for Modular Causeway System. (MCS) (Continued)

(1) GROUP NO.	(2) COMPONENT/ASSEMBLY	(3) MAINTENANCE FUNCTION	(4) MAINTENANCE LEVEL					(5) TOOLS AND EQUIP REF CODE	(6) REMARKS CODE
			UNIT		DS	GS	DEPOT		
			C	O	F	H	D		
030101010105	FLYWHEEL ASSEMBLY	Inspect			3.0			7, 107-112	M
		Repair				3.0		7, 107-112	M
		Replace			5.0			7, 107-112	M
030101010106	PISTON ASSEMBLY	Clean				2.0		7, 113-130	N
		Inspect				2.0		7, 113-130	N
		Rebuild				4.5		7, 113-130	N
		Replace				3.0		7, 113-130	N
030101010107	ENGINE BALANCE	Inspect				6.0		7, 131-141	O
		Adjust				3.0		7, 131-141	O
		Repair				8.0		7, 131-141	O
		Replace				8.0		7, 131-141	O
030101010108	FUEL SYSTEM	Inspect	0.5					E, P	
03010101010801	FUEL PUMP	Inspect			1.0			7, 142-187	E
		Repair			4.0			7, 142-187	
		Replace			2.0			7, 142-187	
03010101010802	PRIMING PUMP	Inspect		1.5				1, 142-187	E
		Replace		2.0				1, 142-187	
030101010109	ELECTRIC GOVERNOR	Test		0.5					E
		Adjust			1.0			7, 142-187	
		Repair					5.0		
		Replace		2.0				1, 142-187	
030101010110	AIR INTAKE SYSTEM	Clean		2.0				1, 188-195	E, Q
		Inspect	0.5						E, Q
		Replace		3.0				1, 188-195	Q

Table 1. MAC for Modular Causeway System. (MCS) (Continued)

(1) GROUP NO.	(2) COMPONENT/ASSEMBLY	(3) MAINTENANCE FUNCTION	(4) MAINTENANCE LEVEL					(5) TOOLS AND EQUIP REF CODE	(6) REMARKS CODE
			UNIT		DS	GS	DEPOT		
			C	O	F	H	D		
03010101011001	BLOWER	Inspect			2.0	2.0		7, 188-195	E
		Adjust				4.0		7, 188-195	
		Repair				18.0		7, 188-195	
		Replace			8.0			7, 188-195	
03010101011002	TURBOCHARGER	Inspect			2.0			1, 188-195	E, R
		Repair					18.0		
		Replace			6.0			7, 188-195	
030101010111	LUBE OIL SYSTEM	Service	5.0	5.0					E, S
		Inspect	1.0						E, S
03010101011101	LUBE OIL PUMP	Inspect				3.0		7, 196-203	E
		Repair				4.0		7, 196-203	
		Replace				4.0		7, 196-203	
03010101011102	LUBE OIL COOLER	Clean			2.0			7	E
		Test			1.5			7, 25, 26	E
		Inspect			2.0			7	E
		Repair			4.0			7	
		Replace			2.0			7	
030101010112	FRESH WATER COOLING SYSTEM	Inspect	1.0						E, T
		Clean		1.0				1	
03010101011201	FRESH WATER PUMP	Inspect			2.5			7, 212-215	E
		Repair			6.0			7, 212-215	
		Replace			3.0			7, 212-215	

Table 1. MAC for Modular Causeway System. (MCS) (Continued)

(1) GROUP NO.	(2) COMPONENT/ASSEMBLY	(3) MAINTENANCE FUNCTION	(4) MAINTENANCE LEVEL					(5) TOOLS AND EQUIP REF CODE	(6) REMARKS CODE
			UNIT		DS	GS	DEPOT		
			C	O	F	H	D		
03010101011202	FRESH WATER COOLER	Clean			2.0			7	E
		Test			2.0			7, 25, 26	E
		Inspect			1.0			7	E
		Repair			4.0			7	
		Replace			3.0			7	
030101010113	RAW WATER COOLING SYSTEM	Clean	1.0						E, U
		Inspect		2.0				1	E, U
03010101011301	RAW WATER PUMP	Inspect		2.0				1	E
		Repair			4.0			7, 212-215	
		Replace		2.5				1, 211-215	
030101010114	ELECTRICAL SYSTEM	Test			4.0			7, 14, 15	E, V
		Inspect			2.0			7, 14, 15	E, V
		Repair			3.0			7, 14, 15	V
		Replace		4.0	16.0			1, 7, 14, 15	V
03010101011401	STARTER	Inspect	1.0						E
		Repair				6.0		7, 14, 15	
		Replace		3.0				1, 14, 15	
03010101011402	COLD PACK STARTER	Clean		1.0				1	E
		Inspect	0.5						E
		Adjust		1.0				1, 14, 15	
		Repair		2.5				1, 14, 15	
		Replace		3.0				1, 14, 15	

Table 1. MAC for Modular Causeway System. (MCS) (Continued)

(1) GROUP NO.	(2) COMPONENT/ASSEMBLY	(3) MAINTENANCE FUNCTION	(4) MAINTENANCE LEVEL					(5) TOOLS AND EQUIP REF CODE	(6) REMARKS CODE
			UNIT		DS	GS	DEPOT		
			C	O	F	H	D		
030101010115	OVER SPEED GOVERNOR	Test				1.0		7	E
		Adjust				1.5		7, 184-187	
		Repair				5.0		7, 184-187	
		Replace				4.0		7, 184-187	
030101010116	AUTO SHUTDOWN SYSTEM	Test		1.0					E
		Adjust			2.0			7, 14, 15	
		Repair				6.0		7, 14, 15	
		Replace		4.0			8.0	1	

Table 1. MAC for Modular Causeway System. (MCS) (Continued)

(1) GROUP NO.	(2) COMPONENT/ASSEMBLY	(3) MAINTENANCE FUNCTION	(4) MAINTENANCE LEVEL					(5) TOOLS AND EQUIP REF CODE	(6) REMARKS CODE
			UNIT		DS	GS	DEPOT		
			C	O	F	H	D		

Table 1. MAC for Modular Causeway System. (MCS) (Continued)

(1) GROUP NO.	(2) COMPONENT/ASSEMBLY	(3) MAINTENANCE FUNCTION	(4) MAINTENANCE LEVEL					(5) TOOLS AND EQUIP REF CODE	(6) REMARKS CODE
			UNIT		DS	GS	DEPOT		
			C	O	F	H	D		
00	MODULAR CAUSEWAY SYSTEM (MCS)								
01	CAUSEWAY FERRY (CF)								
02	ROLL-ON/ROLL-OFF DISCHARGE FACILITY (RRDF)								
03	MODULAR WARPING TUG (WT)								
0301010102	MARINE GEAR	Inspect	1.0					E	
		Align			2.0		7, 17		
		Service	1.0	4.0			1	E	
		Replace			28.0		4, 7, 17		
		Rebuild				25.0		W	
030101010201	OIL SYSTEM	Inspect	0.5					E, X	
		Repair		0.5			1, 11	X	
03010101020101	OIL COOLER	Clean	1.0					E	
		Inspect	1.0					E	
		Replace		4.0			1		
03010101020102	LINES & HOSES	Inspect	0.2					E	
		Repair		0.5			1		
		Replace		2.0			1		
03010101020103	OIL PUMP	Inspect	1.0					E	
		Replace			2.0		1, 3		
03010101020104	ELECTRIC CONTROL VALVE	Repair				8.0			
		Replace			6.0		7, 14, 15		

Table 1. MAC for Modular Causeway System. (MCS) (Continued)

(1) GROUP NO.	(2) COMPONENT/ASSEMBLY	(3) MAINTENANCE FUNCTION	(4) MAINTENANCE LEVEL					(5) TOOLS AND EQUIP REF CODE	(6) REMARKS CODE
			UNIT		DS	GS	DEPOT		
			C	O	F	H	D		
030101010202	GEAR MOUNTS	Inspect	0.5						E
		Replace			2.0			3, 7	
030101010203	COUPLING BLOCKS	Clean			1.0			7	E
		Inspect			1.0			7	E
		Replace			4.0			3, 7	
030101010204	OUTPUT FLANGE	Inspect	0.5						E
		Align			2.0			3, 7, 17	
		Replace			4.0			3, 7, 17	
030101010205	OUTPUT SEAL	Inspect			2.0			7	E
		Replace			2.0			3, 7	
030101010206	INPUT FLANGE (ENGINE CONNECTION)	Inspect	0.5						E

Table 1. MAC for Modular Causeway System. (MCS) (Continued)

(1) GROUP NO.	(2) COMPONENT/ASSEMBLY	(3) MAINTENANCE FUNCTION	(4) MAINTENANCE LEVEL					(5) TOOLS AND EQUIP REF CODE	(6) REMARKS CODE
			UNIT		DS	GS	DEPOT		
			C	O	F	H	D		
00	MODULAR CAUSEWAY SYSTEM (MCS)								
01	CAUSEWAY FERRY (CF)								
02	ROLL-ON/ROLL-OFF DISCHARGE FACILITY (RRDF)								
03	MODULAR WARPING TUG (WT)								
0301010103	TRANSFER CASE	Clean		2.0				1	E
		Service	1.0	4.0				1	E
		Overhaul				24.0			
		Rebuild					24.0	2, 7, 17	Y
		Replace			24.0			2, 7, 17	
030101010301	OIL SYSTEM	Inspect	1.0						E
		Repair		2.5				1	
03010101030101	OIL PUMP	Inspect	4.0						E
		Replace		2.5				1	
03010101030102	HOSES & FITTINGS	Inspect	0.2						E
		Replace		2.0				1	
03010101030103	OIL COOLER	Inspect	0.2						E
		Replace		3.5				1	
030101010302	GEAR SHAFT	Inspect				5.0		7	E
		Repair				8.0		3, 7, 17	
		Replace				7.0		3, 7, 17, 19	

Table 1. MAC for Modular Causeway System. (MCS) (Continued)

(1) GROUP NO.	(2) COMPONENT/ASSEMBLY	(3) MAINTENANCE FUNCTION	(4) MAINTENANCE LEVEL					(5) TOOLS AND EQUIP REF CODE	(6) REMARKS CODE
			UNIT		DS	GS	DEPOT		
			C	O	F	H	D		
03010101030201	UPPER SHAFT	Inspect				5.0		7	E
		Repair				8.0		3, 7, 17	
		Replace				7.0		3, 7, 17, 19	
0301010103020101	INPUT SEAL	Clean			2.0			7	E
		Inspect			2.0			7	E
		Replace			2.0			3, 7, 17, 19	
0301010103020102	OUTPUT SEAL	Clean			2.0			7	E
		Inspect			2.0			7	E
		Replace			2.0			3, 7, 17, 19	
03010101030202	INTERMEDIATE SHAFT	Inspect				2.5		7	E
		Repair				5.5		3, 7, 17	
		Replace				6.5		3, 7, 17, 19	
03010101030203	LOWER SHAFT	Inspect				4.0		7	E
		Repair				8.0		3, 7, 17	
		Replace				6.0		3, 7, 17, 19	
0301010103020301	INPUT SEAL	Clean			2.0			7	E
		Inspect			2.0			7	E
		Replace			2.0			3, 7, 17, 19	

Table 1. MAC for Modular Causeway System. (MCS) (Continued)

(1) GROUP NO.	(2) COMPONENT/ASSEMBLY	(3) MAINTENANCE FUNCTION	(4) MAINTENANCE LEVEL					(5) TOOLS AND EQUIP REF CODE	(6) REMARKS CODE
			UNIT		DS	GS	DEPOT		
			C	O	F	H	D		
00	MODULAR CAUSEWAY SYSTEM (MCS)								
01	CAUSEWAY FERRY (CF)								
02	ROLL-ON/ROLL- OFF DISCHARGE FACILITY (RRDF)								
04	FLOATING CAUSEWAY (FC)								
0401	INTERMEDIATE SECTION								
040101	NON-POWERED MODULE								
04010101	HULL								
0401010101	EXTERIOR	Clean		4.0				8, 9, 23, 24	E
		Inspect	1.0						E
		Service	1.5						E
		Repair		4.0				1, 16	
		Overhaul					24.0		
0401010102	INTERIOR	Clean					4.0		
		Inspect					2.0		
		Test		6.0			5.0	1, 25, 26	E
		Repair					6.0		
		Overhaul					50.0		
04010102	GUILLOTINE FITTINGS	Clean		1.0				8, 9, 23, 24	E
		Inspect	0.5						E
		Repair		3.0				1, 16	

Table 1. MAC for Modular Causeway System. (MCS) (Continued)

(1) GROUP NO.	(2) COMPONENT/ASSEMBLY	(3) MAINTENANCE FUNCTION	(4) MAINTENANCE LEVEL				(5) TOOLS AND EQUIP REF CODE	(6) REMARKS CODE	
			UNIT		DS	GS			DEPOT
			C	O	F	H			D
04010102	GUILLOTINE FITTINGS (CONT'D)	Replace		1.0				1	
04010103	FLEXORS	Inspect	0.5						E
		Replace	4.0						
0402	COMBINATION BEACH-END SECTION								
040201	NON-POWERED MODULES								
04020101	HULL								
0402010101	EXTERIOR	Clean		4.0				8, 9, 23, 24	E
		Inspect	1.0						E
		Service	1.5						E
		Repair		4.0				1, 16	
		Overhaul					24.0		
0402010102	INTERIOR	Clean					4.0		
		Inspect					2.0		
		Test					5.0	1, 25, 26	E
		Repair					6.0		
		Overhaul					50.0		
04020102	GUILLOTINE FITTINGS	Clean		1.0				8, 9, 23, 24	E
		Inspect	0.5						E
		Repair		3.0				1, 16	
		Replace		1.0				1	
04020103	FLEXORS	Inspect	0.5						E
		Replace	4.0						

Table 1. MAC for Modular Causeway System. (MCS) (Continued)

(1) GROUP NO.	(2) COMPONENT/ASSEMBLY	(3) MAINTENANCE FUNCTION	(4) MAINTENANCE LEVEL					(5) TOOLS AND EQUIP REF CODE	(6) REMARKS CODE
			UNIT		DS	GS	DEPOT		
			C	O	F	H	D		
0403	GENERATOR SHELTER	Repair		4.0				1	
040301	ARMY TACTICAL QUIET GENERATOR (ATQG)								
040302	FUEL SYSTEM	Clean					1.0		E
		Inspect					1.0	7	
		Repair					5.0	1	
04030201	MANUAL FUEL PUMP	Clean		1.0				1	E
		Inspect	1.0	1.0				1	E
		Repair		2.0				1	
		Replace		2.0				1	
040303	LOUVERS	Clean		1.0				1	E
		Inspect	1.0						E
		Service		1.0					E
		Repair		3.0				1	
		Replace		4.0				1	
040304	ELECTRICAL SYSTEM	Test			2.0			7, 14, 15	E
		Repair		2.0	3.0			1, 7, 14, 15	
		Replace			5.0			7, 14, 15	
040305	FIRE SUPPRESSION SYSTEM	Test					4.0		E, G
		Inspect	1.0						E
		Repair		2.0			4.0	1, 14, 15	G
		Replace					40.0		G

Table 1. MAC for Modular Causeway System. (MCS) (Continued)

(1) GROUP NO.	(2) COMPONENT/ASSEMBLY	(3) MAINTENANCE FUNCTION	(4) MAINTENANCE LEVEL					(5) TOOLS AND EQUIP REF CODE	(6) REMARKS CODE
			UNIT		DS	GS	DEPOT		
			C	O	F	H	D		
0404	PERSONNEL SHELTER								
040401	HEAT PUMP	Clean		4.0				1	E
		Inspect		1.0				1	E
		Service			3.0			7, 21	E
		Repair			4.0			1, 7,14, 15, 21	
		Rebuild				8.0		7,14, 15, 21	
		Replace			8.0			7,14, 15, 21	
040402	INCINOLET								AE
040403	ELECTRICAL SYSTEM	Inspect	2.0						E
		Repair		12.0	3.0			1, 7, 14, 15	
		Replace			12.0			7, 14, 15	
040404	COMMUNICATIONS EQUIPMENT								
04040401	VHF/FM HANDHELD TRANSCEIVER	Replace	1.0					1	
		Repair					8.0		
0405	LIGHT TOWER								
040501	ELECTRICAL SYSTEM	Test			1.0			10, 15	E
		Inspect			0.5			10, 15	E
		Repair			6.0			10, 15	

Table 1. MAC for Modular Causeway System. (MCS) (Continued)

(1) GROUP NO.	(2) COMPONENT/ASSEMBLY	(3) MAINTENANCE FUNCTION	(4) MAINTENANCE LEVEL					(5) TOOLS AND EQUIP REF CODE	(6) REMARKS CODE
			UNIT		DS	GS	DEPOT		
			C	O	F	H	D		
04050101	BATTERIES	Test			1.0			10, 13	E
		Inspect	0.5						E
		Replace		2.0				1	
04050102	OIL PRESSURE UNIT	Test			1.0			10	E
		Repair			1.0			10	
		Replace			1.5			10	
04050103	STARTING CIRCUIT	Repair			2.0			10, 15	
		Replace			3.0			10, 15	
04050104	ENGINE TEMPERATURE UNIT	Test			1.0			10, 18	E
		Repair			2.0			10, 18	
		Replace			2.5			10, 18	
04050105	HOUR METER UNIT	Repair			1.5			10	
		Replace			2.0			10	
04050106	SHUTDOWN CIRCUIT	Repair			2.0			10	
		Replace			4.0			10	
04050107	LAMP SYSTEM	Test	1.0						E
		Repair			2.0			10, 15	
		Replace			6.0			10, 15	
04050108	LAMP BALLAST SYSTEM	Test			0.5			10, 15	E
		Repair			2.0			10, 15	
		Replace			3.0			10, 15	
040502	GENERATOR	Clean		2.0				1	E
		Inspect					12.0		

Table 1. MAC for Modular Causeway System. (MCS) (Continued)

(1) GROUP NO.	(2) COMPONENT/ASSEMBLY	(3) MAINTENANCE FUNCTION	(4) MAINTENANCE LEVEL					(5) TOOLS AND EQUIP REF CODE	(6) REMARKS CODE
			UNIT		DS	GS	DEPOT		
			C	O	F	H	D		
040502	GENERATOR (CONT'D)	Repair					18.0		
		Replace					24.0		
04050202	CONTROL PANEL	Test	1.0						E
		Inspect	1.0						E
		Repair			3.0			10, 15	
		Replace			4.5			10, 15	
04050205	DIESEL ENGINE	Service	4.0	2.0				1	E
		Adjust		3.0				1	
		Repair				16.0		10	
		Overhaul					16.0		
		Replace			16.0			10	
0405020501	ENGINE FUEL SYSTEM	Inspect	1.0						E
		Repair		4.0				1	
		Replace			8.0			10	
040502050101	FUEL PUMP	Inspect	1.0						E
		Repair				4.0		10	
		Replace			5.0			10	
040502050102	FUEL TANK	Clean	2.0						E
		Inspect	1.0						E
		Repair		2.0				1	
		Replace		2.0				1	
0405020502	ENGINE AIR SYSTEM	Inspect	1.0						E
		Repair		2.0				1	
		Replace		4.0				1	

Table 1. MAC for Modular Causeway System. (MCS) (Continued)

(1) GROUP NO.	(2) COMPONENT/ASSEMBLY	(3) MAINTENANCE FUNCTION	(4) MAINTENANCE LEVEL					(5) TOOLS AND EQUIP REF CODE	(6) REMARKS CODE
			UNIT		DS	GS	DEPOT		
			C	O	F	H	D		
0405020503	ENGINE COOLING SYSTEM	Inspect	1.0						E
		Repair		3.0				1	
		Replace		7.0				1, 10	
040502050301	FAN ASSEMBLY	Inspect	0.5						E
		Repair		1.5				1	
		Replace		2.0				1	
040502050302	COOLING WATER PUMP	Inspect						10	E
		Repair				4.0		10	
		Replace			5.0			10	
040502050303	RADIATOR	Clean	1.0						E
		Inspect		1.0				1	E
		Service	2.0	4.0				1	E
		Repair				4.0		10	
		Replace		2.0	3.0			1, 10	
0405020504	CYLINDER HEAD	Inspect		1.0				1	E
		Adjust					2.0		
		Repair					8.0		
		Replace					5.0		
0405020505	VIBRATION DAMPER	Repair					4.0		
		Replace					4.0		
0405020506	EXHAUST SYSTEM	Inspect	0.5						E
		Clean	1.5						E
		Repair			3.0			1, 16	
		Replace			5.0			1	

Table 1. MAC for Modular Causeway System. (MCS) (Continued)

(1) GROUP NO.	(2) COMPONENT/ASSEMBLY	(3) MAINTENANCE FUNCTION	(4) MAINTENANCE LEVEL					(5) TOOLS AND EQUIP REF CODE	(6) REMARKS CODE
			UNIT		DS	GS	DEPOT		
			C	O	F	H	D		
0405020507	CRANKSHAFT	Inspect					4.0		
		Repair					8.0		
		Replace					8.0		
0405020508	PISTON	Inspect					4.0		
		Repair					4.0		
		Replace					4.0		
04050206	RUNNING GEAR	Service		2.0				1	E
		Repair		2.0				1, 10	
		Replace		18.0				1	
0405020601	TIRES	Inspect	0.5						E
		Repair				1.0		10	
		Replace				1.0		10	
04050207	SUPPORT TOWER	Inspect	0.5						E
		Service	1.0						E
		Repair			2.0			10	
		Replace			6.0			10	
04050208	TOWER RAISING ASSEMBLY	Inspect	0.5						E
		Repair			1.0			10	
		Replace			3.0			10	
04050209	ENCLOSURE	Inspect	0.5						E
		Repair			2.0			10	
		Replace			6.0			10	
0406	OFFSHORE ANCHOR	Clean	1.0						E
		Inspect	1.0						E

Table 1. MAC for Modular Causeway System. (MCS) (Continued)

(1) GROUP NO.	(2) COMPONENT/ASSEMBLY	(3) MAINTENANCE FUNCTION	(4) MAINTENANCE LEVEL					(5) TOOLS AND EQUIP REF CODE	(6) REMARKS CODE
			UNIT		DS	GS	DEPOT		
			C	O	F	H	D		
0406	OFFSHORE ANCHOR (CONT'D)	Repair			4.0			7	
		Replace		2.0				1	
0407	ONSHORE ANCHOR	Clean	1.0						E
		Inspect	1.0						E
		Repair			4.0			7	
	CONTAINERS	Replace		2.0				1	
0408		Clean	1.0						E
		Inspect	2.0						E
		Repair			4.0			7	
		Replace					8.0		

Table 2. Remarks for Modular Causeway System. (MCS)

REMARKS CODE	REMARKS
A	See MAC Chart for Causeway Ferry Diesel Engine Group Number 0101010101.
B	See MAC Chart for Causeway Ferry Marine Gear Group Number 0101010102.
C	See MAC Chart for Causeway Ferry Marine Gear Group Number 0101010103.
D	All repairs to the pump-jet must be done at depot level due to lack of technical information provided by the manufacturer, Schottel of Germany.
E	Preventive Maintenance Checks and Services (PMCS).
F	Includes replacement of level sensors, pump and motor.
G	Most work needs to be done by an authorized manufacturer's technical representative.
H	Refer to Army Technical Manual TM 11-5820-890-10-8.
I	Refer to Army Technical Manual TM 11-5825-291-13.
J	Includes cylinder liner, crankcase, crankcase breather and engine mounts.
K	Includes valves, springs, rocker arm, push rods, etc.

Table 2. Remarks for Modular Causeway System. (MCS) (Continued)

REMARKS CODE	REMARKS
L	Includes valves, main bearings, vibration damper and crankshaft pulley.
M	Includes drive shaft flex coupling.
N	Includes rings, connecting rod and connecting rod bearings.
O	Includes gear train, camshaft, idler gear, idler gear bearing, crankshaft timing gear, blower drive gear, and front and rear accessory drive gears.
P	Includes fuel water separator, fuel lines, fuel filter/strainer, fuel cooler, fuel manifold, fuel injector, fuel injector tube and valves.
Q	Includes air shutdown housing and air box check valves.
R	Includes intercooler and after cooler.
S	Includes lube oil pump driving gear, lube oil pressure regulator, lube oil relief valves, lube oil filter by-pass valve, lube oil cooler by-pass valve, lube oil pan and lube oil ventilation system.
T	Includes fresh water manifold and thermostat.
U	Includes raw water duplex strainer.
V	Includes starting batteries.
W	Rebuild of the marine gear is a depot level function.
X	Includes oil filter screen, pressure gage, temperature gage, selector valve, oil pump drive, output seal and gear mounts.
Y	Rebuild of the transfer case is a depot level function.
Z	See MAC Chart for Modular Warping Tug Diesel Engine Group Number 0301010101.
AA	See MAC Chart for Modular Warping Tug Marine Gear Group Number 0301010102.
AB	See MAC Chart for Modular Warping Tug Transfer Case Group Number 0301010103.
AC	Refer to Army Technical Manual TM 55-3950-204-14&P.
AD	Refer to Army Technical Manual TM 5-2815-258-24.
AE	Refer to Army Technical Manual TM 55-1925-257-14&P.

Table 3. Tools and Test Equipment for Modular Causeway System. (MCS)

TOOL OR TEST EQUIPMENT REF CODE	MAINTENANCE LEVEL	NOMENCLATURE	NATIONAL STOCK NUMBER	TOOL NUMBER
1	O	General Mechanics Rail and Marine Tool Kit	5180-00-629-9783	
2	O	Torque Wrench, 30-150 in. lbs 3/8 in. Drive	5120-00-230-6380	
3	O	Torque Wrench, 30-150 ft lbs 1/2 in. Drive	5120-00-247-2540	
4	D	Torque Wrench, 100-500 ft lbs	5120-00-542-5577	
5	D	Pinch Pry Bar 60	5120-00-224-1384	
6	D	Hammer, Hand, (sledge hammer) 10 lb	5120-00-251-4489	
7	D	General Mechanics Tool Kit	5180-00-177-7033	
8	O	Hammer, Hand, Scaling	5120-00-224-4111	
9	O	Wire Brush	7920-00-291-5815	
10	D	Automotive Tool Kit	5810-00-177-7033	
11	O	Wrench, Strap	5120-00-776-1840	
12	D	Wrench, Monkey	5120-00-277-3120	
13	D	Tester, Antifreeze Solution	6630-00-105-1418	
14	O	Fuse Puller and Tester	5120-00-319-3295	
15	O	Multimeter	6625-01-262-4815	
16	O	Welder Tool Kit	5180-00-754-0661	
17	D	Dial Indicator	5120-00-402-9619	
18	D	Thermometer, Test	6685-00-056-3109	
19	G	Wheel Puller		
20	D	Pliers, Snap Ring		
21	D	Tool Kit, Compressor	5180-01-267-2907	
22		Deleted	Deleted	
23	O	Blast Cleaning Machine (Power Washer)	4940-00-168-2173	

■ **Table 3. Tools and Test Equipment for Modular Causeway System. (MCS) (Continued)**

TOOL OR TEST EQUIPMENT REF CODE	MAINTENANCE LEVEL	NOMENCLATURE	NATIONAL STOCK NUMBER	TOOL NUMBER
24	O	Scraper, Long Handle		
25	O	Air Tester		
26	O	Air Compressor		
27	D	Adaptor (1 5/8 in. Dia plugs) (Cylinder Block)		J21850
28	D	Aftercooler Adaptor Cup Plug Installer		J28711
29	D	Aftercooler Adaptor Plug Remover and Installer		J25275
30	D	Aftercooler Cup Plug Installer (2 1/2 in. Dia)		J24597
31	D	Alignment Tool		J21799
32	D	Block Assembly Wrench Set		J25451-B
33	D	Block Thread Repair Kit		J29513
34	D	Cup Plug Installer (1 in. Dia)		J33420
35	D	Cylinder Block Air Box Plugging Tool		J29571
36	D	Cylinder Block Line Boring Tool		J29005
37	D	Cylinder Block Tap		J25384
38	D	Cylinder Diameter Checking Gage		J5347-B
39	D	Cylinder Hone Set (2 1/2 in. to 5 3/4 in.)		J5902-01
40	D	Dial Bore Gage Master Setting Fixture		J23059-01
41	D	Dial Indicator Set		J22273-01
42	D	Diesel Engine Parts Dolly		J6387
43	D	Handle		J7079-02
44	D	Loctite "Chisel" Gasket Remover		PT7275
45	D	Master Ring Gage for Block Bore		J24564

■ Table 3. Tools and Test Equipment for Modular Causeway System. (MCS) (Continued)

TOOL OR TEST EQUIPMENT REF CODE	MAINTENANCE LEVEL	NOMENCLATURE	NATIONAL STOCK NUMBER	TOOL NUMBER
46	D	Overhaul Stand (6V and 8V engines)		J29109
47	D	Overhaul Stand (12V and 16V engines)		J9384-04
48	D	Overhaul Stand Adaptor (6V and 8V engines)		J33850
49	D	Overhaul Stand Adaptor (12V and 16V engines)		J8650
50	D	Pipe Plug Remover/Installer (1/8 in. Dia)		J34650
51	D	Special Plug Remover (dry cylinder block)		J21995-01
52	D	Special Plug Remover		J23019
53	D	Load Cell Kit, Cam Follower Roller Fixture (Cylinder Head)		J33421-25
54	D	Cam Follower Service Fixture		J33421-A
55	D	Cylinder Head Bolt Hole Cleanout Tap		J25384
56	D	Cylinder Head Guide Studs (set of two)		J24748
57	D	Cylinder Head Holding Plate Set		J3087-01
58	D	Cylinder Head Lifting Fixture		J22062-01
59	D	Engine Barring Tool		J22582
60	D	Feeler Gage Set (.0015 in. to .015 in.)		J3172
61	D	Feeler Stock (.0015 in.)		J23185
62	D	Fuel Line Nut Wrench		J8932B
63	D	Injector Fuel Hole Brush		J8152
64	D	Pressure Checking Tool		J28454
65	D	Push Rod Remover (set of three)		J3092-01
66	D	Slide Hammer		J2619-01

■ **Table 3. Tools and Test Equipment for Modular Causeway System. (MCS) (Continued)**

TOOL OR TEST EQUIPMENT REF CODE	MAINTENANCE LEVEL	NOMENCLATURE	NATIONAL STOCK NUMBER	TOOL NUMBER
67	D	Spring Tester		J22738-02
68	D	Valve Bridge Holding Fixture		J21772
69	D	Valve Bridge Gage Remover (broken)		J7453
70	D	Valve Bridge Guide Remover Set		J7091-01
71	D	Valve Bridge Guide Installer		J7482
72	D	Valve Guide Cleaner		J5437
73	D	Valve Guide Installer (machined)		J21520
74	D	Valve Guide Remover		J6569-A
75	D	Valve Seat Dial Gage		J8165-2
76	D	Valve Guide Oil Seal Installer		J35373
77	D	Valve Seat Grinder (Model VIP)		J7040-A
78	D	Valve Seat Grinder		J8165-1A
79	D	Valve Seat Grinder Adaptor Set		J24566
80	D	Valve Seat Insert Installer		J24357
81	D	Valve Seat Insert Remover Assembly		J23479-492
82	D	Valve Seat Insert Remover Collet		J23479-33
83	D	Valve Spring Checking Gage		J25076-B
84	D	Valve Spring Compressor		J7455-A
85	D	Water Nozzle Installer (intermediate)		J24857-A
86	D	Front Oil Seal Installer (6V and 8V) (Crankshaft)		J9783
87	D	Rear Oil Seal Installer (std and ovs seals)		J21112-B
88	D	Handle		J3154-A
89	D	Guide Studs (c/s with dowels)		J9727-2
90	D	Guide Studs (c/s without dowels)		J9727-5

■ **Table 3. Tools and Test Equipment for Modular Causeway System. (MCS) (Continued)**

TOOL OR TEST EQUIPMENT REF CODE	MAINTENANCE LEVEL	NOMENCLATURE	NATIONAL STOCK NUMBER	TOOL NUMBER
91	D	Expander (std seal)		J4239
92	D	Handle		J8092
93	D	Guide Studs		J25002
94	D	Expander (ovs seal, no handle or guide studs)		J8682
95	D	Sleeve Installer (ovs seal)		J21983
96	D	Installer		J9727-A
97	D	Handle		J3154-1A
98	D	Expander (std seal, no handle)		J22425-A
99	D	Expander (ovs seal, no handle or guide studs)		J4195-01
100	D	Installer (ovs seal)		J4194-01
101	D	Dial Indicator Set		J5959-01
102	D	Engine Barring Tool		J22582
103	D	Flywheel Housing Alignment Studs		J1927-01
104	D	Micrometer Ball Attachment		J4757
105	D	Torque Wrench Adaptor (12V and 16V engines)		J22898-A
106	D	Universal Bar Type Puller		J24420-B
107	D	Flywheel Lifting Fixture (Flywheel)		J25026
108	D	Flywheel Lifting Tool		J6361-01
109	D	Oil Seal Removing and Replacing Tool Set		J3154-04
110	D	Slide Hammer Set		J5901-01
111	D	Flywheel Housing Aligning Studs (set of four) (Flywheel Housing)		J1927-01
112	D	Flywheel Housing Concentricity Gage Set		J9734-C

■ **Table 3. Tools and Test Equipment for Modular Causeway System. (MCS) (Continued)**

TOOL OR TEST EQUIPMENT REF CODE	MAINTENANCE LEVEL	NOMENCLATURE	NATIONAL STOCK NUMBER	TOOL NUMBER
113	D	Connecting Rod Holding Fixture (Piston, Connecting Rod and Cylinder Liner)		J7632
114	D	Cylinder Liner Master Ring Gage		J24564
115	D	Cylinder Hone Set (2½ in. to 5¾ in. range)		J5902-01
116	D	Cylinder Liner Hold-Down Tool		J24565-02
117	D	Cylinder Liner Remover Set		J24563-A
118	D	Dial Bore Gage Setting Fixture		J23059-01
119	D	Dial Indicator Set		J24898
120	D	Feeler Gage Set		J3172
121	D	Micrometer Ball Attachment		J4757
122	D	Piston Crown Identification Gage		J25397-A
123	D	Piston Pin Alignment Tool		J24285
124	D	Piston Pin Retainer Installer		J23762-A
125	D	Piston Pin Retainer Leak Detector (plastic)		J23987-B
126	D	Deleted		Deleted
127	D	Piston Ring Compressor		J24227
128	D	Piston Ring Remover Installer		J8128
129	D	Piston to Liner Feeler Gage Set		J5438-01
130	D	Seal Ring Compressor		J24226
131	D	Accessory Drive Hub Oil Seal Aligning Tool (Camshaft)		J21166
132	D	Alternator Drive Step-Up Gear Aligning Gage		J29893
133	D	Balance Weight Cover Oil Seal Installer		J9791
134	D	Camshaft Gear Puller		J1902-B

■ **Table 3. Tools and Test Equipment for Modular Causeway System. (MCS) (Continued)**

TOOL OR TEST EQUIPMENT REF CODE	MAINTENANCE LEVEL	NOMENCLATURE	NATIONAL STOCK NUMBER	TOOL NUMBER
135	D	Camshaft Gear Puller Adaptor Plate Set		J6202-01
136	D	Camshaft and Oil Pump Gear Installer		J1903
137	D	Dial Indicator and Attachment Set		J5959-01
138	D	Puller Adaptor		J7932
139	D	Slide Hammer Set		J6471-02
140	D	Spring Scale		J8129
141	D	Universal Bar Type Puller		J24420-B
142	D	Pullers (Fuel & Governors)		J6270-1
143	D	Oil Seal Remover and Installer		J6270-3
144	D	Buffing Wheel (brass wire)		J7944
145	D	Fuel Pipe Socket		J8932-B
146	D	Fuel System Primer		J5956
147	D	Injector Auxiliary Tester		J22640-A
148	D	Injector Body Reamer		J21089
149	D	Injector Calibrator		J22410
150	D	Injector Carbon Remover Set		J9418
151	D	Injector Holding Fixture		J22396
152	D	Injector Nut Seal Ring Installer		J29197
153	D	Injector Service Tool Set		J23435-C
154	D	Body Brush		J8152
155	D	Nut Socket Wrench		J4983-01
156	D	Rack Hole Brush		J8150
157	D	Spray Hole Cleaner Vice		J4298-1
158	D	Spray Tip Carbon Remover (high sack)		J9464-01

■ **Table 3. Tools and Test Equipment for Modular Causeway System. (MCS) (Continued)**

TOOL OR TEST EQUIPMENT REF CODE	MAINTENANCE LEVEL	NOMENCLATURE	NATIONAL STOCK NUMBER	TOOL NUMBER
159	D	Spray Tip Carbon Remover (low sack)		J24838
160	D	Spray Tip Driver and Brushing Cleaner		J129101
161	D	Wire Sharpening Stone		J8170
162	D	Injector Tag Remover and Installer		J24767
163	D	Injector Test Oil (5, 10, 30 and 55 GAL)		J26400
164	D	Injector Tester		J23010-B
165	D	DDEC Injector Adaptor Kit		J23010-500
166	D	Lapping Block Set		J22090-A
167	D	Master Injector Calibrating Kit		J35369
168	D	Needle Valve Lift Gage		J9462-02
169	D	Polishing Compound		J23038
170	D	Polishing Stick Set		J22964
171	D	Spray Tip Cleaning Wire (.007 in. Dia holes)		J21462-01
172	D	Spray Tip Flow Gage		J25600-B
173	D	Field Modification Kit		J25600-103
174	D	Spring Tester		J29196
175	D	Tip Conical. Gage and Rack Freeness Tester		J29584
176	D	Cylinder Head Holding Plate Set		J3087-01
177	D	Cylinder Liner Depth Gage		J22273-01
178	D	Injector Protrusion Gage		J25521
179	D	Injector Tube Service Tool Set		J22525-B
180	D	Injector Tube Swaging Tool		J28611-A
181	D	Fuel Pump Tool Set		J1508-E

■ Table 3. Tools and Test Equipment for Modular Causeway System. (MCS) (Continued)

TOOL OR TEST EQUIPMENT REF CODE	MAINTENANCE LEVEL	NOMENCLATURE	NATIONAL STOCK NUMBER	TOOL NUMBER
182	D	Fuel Pump Wrench		J4242
183	D	Control Link Operating Lever Bearing Remover and Installer		J8985
184	D	Governor Cover Bearing Installer		J21068
185	D	Governor Cover Bearing Remover and Installer		J21967-01
186	D	High Speed Spring Retainer and Installer		J5345-12
187	D	Governor Weight Shaft Retaining Ring Installer		J36840
188	D	Blower Alignment Tool (Air System)		J33001
189	D	Blower Clearance Feeler Set		J1698-02
190	D	Blower Service Tool Set		J6270-G
191	D	Installer, Lip Type Oil Seal/Water Sleeve		J35787-A
192	D	Dial Indicator Set (magnetic base)		J7872
193	D	Turbocharger Inlet Shield		J26554-A
194	D	Adaptor Cup Plug Installer		J28711
195	D	Adaptor Plug Remover and Installer		J25275
196	D	Bar Type Gear Puller (Lubrication System)		J24420
197	D	Oil Pump Drive Gear Installer (16V)		J9380
198	D	Oil Pump Drive Shaft Gear Installer (6V and 8V)		J22397
199	D	Oil Pump Driven Gear Installer (16V)		J9381
200	D	Oil Pump Driven Shaft Gear Installer (6V and 8V)		J22398

■ **Table 3. Tools and Test Equipment for Modular Causeway System. (MCS) (Continued)**

TOOL OR TEST EQUIPMENT REF CODE	MAINTENANCE LEVEL	NOMENCLATURE	NATIONAL STOCK NUMBER	TOOL NUMBER
201	D	Oil Pump Driving Gear Installer (6V and 8V)		J22285
202	D	Spring Tester (1-125 lbs)		J29196
203	D	Strap Wrench (spin-on filter)		J24783
204	D	Cooling System Radiator Cap Pressure Tester (Cooling System)		J24460-01
205	D	Fingers, Fan Hub Nut Socket (16V)		J6534-8
206	D	Handle		J7079-2
207	D	Oil Seal Installer		J8501
208	D	Pliers		J4646
209	D	Puller		J24420-A
210	D	Socket, Fan Hub Nut (16V)		J22556-2
211	D	Thermostat Seal Installer		J8550
212	D	Water Pump Bearing and Gear Installer		J25257
213	D	Water Pump Impeller/Gear Slip Torque Tool		J33765
214	D	Water Pump Seal Remover Set		J22150-B
215	D	Water Pump Impeller Slip Checking Fixture		J34034
216	D	Slide Hammer (Electrical Equipment)		J23907-1
217	D	Tachometer Drive Alignment Tool Set		J23068
218	D	Tachometer Drive Shaft Remover		J5901-3
219	O	Coveralls, Eye Protection, Respirator, Gloves (Zodiac Boat Hull)		
220	O	Grease Pencil Or Chalk		

■ **Table 3. Tools and Test Equipment for Modular Causeway System. (MCS) (Continued)**

TOOL OR TEST EQUIPMENT REF CODE	MAINTENANCE LEVEL	NOMENCLATURE	NATIONAL STOCK NUMBER	TOOL NUMBER
221	O	Saber Saw With Metal Cutting Blades		
222	D	Grinder or Disc Sander w/ Coarse Medium Grit		
223	O	Measuring Tape		
224	D	Scissors, Shears		
225	O	Cardboard, Kraft Paper		
226	D	Disposable Containers, Mixing Sticks		
227	D	Disposable Brushes, Putty Knife		
228	D	Polyethylene Sheet		
229	D	Heavy Cardboard, Thin Plywood, Sheet Metal		
230	D	Acetone		

**OPERATOR MAINTENANCE
CAUSEWAY FERRY
COMPONENTS OF END ITEM (COEI) LIST**

INTRODUCTION

Scope

This work package lists COEI for the causeway ferry to help you inventory items for safe and efficient operation of the equipment.

General

This list is for information purposes only and is not authority to requisition replacements. These items are part of the causeway ferry. As part of the end item, these items must be with the end item whenever it is issued or transferred between property accounts. Items of COEI are removed and separately packaged for transportation or shipment only when necessary. Illustrations are furnished to help you find and identify the items.

Explanation of Columns in the COEI List

Column (1) - Illus Number. Gives you the number of the item illustrated.

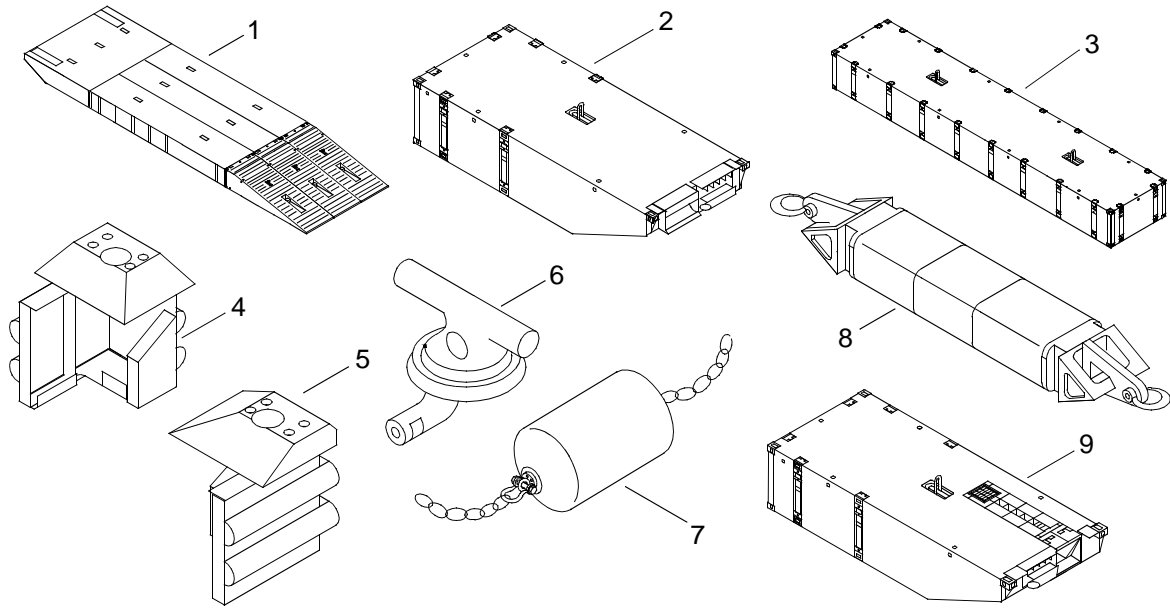
Column (2) - National Stock Number (NSN). Identifies the stock number of the item to be used for requisitioning purposes.

Column (3) - Description, CAGEC, and Part Number. Identifies the Federal item name followed by a minimum description when needed. The stowage location of COEI is also included in this column. The last line below the description is the CAGEC (commercial and government entity code) (in parentheses) and the part number.

Column (4) - Usable on Code. When applicable, gives you a code if the item you need is not the same for different models of equipment.

Column (5) - Unit of Measure (U/M). Indicates the physical measurement or count of the item as issued per the National Stock Number shown in column (2).

Column (6) - Qty Rqd. Indicates the quantity required.



■ **Table 1. Component of End Item. (COEI)**

(1) ILLUS NUMBER	(2) NATIONAL STOCK NUMBER	(3) DESCRIPTION, CAGEC AND PART NUMBER	(4) USABLE ON CODE	(5) U/M	(6) QTY RQD
1		BEACH END MOD ASSEMBLY (ISOPAK) (34712) E02853		EA	3
2		CENTER END RAKE (ISOPAK) (34712) E02823		EA	7
3		CENTER MODULE (ISOPAK) (34712) E02803		EA	10
4		CORNER FENDER (left hand) (BII container) (81340) MCS-582-004-15 LH		EA	2
5		CORNER FENDER (right hand) (BII container) (81340) MCS-582-004-15 RH		EA	2
6		D-RING MOORING ASSEMBLY (34712) E07803		EA	8
7		FENDER ASSEMBLY (20 ft end-opening container) (5R766) UPCFENDER2X4		EA	12
8	2040-01-092-3081	FLEXOR COUPLING, PONTOON CAUSEWAY (left hand rakes) (80091) 6138992		EA	7
9		LEFT END RAKE (ISOPAK) (34712) E02833		EA	7

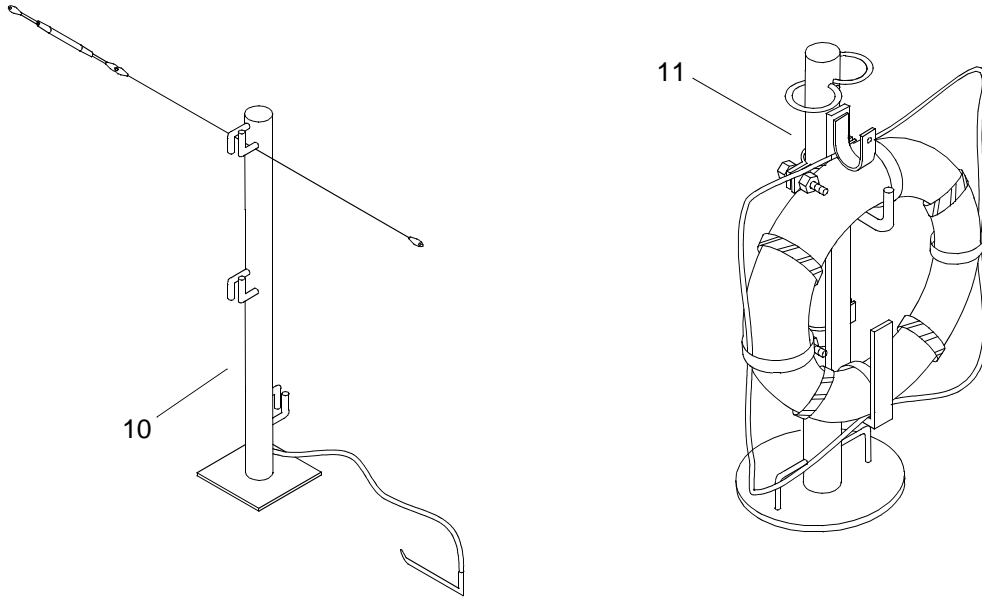


Table 1. Component of End Item. (COEI)

(1) ILLUS NUMBER	(2) NATIONAL STOCK NUMBER	(3) DESCRIPTION, CAGEC AND PART NUMBER	(4) USABLE ON CODE	(5) U/M	(6) QTY RQD
10		LIFELINES AND STANCHION ASSEMBLY (BII container) (34712) E03136		EA	1
11	4220-00-275-3157 6230-01-143-4778	LIFE RING BUOY AND STANCHION ASSEMBLY (BII container) Consisting of: Ring, Buoy, Life Saving (81340) SUBPART 160.050-30 IN Light, Marker, Distress (0FDD9)SS777 Hanger, Bracket (06101) MCS-01-612-010-3 Stanchion (06101) MCS-01-612-010-1 Rubber Strip (39428) 9013K52 Nut (39428) 90473A031 Bolt (39428) 91309A628 Bracket Half (06101) MCS-01-612-010-4 Retainer (06101) MCS-01-612-010-2 Bolt (39428) 92245A716		EA	4

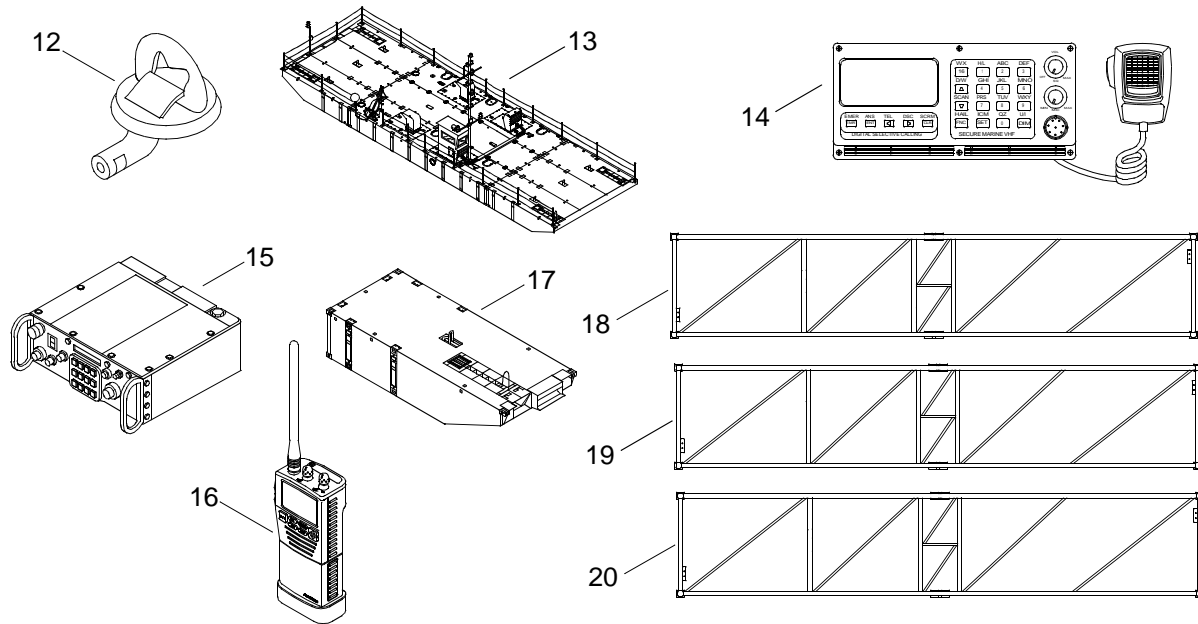


Table 1. Component of End Item. (COEI)

(1) ILLUS NUMBER	(2) NATIONAL STOCK NUMBER	(3) DESCRIPTION, CAGEC AND PART NUMBER	(4) USABLE ON CODE	(5) U/M	(6) QTY RQD
12		MOORING CLEAT ASSEMBLY (34712) E02783		EA	8
13		PROPULSION MODULE (34712) E28403		EA	2
14		RADIO SET (pilothouse) (0WF67) DSC 500		EA	1
15		RADIO SET (pilothouse) (80063) A3080229-1		EA	1
16		RECEIVER/XMTR (BII container) (0JDM6) 50-200029		EA	2
17		RIGHT END RAKE (ISOPAK) (34712) E02813		EA	7
18		SHIPPING RACK (ISOPAK) (19207) FCMWT-98-699-001		EA	2
19		SHIPPING RACK, MAST (ISOPAK) (19207) FCMWT-98-699-001, Arrangement 2		EA	1
20		SHIPPING RACK, PLENUM (ISOPAK) (19207) FCMWT-98-699-002, Arrangement 1		EA	1

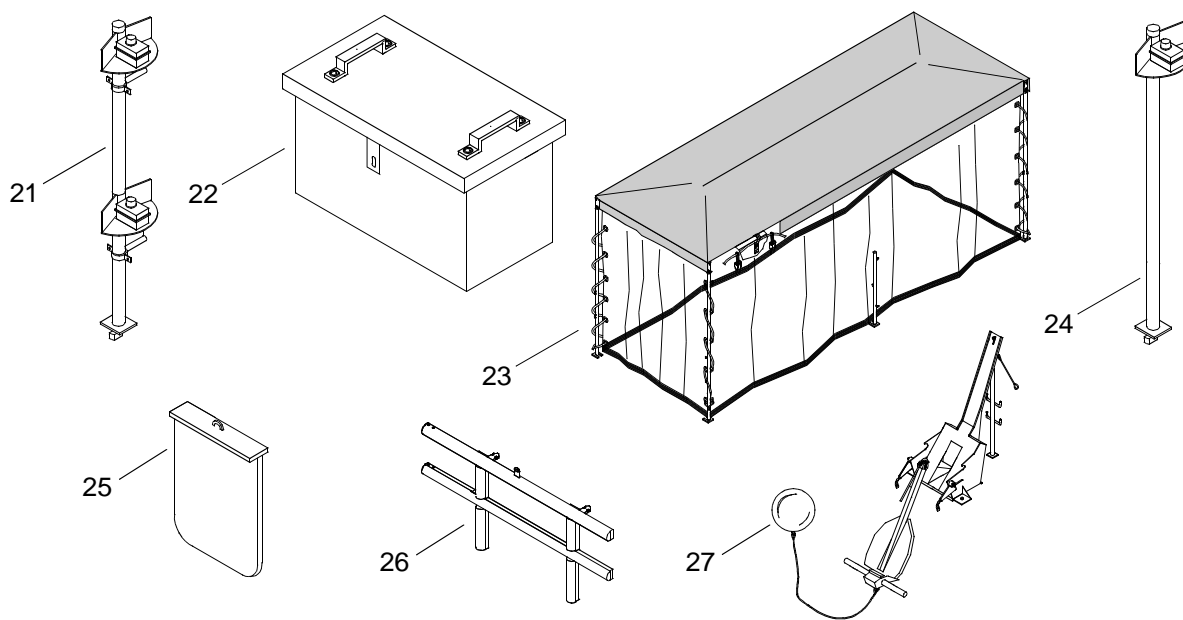


Table 1. Component of End Item. (COEI)

(1) ILLUS NUMBER	(2) NATIONAL STOCK NUMBER	(3) DESCRIPTION, CAGEC AND PART NUMBER	(4) USABLE ON CODE	(5) U/M	(6) QTY RQD
21		STERN MAST NAVIGATION LIGHT (81340) MCSWT-02-422-001		EA	1
22		DECK BOX (81340) MCSWT-02-671-003		EA	2
23		CREW SHELTER (81340) MCSWT-02-613-001		EA	1
24		BOW MAST ASSEMBLY (BII container) (06101) MCS-01-422-001		EA	1
25		SKEG (19207) MCS-02-114-001		EA	4
26		SIDE FENDER (81340) MCSWT-02-583-001		EA	16
27		ANCHORBOARD ASSEMBLY (34712) E20053		EA	1
28		BII CONTAINER (NOT SHOWN) (06101) MCS 99-673-001		EA	1
29		CONTAINER, SHIPPING (NOT SHOWN) (IRQA1) CMCONTAINER20		EA	3

■ **Table 1. Component of End Item. (COEI)**

(1) ILLUS NUMBER	(2) NATIONAL STOCK NUMBER	(3) DESCRIPTION, CAGEC AND PART NUMBER	(4) USABLE ON CODE	(5) U/M	(6) QTY RQD
ON BOARD SPARES					
30		TWIST LOCKS, HORIZONTAL (BII container) (059E5) BLR1212		EA	2
31		TWIST LOCKS, VERTICAL (BII container) (94658) F633L-C		EA	4

**OPERATOR MAINTENANCE
CAUSEWAY FERRY
BASIC ISSUE ITEMS LIST (BII)**

INTRODUCTION

Scope

This work package lists BII for the causeway ferry to help you inventory items for safe and efficient operation of the equipment.

General

These essential items are required to place the causeway ferry in operation, operate it, and to do emergency repairs. Although shipped separately packaged, BII must be with the causeway ferry during operation and when it is transferred between property accounts. Listing these items is your authority to request/requisition them for replacement based on authorization of the end item by the TOE/MTOE. Illustrations are furnished to help you find and identify the items.

Explanation of Columns in the BII List

Column (1) - Illus Number. Gives you the number of the item illustrated.

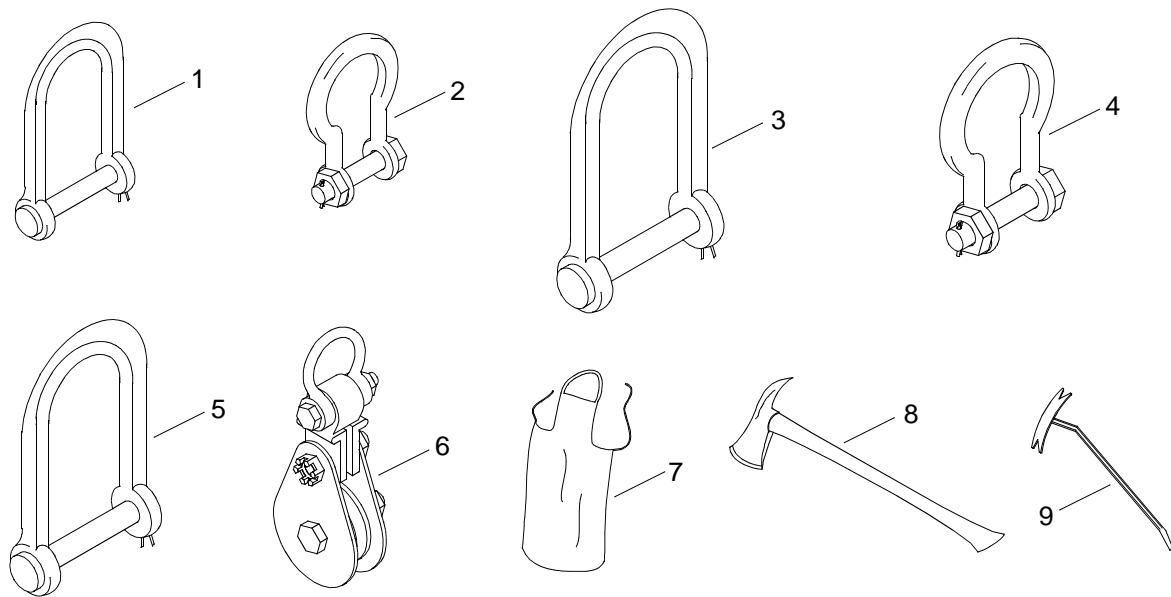
Column (2) - National Stock Number (NSN). Identifies the stock number of the item to be used for requisitioning purposes.

Column (3) - Description, CAGEC, and Part Number. Identifies the Federal item name followed by a minimum description when needed. The stowage location of BII is also included in this column. The last line below the description is the CAGEC (Commercial and Government Entity Code) (in parentheses) and the part number.

Column (4) - Usable on Code. When applicable, gives you a code if the item you need is not the same for different models of equipment.

Column (5) - Unit of Measure (U/M). Indicates the physical measurement or count of the item as issued per the National Stock Number shown in column (2).

Column (6) - Qty Rqd. Indicates the quantity required.



■ **Table 1. Basic Issue Items. (BII)**

(1) ITEM NUMBER	(2) NATIONAL STOCK NUMBER	(3) DESCRIPTION, CAGEC AND PART NUMBER	(4) USABLE ON CODE	(5) U/M	(6) QTY RQD
1		2-TON 1/2 in. ANCHOR SHACKLE (75535) 1019472		EA	8
2		30-TON 1-1/2 in. ANCHOR BOLT SHACKLE (75535) 1021110		EA	4
3		3-1/4 TON 5/8 in. SHACKLE (75535) 1019490		EA	8
4		40-TON 1-3/4 in. ALLOY ANCHOR SHACKLE (75535) 1021138		EA	4
5	4030-00-343-5433	4-3/4 TON 3/4 in. SHACKLE (75535) 1019515		EA	8
6		8 in. SNATCH BLOCK (75535) 121022		EA	4
7	8415-00-082-6108	APRON, UTILITY (64067) 8415-00-082-6108		EA	2
8	4210-00-142-4949	AX, PICKHEAD (76109) GGGA296TYPE2		EA	1
9	5120-00-242-0762	BAR, WRECKING (57068) 55-136		EA	2

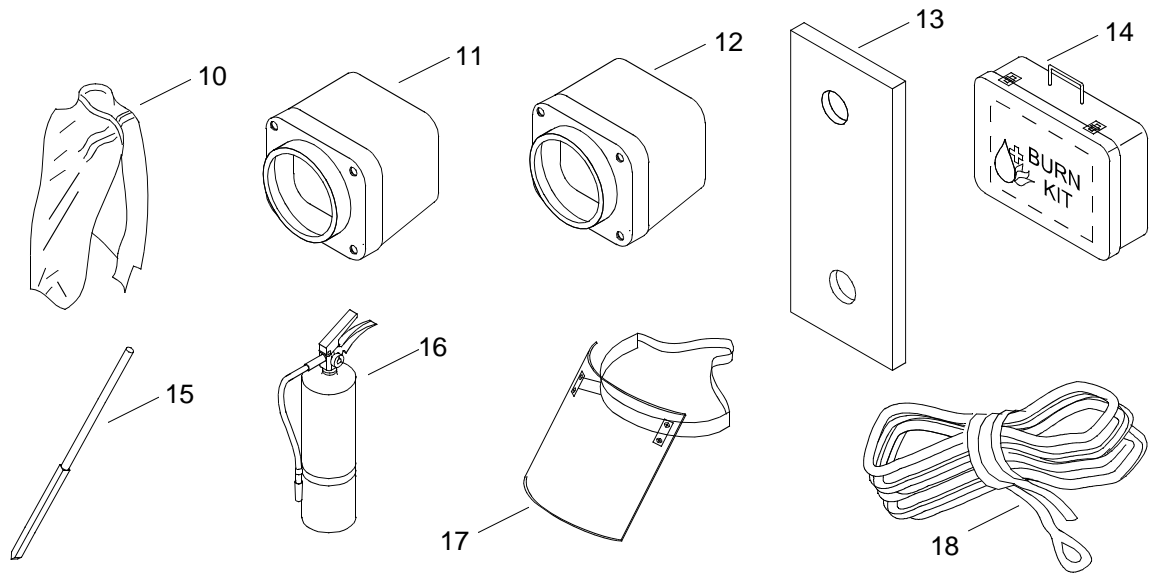
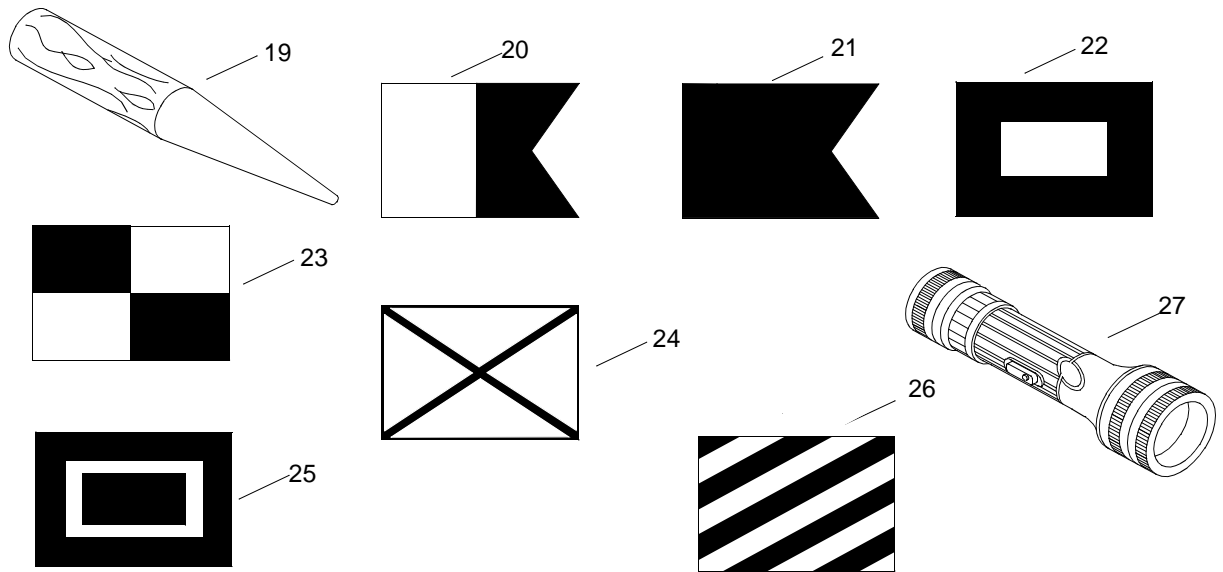


Table 1. Basic Issue Items. (BII) (Continued)

(1) ITEM NUMBER	(2) NATIONAL STOCK NUMBER	(3) DESCRIPTION, CAGEC AND PART NUMBER	(4) USABLE ON CODE	(5) U/M	(6) QTY RQD
10	6510-01-439-0862	BLANKET, BURN (1BJ97) 7260C		PG	1
11	6230-00-783-6519	BODY ASSEMBLY, LANTERN (red) (81349) MIL-F-16377-53		EA	1
12	6230-00-783-6519	BODY ASSEMBLY, LANTERN (81349) MIL-F-16377-53		EA	3
13	6230-00-968-7831	BRACKET (81349) MIL-F-16377-53		EA	3
14	6515-01-309-3444	BURN CARE KIT, MEDICAL (06345) B95190		EA	1
15	5120-00-224-1390	CROWBAR (58536) A-A-2563		EA	2
16	4210-00-203-0217	EXTINGUISHER, FIRE (15 lb) (81349) MIL-E-24269		EA	3
17	4220-00-542-2048	FACESHIELD, INDUSTRIAL (80204) ANSI Z87.1		EA	6
18	4020-01-387-8795	FIBER ROPE ASSEMBLY, SINGLE LEG (64249) 228		EA	2



■ **Table 1. Basic Issue Items. (BII) (Continued)**

(1) ITEM NUMBER	(2) NATIONAL STOCK NUMBER	(3) DESCRIPTION, CAGEC AND PART NUMBER	(4) USABLE ON CODE	(5) U/M	(6) QTY RQD
19	5120-00-223-8921	FID (80244) A-A-52129		EA	2
20	8345-00-935-0445	FLAG, SIGNAL ("A" INTL CODE SIZE 6) (81349) MIL-F-2692		EA	1
21	8345-00-926-6803	FLAG, SIGNAL ("B" INTL CODE SIZE 6) (80064) 16696SHEET6B		EA	1
22	8345-00-935-0451	FLAG, SIGNAL ("O" INTL CODE SIZE 6) (81349) MIL-F-2692		EA	1
23	8345-00-926-6814	FLAG, SIGNAL ("U" INTL CODE SIZE 6) (81349) MIL-F-2692		EA	1
24	8345-00-935-0455	FLAG, SIGNAL ("V" INTL CODE SIZE 6) (81349) MIL-F-2692		EA	1
25	8345-00-935-0456	FLAG, SIGNAL ("W" INTL CODE SIZE 6) (81349) MIL-F-2692		EA	1
26	8345-00-935-0457	FLAG, SIGNAL ("Y" INTL CODE SIZE 6) (81349) MIL-F-2692		EA	1
27	6230-00-264-8261	FLASHLIGHT (81349) MIL-F-3747		EA	2

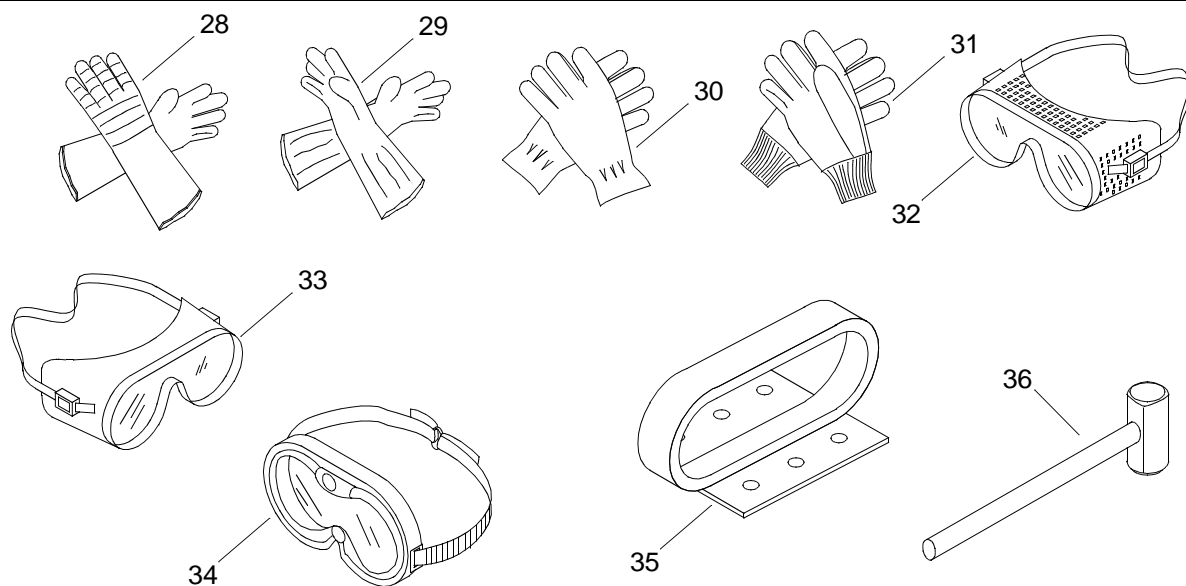
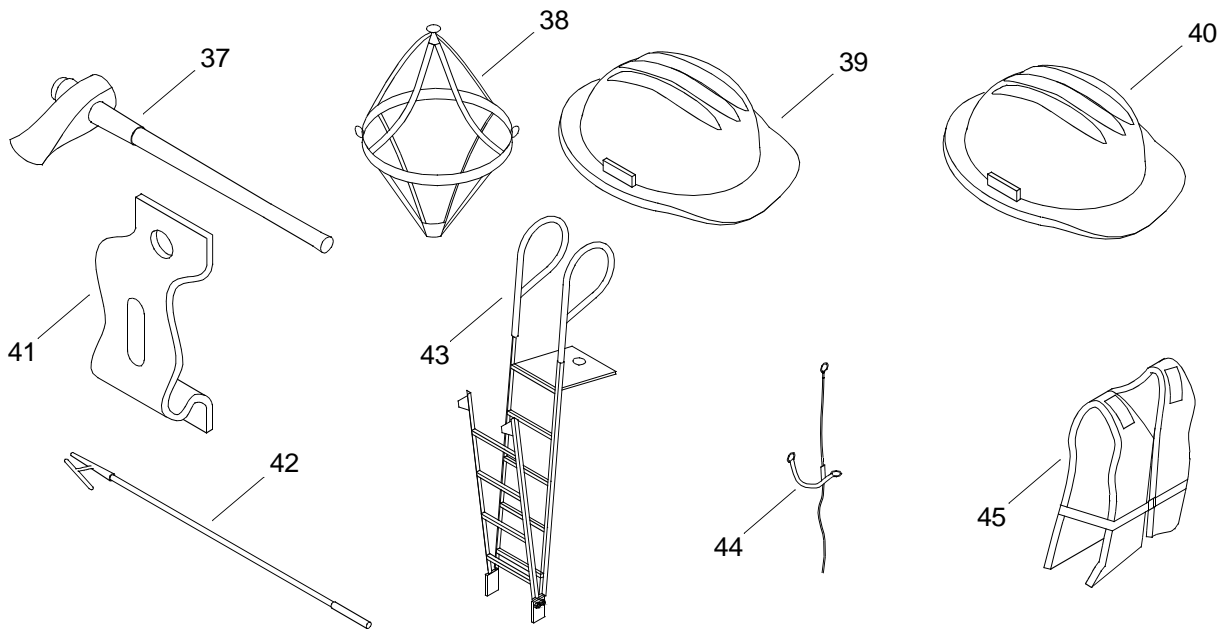


Table 1. Basic Issue Items. (BII) (Continued)

(1) ITEM NUMBER	(2) NATIONAL STOCK NUMBER	(3) DESCRIPTION, CAGEC AND PART NUMBER	(4) USABLE ON CODE	(5) U/M	(6) QTY RQD
28	8415-01-267-9661	GLOVES, ANTIFLASH (81349) MIL-G-2874		PR	6
29	8415-00-266-8677	GLOVES, CHEMICAL (81349) ZZ-G-381		PR	2
30	8415-00-266-8691	GLOVES, ELECTRICAL (81348) ZZ-G-401		PR	6
31	8415-00-634-4658	GLOVES, MEN'S AND WOMEN'S (leather palm) (81348) ZZ-G-401		PR	6
32	4240-00-052-3776	GOGGLES, INDUSTRIAL (chipping, chemical) (80204) ANSI Z87.1		PR	6
33	4240-00-190-6432	GOGGLES, INDUSTRIAL (58536) A-A-110		PR	2
34	8465-01-004-2893	GOGGLES, SUN, WIND AND DUST (safety) (81349) MIL-G-43914		PR	6
35	6230-00-776-5920	GRIP, HANDLE (81349) MIL-F-16377-53		EA	3
36	5120-00-243-2957	HAMMER, HAND (10 lb sledge) (58536) 75H		EA	2



■ **Table 1. Basic Issue Items. (BII) (Continued)**

(1) ITEM NUMBER	(2) NATIONAL STOCK NUMBER	(3) DESCRIPTION, CAGEC AND PART NUMBER	(4) USABLE ON CODE	(5) U/M	(6) QTY RQD
37	5120-00-255-1476	HAMMER, HAND (5 lb ship's maul) (58536) A-A-1285		EA	1
38	4240-00-022-2522	HARNESS, SAFETY INDUSTRIAL (55799) 502644		EA	6
39	8415-00-279-2205	HELMET, SAFETY (blue) (80204) ISEA/ANSI Z89.1		EA	2
40	8415-00-823-7575	HELMET, SAFETY (brown) (3A054) 913IT34		EA	4
41	6230-00-578-7401	HOLDER, LIGHT (81349) MIL-F-16377/54		EA	3
42	2040-00-268-9250	HOOK, BOAT (21530) H389		EA	2
43		LADDER (06101) MCS-99-673-001-128		EA	2
44	4240-00-022-2518	LANYARD, SAFETY HARNESS (80204) ANSI Z359.1		EA	6
45	4220-00-276-8926	LIFE PRESERVER, VEST (work vest) (81349) MIL-L-17653		EA	8

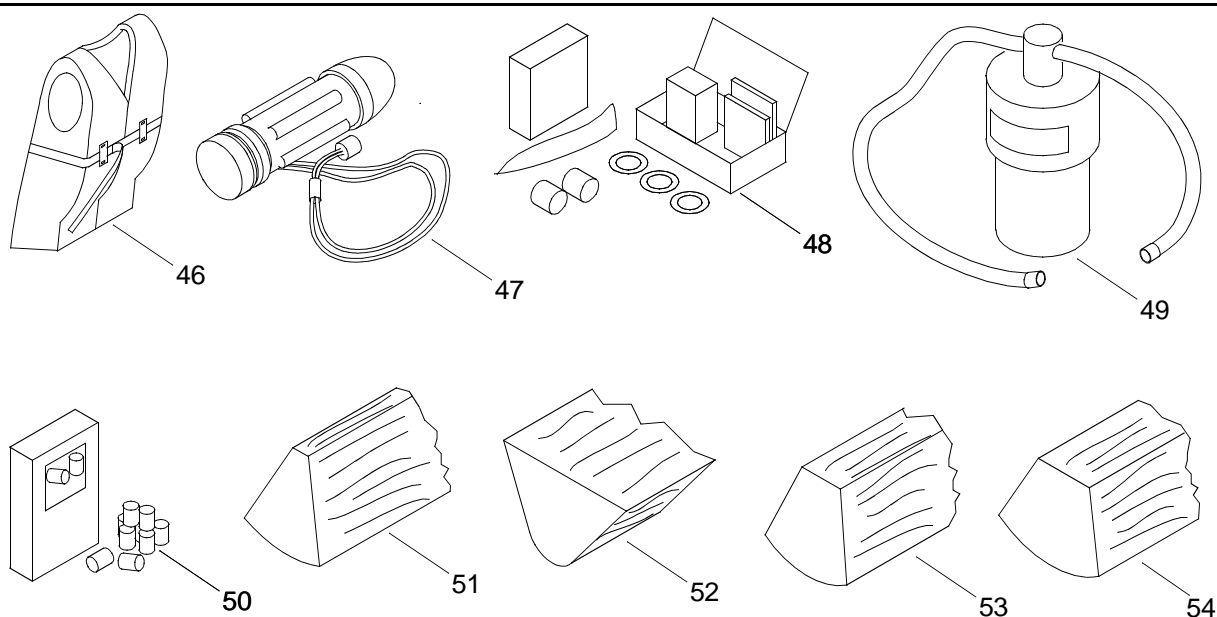
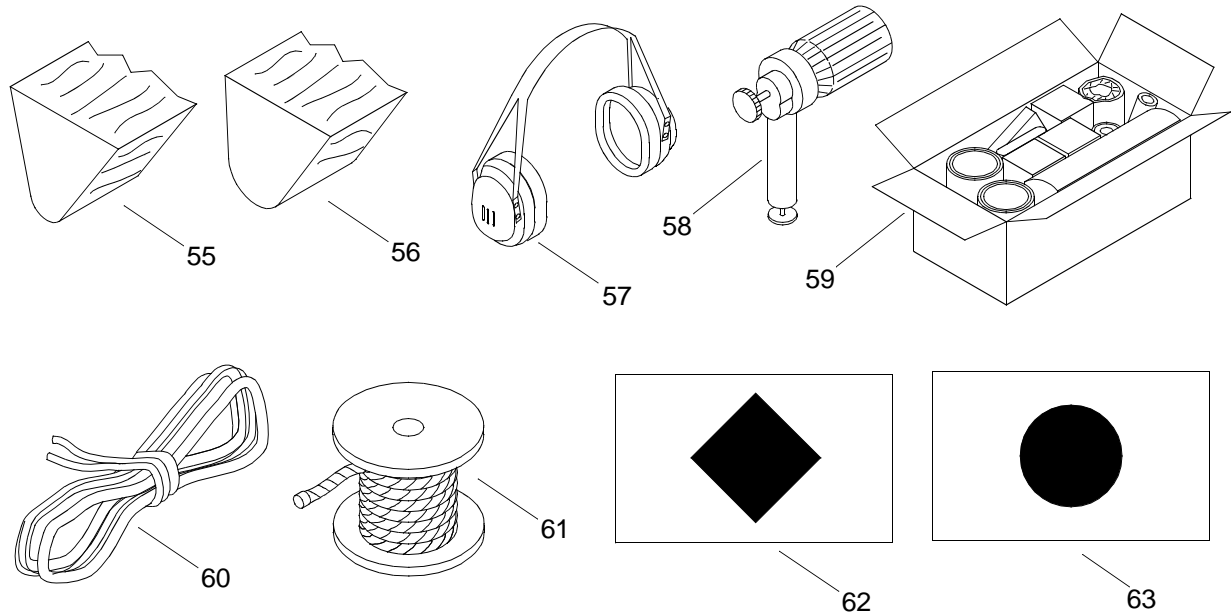


Table 1. Basic Issue Items. (BII) (Continued)

(1) ITEM NUMBER	(2) NATIONAL STOCK NUMBER	(3) DESCRIPTION, CAGEC AND PART NUMBER	(4) USABLE ON CODE	(5) U/M	(6) QTY RQD
46	4220-00-200-0538	LIFE PRESERVER, VEST (81349) MIL-L-18045		EA	8
47	6260-01-086-8077	LIGHT, CHEMILUMINESCENT (0BY83) 9-42740		EA	780
48		LOCKOUT TOOL BOX (1MZZ1) BRA 65289		KT	1
49		OIL REMOVAL SYSTEM (FLOCS) (6V008) Q4929112		KT	1
50	6515-00-137-6345	PLUG, EAR (89875) 4-375		BX	1
51	5510-00-260-8953	PLUG, WOOD (1 in. x 0 in. x 8 in.) (80064) 803-461043		EA	5
52	5510-00-260-8949	PLUG, WOOD (10 in. x 7 in. x 12 in.) (80064) S8800-461043		EA	5
53	5510-00-260-8958	PLUG, WOOD (2 in. x 0 in. x 4 in.) (80064) S8800-461043		EA	5
54	5510-00-260-8962	PLUG, WOOD (3 in. x 0 in. x 8 in.) (80064) 803-461043		EA	5



■ **Table 1. Basic Issue Items. (BII) (Continued)**

(1) ITEM NUMBER	(2) NATIONAL STOCK NUMBER	(3) DESCRIPTION, CAGEC AND PART NUMBER	(4) USABLE ON CODE	(5) U/M	(6) QTY RQD
55	5510-00-260-8969	PLUG, WOOD (7 in. x 3 in. x 10 in.) (80064) 803-461043		EA	5
56	5510-00-260-8973	PLUG, WOOD (8 in. x 4 in. x 10 in.) (80064) S8800-461043		EA	5
57	4240-00-022-2946	PROTECTOR, HEARING (58536) A-A-58084		EA	6
58	4930-01-119-4030	PUMP, SAMPLER (59578) 43-XV		EA	1
59	4730-00-542-3359	REPAIR (repair kit, emergency pipe) (81349) MILR17882		EA	1
60	4020-00-240-2161	ROPE, FIBROUS (81349) MIL-H-226		EA	1
61	4020-00-530-0698	ROPE, FIBROUS (81349) MIL-R-24049		RL	1
62	8345-01-101-1101	SHAPE, DAY, MARITIME (black diamond) (81349) MIL-S-29134		EA	1
63	8345-00-174-0453	SHAPE, DAY, MARITIME (black round) (81349) MIL-S-29108		EA	2

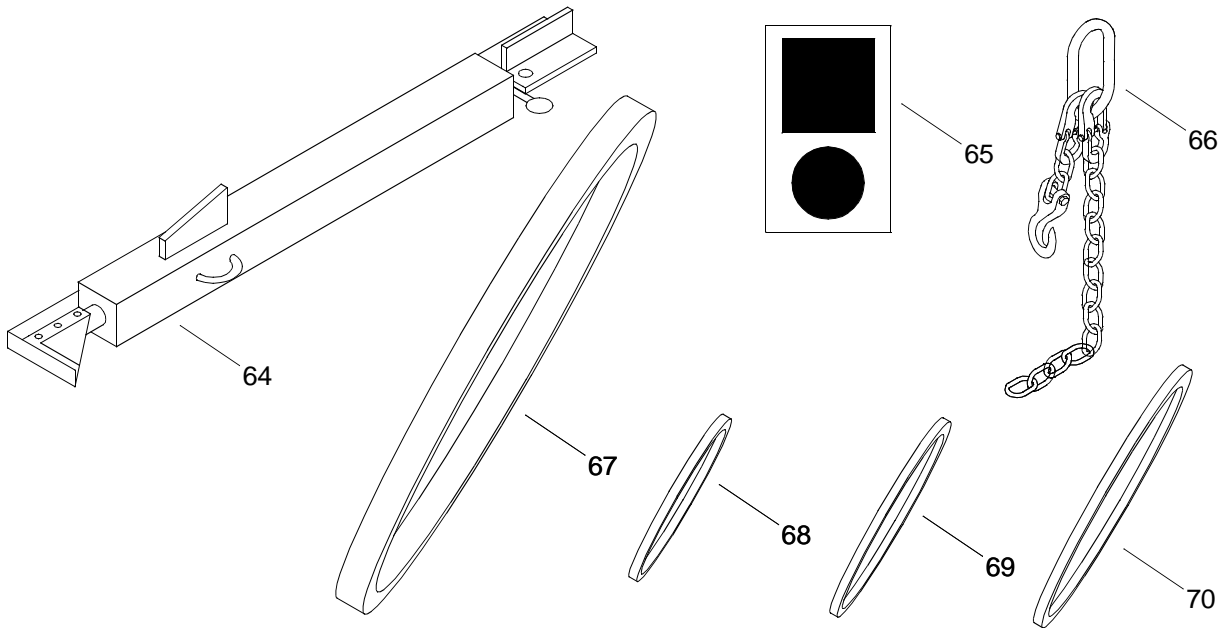


Table 1. Basic Issue Items. (BII) (Continued)

(1) ITEM NUMBER	(2) NATIONAL STOCK NUMBER	(3) DESCRIPTION, CAGEC AND PART NUMBER	(4) USABLE ON CODE	(5) U/M	(6) QTY RQD
64	2090-00-058-3737	SHORE, DAMAGE (81349) MIL-S-23965MODEL3-5		EA	4
65	1370-01-030-8330	SIGNAL, SMOKE AND ILLUMINATION (10001) DL3139734		EA	12
66	4010-01-477-8666	SLING, 36,000 lb ADJUSTABLE CHAIN Consisting Of: 1-1/4 in. Alloy Master Link (75535) 1014342 200 ft-5/8 in. Chain (75535) 273563 5/8 in. Clevis Grab Hook (75535) 1027695		EA	4
	2040-01-442-4055	5/8 in. Lokalloy (75535) 1014723			
67		SLING, LIFTING, 53,000 lb (brown) (3AJ34) EN600X25FT		EA	4
68		SLING, LIFTING, 5,300 lb (green) (3AJ34) EN60X4FT		EA	4
69		SLING, LIFTING, 5,300 lb (green) (3AJ34) EN60X5FT		EA	4
70		SLING, LIFTING, 5,300 lb (green) (3AJ34) EN60X6FT		EA	4

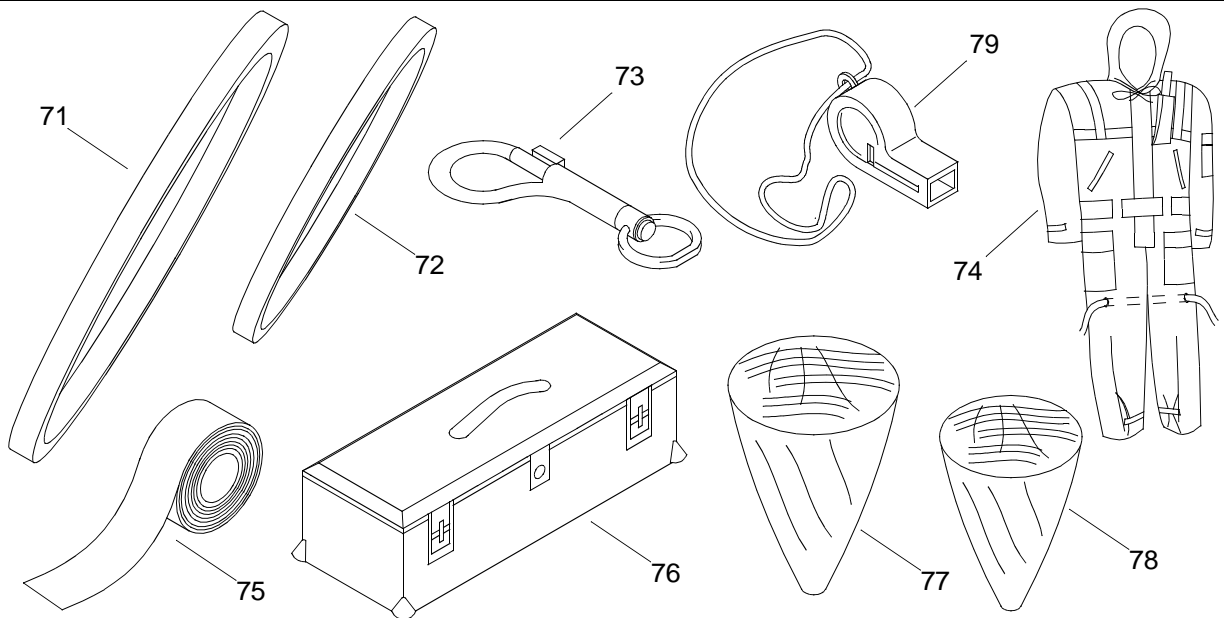


Table 1. Basic Issue Items. (BII) (Continued)

(1) ITEM NUMBER	(2) NATIONAL STOCK NUMBER	(3) DESCRIPTION, CAGEC AND PART NUMBER	(4) USABLE ON CODE	(5) U/M	(6) QTY RQD
71		SLING, LIFTING, 66,000 lb (olive) (3AJ34) EN800X30FT		EA	4
72		SLING, LIFTING, 8,400 lb (yellow) (3AJ34) EN90X20FT		EA	4
73	5340-00-275-4583	SNAP HOOK (81349) MIL-H-15021		BX	2
74	4220-01-251-6466	SUIT, SURVIVAL, COLD (63806) ISS-590		EA	8
75	9390-01-078-8660	TAPE, REFLECTIVE (63156) 3150-3X50YD		RL	1
76	5180-00-629-9783	TOOL KIT, GENERAL MECHANIC'S (rail and marine) (50980) SC 5180-90-CL-N55		EA	1
77	5510-00-268-3475	WEDGE, WOOD (1-1/2 in. x 2 in. x 12 in.) (80064) S8800-461043		EA	5
78	5510-00-268-3479	WEDGE, WOOD (2 in. X. 2 in. X. 8 in.) (80064) S8800-461043		EA	5
79	8465-00-254-8803	WHISTLE, BALL (58536) A-A-55106		EA	24

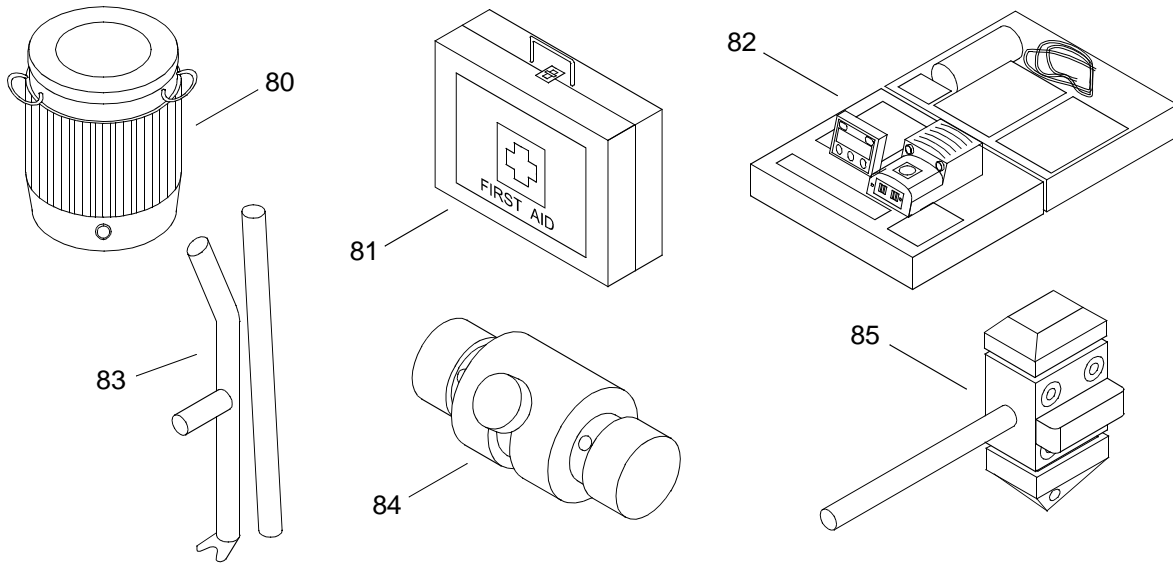


Table 1. Basic Issue Items. (BII) (Continued)

(1) ITEM NUMBER	(2) NATIONAL STOCK NUMBER	(3) DESCRIPTION, CAGEC AND PART NUMBER	(4) USABLE ON CODE	(5) U/M	(6) QTY RQD
80	7240-00-089-3827	CAN, WATER, MILITARY (81349) MIL-C-43613		EA	2
81	6545-00-116-1410	FIRST AID KIT, GENERAL PURPOSE (64616) 68-1371		EA	2
82		GAS-FREE METER (7J761) US ARMY-112160		EA	1
83		PIN RETRACTION TOOL (06101) MCS-99-673-001-132		EA	2
84		TWIST LOCKS, HORIZONTAL (059E5) BLR1212		EA	18
85		TWIST LOCKS, VERTICAL (94658) F633L-C		EA	64
86		PNEUMATIC TEST SET-UP (not illustrated) (51021) VK 192-1010-003		EA	1
87		TECHNICAL MANUAL, OPERATORS (not illustrated) TM 55-1945-205-10-1		EA	1

**OPERATOR MAINTENANCE
CAUSEWAY FERRY
EXPENDABLE AND DURABLE ITEMS LIST (EDIL)**

INTRODUCTION**Scope**

This work package lists expendable and durable items that you will need to operate and maintain the Roll-On/Roll-Off Discharge Facility. This list is for information only and is not authority to requisition the listed items. These items are authorized to you by CTA 50-970, Expendable/Durable Items (Except Medical, Class V Repair Parts, and Heraldic Items), or CTA 8-100, Army Medical Department Expendable/Durable Items.

Explanation of Columns in the Expendable/Durable Items List

Column (1) - Item Number. This number is assigned to the entry in the listing and is referenced in the narrative instructions to identify the item (e.g., Use antiseize compound. (Item 3, WP 0106 00)).

Column (2) - Level. This column identifies the lowest level of maintenance that requires the listed item. (C = Operator/Crew, O = Unit/AVUM, F = Direct Support/AVUM, H = General Support, D = Depot)

Column (3) - National Stock Number (NSN). This is the NSN assigned to the item which you can use to requisition it.

Column (4) - Item Name, Description, Commercial and Government Entity Code (CAGEC), and Part Number (PN). This column provides the other information you need to identify the item.

Column (5) - Unit of Measure (U/M). This code shows the physical measurement or count of an item, such as gallon, dozen, gross, etc.

EXPENDABLE AND DURABLE ITEMS LIST

■ **Table 1. Expendable and Durable Items List. (EDIL)**

(1) ITEM NUMBER	(2) LEVEL	(3) NATIONAL STOCK NUMBER	(4) ITEM NAME, DESCRIPTION, CAGEC AND PART NUMBER	(5) U/M
1	C	8040-01-250-3969	Adhesive, general purpose, medium strength, threadlocker (05972) 242	EA
2	C	6850-00-181-7933	Antifreeze, blue green with boiling point of 300°F (81349) MIL-A-46153	CN
3	C	8030-01-044-5034	Antiseize Compound, MIL-T-5544C, graphite and petroleum, one pound can for use on threaded fasteners and fittings (81348) MIL-T-5544	CN
4	C	6135-00-643-1310	Battery, Nonrechargeable, 6 volt battery (83740) EV90	PKG
5	C	6135-00-835-7210	Battery, Nonrechargeable, D size battery (90303) MN1300	PKG

Table 1. Expendable and Durable Items List. (EDIL) (Continued)

(1) ITEM NUMBER	(2) LEVEL	(3) NATIONAL STOCK NUMBER	(4) ITEM NAME, DESCRIPTION, CAGEC AND PART NUMBER	(5) U/M
6	O	6850-01-431-9025	Cleaner, Type II, 50 lb container (81349) MIL-C-29602	CO
7	C	9140-01-413-7511	Fuel, Diesel, summer grade DF2 low sulfur (81348) VV-F-800	GL
8	C	9150-00-145-0268	Grease, Aircraft, Grade 2, resistant to corrosion, water, low evaporation and oxidation (81349) MIL-G-81322	CN
9	C	9150-010197-7689	Grease, Automotive and Artillery, 6.5 lb can, conforms to PPP-C-96, Type V Class 2 (81399) MIL-10924-D	CN
10	C	9150-01-095-5512	Grease, Ball and Roller Bearing, lithium soap, temperature range -35° to 325°F (-54° to 163°C) (White Lithium Grease) (73219) L0189.001	CN
11	C	9150-00-929-7946	Grease, General Purpose, 14 oz cartridge, oxidation, corrosion, water, salt water, wear and extreme pressure resistant (76736) Dura-Lith Grease EP 2	CA
12	C	9150-00-235-5555	Grease, General Purpose, mineral oil and molybdenum disulfide, low evaporations, corrosive and salt water resistive (81349) MIL-G-23549	CN
13	C	9150-00-530-6814	Grease, Wire Rope - Exposed Gear, 35 lb can, petroleum oil based, corrosion and water resistant (81349) MIL-G-18458	CN
14	C	9150-00-189-6730	Lubricating Oil, Engine, 1 qt can, internal combustion engine, MIL-L-2104, 40 Grade (81349) MILL2104	QT
15	C	9150-00-186-6681	Lubricating Oil, Engine, 5 gallon can, internal combustion engine, MIL-L-2104, 30 Grade (81349) M2104-1-30W	QT
16	C	9150-01-035-5392	Lubricating Oil, Gear, 1 qt can, 80W90 Grade (81349) M2105-1-80W90	QT
17	C	9150-00-993-6621	Lubricating Oil, General Purpose, 55 gallon drum, conforms to PPP-D-729, Type 2 (19135) DTE-25	DR

■ **Table 1. Expendable and Durable Items List. (EDIL) (Continued)**

(1) ITEM NUMBER	(2) LEVEL	(3) NATIONAL STOCK NUMBER	(4) ITEM NAME, DESCRIPTION, CAGEC AND PART NUMBER	(5) U/M
18	C		Lubricating Oil, Mobilgear 626, 55 gallon drum, amber color, for use in all types of industrial enclosed gears (0AHK0) 610857-00	DR
19	C	7920-00-205-1711	Rag, Wiping, cotton, contains 50 lb, mixed colors (80244) 7920-00-205-1711	BE
20	C	6550-01-310-1677	Water, Reagent Distilled, four 1 gallon per package (07T46) C4350-1A	PG
21	C	5510-01-470-5122	Shoring Blockwood, 6 in. W X 30 in. L X 6 in. H, pressure treated pine (F6V7) 551-032-001	EA

**OPERATOR MAINTENANCE
CAUSEWAY FERRY
TOOL IDENTIFICATION LIST (TIL)**

INTRODUCTION

Scope

This work package lists all common tools and supplements and special tool/fixtures needed to maintain the CF.

Explanation of Columns in the Tool Identification List

Column (1) - Item Number. This number is assigned to the entry in the list and is referenced in the initial setup to identify the item (e.g., Respirator (Item 4, WP 0110 00)).

Column (2) - Item Name. This column lists the item by noun nomenclature and descriptive features (e.g. Gage, belt tension).

Column (3) - National Stock Number. This is the National Stock Number (NSN) assigned to the item; use it to requisition the item.

Column (4) - Part Number/CAGEC. Indicates the primary number used by the manufacturer (individual, company, firm, corporation, or Government activity) which controls design and characteristics of the item by means of its engineering drawings, specifications, standards, and inspection requirements to identify an item or range of items. The manufacturer's Commercial and Government Entity Code (CAGEC) is also included.

Column (5) - Reference. This column identifies the authorizing supply catalog or RPSTL for items listed in this work package.

TOOL IDENTIFICATION LIST

Table 1. Tool Identification List. (TIL)

(1) ITEM NO.	(2) ITEM NAME	(3) NATIONAL STOCK NUMBER	(4) PART NUMBER/ CAGEC	(5) REFERENCE
1	Lubricating gun, hand	4930-00-965-0288	30415 (77335)	
2	Mop, wet	7920-00-224-8726	7920-00-224-8726 (83421)	
3	Oiler, hand	4930-00-274-5713	A-A-50477B (58536)	SC 4910-95-A72
4	Respirator, air filtering	4240-01-088-8546	14130047 (79687)	SC 4910-95-A68
5	Screwdriver, Flat Tip, Magnetic	5120-00-227-7377	B107.15 TY1 CL1/ CL2DED (80204)	SC 4910-95-A68

INDEX

Subject **WP Sequence No. – Page No.**

A

Alphabetical IndexINDEX-1

Above Deck Equipment

Preparation For Movement 0041 00 001

Preparation For Use 0014 00 001

Anchor Deployment and Recovery, Operating Procedures 0034 00 001

Anchorboard Assembly

Preparation For Movement 0040 00 001

Preparation For Use 0015 00 001

Assembly of Causeway Ferry on Deck of Sealift Vessel, Preparation For Use 0013 00 001

Assembly of Causeway Ferry in Water, Preparation For Use 0013 10 001

B

Basic Issue Items (BII)

Equipment, Stowage 0060 00 001

List 0105 00 001

Battery Selector Switch, Operating Procedures 0034 10 001

Beach End Section

Preparation For Movement 0044 00 001

Preparation For Use 0012 00 001

Bilge Pump(s) Will Not Function, Troubleshooting Procedures 0083 00 001

Bow Stub Mast

Preparation For Movement 0038 10 001

Preparation For Use 0016 10 001

C

Causeway Ferry

Operating Procedures 0020 00 001

Preparation For Movement 0043 00 001

Preparation For Use 0019 00 001

Stabilizers, Preparation For Movement..... 0041 10 001

Stabilizers, Preparation For Use..... 0013 20 001

Components of End Item (COEI) List 0104 00 001

Crew Shelter

Preparation For Movement..... 0035 20 001

Preparation For Use..... 0019 20 001

D

DC To DC Converter, Operating Procedures 0033 00 001

Decals and Instruction Plates Location 0035 00 001

Deck Box

Preparation For Movement 0035 10 001

Preparation For Use 0019 10 001

Description and Data

Equipment Characteristics, Capabilities and Features 0002 00 001

Equipment Data 0004 00 001

Location and Description of Major Components 0003 00 001

INDEX (CONT'D)

Subject

WP Sequence No.– Page No.

D (CONT'D)

Description and Data, Equipment Data 0004 00 001

Diesel Engine

 Ammeter Indicates Discharging of System, Troubleshooting Procedures 0082 00 001

 Audible Alarm and Warning Light On (Normal Operation),
 Troubleshooting Procedures 0069 00 001

 Emergency Procedure 0051 00 001

 Fails to Start, Starts With Difficulty and Runs Badly,
 Troubleshooting Procedures 0065 00 001

 Oil Pressure Gauge Reads Above 70 PSI (Normal Operation),
 Troubleshooting Procedures 0070 00 001

 Overheating (Audible Alarm and Warning Light On),
 Troubleshooting Procedures 0071 00 001

 Starts With Difficulty and Runs Rough, Troubleshooting Procedures 0067 00 001

 Sudden Loss of Power (Heavy Black Smoke), Troubleshooting Procedures 0063 00 001

 Sudden Loss of Power (No Black Smoke), Troubleshooting Procedures 0068 00 001

 Will Not Turn Over, Troubleshooting Procedures 0066 00 001

 Will Turn Over, But Will Not Start, Troubleshooting Procedures 0064 00 001

D-Ring/Cloverleaf and Deck Cleat Fittings

 Preparation For Movement 0038 00 001

 Preparation For Use 0009 00 001

Drive Train Does Not Operate Freely and Smoothly, Excessive Vibration Is Experienced
 During Operation, Troubleshooting Procedures 0072 00 001

E

Emergency Starting Procedures, Emergency Procedures 0050 10 001

Emergency Starting Procedures, Slaving the Causeway Ferry, Emergency Procedure 0050 20 001

Environment/Weather, Unusual 0050 00 001

Equipment Characteristics, Capabilities and Features, Description and Data 0002 00 001

Exhaust Plenum Ventilation Fan Will Not Operate, Troubleshooting Procedures 0062 00 001

Expendable and Durable Items List (EDIL) 0106 00 001

F

Fenders

 Preparation For Movement 0037 00 001

 Preparation For Use 0017 00 001

Fire Suppression System, Manually Operate, Emergency Procedure 0052 00 001

Flexor Connectors, Preparation For Movement (Deleted) 0048 00 001

G

General Information 0001 00 001

H

Hazardous Material Warning Iconsc

How To Use This Manual v

Hydraulic System Has No Pressure, Troubleshooting Procedures 0075 00 001

INDEX (CONT'D)

<u>Subject</u>	<u>WP Sequence No. – Page No.</u>
I	
Interface and Switchbox, Operating Procedures	0022 00 001
Intermediate Section	
Preparation For Movement	0045 00 001
Preparation For Use	0011 00 001
L	
List of Effective Pages/Work Packages	A
Location and Description of Major Components, Description and Data	0003 00 001
M	
Main Mast	
Deck Floodlight, Preparation For Use	0016 20 001
Deck Floodlights, Preparation For Movement	0040 10 001
Main Mast Deck, Floodlight(s) Will Not Function, Troubleshooting Procedures	0098 20 001
Maintenance Allocation Chart (MAC)	0103 00 001
Maintenance Allocation Chart (MAC), Introduction	0102 00 001
Male and Female Guillotine Connectors	
Preparation For Movement	0047 00 001
Preparation For Use	0008 00 001
Marine Gear Clutch	
Status Light, Not Operational, Troubleshooting Procedures	0074 00 001
Will Not Engage In Engage/Backflush Directions, Troubleshooting Procedures ..	0073 00 001
Module ISOPAK	
Preparation For Movement	0049 00 001
Preparation For Use	0007 00 001
Module Strings	
Preparation For Movement	0046 00 001
Preparation For Use	0010 00 001
N	
Navigation Lights	
Audible Pulse Beeper Sounds, Troubleshooting Procedures	0097 00 001
Will Not Function, Troubleshooting Procedures	0098 00 001
Nuclear, Biological or Chemical Decontamination	0049 10 001
O	
Operating Procedures, Causeway Ferry	0020 00 001
Operator Controls and Indicators, Description and Use	0006 00 001

INDEX (CONT'D)

Subject

WP Sequence No. – Page No.

O (CONT'D)

Operators Cab

Accessories Do Not Function, Troubleshooting Procedures	0085 00 001
All Circuits Controlled By 3A3CB1-3A3CB10 Are Not Functioning, Troubleshooting Procedures	0085 30 001
Chart (Map) Light, Operating Procedures	0034 20 001
Defroster Fan Does Not Operate (No Fan and No Heat), Troubleshooting Procedures	0085 10 001
Heater Does Not Operate, Troubleshooting Procedures	0085 20 001
No Power To Control Panels, Troubleshooting Procedures	0084 00 001

P

Pilothouse (Operators Cab), Stowage.....	0060 20 001
Powered Section	
Disassembly On Deck, Preparation For Movement	0042 00 001
Disassembly In Water, Preparation For Movement	0042 10 001
Precision Lightweight Global Positioning Receiver (PLGR)	
Cleared Memory, Troubleshooting Procedures	0096 00 001
Does Not Display a Valid Position, Troubleshooting Procedures	0095 00 001
Mark Position of Man Overboard, Emergency Procedure	0055 00 001
No Power, Troubleshooting Procedures	0094 00 001
Perform Crypto Variable Operations, Operating Procedures	0032 00 001
Perform Initial Setup, Operating Procedures	0029 00 001
Setup Route Navigation, Operating Procedures	0031 00 001
Setup Waypoints, Operating Procedures	0030 00 001
Preparation For Movement, Causeway Ferry	0043 00 001
Preventive Maintenance Checks and Services (PMCS)	
Lubrication Procedures	0100 00 001
Procedures Introduction	0099 00 001
Public Address Set (Loudhailer)	
Emergency Procedure	0059 00 001
No Power, Troubleshooting Procedures	0086 00 001
Operating Procedures	0023 00 001
Will Not Transmit Fog Signal To (Loudhailer External Speaker), Troubleshooting Procedures	0088 00 001
Will Not Transmit VHF/FM DSC Transceiver Audio To Hailer Horn (Loudhailer External Speaker), Troubleshooting Procedures	0089 00 001
Will Not Transmit Voice To Hailer Horn (Loudhailer External Speaker), Troubleshooting Procedures	0087 00 001
Pump-Jet	
Develop Small Amount of Thrust (Not Enough Water Being Delivered), Troubleshooting Procedures	0077 00 001
No Propulsion, Troubleshooting Procedures	0076 00 001
No Steering Control Indication, Troubleshooting Procedures	0081 00 001
No Steering Control, Troubleshooting Procedures	0078 00 001
Steering Reacts Sluggishly, Troubleshooting Procedures	0079 00 001

INDEX (CONT'D)

<u>Subject</u>	<u>WP Sequence No. – Page No.</u>
R	
References	0101 00 001
S	
Safety Equipment	
Preparation For Movement	0036 00 001
Preparation For Use	0018 00 001
Safety Warning Icons	b
Side Fenders, Stowage	0060 10 001
SINCGARS Radio, Operating Procedures	0024 00 001
Steering System	
Emergency Engagement of Marine Gear, Emergency Procedure	0054 00 001
Emergency Steering, Emergency Procedure	0053 00 001
Steering System, No Steering From Operators Cab, Troubleshooting Procedures	0080 00 001
Stowage, Anchorboard and Ship Fendering	0060 30 001
Stub Navigation Mast	
Preparation For Movement	0039 00 001
Preparation For Use	0016 00 001
T	
Theory of Operation	0005 00 001
Tool Identification List (TIL)	0107 00 001
Troubleshooting Procedures	
Bilge Pump(s) Will Not Function	0083 00 001
Bow Light Will Not Function	0098 10 001
Diesel Engine	
Ammeter Indicates Discharging of System	0082 00 001
Fails to Start, Starts With Difficulty and Runs Badly	0065 00 001
Oil Pressure Gauge Reads Above 70 PSI (Normal Operation)	0070 00 001
Overheating (Audible Alarm and Warning Light On)	0071 00 001
Starts With Difficulty and Runs Rough	0067 00 001
Sudden Loss of Power (Heavy Black Smoke)	0063 00 001
Sudden Loss Of Power (No Black Smoke)	0068 00 001
Will Not Turn Over	0066 00 001
Will Turn Over, But Will Not Start	0064 00 001
Diesel Engine Audible Alarm and Warning Light On (Normal Operation)	0069 00 001
Drive Train Does Not Operate Freely and Smoothly, Excessive Vibration Is	
Experienced During Operation	0072 00 001
Exhaust Plenum Ventilation Fan Will Not Operate	0062 00 001
Hydraulic System Has No Pressure	0075 00 001
Index	0061 00 001
Main Mast Deck Floodlight(s) Will Not Function	0098 20 001
Marine Gear Clutch	
Status Light, Not Operational	0074 00 001
Will Not Engage In Engage/Backflush Directions	0073 00 001

INDEX (CONT'D)

Subject

WP Sequence No. – Page No.

T (CONT'D)

Troubleshooting Procedures (Continued)

- Navigation Lights
 - Audible Pulse Beeper Sounds 0097 00 001
 - Will Not Function 0098 00 001
- Operators Cab
 - Accessories Do Not Function 0085 00 001
 - All Circuits Controlled By 3A3CB1-3A3CB10
 - Are Not Functioning 0085 30 001
 - Defroster Fan Does Not Operate 0085 10 001
 - Heater Does Not Operate 0085 20 001
 - No Power To Control Panels 0084 00 001
- Precision Lightweight Global Positioning Receiver (PLGR)
 - Cleared Memory 0096 00 001
 - Does Not Display a Valid Position 0095 00 001
 - No Power 0094 00 001
- Public Address Set (Loudhailer)
 - No Power 0086 00 001
 - Will Not Transmit Fog Signal To Hailer Horn (Loudhailer External Speaker) 0088 00 001
 - Will Not Transmit VHF/FM DSC Transceiver Audio To Hailer Horn
(Loudhailer External Speaker) 0089 00 001
 - Will Not Transmit Voice To Hailer Horn (Loudhailer External Speaker) 0087 00 001
- Pump-Jet
 - Develop Small Amount of Thrust (Not Enough Water Being Delivered) 0077 00 001
 - No Propulsion 0076 00 001
 - No Steering Control 0078 00 001
 - No Steering Control Indication 0081 00 001
 - Steering Reacts Sluggishly 0079 00 001
- Steering System, No Steering From Operators Cab 0080 00 001
- VHF/FM DSC Transceiver
 - Does Not Display a Valid Position 0093 00 001
 - No Power 0090 00 001
 - Will Not Receive 0091 00 001
 - Will Not Transmit 0092 00 001

V

VHF/FM DSC Transceiver

- Cancel Distress, Emergency Procedure 0058 00 001
- Does Not Display a Valid Position, Troubleshooting Procedures 0093 00 001
- DSC Functions, Operating Procedures 0028 00 001
- No Power, Troubleshooting Procedures 0090 00 001
- Operating Procedures 0026 00 001
- Perform Initial Setup, Operating Procedures 0025 00 001
- Perform User Setups, Operating Procedures 0027 00 001
- Receiving a Distress, Emergency Procedure 0057 00 001
- Send Distress, Emergency Procedure 0056 00 001
- Will Not Receive, Troubleshooting Procedures 0091 00 001
- Will Not Transmit, Troubleshooting Procedures 0092 00 001

INDEX (CONT'D)

Subject

WP Sequence No. – Page No.

V (CONT'D)

VHF/FM Handheld Transceiver, Operating Procedures 0021 00 001

W

Warning Summarya

These are the instructions for sending an electronic 2028.

The following format must be used if submitting an electronic 2028. The subject line must be exactly the same and all fields must be included; however, only the following fields are mandatory: 1, 3, 4, 5, 6, 7, 8, 9, 10, 13, 15, 16, 17 and 27.

From: "Whoever" whoever@avma27.army.mil
To: whoever@avma27.army.mil
To: TACOM-TECH-PUBS@ria.army.mil

Subject:DA Form 2028

1. **From:** Joe Smith
2. **Unit:** home
3. **Address:** 4300 Park
4. **City:** Hometown
5. **St:** MO
6. **Zip:** 77777
7. **Date Sent:** 19-OCT-93
8. **Pub no:** 55-1915-200-10
9. **Pub Title:** TM
10. **Publication Date:** 11-APR-88
11. **Change Number:** 12
12. **Submitter Rank:** MSG
13. **Submitter Fname:** Joe
14. **Submitter Mname:** T
15. **Submitter Lname:** Smith
16. **Submitter Phone:** 123-123-1234
17. **Problem:** 1
18. **Page:** 1
19. **Paragraph:** 3
20. **Line:** 4
21. **NSN:** 5
22. **Reference:** 6
23. **Figure:** 7
24. **Table:** 8
25. **Item:** 9
26. **Total:** 123
27. **Text:**

This is the text for the problem below line 27.

RECOMMENDED CHANGES TO PUBLICATIONS AND BLANK FORMS <small>For use of this form, see AF 25-32; the proponent agency is DAASA</small>						Use Part II (reverse) for Repair Parts and Special Tool Lists (RPSTL) and Supply Catalogs/Supply Manuals (SC/SM).	DATE
TO: <i>(Forward to proponent of publication or form) (Include ZIP Code)</i>						FROM: <i>(Activity and location) (Include ZIP Code)</i>	
PART I - ALL PUBLICATIONS (EXCEPT RPSTL AND SC/SM) AND BLANK FORMS							
PUBLICATION/FORM NUMBER						DATE	TITLE
ITEM	PAGE	PARA-GRAPH	LINE	FIGURE NO.	TABLE	RECOMMENDED CHANGES AND REASON	
<small>* Reference to line numbers within the paragraph or subparagraph.</small>							
TYPED NAME, GRADE OR TITLE						TELEPHONE EXCHANGE/AUTOVON, PLUS EXTENSION	SIGNATURE

TO: <i>(Forward direct to addressee listed in publication)</i>			FROM: <i>(Activity and location) (Include ZIP Code)</i>				DATE	
PART II - REPAIR PARTS AND SPECIAL TOOL LISTS AND SUPPLY CATALOGS/SUPPLY MANUALS								
PUBLICATION NUMBER				DATE			TITLE	
PAGE NO.	COLM NO.	LINE NO.	NATIONAL STOCK NUMBER	REFERENCE NO.	FIGURE NO.	ITEM NO.	TOTAL NO. OF MAJOR ITEMS SUPPORTED	RECOMMENDED ACTION
PART III - REMARKS <i>(Any general remarks or recommendations, or suggestions for improvement of publications and blank forms. Additional blank sheets may be used if more space is needed.)</i>								
TYPED NAME, GRADE OR TITLE				TELEPHONE EXCHANGE/AUTOVON. PLUS EXTENSION			SIGNATURE	

By Order of the Secretary of the Army:

PETER J. SCHOOMAKER
General, United States Army
Chief of Staff

Official:



JOEL B. HUDSON

Administrative Assistant to the
Secretary of the Army

0225901

To be distributed in accordance with the initial distribution number (IDN) 256754 requirements for TM 55-1945-205-10-1.

The Metric System and Equivalents

Linear Measure

1 centimeter = 10 millimeters = .39 inch
 1 decimeter = 10 centimeters = 3.94 inches
 1 meter = 10 decimeters = 39.37 inches
 1 dekameter = 10 meters = 32.8 feet
 1 hectometer = 10 dekameters = 328.08 feet
 1 kilometer = 10 hectometers = 3,280.8 feet

Weight

1 centigram = 10 milligrams = .15 grain
 1 decigram = 10 centigrams = 1.54 grains
 1 gram = 10 decigrams = .035 ounce
 1 dekagram = 10 grams = .35 ounce
 1 hectogram = 10 dekagrams = 3.52 ounces
 1 kilogram = 10 hectograms = 2.2 pounds
 1 quintal = 100 kilograms = 220.46 pounds
 1 metric ton = 10 quintals = 1.1 short tons

Liquid Measure

1 centiliter = 10 milliliters = .34 fl. ounce
 1 deciliter = 10 centiliters = 3.38 fl. ounces
 1 liter = 10 deciliters = 33.81 fl. ounces
 1 dekaliter = 10 liters = 2.64 gallons
 1 hectoliter = 10 dekaliters = 26.42 gallons
 1 kiloliter = 10 hectoliters = 264.18 gallons

Square Measure

1 sq. centimeter = 100 sq. millimeters = .155 sq. inch
 1 sq. decimeter = 100 sq. centimeters = 15.5 sq. inches
 1 sq. meter (centare) = 100 sq. decimeters = 10.76 sq. feet
 1 sq. dekameter (are) = 100 sq. meters = 1,076.4 sq. feet
 1 sq. hectometer (hectare) = 100 sq. dekameters = 2.47 acres
 1 sq. kilometer = 100 sq. hectometers = .386 sq. mile

Cubic Measure

1 cu. centimeter = 1000 cu. millimeters = .06 cu. inch
 1 cu. decimeter = 1000 cu. centimeters = 61.02 cu. inches
 1 cu. meter = 1000 cu. decimeters = 35.31 cu. feet

Approximate Conversion Factors

To change	To	Multiply by	To change	To	Multiply by
inches	centimeters	2.540	ounce-inches	newton-meters	.007062
feet	meters	.305	centimeters	inches	.394
yards	meters	.914	meters	feet	3.280
miles	kilometers	1.609	meters	yards	1.094
square inches	square centimeters	6.451	kilometers	miles	.621
square feet	square meters	.093	square centimeters	square inches	.155
square yards	square meters	.836	square meters	square feet	10.764
square miles	square kilometers	2.590	square meters	square yards	1.196
acres	square hectometers	.406	square kilometers	square miles	.386
cubic feet	cubic meters	.028	square hectometers	acres	2.471
cubic yards	cubic meters	.766	cubic meters	cubic feet	35.315
fluid ounces	milliliters	29.573	cubic meters	cubic yards	1.308
pints	liters	.473	milliliters	fluid ounces	.034
quarts	liters	.946	liters	pints	2.113
gallons	liters	3.785	liters	quarts	1.057
ounces	grams	28.349	liters	gallons	.264
pounds	kilograms	.454	grams	ounces	.035
short tons	metric tons	.907	kilograms	pounds	2.205
pound-feet	newton-meters	1.356	metric tons	short tons	1.102
pound-inches	newton-meters	11.296			

Temperature (Exact)

°F Fahrenheit temperature $\frac{5}{9}$ (after subtracting 32)

Celsius temperature °C

